

GROUP 1 HYDRAULIC CIRCUIT

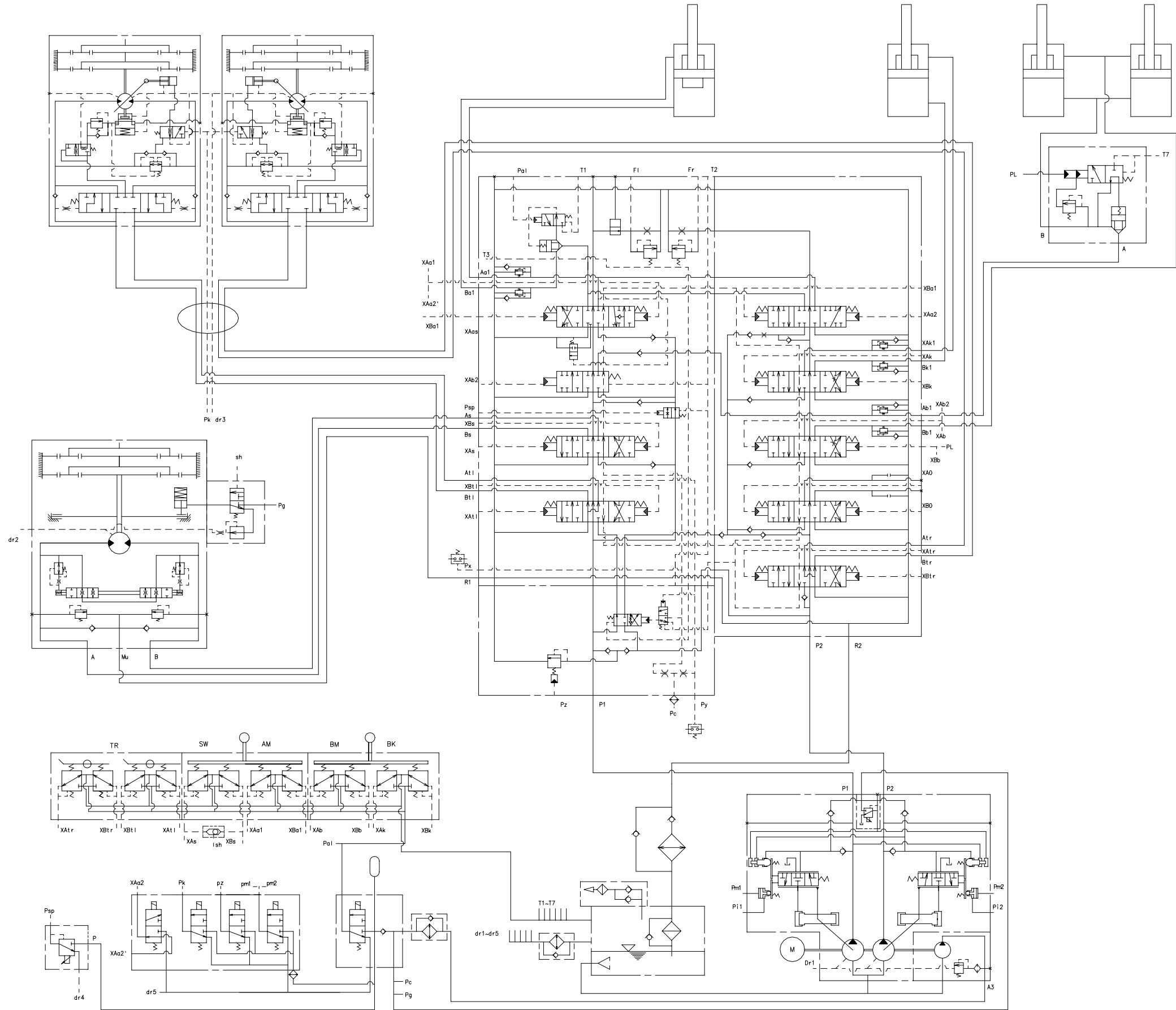

- 1 Main pump
- 2 Main control valve
- 3 Swing motor
- 4 Travel motor
- 5 RCV lever
- 6 RCV pedal
- 7 Boom cylinder(RH)
- 8 Boom cylinder(LH)
- 9 Arm cylinder
- 10 Bucket cylinder
- 11 Turning joint
- 12 Check valve
- 13 Check valve
- 14 Hydraulic tank
- 15 Oil cooler
- 16 Air breather
- 17 Bypass valve
- 18 Strainer assembly
- 19 Spin filter
- 20 Shuttle valve
- 21 Boom holding valve
- 22 Safety solenoid valve
- 23 Solenoid valve(4 cartridge)
- 24 Swing EPPR valve
- 25 Line filter
- 26 Pressure switch
- 27 Accumulator
- 28 Last guard filter
- 29 Last guard filter