

## GROUP 12 EPPR(Electro Proportional Pressure Reducing) VALVE

### 1. COMPOSITION OF EPPR VALVE

EPPR valve consist of electro magnet and spool valve installed at main hydraulic pump.

#### 1) ELECTRO MAGNET VALVE

Receive electric current from CPU controller and move the spool proportionally depend on the specific amount of electric current value.

#### 2) SPOOL VALVE

Is the two way direction control valve for pilot pressure to reducing hydraulic pump flow.

When electro magnet valve activate, pilot pressure enter to flow regulator at hydraulic pump.

So, pump flow decrease to prevent engine stall.

#### 3) PRESSURE AND ELECTRIC CURRENT VALUE FOR EACH MODE

Mode	Pressure		Electric current (mA)	Engine rpm
	kg/cm <sup>2</sup>	psi		
H	5 ± 3	70 ± 40	(240 ± 30)	2250 + 50
S	10 ± 3	140 ± 40	(320 ± 30)	2250 + 50
L	17 ± 3	240 ± 40	(420 ± 30)	2050 + 50
F	21 ± 3	300 ± 40	(470 ± 30)	1850 + 50
★	16 ± 3	230 ± 40	(390 ± 30)	-

★ Manually operated condition when prolix switch is selected emergency position.

## 2. OPERATING PRINCIPLE

### 1) STRUCTURE

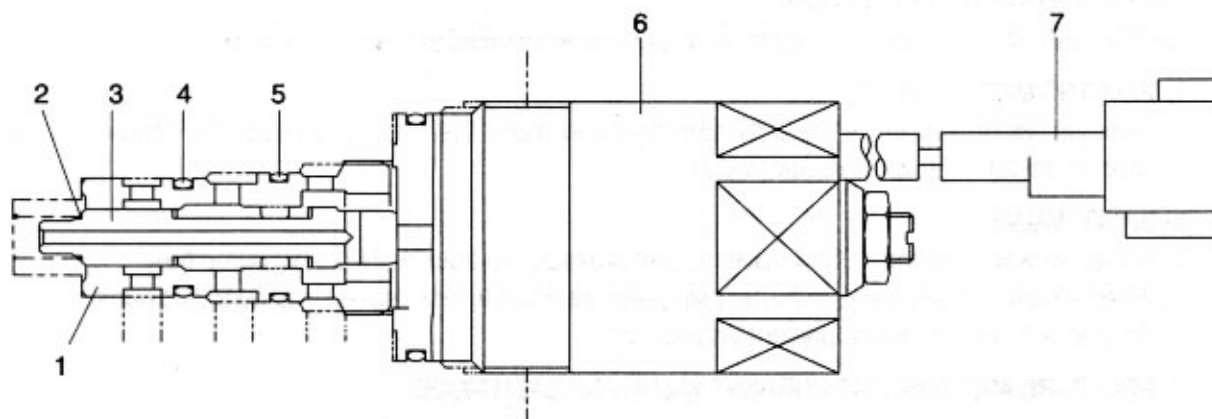

- 1 Sleeve
- 2 Spring
- 3 Spool
- 4 O-ring
- 5 O-ring
- 6 Solenoid valve
- 7 Connector

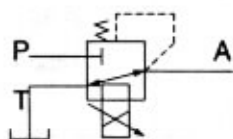

- P Pilot oil supply line(Pilot pressure)
- T Return to tank
- A Secondary pressure to flow regulator at hydraulic pump.

### 2) AT H MODE

Pressure line blocked so, A oil return to tank.

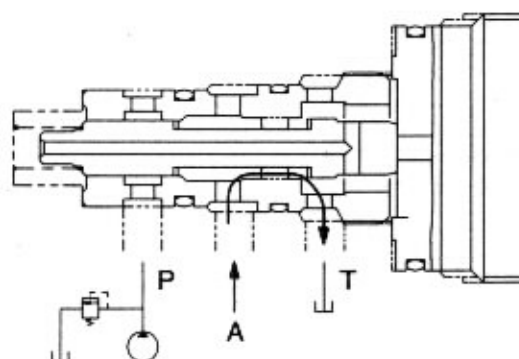
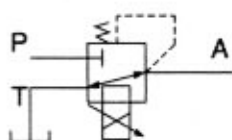

### 3) AT S, L, F MODE

Secondary pressure enter to A.

