

SECTION 3 HYDRAULIC SYSTEM

Group 1 Hydraulic Circuit	3-1
Group 2 Main Circuit	3-2
Group 3 Pilot Circuit	3-5
Group 4 Single Operation	3-13
Group 5 Combined Operation	3-23

GROUP 1 HYDRAULIC CIRCUIT

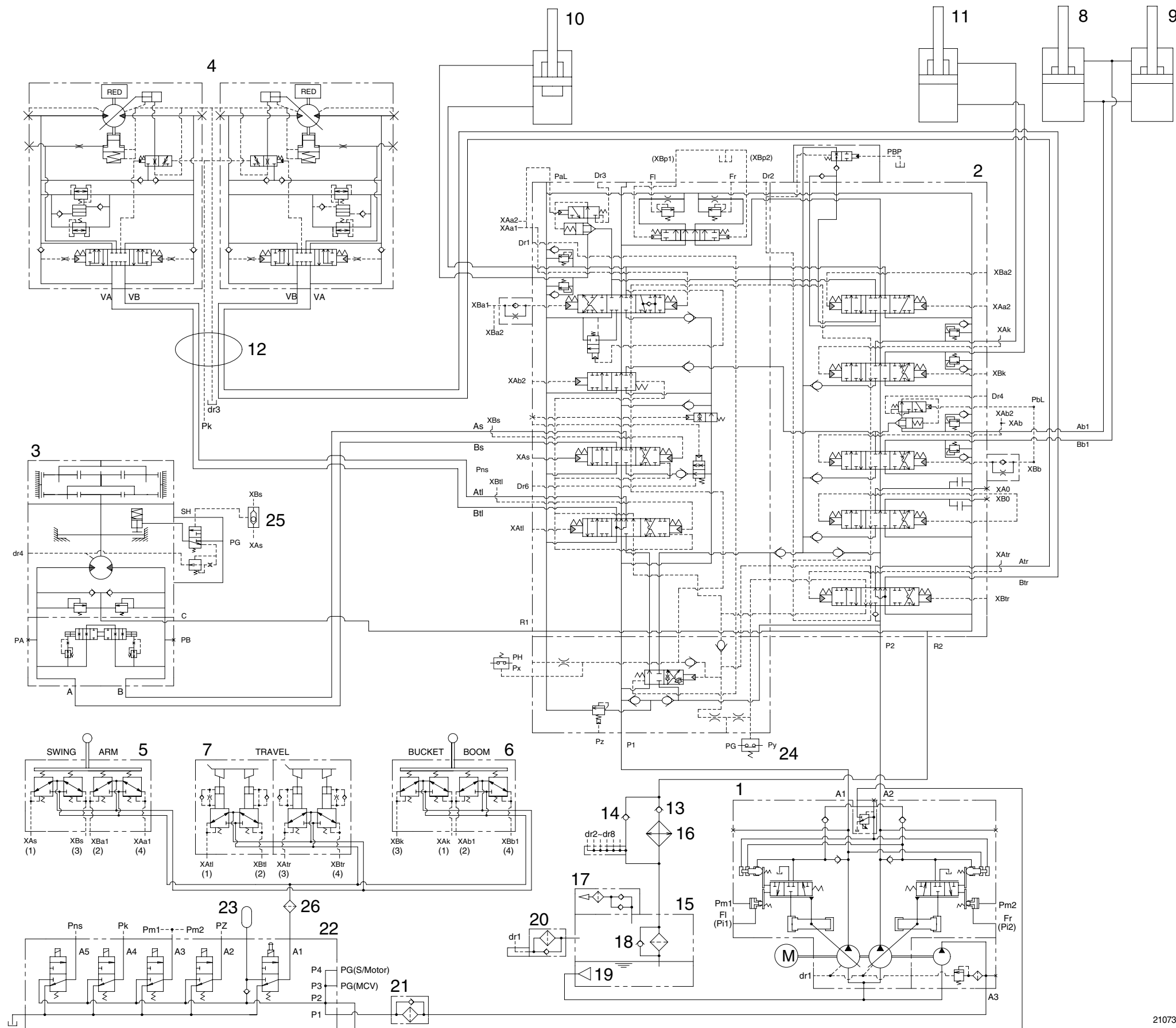

- 1 Main pump
- 2 Main control valve
- 3 Swing motor
- 4 Travel motor
- 5 RCV lever(LH)
- 6 RCV lever(RH)
- 7 RCV pedal
- 8 Boom cylinder(LH)
- 9 Boom cylinder(RH)
- 10 Arm cylinder
- 11 Bucket cylinder
- 12 Turning joint
- 13 Check valve
- 14 Check valve
- 15 Hydraulic tank
- 16 Oil cooler
- 17 Air breather
- 18 Bypass valve
- 19 Strainer
- 20 Spin filter
- 21 Line filter
- 22 Solenoid valve
- 23 Accumulator
- 24 Pressure switch
- 25 Shuttle valve
- 26 Last guard filter

21073HS01

HYDRAULIC CIRCUIT(#1135 and up, yellow color)

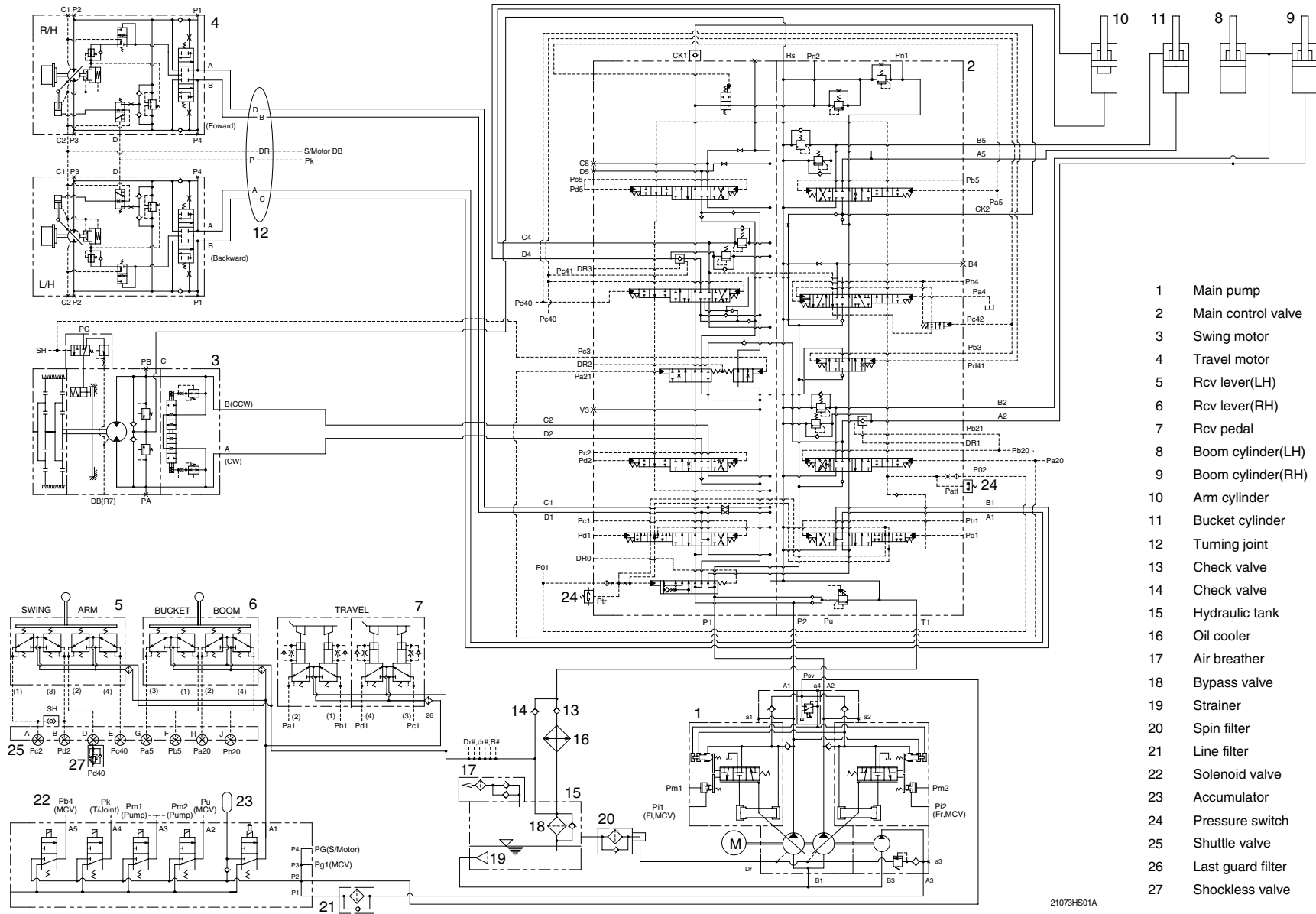

- 1 Main pump
- 2 Main control valve
- 3 Swing motor
- 4 Travel motor
- 5 Rcv lever(LH)
- 6 Rcv lever(RH)
- 7 Rcv pedal
- 8 Boom cylinder(LH)
- 9 Boom cylinder(RH)
- 10 Arm cylinder
- 11 Bucket cylinder
- 12 Turning joint
- 13 Check valve
- 14 Check valve
- 15 Hydraulic tank
- 16 Oil cooler
- 17 Air breather
- 18 Bypass valve
- 19 Strainer
- 20 Spin filter
- 21 Line filter
- 22 Solenoid valve
- 23 Accumulator
- 24 Pressure switch
- 25 Shuttle valve
- 26 Last guard filter
- 27 Shockless valve

21073HS01A