

## GROUP 6 TRAVEL DEVICE

### 1. REMOVAL AND INSTALL

#### 1) REMOVAL

- (1) Swing the work equipment 90° and lower it completely to the ground.
- (2) Operate the control levers and pedals several times to release the remaining pressure in the hydraulic piping.
- (3) Loosen the breather slowly to release the pressure inside the hydraulic tank.

**▲ Escaping fluid under pressure can penetrate the skin causing serious injury.**

※ When pipes and hoses are disconnected, the oil inside the piping will flow out, so catch it in oil pan.

- (4) Remove the track shoe assembly.  
For details, see **removal of track shoe assembly**.
- (5) Remove the cover.
- (6) Remove the hose.  
※ Fit blind plugs to the disconnected hoses.
- (7) Remove the bolts and the sprocket.
- (8) Sling travel device assembly (1).
- (9) Remove the mounting bolts (2), then remove the travel device assembly.  
· Weight : 305kg (670lb)

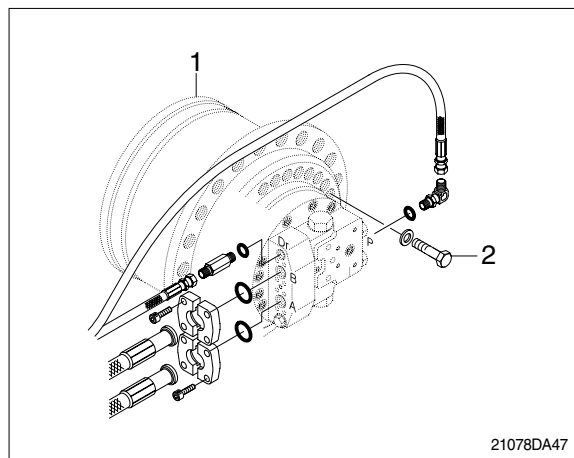

#### 2) INSTALL

- (1) Carry out installation in the reverse order to removal.
- (2) Bleed the air from the travel motor.
  - ① Remove the air vent plug.
  - ② Pour in hydraulic oil until it overflows from the port.
  - ③ Tighten plug lightly.
  - ④ Start the engine, run at low idling, and check oil come out from plug.
  - ⑤ Tighten plug fully.
- (3) Confirm the hydraulic oil level and check the hydraulic oil leak or not.

## 2. STRUCTURE

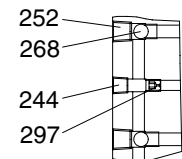
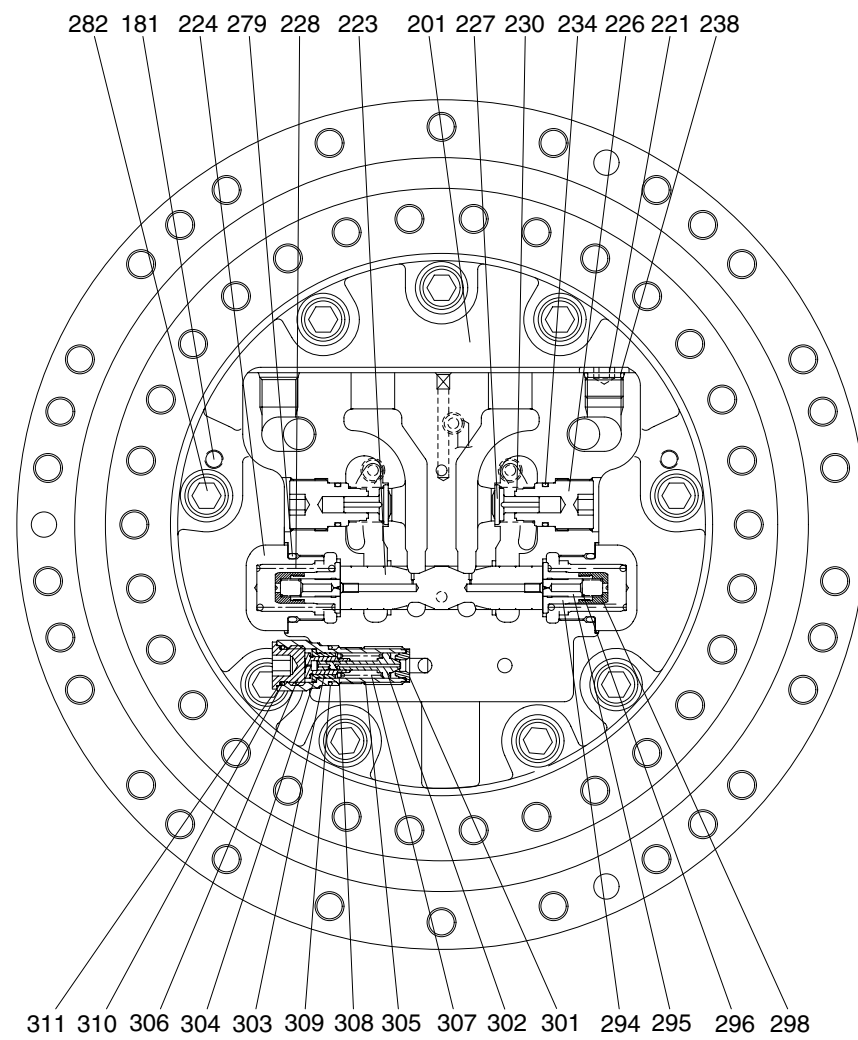

SECTION A-A

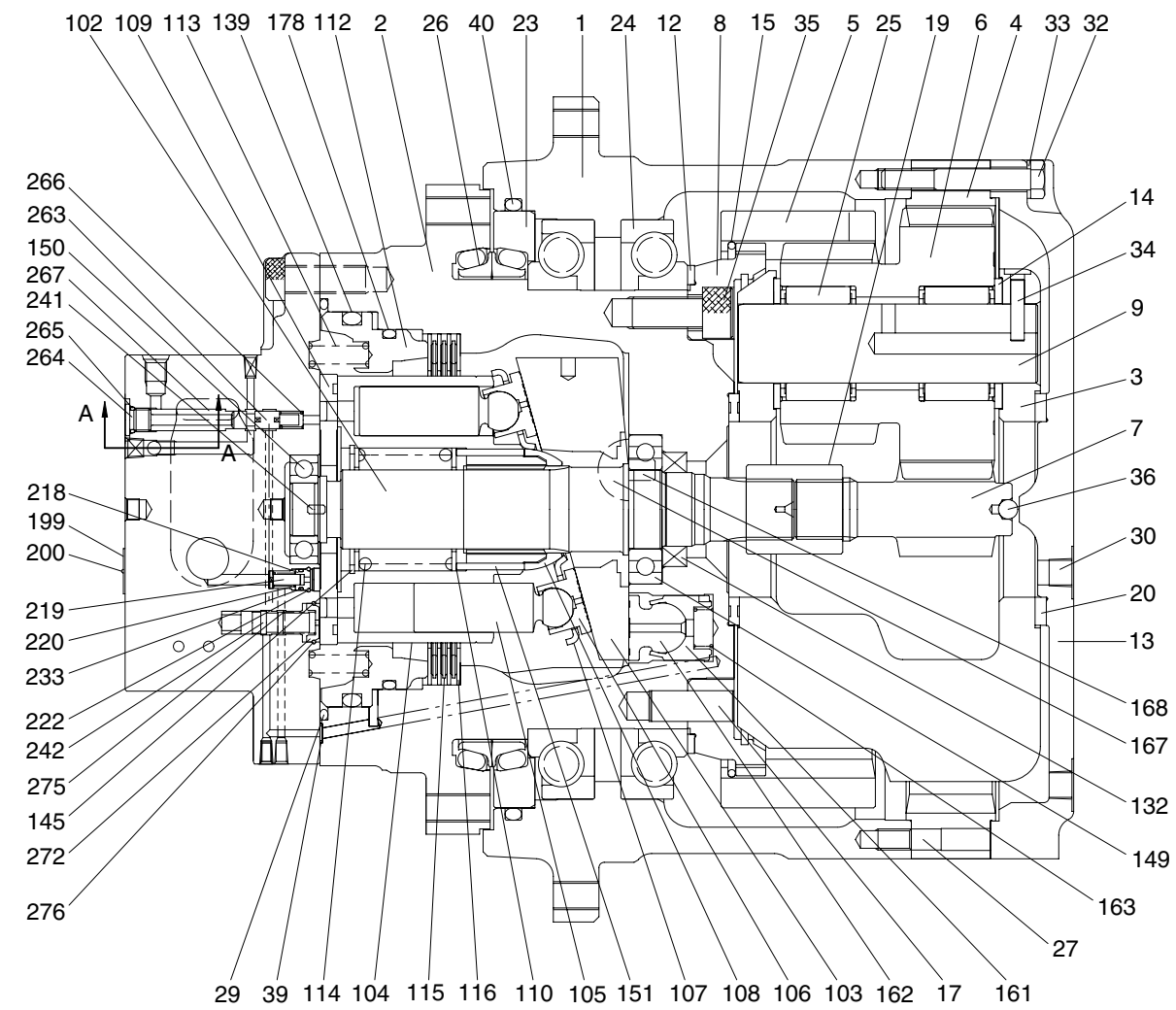

1 Hub	19 Coupling	39 O-ring	115 Friction plate	181 Parallel pin	263 2 speed spool	297 Orifice
2 Spindle	20 Thrust plate	40 O-ring	116 Mating plate	201 Rear flange	264 RO plug	298 Stopper
3 Carrier	23 Seal ring	102 Shaft	132 Oil seal	224 Stopper	265 O-ring	301 Seat
4 Ring gear A	24 Ball bearing	103 Swash plate	139 O-ring	226 Plug	266 Spring	302 Plunger
5 Ring gear B	25 Needle bearing	104 Cylinder block	145 Snap ring	227 Check valve	267 Set screw	303 Rod
6 Cluster gear	26 Floating seal	105 Piston	149 Ball bearing	228 Spring	268 Steel ball	304 Piston
7 Sun gear	27 Pin	106 Shoe	150 Ball bearing	230 Spring	272 Valve seat	305 Body
8 Coupling gear	29 O-ring	107 Retainer plate	151 Roller	233 O-ring	275 Spring	306 Plug
9 Shaft	30 PT plug	108 Thrust ball	161 Piston	234 O-ring	276 Ring	307 Spring
12 Distance piece	32 Hexagon bolt	109 Timing plate	162 Shoe	238 O-ring	279 O-ring	308 Shim
13 Cover	33 Spring washer	110 Washer	163 Spring	241 Pin	282 Hexagon socket bolt	309 O-ring
14 Thrust collar	34 Pin	112 Piston	167 Pivot	242 Valve	294 Stopper	310 O-ring
15 Ring	35 Hexagon socket bolt	113 Spring	168 Parallel pin	244 PT plug	295 Spool	311 Back up ring
17 Pin	36 Steel ball	114 Spring	178 O-ring	252 PT plug	296 Spring	

1807A2TM03

## 1) TOOLS AND TIGHTENING TORQUE

### (1) Tools

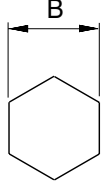
Tool name	Remark	
Allen wrench	6	
	10	
	14	
Socket for socket wrench, spanner	19	
	41	
Torque wrench	Capable of tightening with the specified torques.	
Pliers	-	
( - ) Driver	150mm	
Plastic and iron hammer	Wooden hammer allowed. Nominal 1 or so	
Steel rod approx	7 × 7 × 200mm	
Monkey wrench	-	
Oil seal inserting jig	-	
Bearing pliers	-	
Seal tape	-	
Eye bolt	M10	
Press (0.5 ton)	-	
Oil stone	-	
Bearing assembling jig	-	
Liquid packing	Loctite #577	
Screw lock	Loctite #243	

### (2) Tightening torque

Part name	Item	Size	Torque	
			kgf · m	lbf · ft
Hexagon socket plug	30	PT-1/2	10±2	72.3±14.5
Hexagon bolt	32	M12	10.4±1.6	75.2±11.6
Hexagon socket bolt	35	M18	35.5±5.5	256.8±39.8
Plug	221	PF 1/2	10±2	72.3±14.5
Plug	224	M45×1.5	51±7.5	369±54.2
Plug	226	M36×1.5	26±4	188.1±28.9
Plug	253	PF-1/4	3.0±0.5	21.7±3.6
Plug	154, 169	NPTF 1/16	1.0±0.25	7.2±1.8
Hexagon socket bolt	282	M16×2.0	25.7±4	185.9±28.9

### **3. DISASSEMBLY**

#### **1) GENERAL PRECAUTIONS**

- (1) Before disassembling the motor, check the items to be inspected and, for remedy against trouble, closely examine the nature of the trouble, so that the motor can be disassembled effectively.
- (2) To disassemble the motor, use the disassembling procedures described in section 2 and select a clean place.
- (3) Place a rubber or vinyl sheet or other such protective materials on your working bench to protect the surface of the motor to be serviced.
- (4) During disassembly, give a match mark to the mating surfaces of each part.
- (5) Arrange removed parts in order so that they will not become damaged or missing during disassembly.
- (6) Once seals have been disassembled, they should be replaced even if damage is not observed. Have replacement seals ready on hand before starting your disassembling job.

## 2) DISASSEMBLING PROCEDURE

### (1) Disassembling the brake valve section and the hydraulic motor section

- ※ When inspecting or repairing the motor, use the disassembling procedures described below.
- ※ Numbers in parentheses ( ) following the part name denote the item numbers shown in the attached assembly drawings.
- ※ Prior to disassembly, install the motor on an inversion working bench.

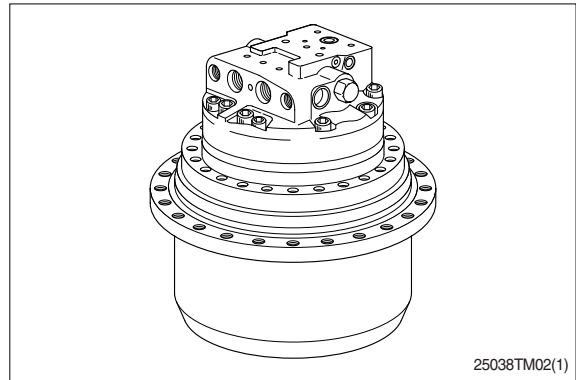

- ① Remove the relief valve from the rear flange (201).
  - Wrench : 17mm

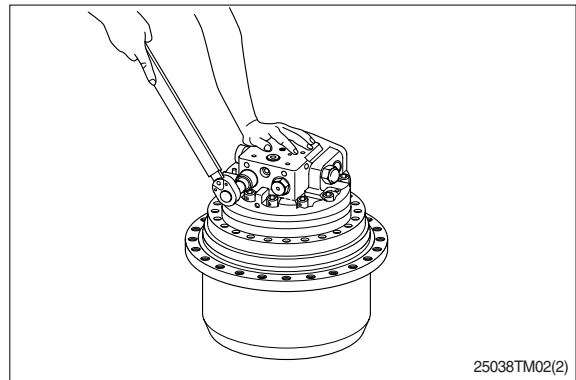

- ② Remove the nine hexagon socket head bolts (282).

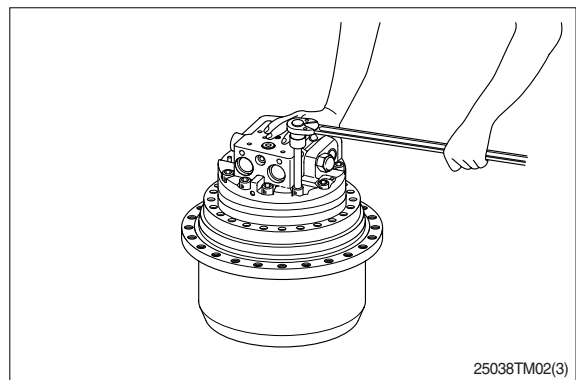

- ③ Remove the rear flange (201) from the spindle (2).

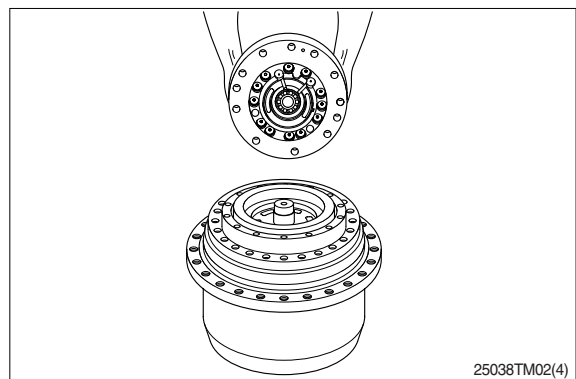

- ④ Remove the timing plate (109), the two pins (168), the nine spring (113) and the ball bearing (150) from the rear flange (201) and hydraulic motor.
- ⑤ Remove the two O-ring (29) and O-ring (39) from spindle (2).
- ※ Do not reuse the O-rings (29, 39) after removal.

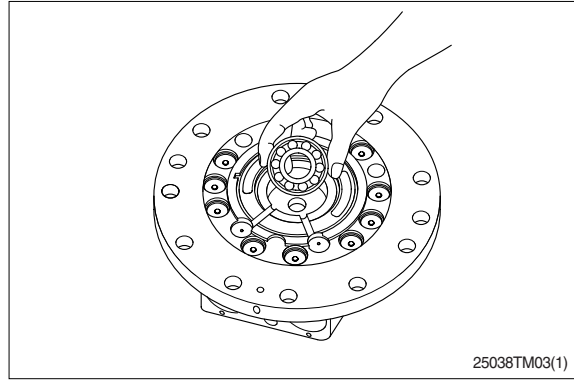

**(2) Disassembling the reduction gear/  
Hydraulic motor shafts and oil seals**

- ① Turn the motor and cover (13) over.
- ② Remove three plugs (30).
- ③ Remove twelve hexagon socket head bolts (32).

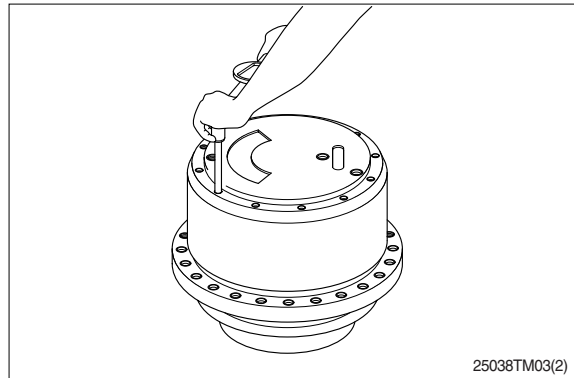

- ④ Install two eye bolt (PF 1/2) to the threads for plugs (30).
- ⑤ Fasten hook to the eye bolts then lift up cover (13).
- ※ When cover (8) do not come up easily due to friction of O-ring (30), bang cover (8) evenly using a plastic hammer.
- ⑥ Drain lubricating oil from the reduction gear.

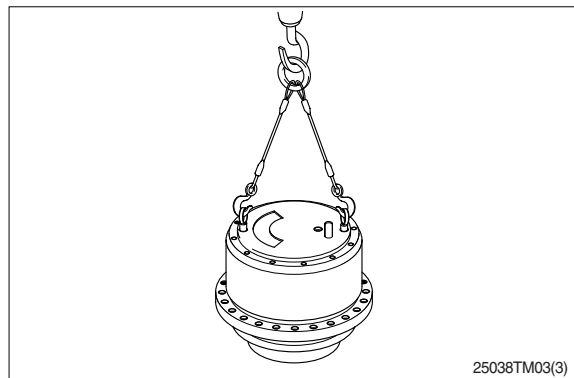

### 3) DISASSEMBLY OF BRAKE VALVE

#### (1) Disassembly of the spool

- ① Remove the two plugs (224) from the rear flange (201).

Remove the two O-ring (279) from the plug (224).

- ※ Removal of the two plugs (224) from the rear flange (201) can better be done by loosening the former beforehand with the latter connected to the spindle (2).

- ※ Do not reuse the O-ring (279) after removal.

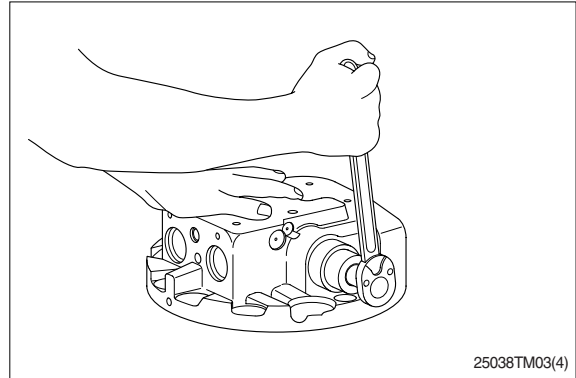

- ② Remove the two springs (228), the two stoppers, and the spool (223) from the rear flange (201).

- ※ Be careful not to damage the outer surface of the spool (223) and the sliding surface of the rear flange (201).

- ※ Since the rear flange (201) and the spool (223) are of the selective fitting type, replace them together as a kit even if only one of the two parts is damaged.

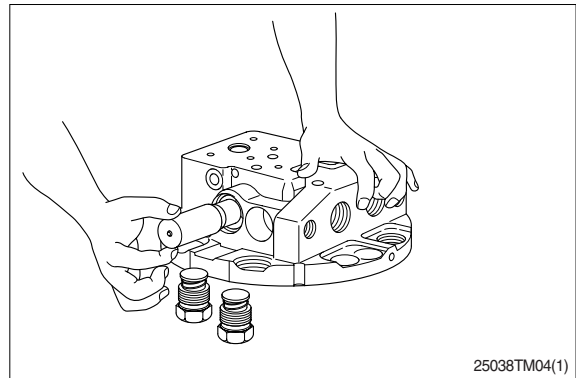

#### (2) Disassembly of the check valves

- ① Remove the two plugs (226) from the rear flange (201).

- ※ Removal of the two plug (226) from the rear flange (201) can better be done by loosening the former beforehand with the latter remaining connected to the spindle (2).

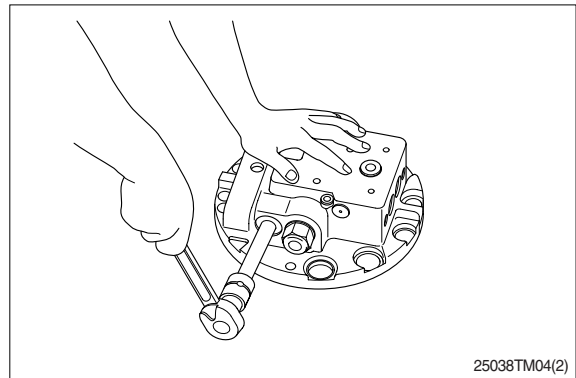

- ② Remove the two springs (230) and the two valves (227) from the rear flange (201).
- ※ Be careful not to damage the seat sections of the valves (227) or rear flange (201).
- ③ Remove the O-ring (234) from the plug (226).
- ※ Do not reuse the O-ring (234) after removal.

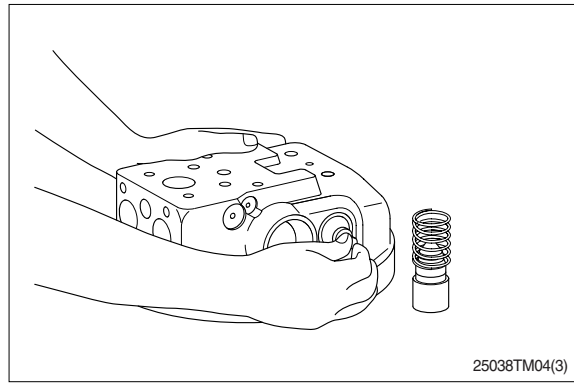

### (3) Disassembly of the two valve (263)

- ① Remove the plug (264) and two valves (263) and the spring (266) from the rear flange (201).

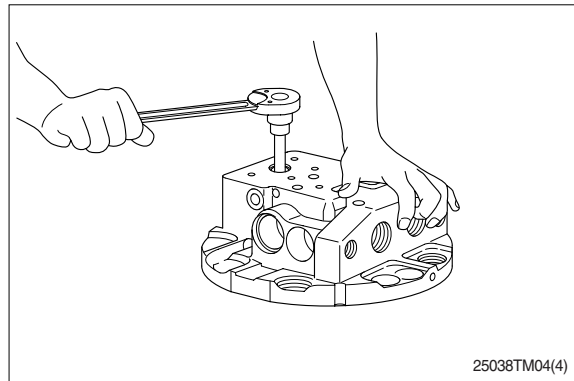

### (4) Disassembly of the reducing valve

- ① Press and hold down the valve seat (218) using a steel bar, and in that state, as shown in the figure, press the notch in the ring (222) using a sharp-pointed steel bar.

This deforms the ring (222), disengaging it from the ring groove in the rear flange (201).

The ring (222) can now be removed from the rear flange (201).

- ※ After disassembly, do not reuse ring (272).
- ※ Removing the ring (272) damages the hole section.
- ※ Repair the hole section after disassembly.
- ※ Remove the ring (222) only when the valve (219) is to be replaced.

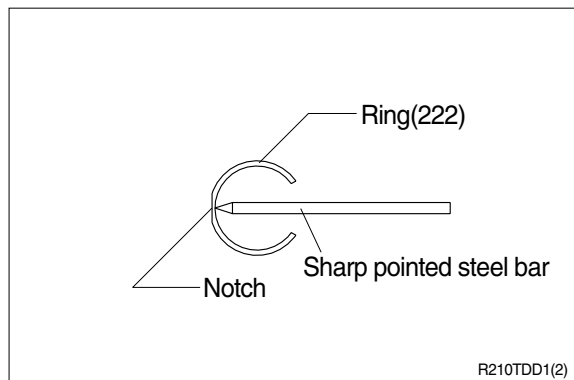
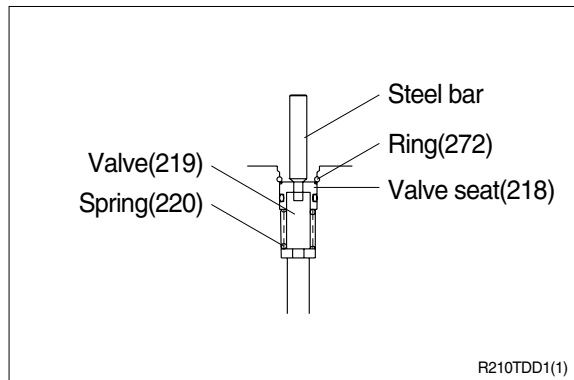



#### 4) DISASSEMBLY OF HYDRAULIC MOTOR

##### (1) Disassembly of the parking brake

① Remove the piston (112) by injecting compressed air from the parking brake access hole in the spindle (2).

※ Take care that abrupt injection of compressed air (3~5kgf/cm<sup>2</sup>) may cause the piston (112) to pop out.

To ensure your safety, apply a protective cover to the piston.

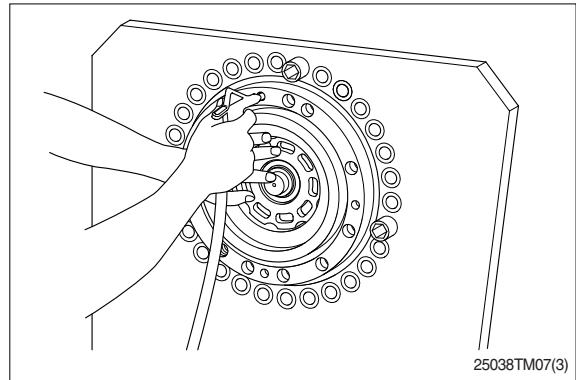

② Remove the two O-rings (139, 178) from the piston (112).

※ Do not reuse O-rings (139, 178) after removal.

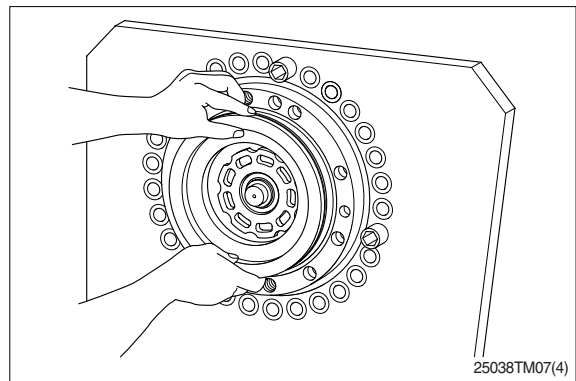

##### (2) Disassembly of the internal parts of the motor

① Lay the motor body on the side.

② Drain out the oil from the motor.

③ Hold the cylinder block (104) with both hands, and remove it from the spindle (2).

※ Place an oil receptacle under the motor to receive the oil flowing out as the motor is being laid on the side.

※ Before removal, hold the cylinder block (104) with both hands and turn it two or three times in a clockwise and a counterclockwise direction alternately to detach the shoe (106) from the swash plate (103).

Be careful that if an attempt is made to remove the cylinder block (104) without detaching the shoe (106) from the swash plate (103), then the piston, shoe, and other parts that are connected to the cylinder block may come loose and fall into the spindle.

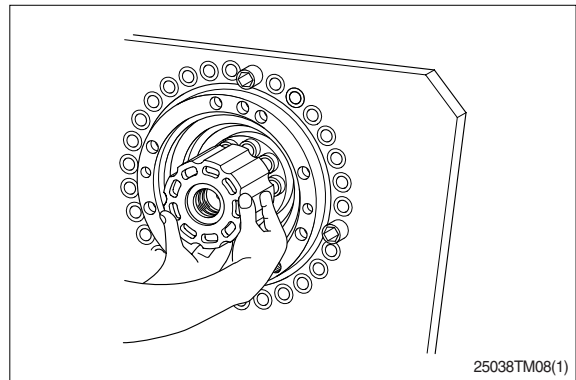

- ④ Remove the three friction plates (115) and four mating plates (116) from cylinder block (104).

Separate the piston assembly (105, 106),

- ⑤ retainer plate (107), thrust ball (108), and six rollers (151) from cylinder block (104).

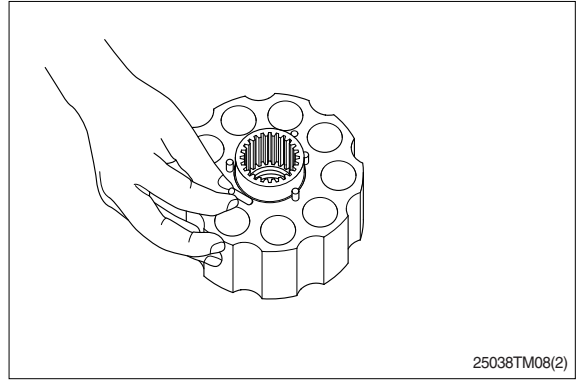

- ⑥ Remove the swash plate (103) from the spindle (2).

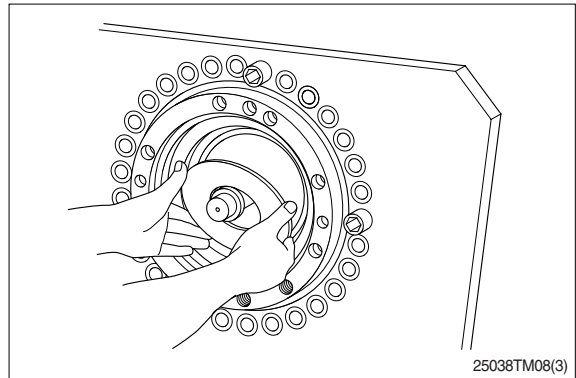

- ⑦ Remove the shaft (102) from the spindle (2). At this time, ball bearing (149) is also taken out together with shaft (102).

※ Oil seal (132) cannot be taken out.

※ Lightly shaft (102) end on the reduction gear side with a plastic hammer to make the removal easier.

Take notice when removing the shaft (102) rap strongly and swiftly, the shaft will come quickly free from the spindle.

- ⑧ Remove the two pivots (167) and the parallel pins (168) from spindle (2).

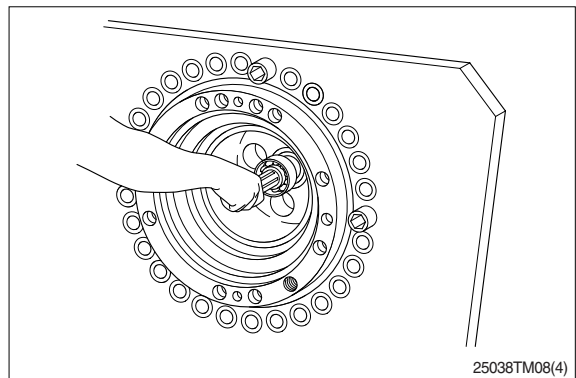

- ⑨ Remove the speed selector piston assembly by compressed air (3~5kgf/cm<sup>2</sup>) through the passage for the piston assembly in spindle (2).
- ※ Piston (161) and shoe (162) are included in the piston assembly and are not supplied one by one, therefore, the piston assembly should be replaced.
- ※ Abrupt compressed air causes the piston assembly to spring out which dangerous. The piston assembly can be taken out safely by putting a protective cover or the lie on it.

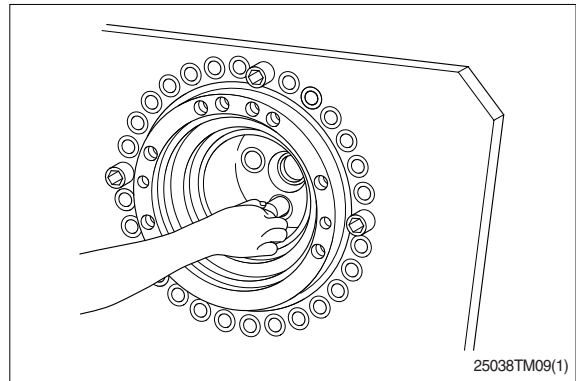

### (3) Disassembly of the cylinder block

- ① Place the cylinder block on the work bench and take out snap ring (145) with the snap ring pliers while pressing the retainer against washer (110).
- ※ Before compressing spring (114), make sure that cylinder block (104), retainer and press arbor are in good alignment: This is for galling or denting cylinder block (104).
- ※ Put a vinyl cover on the sliding surface of cylinder block (104) for protection.
- ② Slacking the press force slowly, until free of the spring force.
- ※ Do not remove spring (114) if it not to be replaced.
- ※ When disassembling there is a possibility that the spring may be injured. Slacking very slowly in order to prevent injury to the spring.

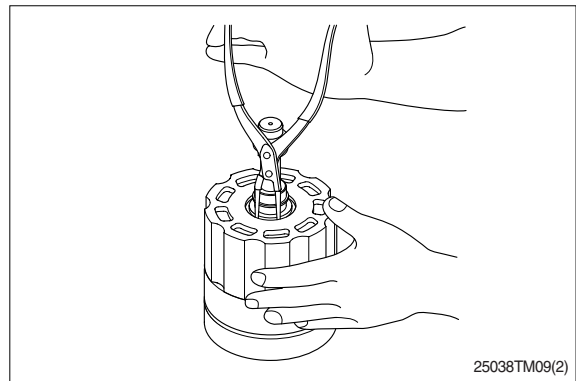

- ③ Remove the snap ring (145), washer (110), spring (114) and washer (110) from cylinder block (104).
- ※ Remove the spring (114) only if it is to be replaced.

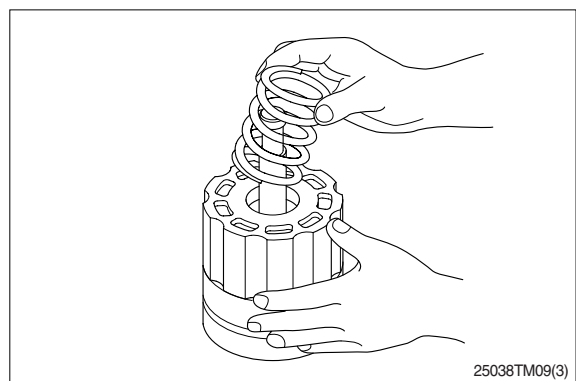

## 5) DISASSEMBLY OF REDUCTION GEAR

### (1) Disassembly of ring gear A (4)

- ① Before removing ring gear A, give an alignment match mark to both the ring gear and hub (1).
- ② Remove the ring gear A (4) using a crowbar or any other suitable tool.
  - ※ After ring gear A (4) has been removed, remove any adhesive residue from the mating surfaces of the ring gear and the hub.
- ③ Remove the ten dowel pins (27) from the hub (1).

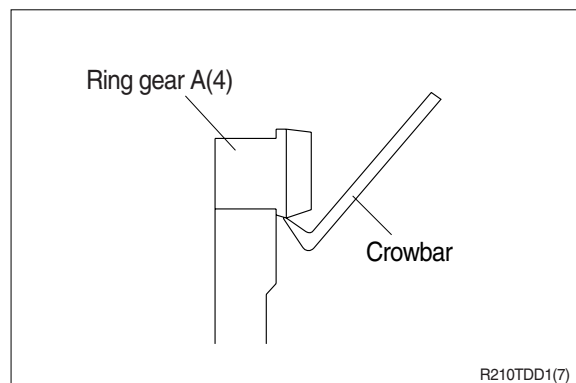
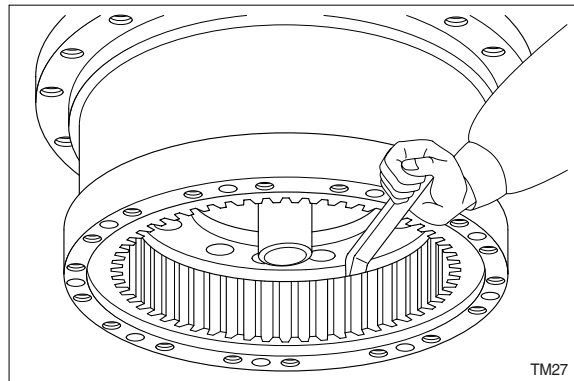

### (2) Disassembly of the hub (1), ring gear B (5), and the coupling gear (8)

- ① Remove the ten hexagon socket head bolts (35).
  - ※ Since the hexagon socket head bolts (35) have their threaded sections coated with an adhesive, a loosening torque larger than the tightening one is needed to remove the bolts.
  - ※ Tightening torque :  $35.5 \pm 5.5 \text{ kgf} \cdot \text{m}$   
( $256.8 \pm 39.8 \text{ lbf} \cdot \text{ft}$ )
  - ※ Be extra careful during removal not to let the threaded sections of the hexagonal socket head bolts (35) seize.
- ② Before removing the coupling gear (8) from the spindle (2), mark the mating surfaces of the coupling gear (8) and the spindle (2) using a paint marker.

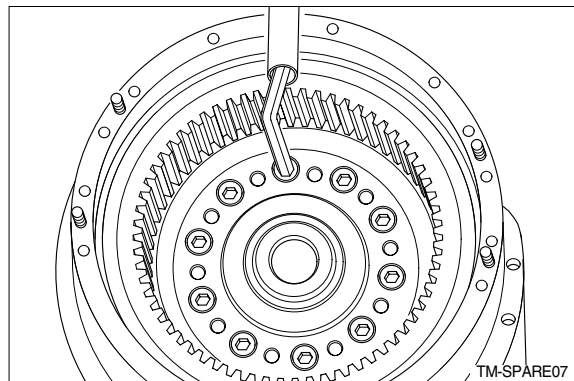

- ② Mount ring bolts in the M12 tapped holes of the hub (1), and then lift the hub (1) using lifter and separate the hub (1) and the spindle (2).

This also disconnects the two ball bearings (24), seal ring (23), O-ring (40), coupling gear (8), ring gear B (5), ring (15), and the distance piece (12).

- ※ Proceed as follows if disassembly is not possible with the method mentioned above :

- Rotate the motor through 180 degrees to let the spindle side of the motor face upward.
- As shown in the photo, lightly tap the edge of the hub (1) equally with an aluminum rod and a hammer until the hub (1) has become disconnected from the spindle (2).

This will also disconnect the following parts :

Two ball bearing (24), seal ring (23), O-ring (40), coupling gear (8), ring gear B (5), ring (15), distance piece (12).

- ※ Lay a rubber mat under the working bench to prevent damage to hub (1) and other parts due to possible fall from the working bench.

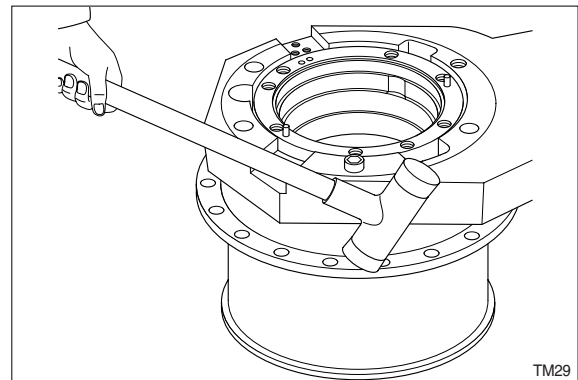
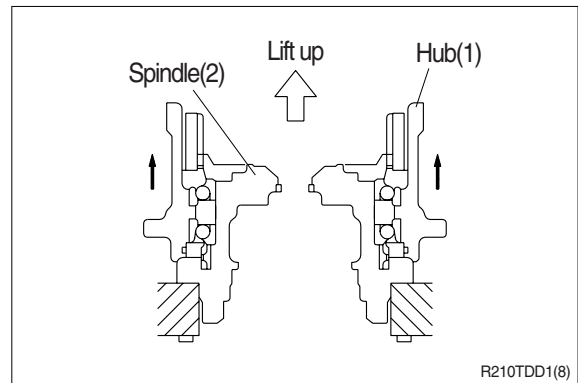

**(3) Disassembly of the inside of the spindle (2)**

- ① Remove the O-ring (29) from the spindle (2).
- ② Rotate the spindle (2) through 180 degrees.
- ③ Remove the oil seal (132) from the spindle (2).

(To remove the oil seal, set a (-) screwdriver at the cylindrical edge of the oil seal and lightly tap with a hammer.)

- ※ Do not reuse the O-ring (29) after removal.
- ※ Remove the oil seal (132) only if it is to be replaced.  
Do not reuse the oil seal (132) once it has been removed.

- ④ Remove the floating seal (26) from the spindle (2).

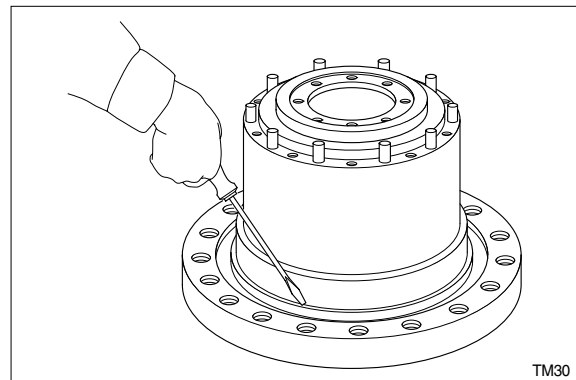
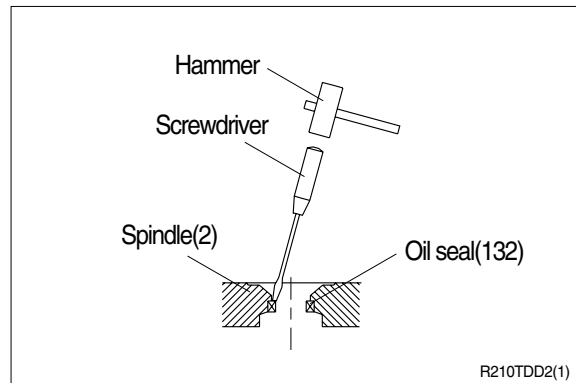

#### (4) Disassembly of the inside of the hub (1)

- ① Place the hub (1) on the working bench so that the cover side of the hub faces upward.

- ② Remove one of the two ball bearings (24) from the hub (1) as shown in the figure.

This also lets the seal ring (23) come

※ loose.

In principle, the ball bearings (24) should not be removed from the hub (1) since the former is shrinkage-fitted into the latter.

※ Do not reuse the ball bearings (24) after removal.

- ③ Place the hub (1) on the working bench so that the hub end facing the spindle points upward.

- ④ Remove the other ball bearing (24) from the hub (1) as shown in the figure.

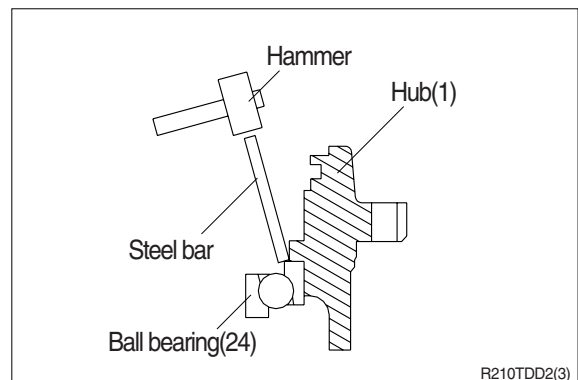
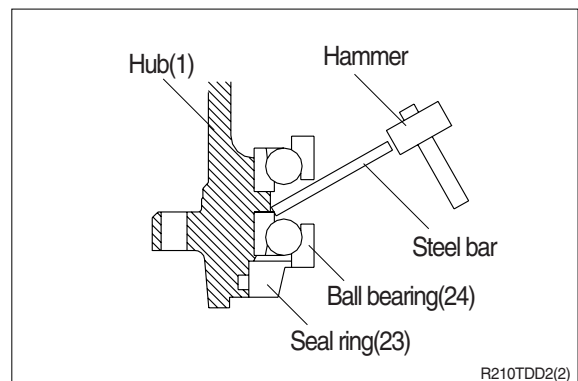

- ⑤ Remove the O-ring (40) from the hub (1).

※ Do not reuse the O-ring (40) after removal.

### (5) Disassembly of the coupling gear (8)

- ① Remove the ring (15) from ring gear B (5).
- ※ Do not reuse the ring (15) after removal.

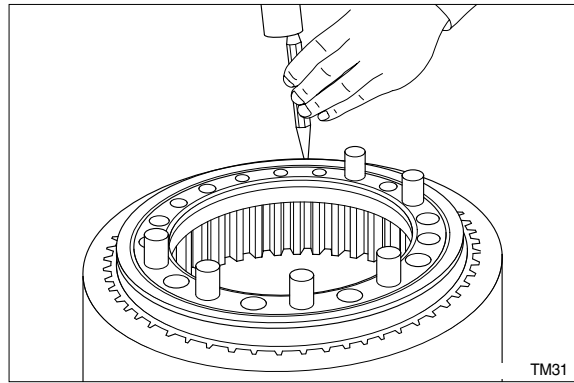

- ② Remove the coupling gear (8) from ring gear B (5).
- ※ Except for their replacement, do not disassemble the coupling gear (8) or ring gear B (5).

### (6) Disassembly of the carrier assembly

- ① Do not disassemble the carrier assembly any further.  
If a component of the carrier assembly is irrecoverably damaged, replace the entire carrier assembly with a new one.
- ※ Components of the carrier assembly
- Carrier (3)
  - Cluster gear (6)
  - Shaft (9)
  - Thrust collar (14)
  - Needle bearing (25)
  - Dowel pin (34)

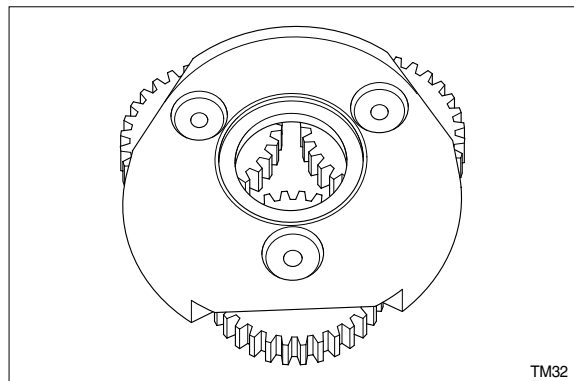



## 4. ASSEMBLY

### 1) GENERAL PRECAUTIONS

- (1) Reassemble in a work area that is clean and free from dust and grit.
- (2) Handle parts with bare hands to keep them free of linty contaminants.
- (3) Repair or replace the damaged parts.  
Each parts must be free of burrs its corners.
- (4) Do not reuse O-rings, oil seal and floating seal that were removed in disassembly.  
Provide the new parts.
- (5) Wash all parts thoroughly in a suitable solvent.  
Dry thoroughly with compressed air.  
Do not use the cloths.
- (6) When reassembling oil motor components of motor, be sure to coat the sliding parts of the motor and valve with fresh hydraulic oil. (NAS class 9 or above)
- (7) Use a torque wrench to tighten bolts and plugs, to the torque specified as follows.

## 2) ASSEMBLY OF BRAKE VALVE

### (1) Assembly of the check valve

- ① Fit the O-ring (234) on the plug (226).
  - ② Insert the spring (230) and the valve (227) into the plug (226), and then grease the spring (230) and the valve (227) and hand-lock the former.
  - ③ Insert the plug (226) in conjunction with the spring (230) and the valve (227) into the rear flange (201), and tighten the plug to the required torque.
- ※ Apply grease to the O-ring (234).
  - ※ Tighten the plug (226) to a torque of  $26 \pm 4 \text{ kgf} \cdot \text{m}$  ( $188 \pm 29 \text{ lbf} \cdot \text{ft}$ ).

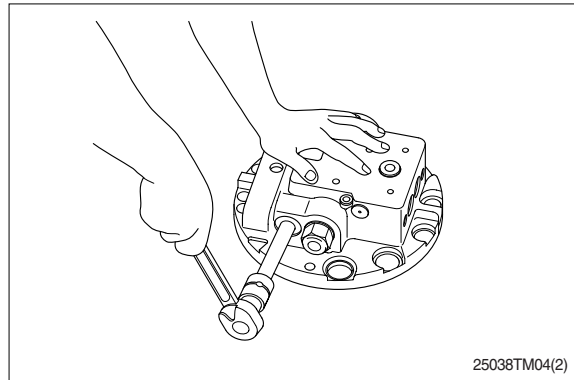

### (2) Assembly of the spool

- ① Insert the spool (223) into the rear flange (201).
- ※ Apply a working fluid to the spool (223) and insert it into the rear flange (201).
  - ※ The spool must be remounted with its axial center accurately in line with the hole center of the rear flange. This prevents the inner surface of the rear flange and the outer surface of the spool from damage due to their contact.
- ② Attach the O-ring (279) to the plug (224).
  - ※ Apply grease to O-ring (279).

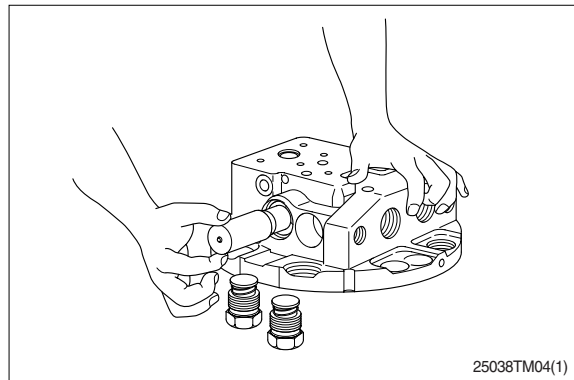

- ③ Install stopper (225) and the spring (228) into both plugs (224) and tighten the plugs (224) into the rear flange (301) at the required torque.
- ※ Required torque :  $51 \pm 7.5 \text{ kgf} \cdot \text{m}$   
( $369 \pm 54.2 \text{ lbf} \cdot \text{ft}$ )
  - ※ Even if either the rear flange (201) or the spool (223) is to be replaced, their entire assembly (kit) must be replaced.

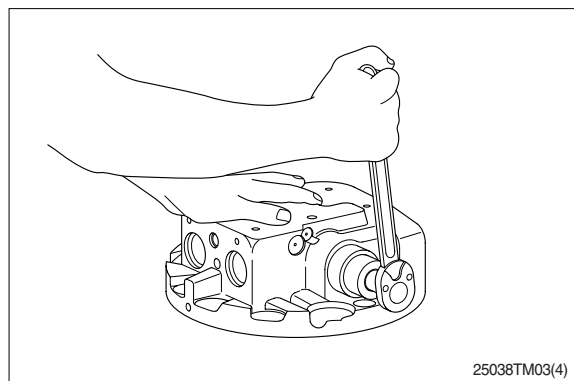

### (3) Assembly of the two-speed control valve

① Insert the plug (264) and the two valves (263) and the spring (266) from the rear flange (201).

※ Tightening torque :  $3 \pm 0.5 \text{ kgf} \cdot \text{m}$   
( $21.7 \pm 3.6 \text{ lbf} \cdot \text{ft}$ )

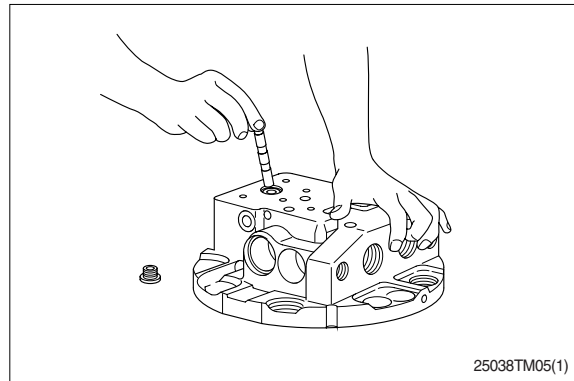

### (3) Assembly of the valve (142)

① Assemble the reducing valve assembly, the valve seat (272), and the spring (275) into the rear flange (201).

※ Press and hold down the valve seat (272) using a steel bar, and in that state, mount the ring (276) in the ring groove of the rear flange (201).

The ring (276) will remain deformed while inside the rear flange (201).

Before inserting the ring (276) into the ring groove of the rear flange (201), therefore, both ends of the ring must be extended using snap-ring pliers.

The ring (276) must be a new one.

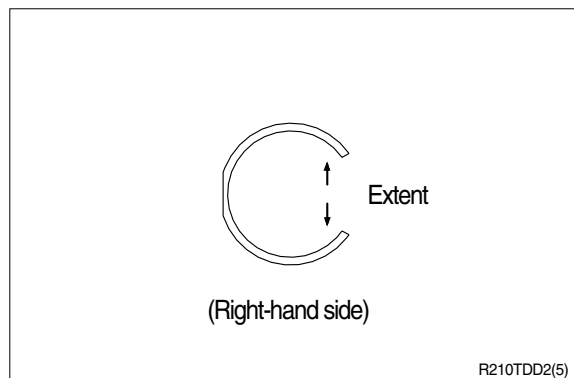
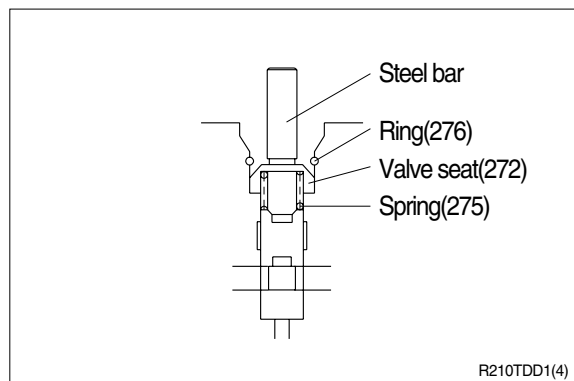

### 3) ASSEMBLY OF REDUCTION GEAR AND HYDRAULIC MOTOR

- ※ Before reassembling the reduction gear and the hydraulic motor following completion of parts replacement, one of the following two operations must be carried out:
  - Selecting a distance piece (12) of the appropriate thickness.
  - Selecting a thrust bearing (20) of the appropriate thickness.
- ※ Reassembling must be down only after clearance adjustment of these parts.
- ※ Prior to the start of reassembling, check for parts that require replacement.

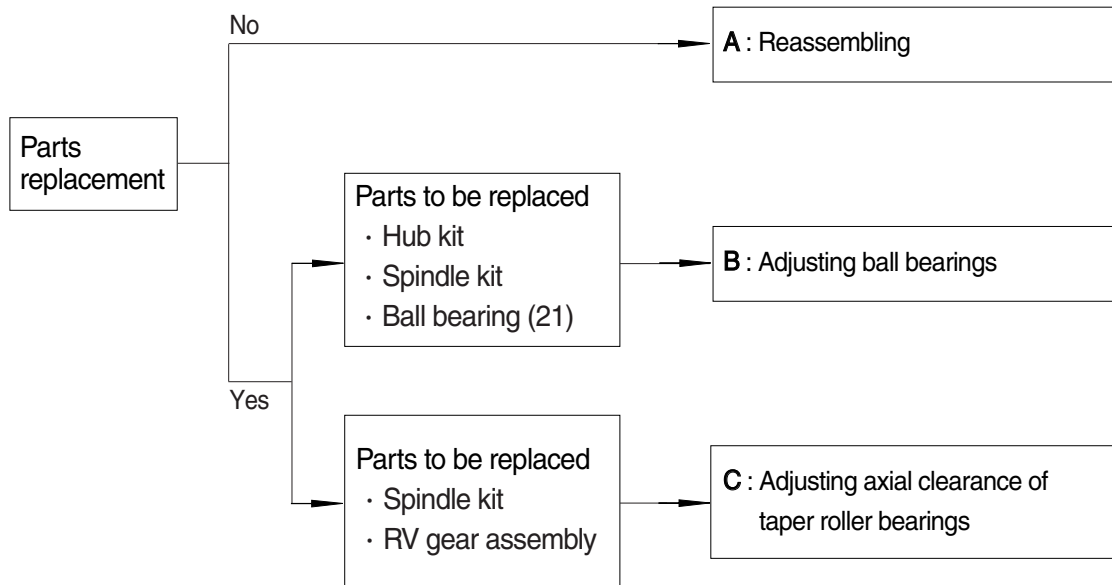

- ※ When the parts listed above are to be replaced, use correctly preadjusted parts as the replacement ones.
- ※ Reassembling with nonadjusted parts may cause motor malfunctions, resulting in early damage.

## A : REASSEMBLING

### (1) Assembly of the hub section

- ① Mount the hub (1) on a working bench so that the mounting side of the cover (13) faces upward.
- ② Insert the ball bearing (24) into the hub (1) using a force-fitting jig.
  - ※ Heat the hub (1) to a temperature of  $90 \pm 5^{\circ}\text{C}$ .
  - ※ Shrinkage-fit the ball bearing (24).
  - ※ If a force-fitting jig is not available, insert the ball bearing (24) into the hub (1) and then hammer the former.
- ③ Rotate the hub (1) through 180 degrees to make the mounting side of the spindle (2) face upward.
- ④ Insert the ball bearing (24) into the hub (1) using a force-fitting jig.
  - ※ Shrinkage-fit the ball bearing (24).
- ⑤ Assemble the O-ring (40) into the hub (1).
  - ※ Apply a thin coat of grease to the O-ring (40).
- ⑥ Assemble the seal ring (23) into the hub (1).

The seal ring can better be assembled into the hub by tapping the edge of the seal ring lightly with a plastic hammer.

  - ※ When assembling the seal ring (23) into the hub (1).
  - ※ Be extra careful not to damage the O-ring (40).

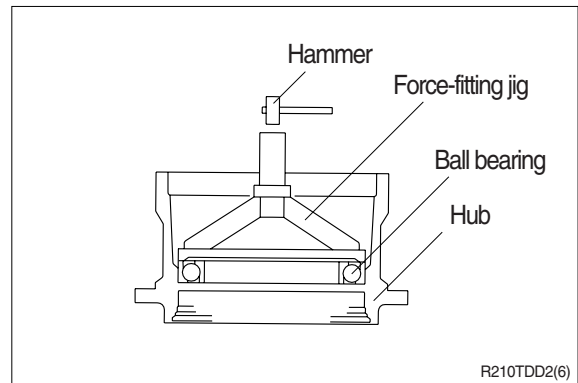

## (2) Assembly of the spindle (2) section

- ① Mount the two floating seals (26) in the spindle (2).
- ※ Apply a thin coat of grease to the O-ring in the floating seal (26).
  - ※ Be extra careful to ensure that dust does not stick to the seal surface.

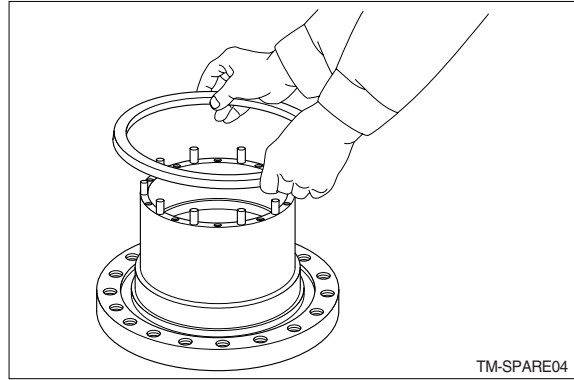

## (3) Assembly of the hub (1) and the spindle (2)

- ① Mount the spindle (2) on a working bench so that the cover side of the spindle faces upward.
  - ② Fit eye-bolts to the hub (1), and then lift it with a crane and gently insert it into the spindle (2).
- ※ If the hub (1) or the spindle (2) does not snugly fit because of the presence of the ball bearing (24) evenly tap the top of the hub (1) with a plastic hammer during fitting.

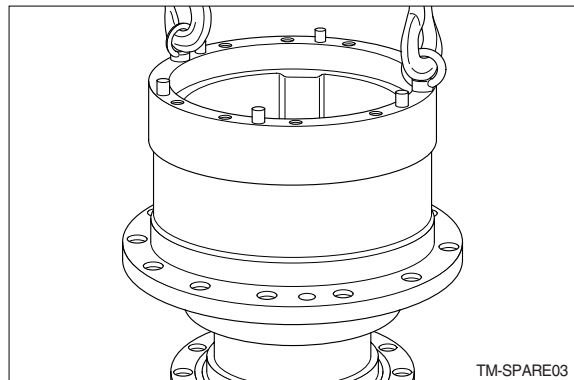

## (4) Assembly of the coupling gear (8) and ring gear B (5)

- ① Mount the coupling gear (8) in ring gear B (5).
  - ② Fit the ring (15) into the ring groove of ring gear B (5).
- ※ Do not reuse the ring (15) after removal. Use a new one during reassembling.

## (5) Assembly of the coupling gear (8)

- ① Attach a distance piece (12) to the coupling gear (8) using grease.
- ※ During attachment, apply a thin coat of grease to the mounting surface of the coupling gear (8) to prevent possible fall of the distance piece (12).

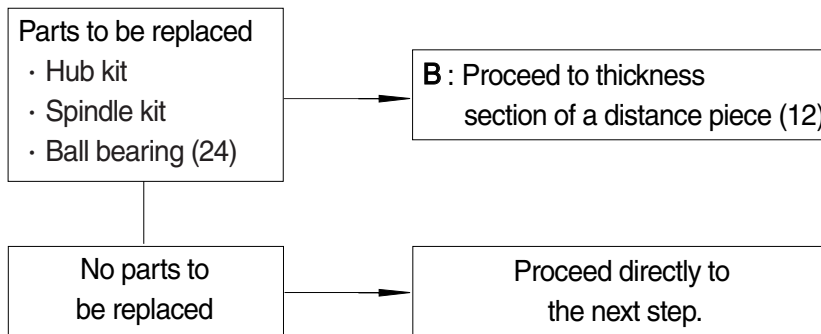

- ② Mount the coupling gear (8) (fitted with ring gear B (5)) on a coupling gear lifter, and then lift it with the crane and mount it in the spindle.
- ③ Match the match marks on the coupling gear (8) and the spindle (2).
- ④ Insert the ten pins (17), and caulk the pin hole edges of the coupling gear (8).
- ※ Do not reuse the pins (17) after removal. Use new ones during reassembling.

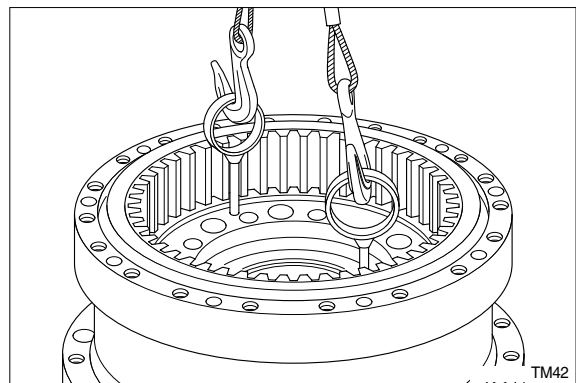

- ⑤ Tighten the ten hexagonal socket bolts (35) to the required torque using a torque wrench.
- ※ Tightening torque :  $35.5 \pm 5.5$  kgf · m  
( $256.8 \pm 39.8$  lbf · ft)
- ※ Apply an adhesive to the threaded section of the spindle (2) and the pin holes after degreasing both.
- ※ After completely degreasing the hexagonal socket bolts (35), apply molycoat to the bottom of each such bolt neck.
- ⑥ Rotate the motor through 180 degrees to make the spindle side face upward.

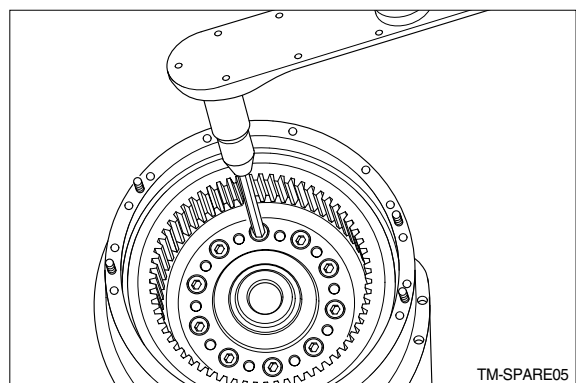

### (6) Assembly of the oil seal (132)

- ① Fit the oil seal (132) into the oil seal mounting hole of the spindle (2).
- ※ Apply white petrolatum or lithium grease to the lip section of the oil seal (132).
- ※ Use a new oil seal during reassembling.

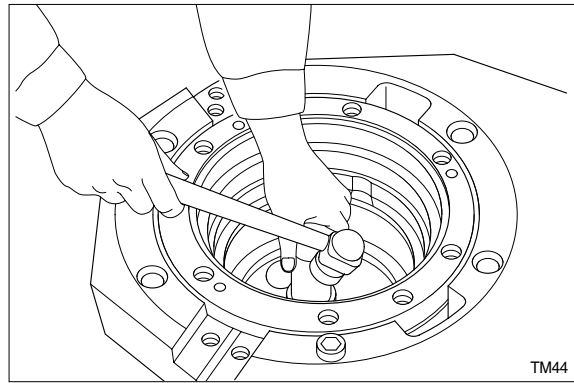

### (7) Assembly of the ball bearing (149)

- ① Shrinkage-fit the ball bearing (149) onto the shaft (102).
- ※ If the ball bearing (149) has been removed from the shaft (102) during disassembling, replace the former with a new one and then shrinkage-fit it onto the shaft (102).
- ※ Shrinkage-fitting temperature :  
 $100 \pm 10^{\circ}\text{C}$ .

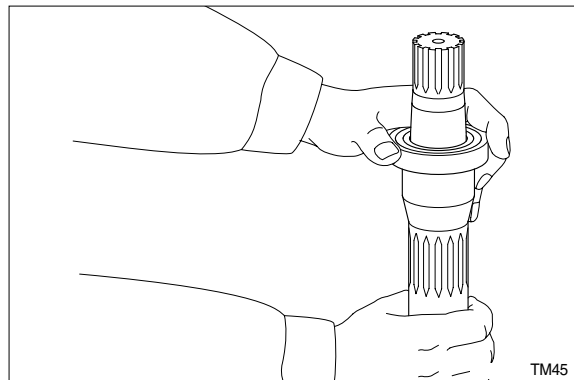



**(8) Assembly of the piston assembly (161, 162)**

- ① Mount the piston assembly (161, 162) in the piston hole of the spindle (2).

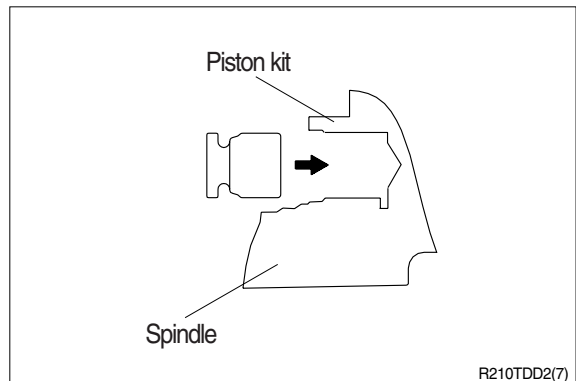
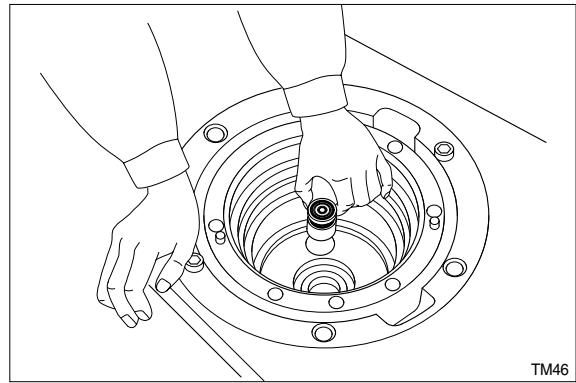

**(9) Assembly of the pivot (167)**

- ① Mount the two parallel pin (168) and two pivot (167) in the pivot hole of the spindle (2).

**(10) Assembly of cylinder block section**

- ① Insert washer (110), spring (114), washer (110) and snap ring (145) in that order, into the shaft bore of cylinder block (104).

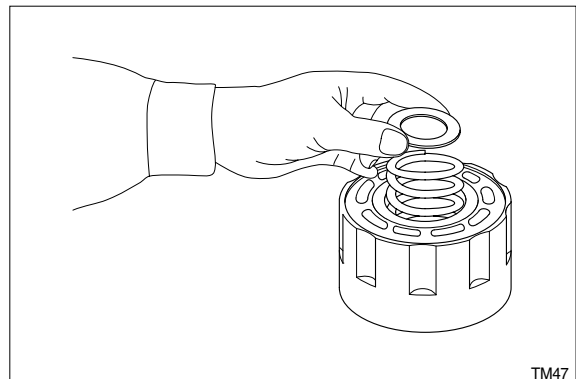

- ② Set cylinder block in the press in order to compress the spring (114).

Place retainer on the washer (110) and push down this tool with the press arbor until the snap ring groove becomes cleared.

Fit snap ring (145) into the groove.

- ※ When working on the cylinder block, protect its sliding face by covering it with a vinyl sheet.
- ※ A push of about 120 kgf (265 lbf) will be needed to compress the spring.

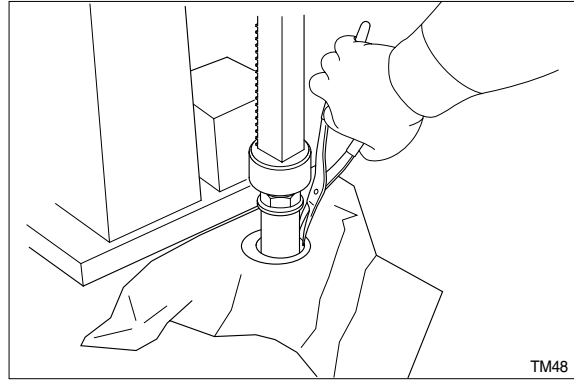

### (11) Assembly of piston motor sub assembly

- ① Fit six rollers (151) into the pin holes of cylinder block (104), and then, put thrust ball (108) on it.

- ※ Immerse piston assembly in hydraulic oil.

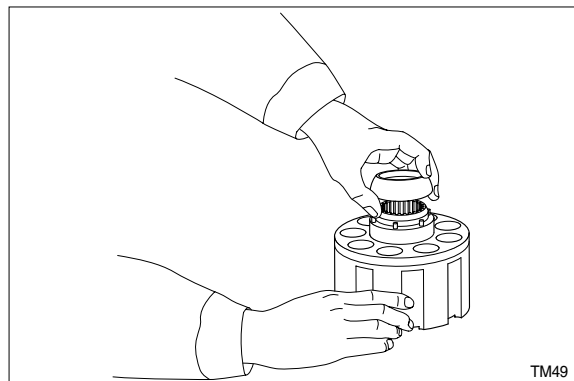

- ② Insert piston assembly into retainer plate (107).

- ③ Mount the piston assembly in the cylinder block (104).

After mounting, immerse the entire them in a working fluid.

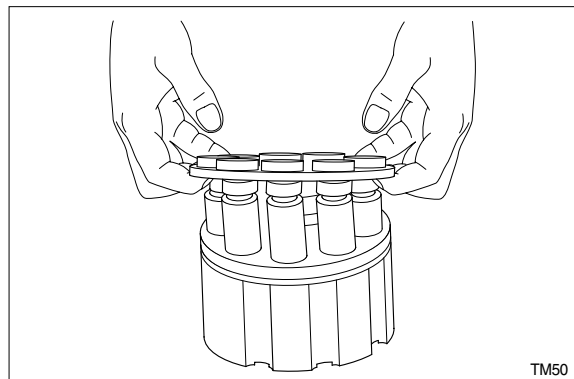

- ④ As shown in the figure, mount the swash plate (103), the thrust plate (153), the thrust ball (108), the retainer plate (107), the roller (151), the cylinder block (104), and the piston assembly (105,106) in the shaft (102).

Then, mount a lifter (II) and make the shaft (102) upright.

- ※ The outer lacing of the roller bearing (149) must be mounted in the spindle (2) beforehand.
  - ※ Accurately align and assemble the retainer plate (107) and the spherical section of the thrust ball (108).
- ⑤ Lift the motor assembly using a lifter, and mount it in the spindle (2).

- ※ Mounting must be done so that the steel-ball hole in the swash plate (103) and the steel ball (167) come into a fit. Mounting must also be done gently so that no parts come into contact with the spindle (2) or other sections.

Contact may damage parts.

- ※ After the motor assembly has been mounted, turn the cylinder block by hand to check for backlash. Perform inspections if back-lash is present.

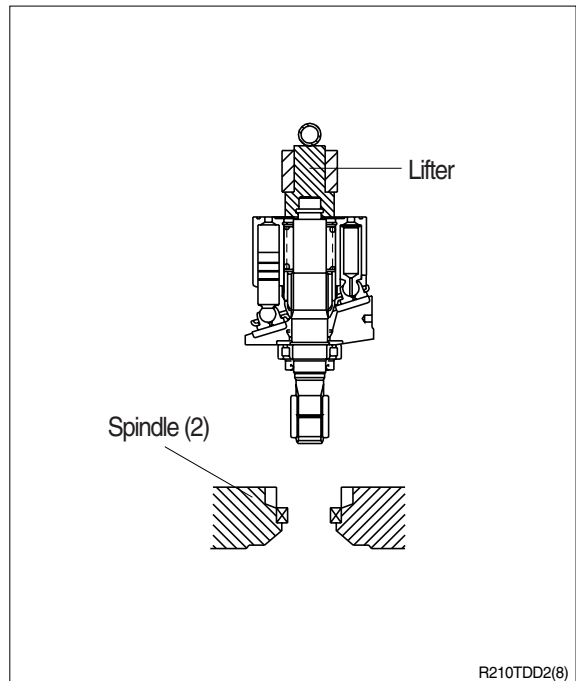
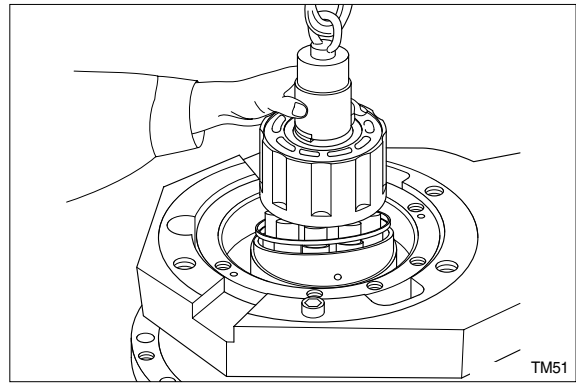

**(12) Assembly of the parking brake section**

- ① Fit the mating plate (116) first and then the friction plate (115), one by one, into the grooves of the outer surface of the cylinder block (104).
- ※ Immerse the friction plates (115) in a working fluid before fitting them into the grooves.

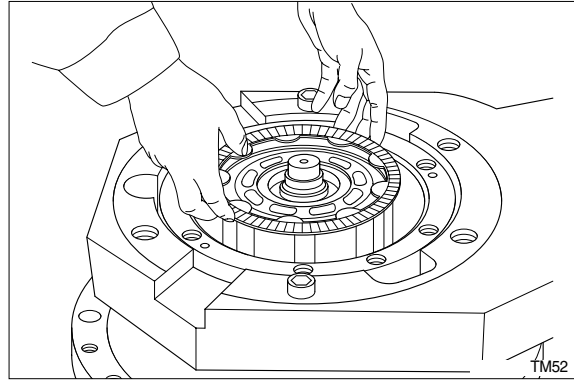

- ② Fit the O-rings (139,178) in the O-ring grooves of the piston (112).
- ※ Apply a thin coat of grease to the O-rings (139,178).

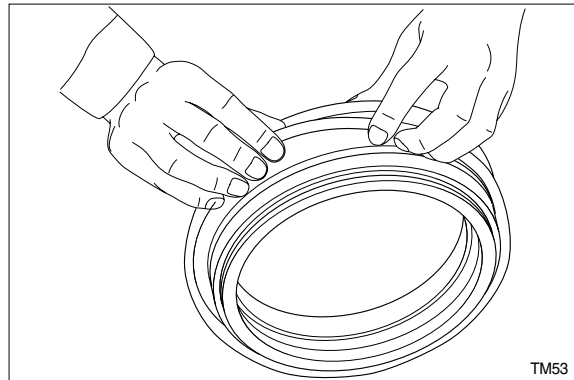

- ③ Mount the piston (112) in the spindle (2).  
If the piston (112) does not fit into the  
※ spindle (2) because of the resistance of  
the O-ring, tap the edge of the piston  
(112) lightly and equally with a plastic  
hammer.  
Be careful not to damage the O-ring at  
this time.

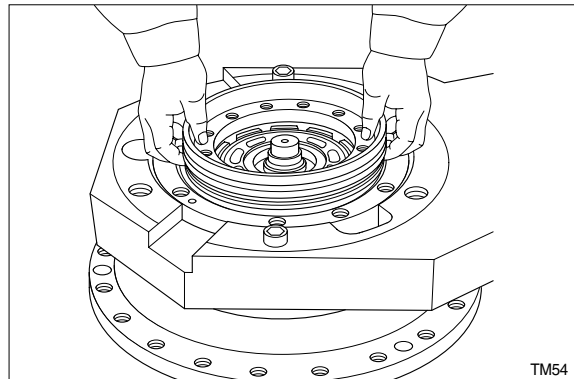

- ④ Mount the ball bearing (150) and timing plate (109) and parallel pin (241) and spring (113) into the rear flange (201).

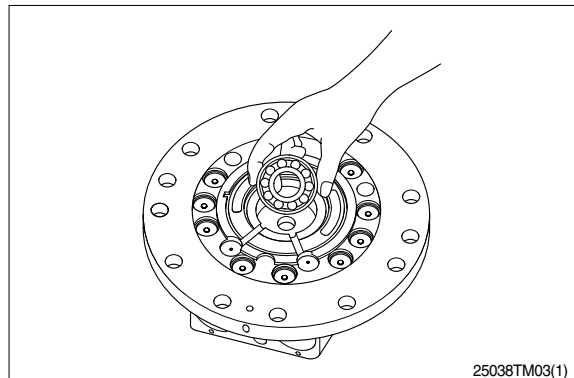



- ⑦ Mount the rear flange (101) on the spindle (2).

At this time, the two dowel pins that have been fitted into the spindle (2) must be aligned with the pin holes.

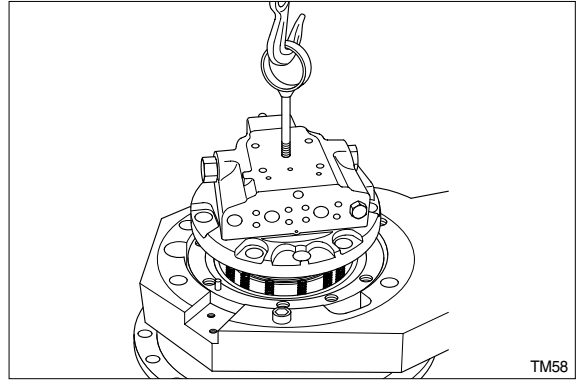

- ⑧ Tighten the nine hexagon socket head bolts (282) into the spindle (2) at the required torque.

※ Tightening torque :

$25.7 \pm 4 \text{ kgf} \cdot \text{m}$  ( $185.9 \pm 28.9 \text{ lbf} \cdot \text{ft}$ )

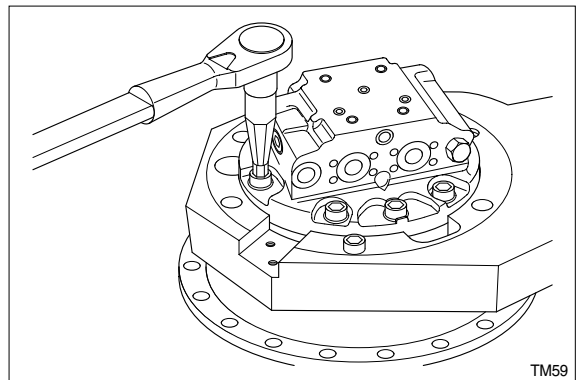

### (13) Assembly of the carrier assembly

- ① Attach one of the two thrust bearing (20) to the coupling gear (8) using grease.
- ※ Apply a thin coat of molybdenum disulfide grease to the thrust bearing (20).

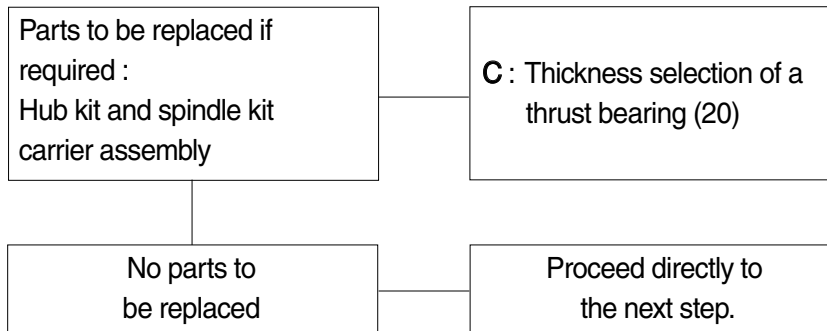

- ② Mount the coupling (19) on the shaft (102).
- ※ Apply a thin coat of molybdenum disulfide grease to the spline section of the coupling (19).

- ③ Place the steel ball (36) in the sun gear (7), and place the sun gear in the coupling (19).

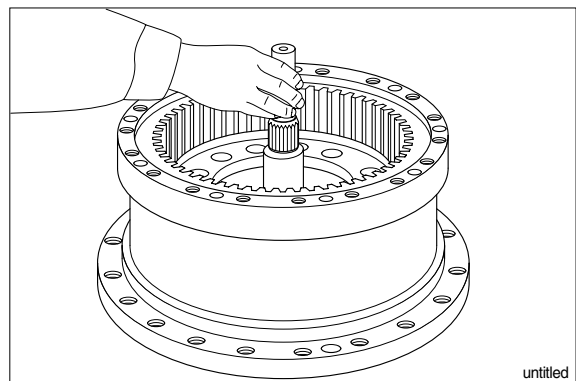

- ④ Insert the carrier assembly into the hub (1), and correctly engage the teeth of ring gear B (5) and teeth B of the cluster gear (6).
- ※ This must be done only after determining the timing point of carrier assembly reassembling (see next for further details).

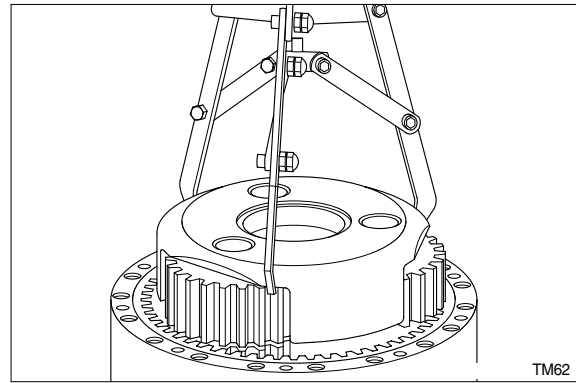

※ **Determining the timing point of carrier assembly reassembling**

To insert the carrier assembly into the hub (1) and correctly engage teeth B of the cluster gear (6) and the teeth of ring gear B (5), carry out the operating procedure described after this figure :

※ **Procedure**

- Align the match marks of the three cluster gears (6) at the positions shown.
- At those positions, engage the sun gear installer correctly with the cluster gears (6) and fix the sun gear installer.
- Insert the carrier assembly into the hub (1). This dismounts the sun gear installer automatically.

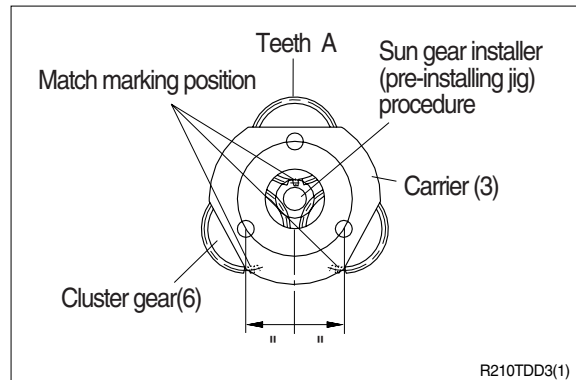

**(14) Assembly of ring gear A (4)**

- ① Mount ring gear A (4) on the hub (1). Check at this time that the teeth of ring gear A and teeth A of the cluster gear are in correct engagement.
- ② Rotate the hub (1) to fit the match marks on ring gear A and the hub.
- ③ Fit the ten dowel pins (27) into the hub (1).
- ※ After completely degreasing that surface of ring A (4) that contacts the hub (1), apply a thin coat #SS60F hermetic sealant to that contact surface.
- ④ Fill the reducer section with a lubricating oil.  
Quantity required : Approx. 3.3 liters

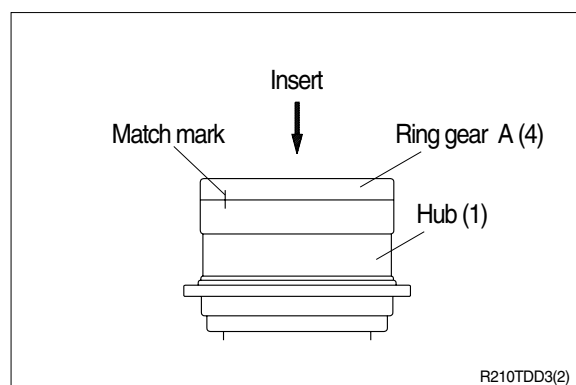



**(15) Assembly of the cover (13)**

- ① Attach the thrust bearing (20) to the carrier (3) using grease.
  - ※ Apply a thin coat of molybdenum disulfide grease to the surface of the thrust bearing (20).
  
- ② Install cover (8) to hub (1).
  - ※ Apply slightly three-bond No.1211 to that matching face of cover which is to mate with the surface of hub (1).

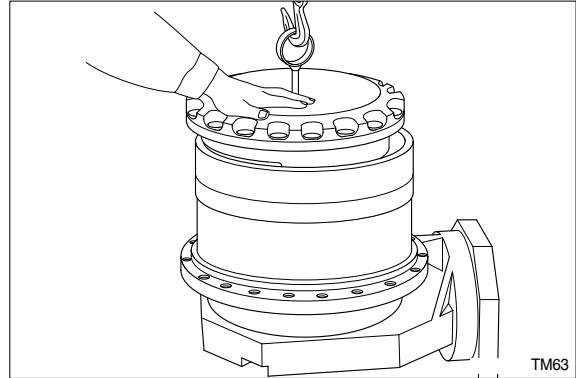

- ③ Fasten cover (13) to hub (1) with 20 hexagonal bolts (32) and 20 supper lock washers (33), applying to the specified torque.
  - ※ Tightening torque :  
 $10.4 \pm 1.6 \text{ kgf} \cdot \text{m}$  ( $75.2 \pm 11.6 \text{ lbf} \cdot \text{ft}$ )
  - ※ Before tightening bolts, apply loctite 242 to the hexagon bolts (32).
- ④ Tighten 3-plugs (30) to cover (13) to the specified torque.
  - ※ Tightening torque :  
 $10 \pm 2 \text{ kgf} \cdot \text{m}$  ( $72.3 \pm 14 \text{ lbf} \cdot \text{ft}$ )
  - ※ Before tightening plugs, wrap the threaded portion of each plug with two lagers of the seal tape.
  - ※ Tighten each plug until the last thread becomes nearly flush with the cover surface within an extent equal to plus or minus one thread relative to the surface.

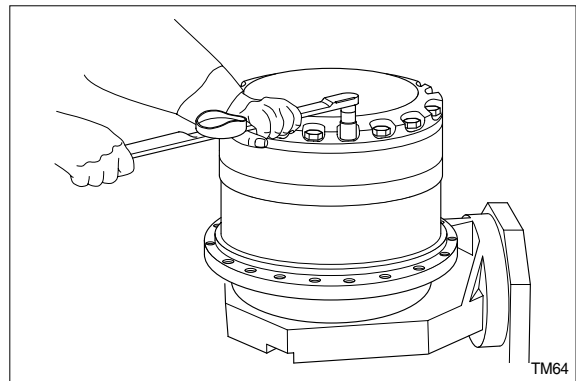

## B: THICKNESS SELECTION OF A DISTANCE PIECE (12)

(1) If the parts listed below have been replaced, select a distance piece (12) of the appropriate thickness.

After selection, return to the original reassembling procedure [procedure (5) of subsection 3] and carry out the next step of that procedure.

Parts replacement — { Hub kit  
Spindle kit  
Ball bearing (24)

(2) Steps (1) through (4) of the original reassembling procedure must be carried out as directed.

- ① Mount a measure plate on the spindle (2) without inserting a distance piece (12).
- ② Lightly tighten a few hexagon socket bolts (35).

③ As shown in the figure at right, measure dimension **A** using a depth micrometer.

※ Tighten the hexagon socket head bolts equally.

④ Measure dimension **C** of the coupling gear (8) to be mounted see the figure at right.

⑤ Using the clearance measurements, calculate the appropriate distance piece thickness as follows.

- Measure the clearance between the edge of the spindle (2) and that of the ball bearing (24).

Take this clearance as **X**.

$$X = A - B$$

- Next, determine the distance piece of the appropriate thickness.

Take this thickness as **T**.

$$T = (C + X) \pm 0.1$$

⑥ Using the results of steps (1) through (5) above, select the appropriate thickness.

Then, proceed with the original reassembling operation.

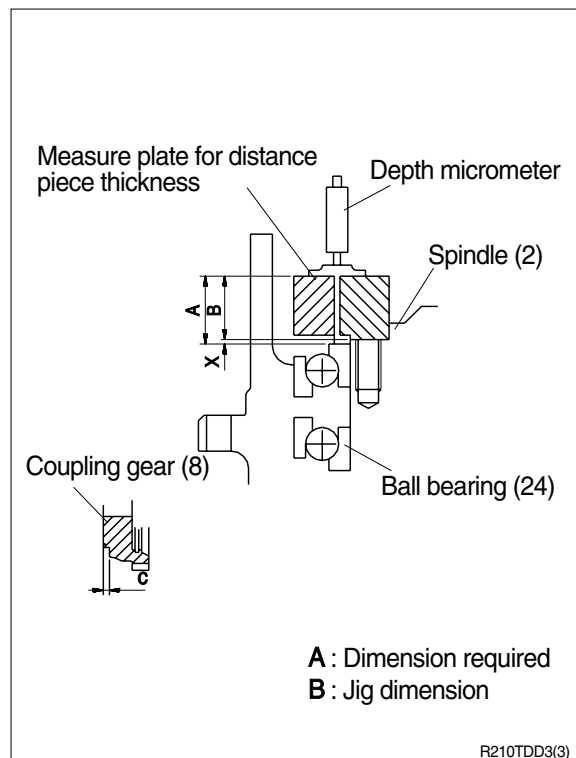
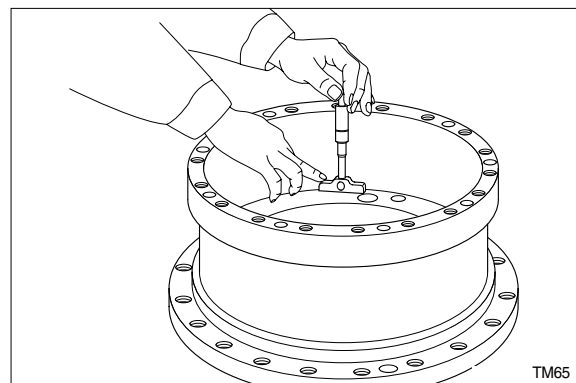

## C: THICKNESS SELECTION OF A THRUST BEARING (20)

- (1) If the parts listed below have been replaced, select a thrust bearing (20) of the appropriate thickness.

After selection, return to the original reassembling procedure [procedure (15) at page 8-113] and carry out the next step of that procedure.

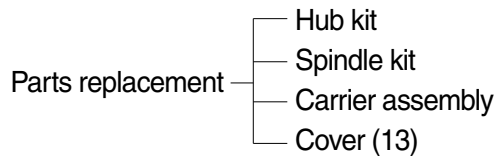

- (2) Steps (1) through (4) of the original reassembling procedure must be carried out as directed.

- ① Attach one of the two thrust bearings (20) to the coupling gear (8).

At this time, use the thinnest distance piece.

- ② Mount the coupling (19) on the shaft (102).

- ③ Place the sun gear (7) in the coupling (19).

- ④ Insert the carrier assembly into the hub (1), and correctly engage the teeth of ring gear B (5) and teeth B of the cluster gear (6).

※ This must be done only after determining the timing point of carrier assembly reassembling (see next for further details.)

※ Do not apply molybdenum disulfide grease to the thrust bearing (20).

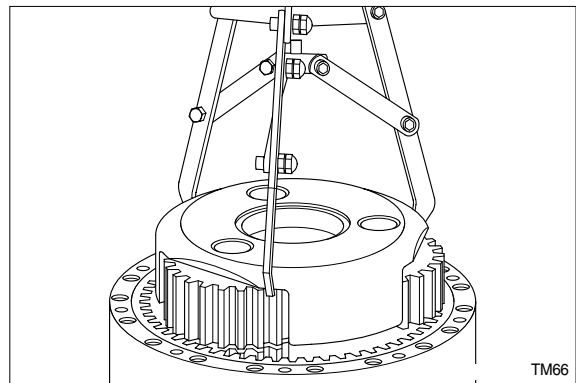

- ⑤ Fit the match marks on ring gear A (4) and the hub (1), and mount the ring gear on the hub. Check at this time that teeth A of the cluster gear (6) and the teeth of ring gear A (4) are in correct engagement.

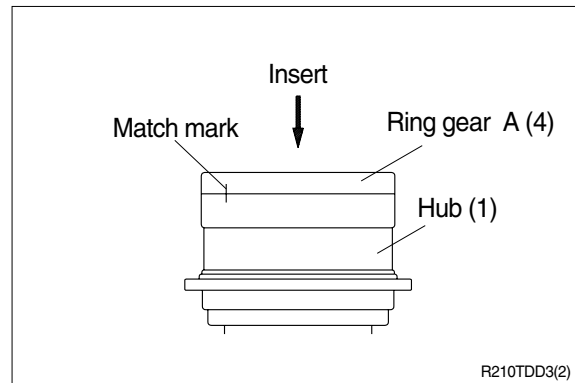

- ⑥ Mount a thrust-bearing adjusting plate on the hub (1), and lightly tighten the former using two M12 hexagon socket bolts.

※ Do not mount the thrust bearing (20) at this time.

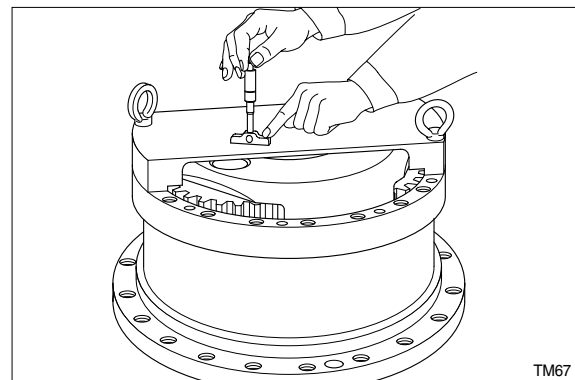

- ⑦ As shown in the figure at right, measure dimension **A** using a depth micrometer.

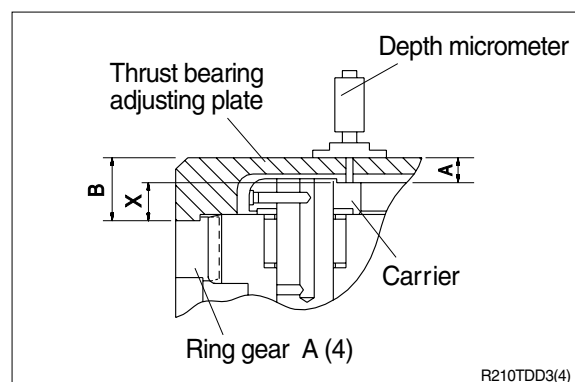

- ⑧ Measure dimension **C** of the cover (13) to be mounted. See the figure at right.

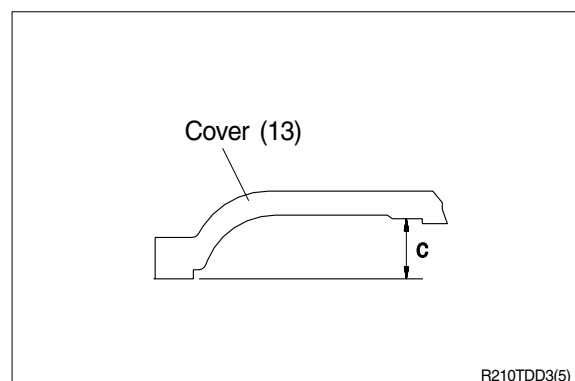

- ⑨ Using the clearance measurements, calculate the appropriate thrust bearing thickness as follows.
- Measure the clearance between the edge of the carrier (3) and that of ring gear A (4).  
Take this clearance as **X**  
**X = B - A**  
**A** : Dimension required  
**B** : Jig dimension
  - Next, determine the thrust bearing of the appropriate thickness.  
Take this thickness as **T**.  
**T = (C - X) - (0.3 to 0.6)**
- ⑩ Using the results of steps (7) through (9) above, select the appropriate thickness from three types.  
Then, proceed with the original reassembling operation.