

GROUP 3 TRACK AND WORK EQUIPMENT

1. TRACK

1) TRACK ROLLER

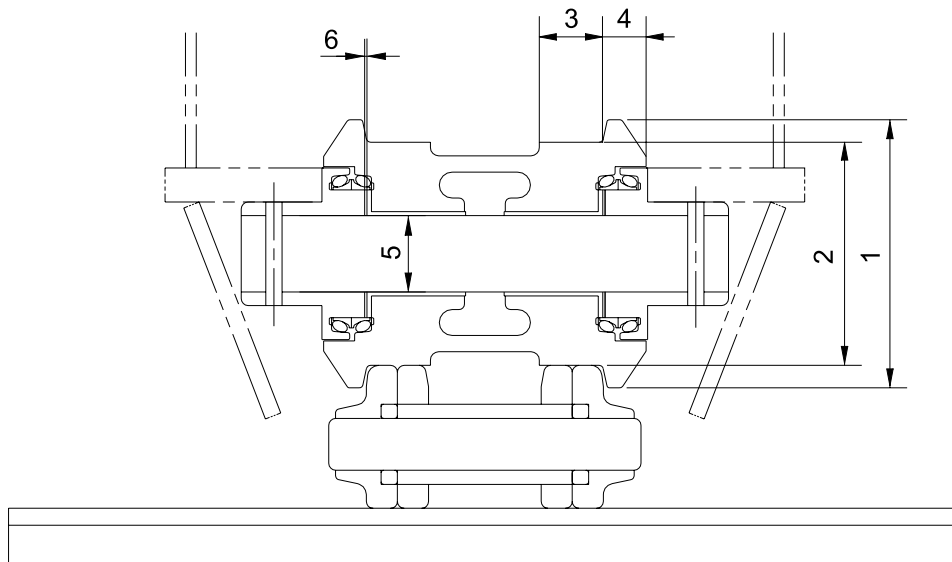

32077MS01

Unit : mm

No.	Check item	Criteria				Remedy
		Standard size		Repair limit		
1	Outside diameter of flange	ø 200		-		Rebuild or replace
2	Outside diameter of tread	ø 160		ø 148		
3	Width of tread	48		54		
4	Width of flange	21.5		-		
5	Clearance between shaft and bushing	Standard size & Tolerance		Standard clearance	Clearance limit	Replace bushing
		Shaft	Hole			
		ø 70 -0.29 -0.33	ø 70.1 +0.46 0	0.39 to 0.476	2.0	
6	Side clearance of roller (Both side)	Standard clearance		Clearance limit		Replace
		0.2 to 1.2		2.0		

2) CARRIER ROLLER

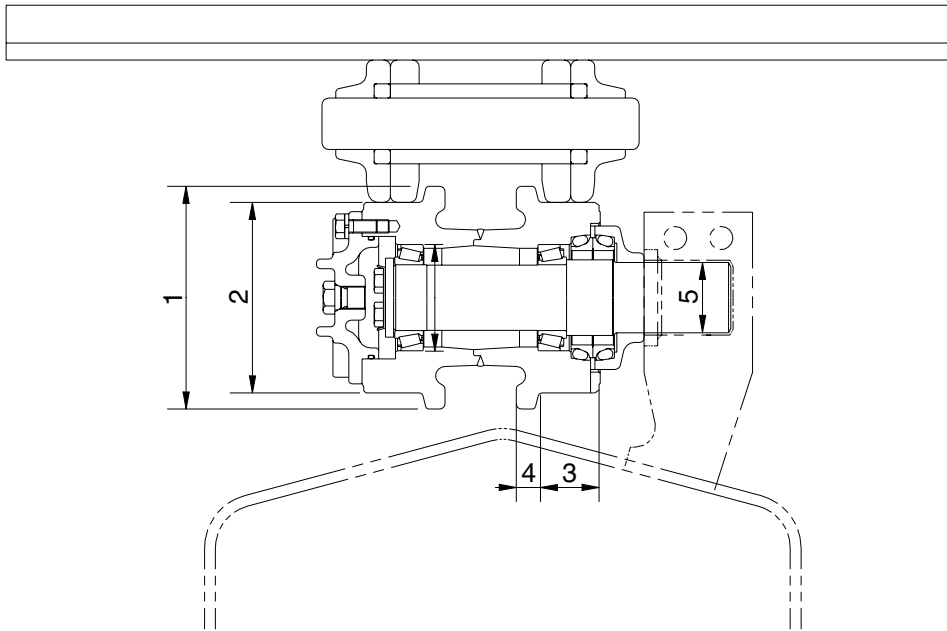

16077MS02

Unit : mm

No.	Check item	Criteria				Remedy
		Standard size		Repair limit		
1	Outside diameter of flange	ø 169		ø 155		Rebuild or replace
2	Outside diameter of tread	ø 144		ø 134		
3	Width of tread	44		49		
4	Width of flange	17		-		
5	Clearance between shaft and support	Standard size & Tolerance		Standard clearance	Clearance limit	Replace
		Shaft	Hole			
		ø 55 -0.05 -0.1	ø 55 +0.3 +0.1	0.15 to 0.4	1.2	

3) IDLER

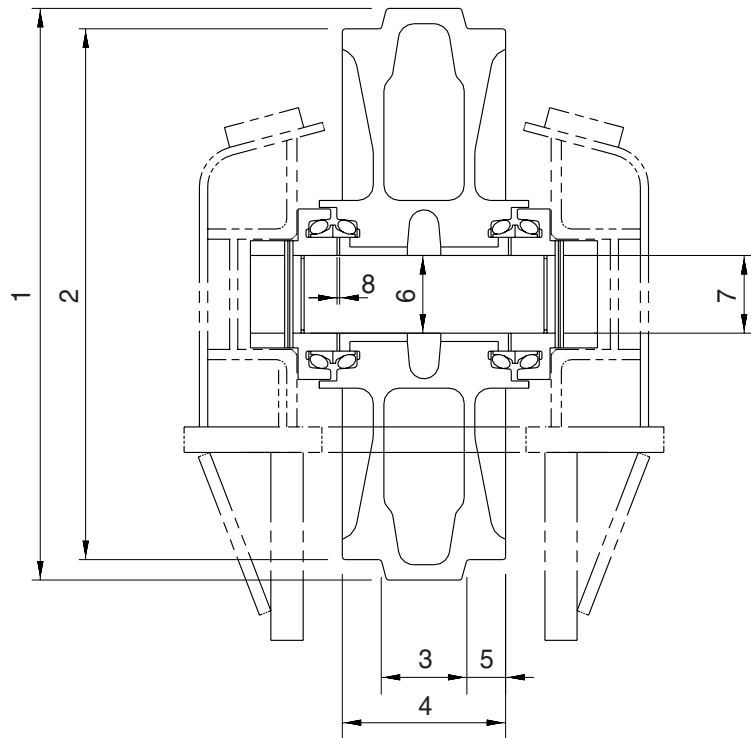

21037MS03

Unit : mm

No.	Check item	Criteria		Remedy		
		Standard size	Repair limit			
1	Outside diameter of protrusion	$\phi 560$	-	Rebuild or replace		
2	Outside diameter of tread	$\phi 520$	$\phi 510$			
3	Width of protrusion	84	-			
4	Total width	160	-			
5	Width of tread	38	43			
6	Clearance between shaft and bushing	Standard size & Tolerance		Standard clearance	Clearance limit	Replace bushing
		Shaft	Hole			
		$\phi 75 \begin{matrix} 0 \\ -0.03 \end{matrix}$	$\phi 75.35 \begin{matrix} +0.05 \\ 0 \end{matrix}$	0.35 to 0.43	2.0	
7	Clearance between shaft and support	$\phi 75 \begin{matrix} 0 \\ -0.03 \end{matrix}$	$\phi 75 \begin{matrix} +0.07 \\ +0.03 \end{matrix}$	0.03 to 0.1	1.2	Replace
8	Side clearance of idler (Both side)	Standard clearance		Clearance limit		Replace
		0.25 to 1.2		2.0		

4) TRACK

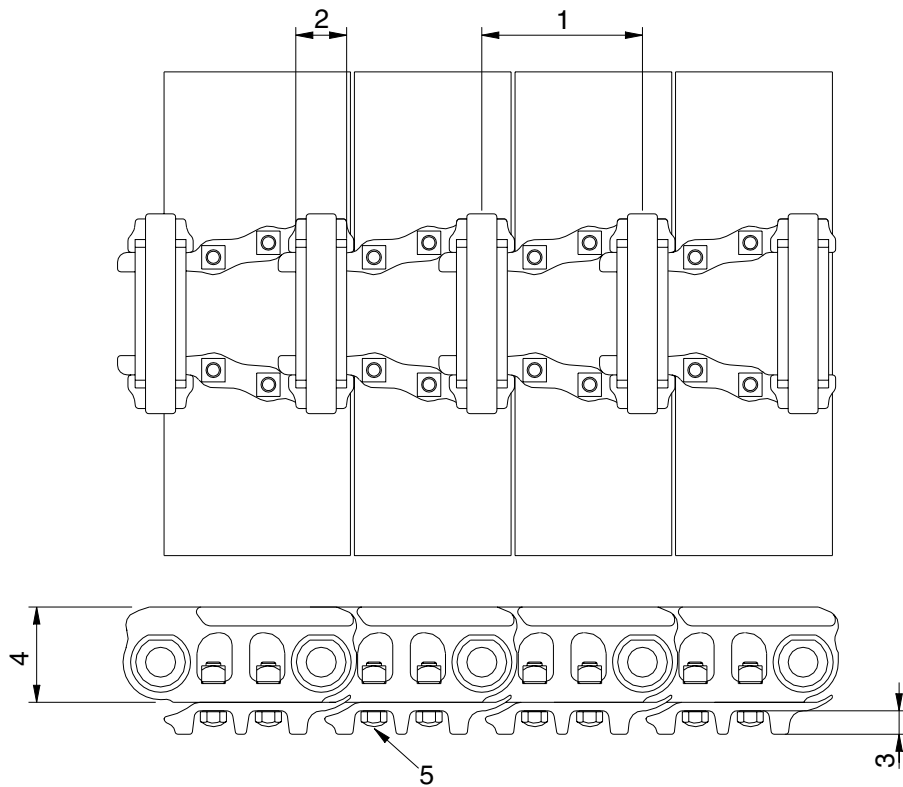

32077MS04

Unit : mm

No.	Check item	Criteria		Remedy
		Standard size	Repair limit	
1	Link pitch	171.45	175.65	Turn or replace
2	Outside diameter of bushing	∅ 54	∅ 46	
3	Height of grouser	25	16	Rebuild or replace
4	Height of link	101.6	93.6	
5	Tightening torque	Initial tightening torque : $40 \pm 4 \text{kgf} \cdot \text{m}$		Retighten

5) TRACK FRAME AND RECOIL SPRING

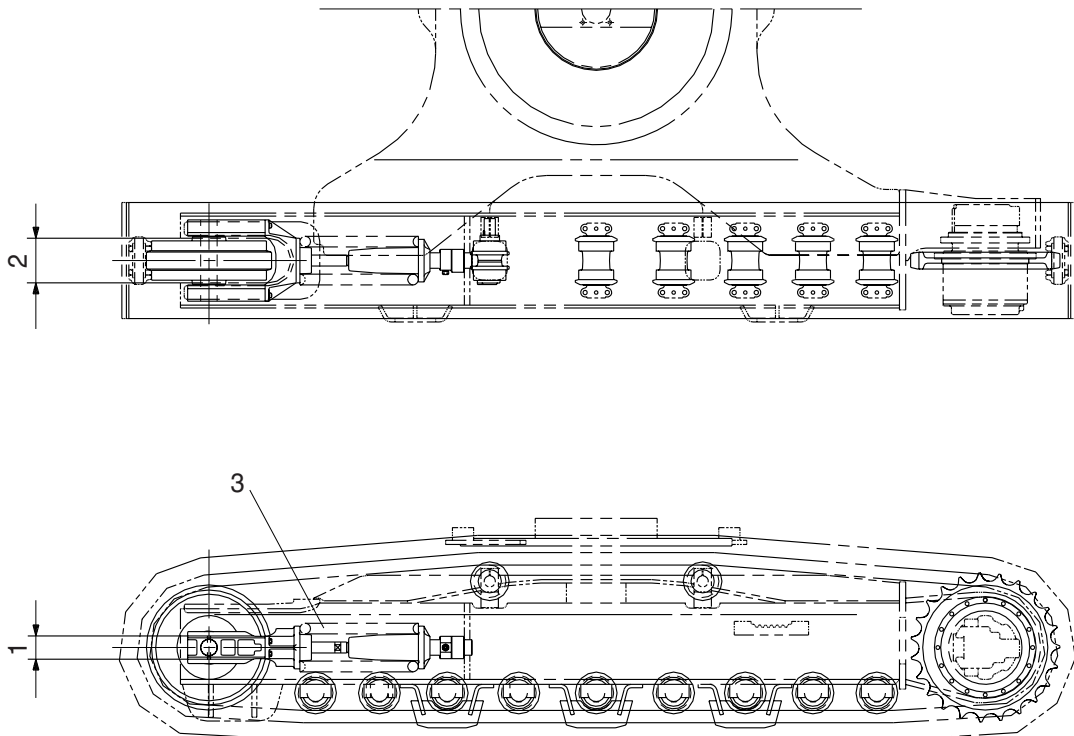

21037MS05

Unit : mm

No.	Check item	Criteria				Remedy	
			Standard size	Tolerance	Repair limit		
1	Vertical width of idler guide	Track frame	113	+2 0	117	Rebuild or replace	
		Idler support	110	-0.5 -1.0	106		
2	Horizontal width of idler guide	Track frame	272	+2 0	276		
		Idler support	270	-	267		
3	Recoil spring	Standard size			Repair limit		Replace
		Free length	Installation length	Installation load	Free length	Installation load	
		∅ 225 × 552	420	11,908kg	-	9,526kg	

2. WORK EQUIPMENT

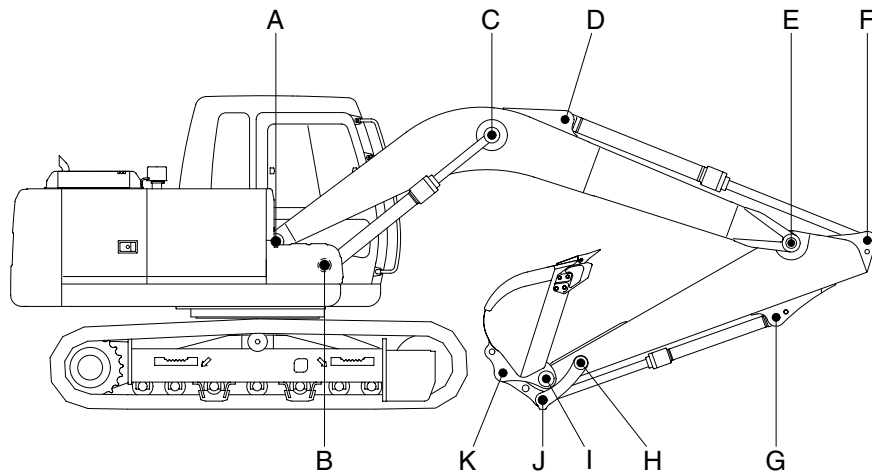

160LC7MS20

Unit : mm

Mark	Measuring point (Pin and Bushing)	Normal value	Pin		Bushing		Remedy & Remark
			Recomm. service limit	Limit of use	Recomm. service limit	Limit of use	
A	Boom Rear	75	74	73.5	75.5	76	Replace
B	Boom Cylinder Head	70	69	68.5	70.5	71	"
C	Boom Cylinder Rod	75	74	73.5	75.5	76	"
D	Arm Cylinder Head	70	69	68.5	70.5	71	"
E	Boom Front	75	74	73.5	75.5	76	"
F	Arm Cylinder Rod	70	69	68.5	70.5	71	"
G	Bucket Cylinder Head	70	69	68.5	70.5	71	"
H	Arm Link	70	69	68.5	70.5	71	"
I	Bucket and Arm Link	70	69	68.5	70.5	71	"
J	Bucket Cylinder Rod	70	69	68.5	70.5	71	"
K	Bucket Link	70	69	68.5	70.5	71	"