

GROUP 2 ENGINE SYSTEM

1. ENGINE AND ACCESSORIES MOUNTING

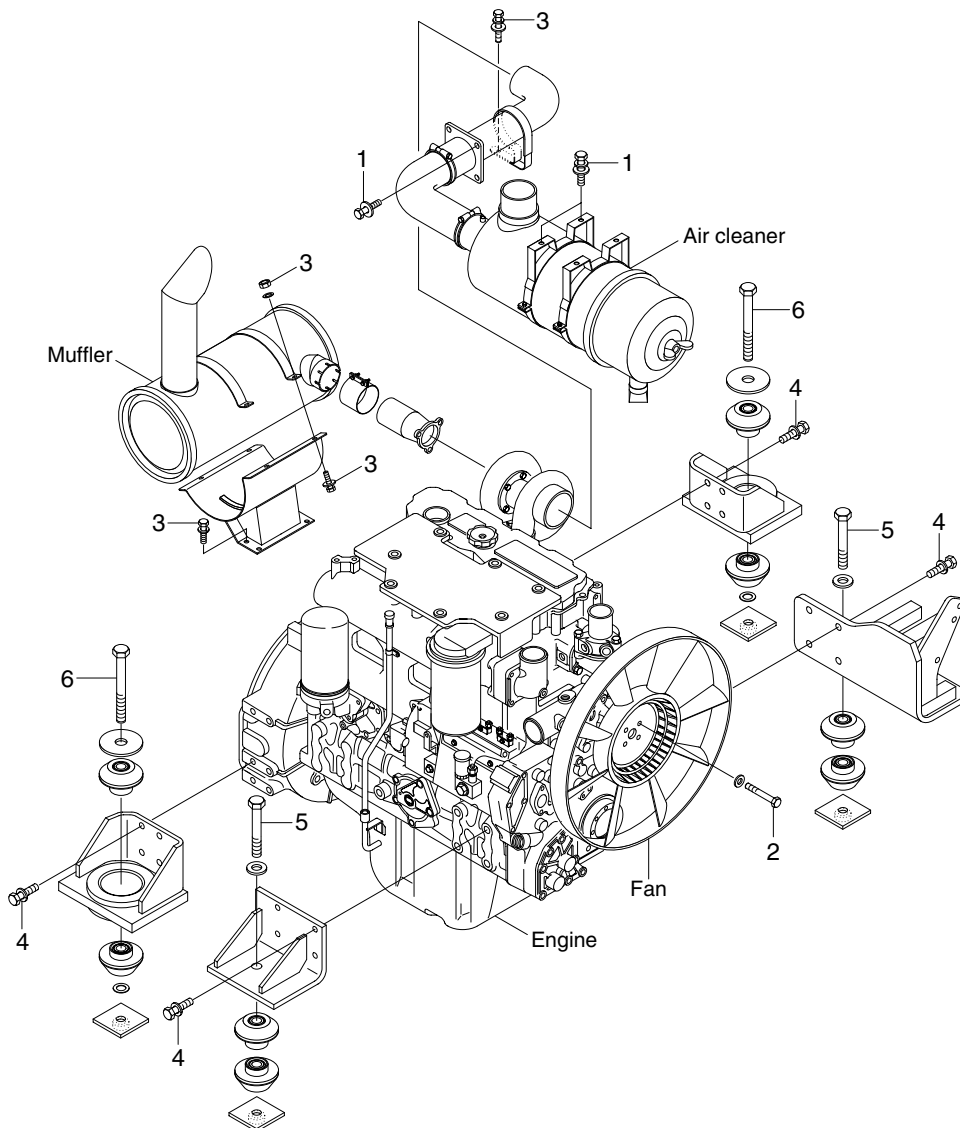

1607A9CM01

· Tightening torque

Item	Size	kgf · m	lbf · ft
1	M 8×1.25	2.5±0.5	18.1±3.6
2	M10×1.5	4.4±0.9	31.8±6.5
3	M10×1.5	6.9±1.4	49.9±10.1

Item	Size	kgf · m	lbf · ft
4	M12×1.75	10.0±1.0	72.3±7.2
5	M16×2.0	30.0±3.5	217±25.3
6	M20×2.5	55±3.5	398±25.3

2. COOLING SYSTEM AND FUEL TANK MOUNTING

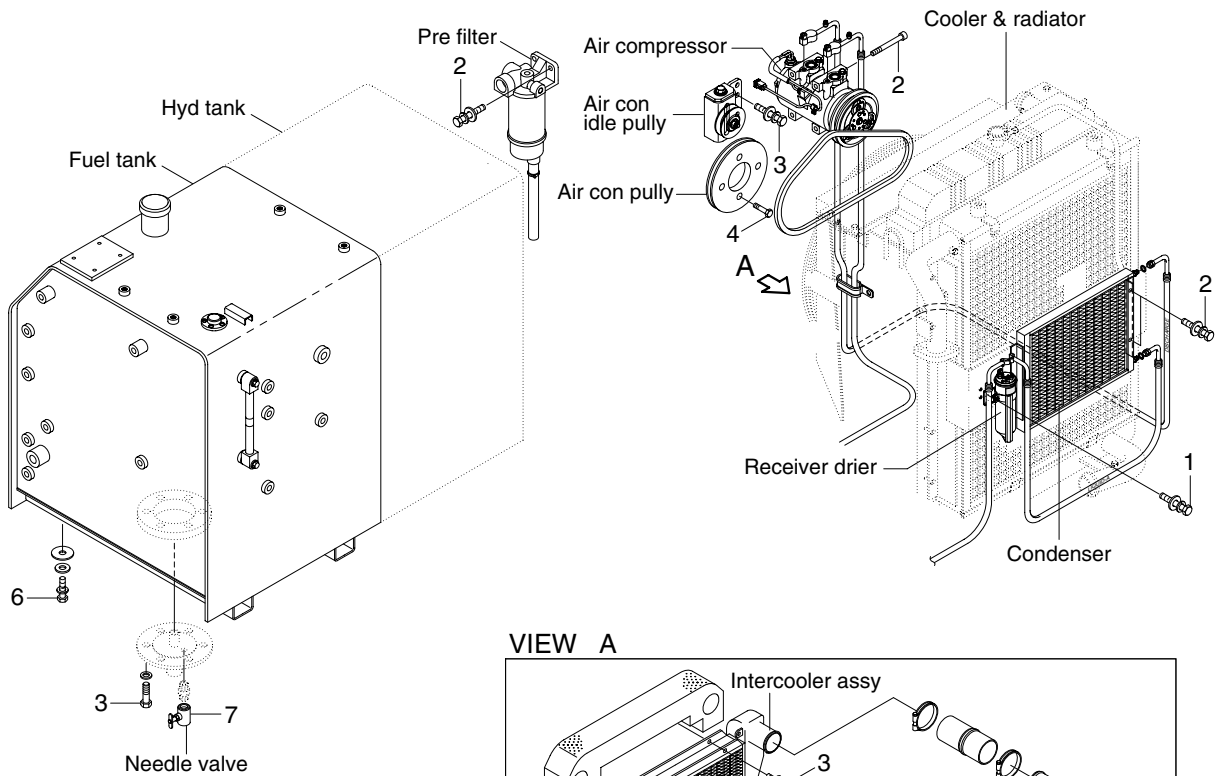

VIEW A

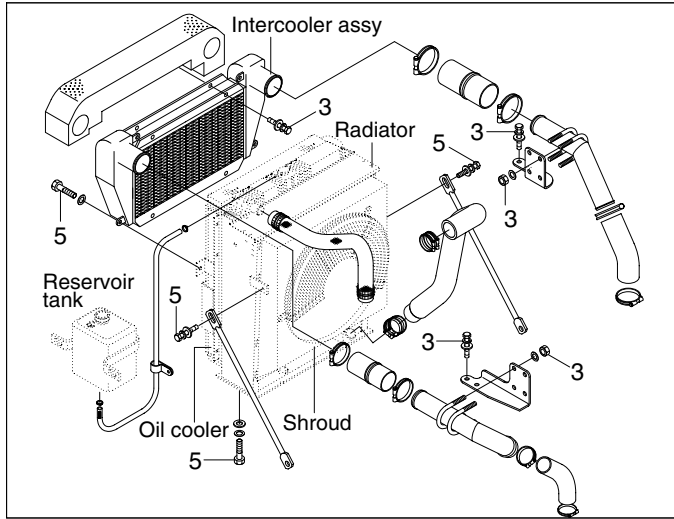

1607A9CM02

· Tightening torque

Item	Size	kgf · m	lbf · ft
1	M 6×1.0	1.05±0.2	7.6±1.45
2	M 8×1.25	2.5±0.5	18.1±3.6
3	M10×1.5	6.9±1.4	49.9±10.1
4	M10×1.5	8.27±1.7	59.8±12.3

Item	Size	kgf · m	lbf · ft
5	M12×1.75	12.8±3.0	92.6±21.7
6	M20×2.5	45±5.1	325±36.9
7	-	2.3±0.6	16.6±4.3
-	-	-	-