

## SECTION 4 ELECTRICAL SYSTEM

Group 1 Component Location .....	4-1
Group 2 Electrical Circuit .....	4-3
Group 3 Electrical Component Specification .....	4-20
Group 4 Connectors .....	4-29

# SECTION 4 ELECTRICAL SYSTEM

## GROUP 1 COMPONENT LOCATION

### 1. LOCATION 1

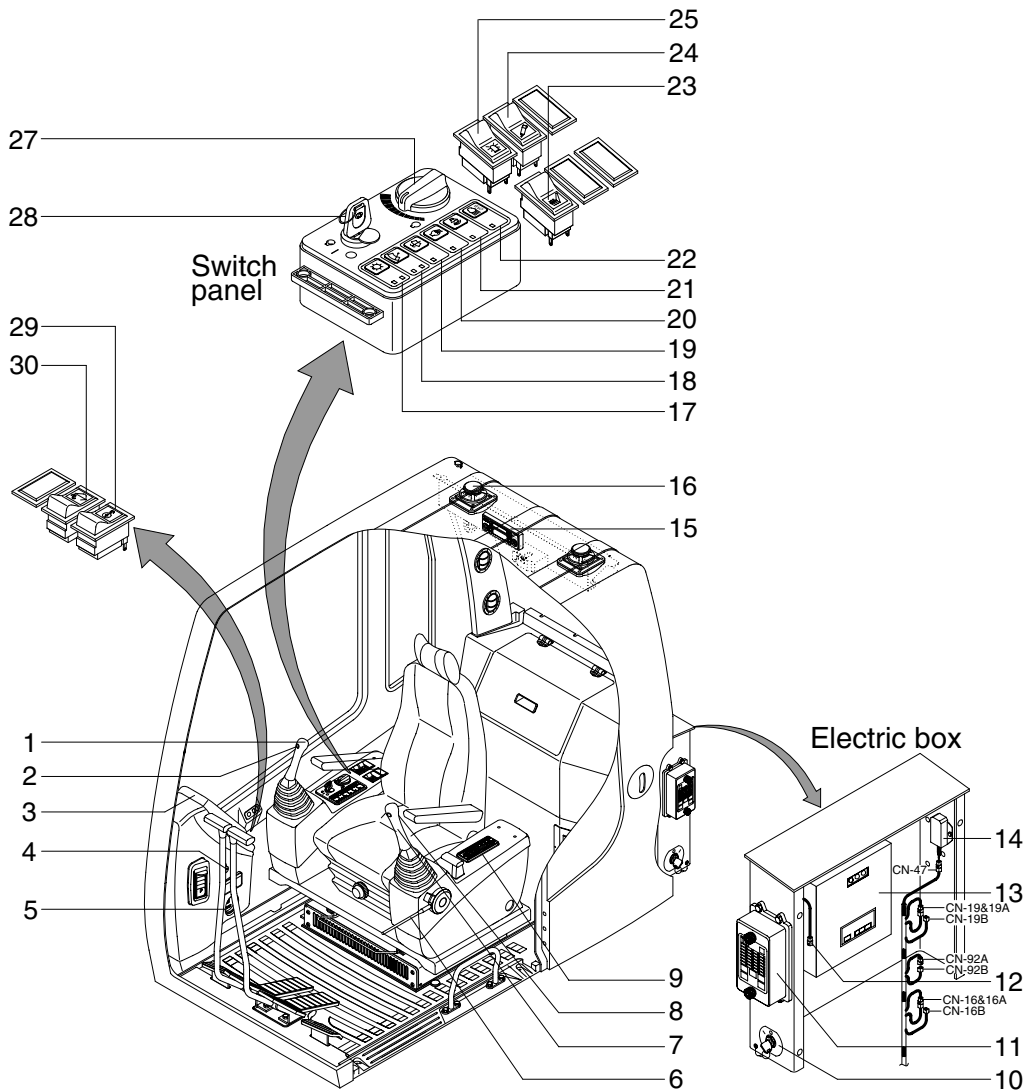

1607A4EL01

- |    |                          |    |                        |    |                          |
|----|--------------------------|----|------------------------|----|--------------------------|
| 1  | Horn switch              | 11 | Fuse box               | 21 | Preheat switch           |
| 2  | Breaker operation switch | 12 | RS232 serial connector | 22 | Travel alarm switch      |
| 3  | Cluster                  | 13 | J1939 serial connector | 23 | Cab light switch         |
| 4  | Cigar lighter            | 14 | Machine control unit   | 24 | Heated seat switch       |
| 5  | Hour meter               | 15 | Prolix resistor        | 25 | Breaker selection switch |
| 6  | Safety lever             | 16 | Cassette radio         | 26 | Beacon switch            |
| 7  | Power max switch         | 17 | Speaker                | 27 | Accel dial               |
| 8  | One touch decel switch   | 18 | Main light switch      | 28 | Start switch             |
| 9  | Air conditioner switch   | 19 | Wiper switch           | 29 | Overload switch          |
| 10 | Master switch            | 20 | Washer switch          | 30 | Quick clamp switch       |

## 2. LOCATION 2

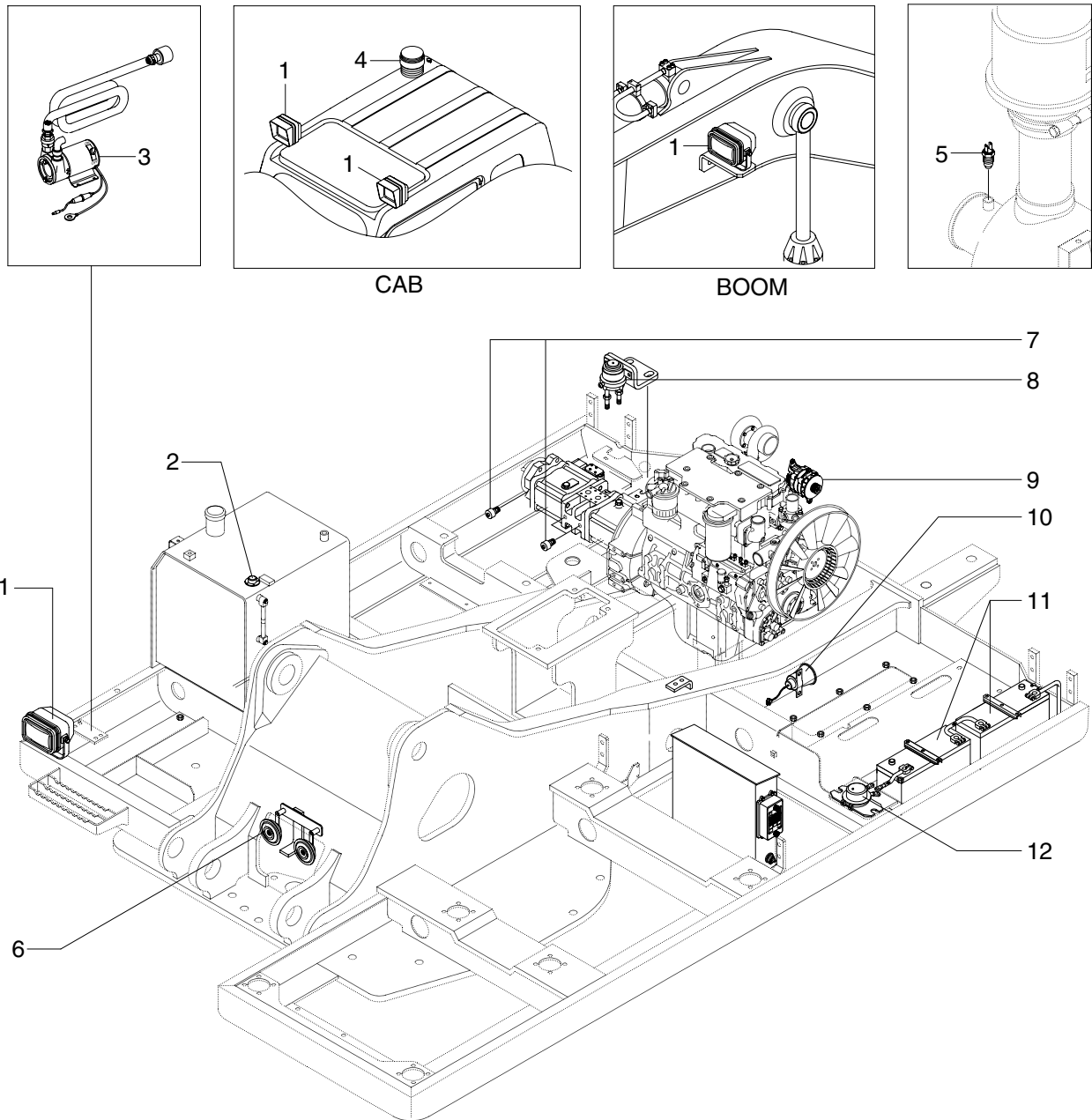

1607A4EL02

- |   |                    |    |                     |
|---|--------------------|----|---------------------|
| 1 | Lamp               | 7  | Pressure sender     |
| 2 | Fuel sender        | 8  | Heater relay        |
| 3 | Fuel filler pump   | 9  | Alternator          |
| 4 | Beacon lamp        | 10 | Travel alarm buzzer |
| 5 | Air cleaner switch | 11 | Battery             |
| 6 | Horn               | 12 | Battery relay       |