

# GROUP 4 MECHATRONICS SYSTEM

## 1. ALL ACTUATORS SPEED ARE SLOW

Boom, Arm, Bucket, Swing and travel speed are slow, but engine speed is good.

Spec : M-mode 2200 ± 50rpm H-mode 2000 ± 50rpm S-mode 1900 ± 50rpm

Before carrying out below procedure, check all the related connectors are properly inserted.

### 1) INSPECTION PROCEDURE

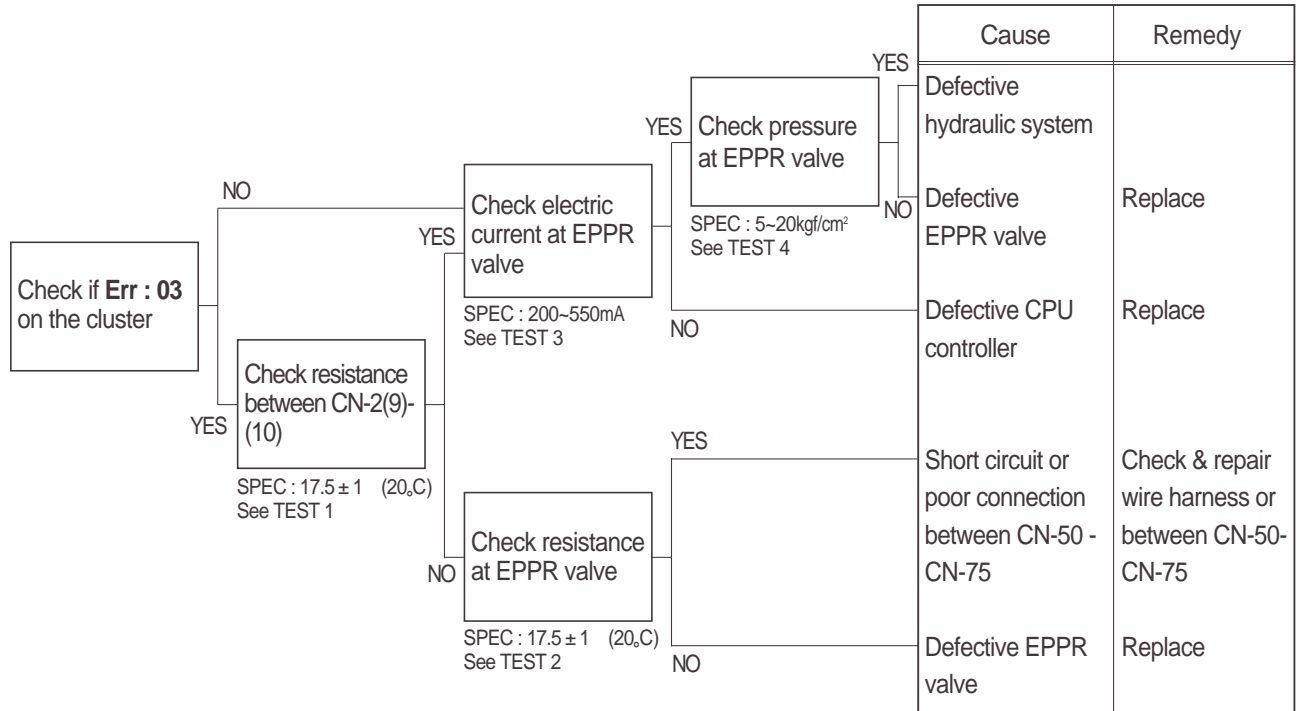

### Wiring diagram

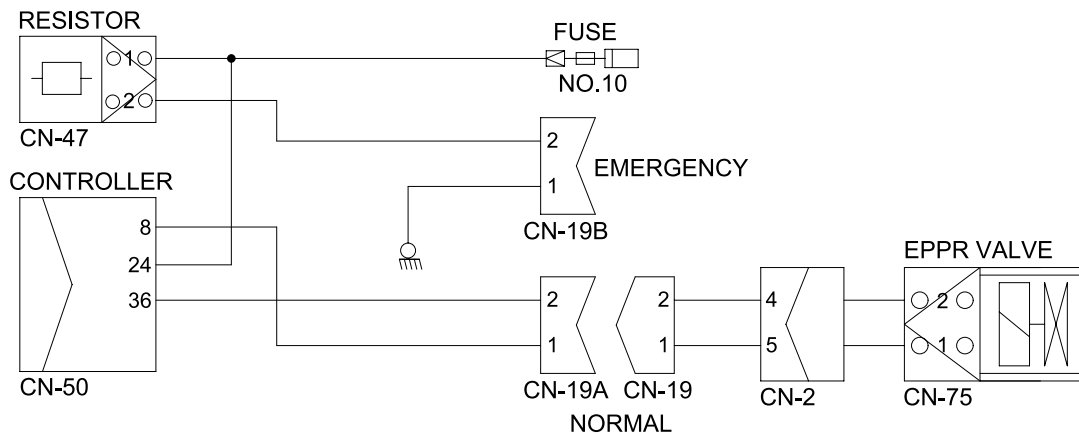

16075MS30

## 2) TEST PROCEDURE

- (1) **Test 1** : Check resistance at connector CN-2(9)-(10).

Starting key OFF.

Disconnect connector CN-2.

Check resistance between pin and at connector CN-2(9)-(10).

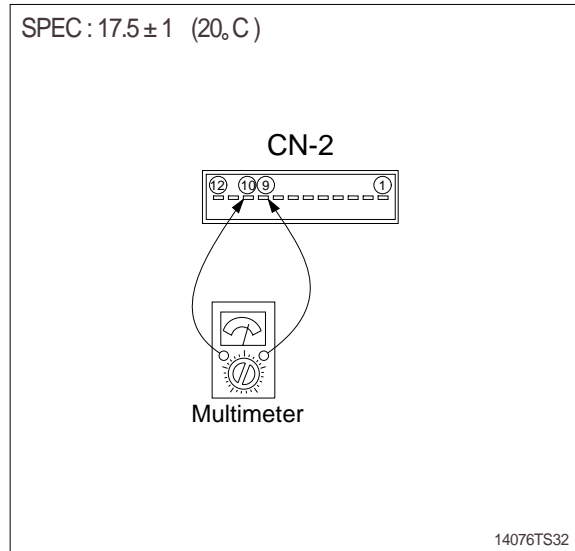

- (2) **Test 2** : Check resistance at connector CN-75.

Starting key OFF.

Disconnect connector CN-75 from EPPR valve at main hydraulic pump.

Check resistance between 2 lines as figure.

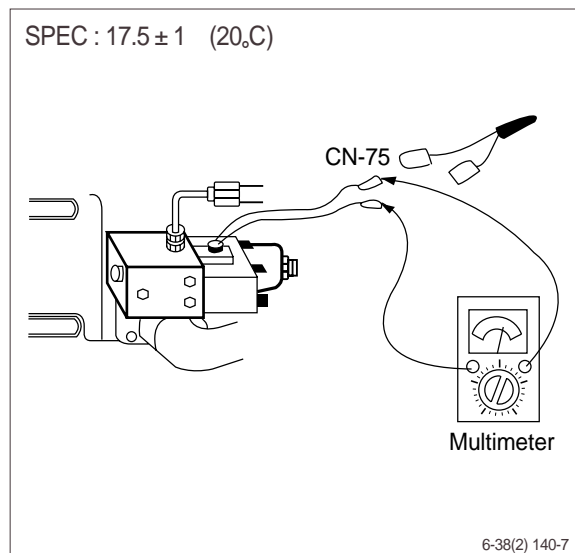

- (3) **Test 3** : Check electric current at EPPR valve.

Install multimeter as figure.

Start engine.

Set the accel dial at "10"(MAX)

Set S-mode and cancel auto decel mode.

If tachometer show approx  $1900 \pm 50$ rpm, check electric current.

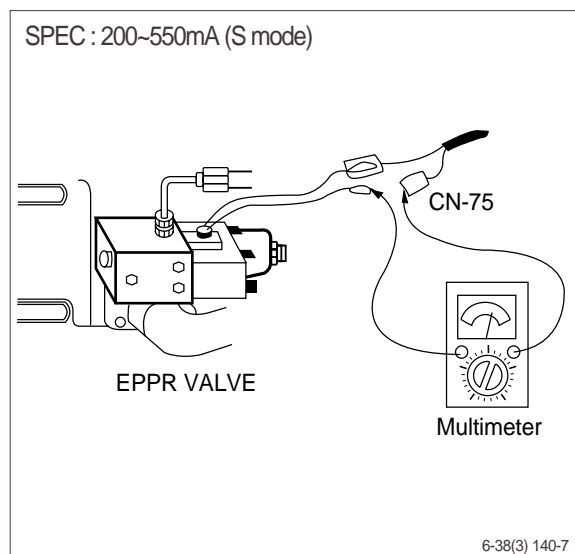

(2) **Test 4** : Check pressure at EPPR valve.  
Remove plug and connect pressure gauge as figure.

- Gauge capacity : 0 to 40~50kgf/cm<sup>2</sup>  
(0 to 570~710psi)

Start engine.

Set the accel dial at "10"(Max)

Set S-mode and cancel auto decel mode.

If tachometer show approx 1900±50rpm,  
check pressure.

If pressure is not correct, adjust it.

After adjust, test the machine.

SPEC : 5~20kgf/cm<sup>2</sup>(70~280psi)

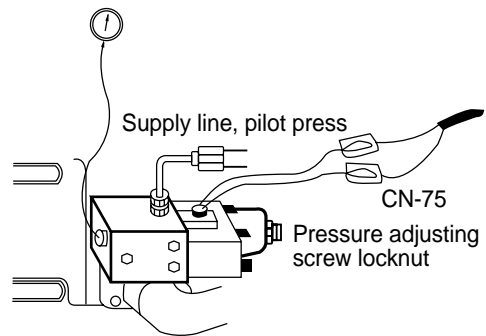

6-39(1) 140-7

## 2. ENGINE SPEED IS SLOW AT ALL MODE

Before carrying out below procedure, check all the related connectors are properly inserted.

### 1) INSPECTION PROCEDURE

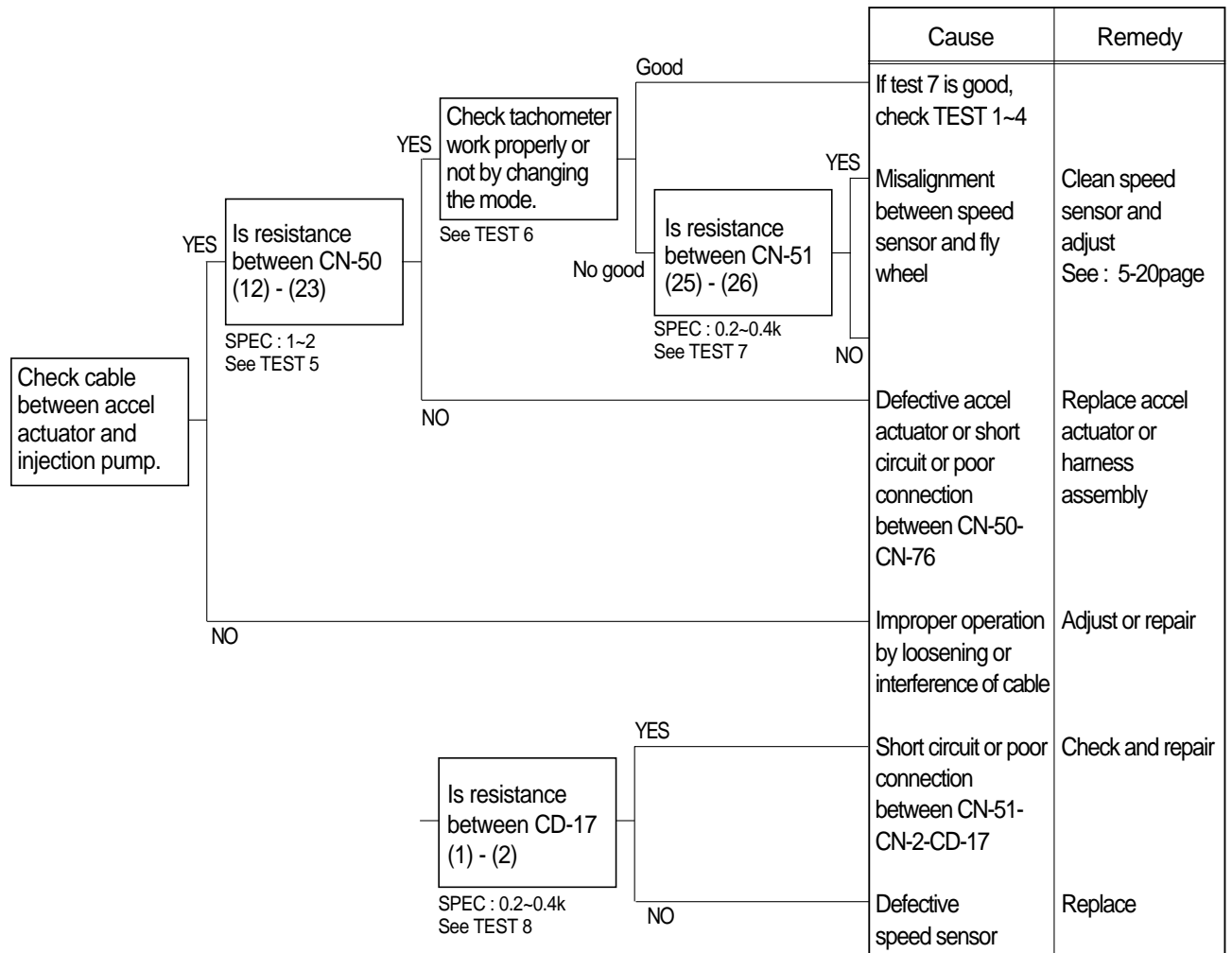

### Wiring diagram

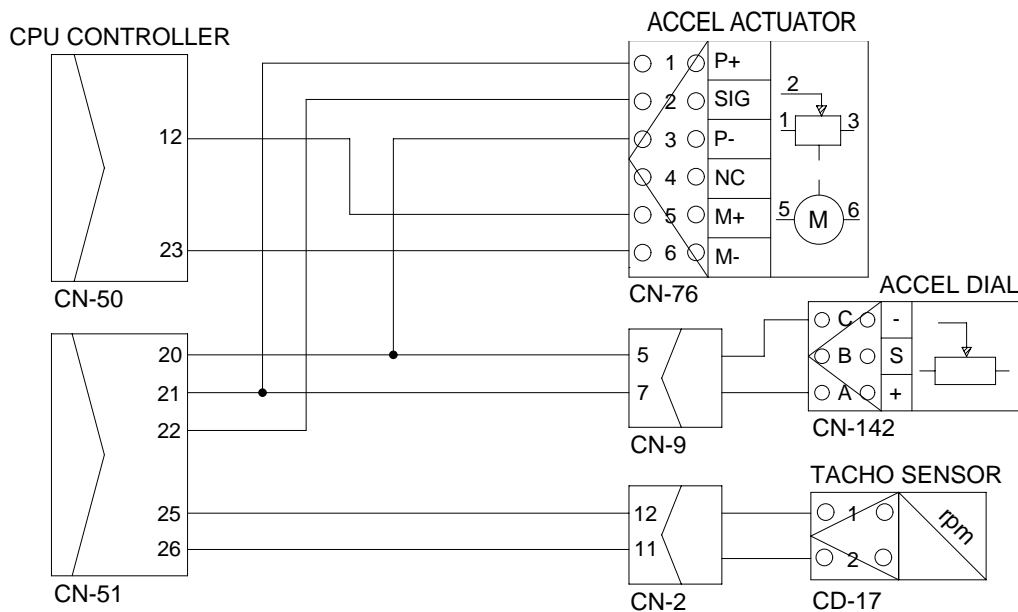

R29076MS03

## 2) TEST PROCEDURE

- (1) **Test 5** : Check resistance between CN-50 (12)-(23).

Starting key OFF.

Disconnect connector CN-50 from CPU controller.

Check resistance as figure.

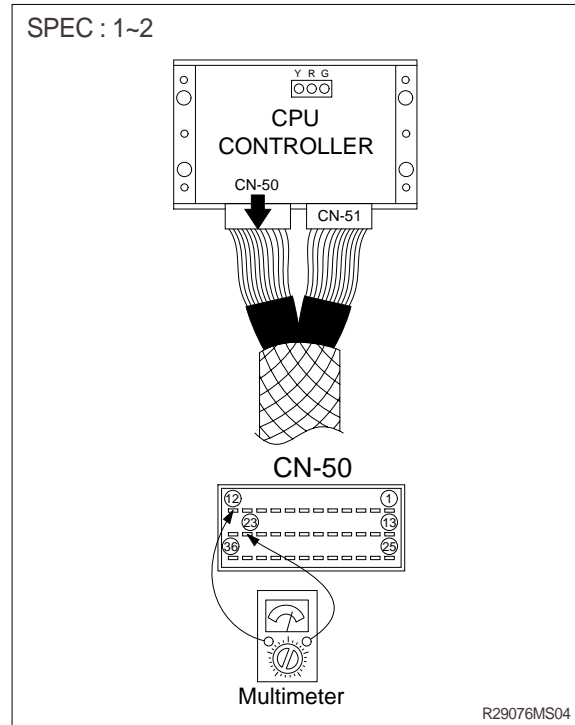

- (2) **Test 6** : Check tachometer(Work properly or not)

Start engine.

Check tachometer reading.

Unit : rpm

Spec		Remark
H-mode	2000 ± 50	Check rpm after cancel the Auto decel mode.
S-mode	1900 ± 50	

- (3) **Test 7** : Check resistance between CN-51 (25) and CN-51(26).

Starting key OFF.

Disconnect connector CN-51 from CPU controller.

Check resistance as figure.

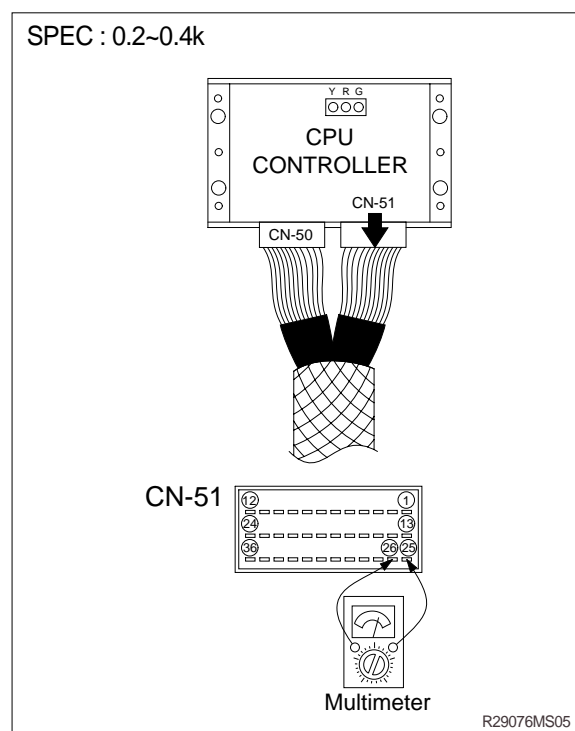

(4) **Test 8** : Check resistance at speed sensor.

Starting key OFF.

Disconnect connector CD-17 of speed sensor at engine flywheel housing.

Check resistance as figure.

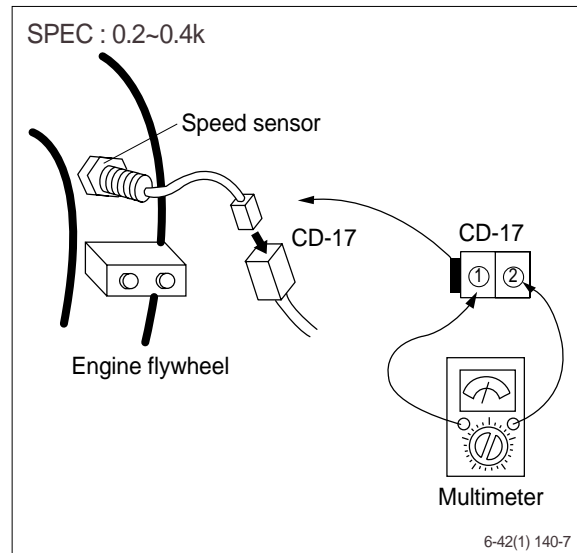

### 3. ENGINE STALL

Before carrying out below procedure, check all the related connectors are properly inserted.

#### 1) INSPECTION PROCEDURE

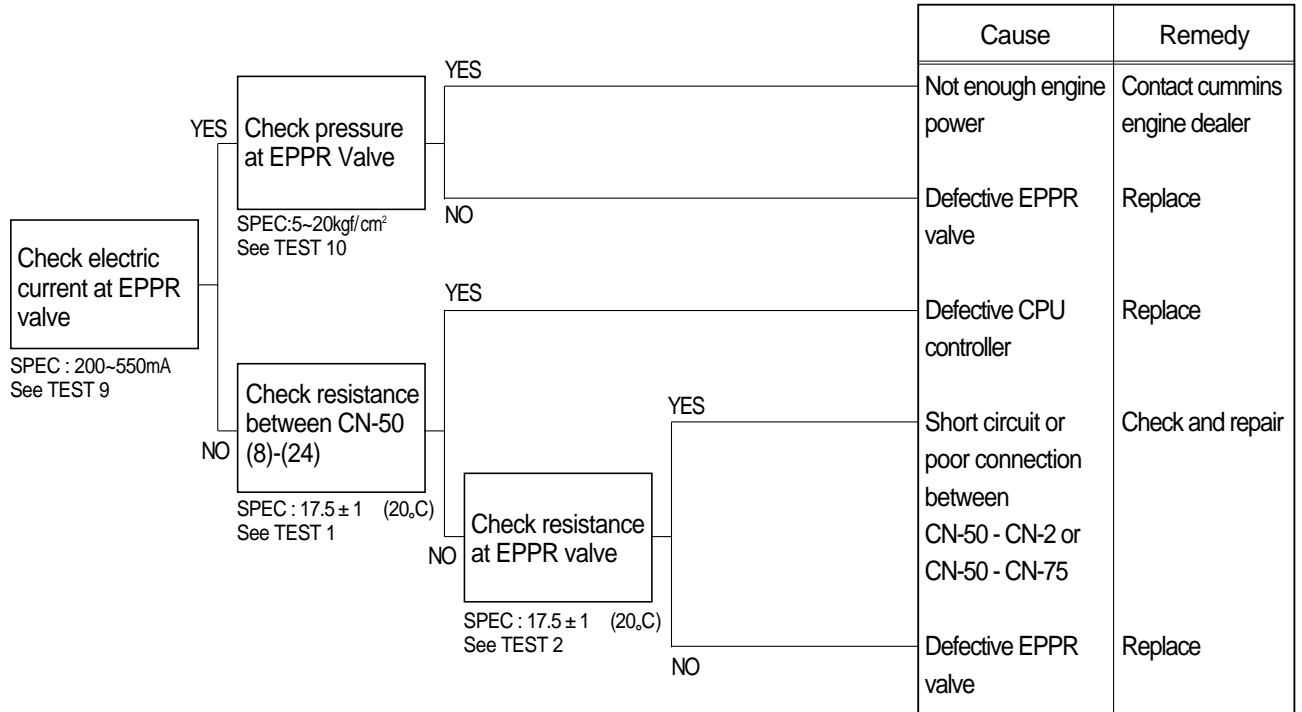

#### Wiring diagram

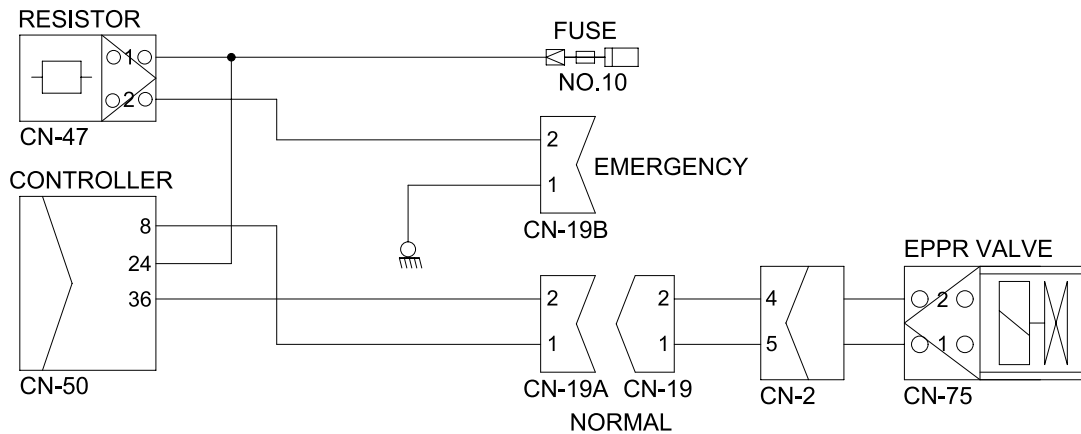

16075MS30

## 2) TEST PROCEDURE

### (1) **Test 9** : Check electric current at EPPR valve at S-mode

Install multimeter as figure.

Start engine.

Set the accel dial at "10"(max)

Set S-mode with  $1900 \pm 50$ rpm.

Check electric current.

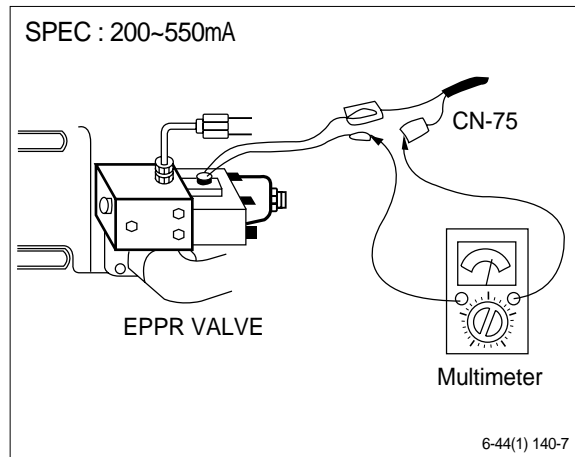

### (2) **Test 10** : Check pressure at EPPR valve at S-mode

Connect pressure gauge at EPPR valve.

Start engine.

Set the accel dial at "10"(max)

Set S-mode with  $1900 \pm 50$ rpm.

Operate bucket lever completely push or pull.

Hold arm lever at the end of stroke.

Check pressure at relief position.

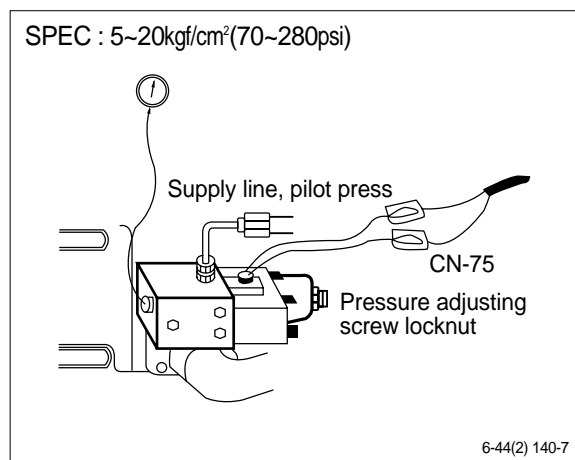



#### 4. MALFUNCTION OF CLUSTER OR MODE SELECTION SYSTEM

Before carrying out below procedure, check all the related connectors are properly inserted.

##### 1) INSPECTION PROCEDURE

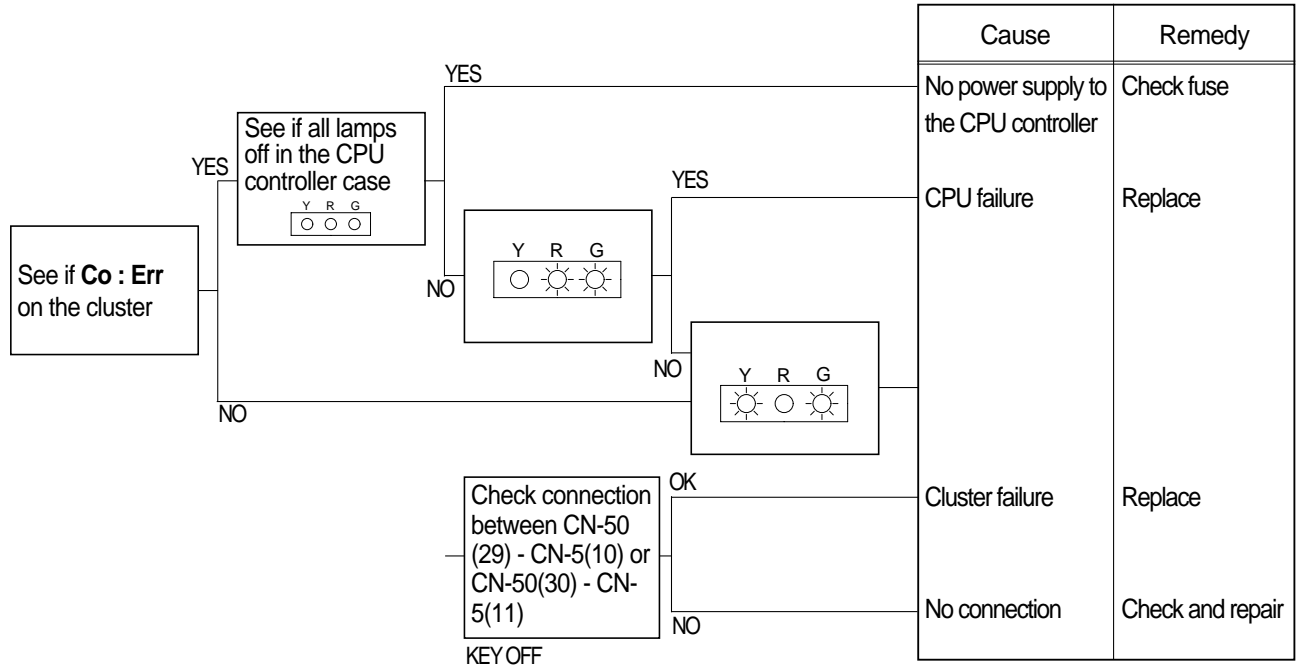

##### Wiring diagram

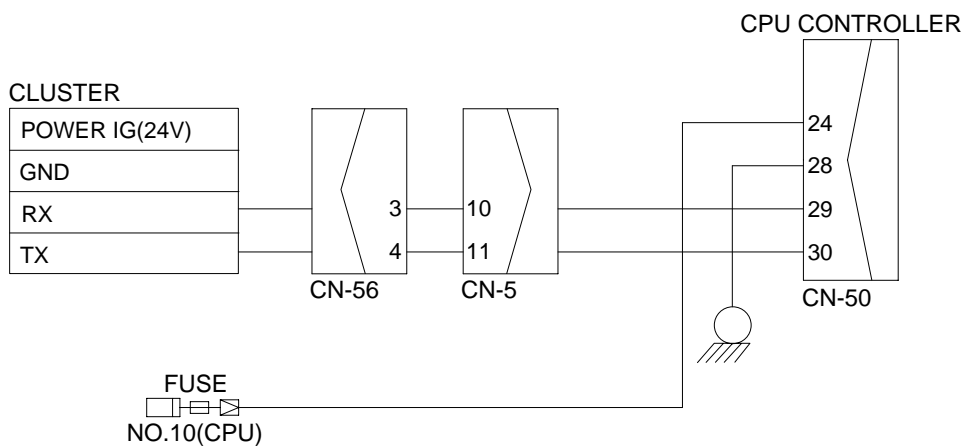

20W76MS03

## 5. SLOW ACTION OF ENGINE SPEED CHANGE WHEN CHANGE THE MODE

Before carrying out below procedure, check all the related connectors are properly inserted.

### 1) INSPECTION PROCEDURE

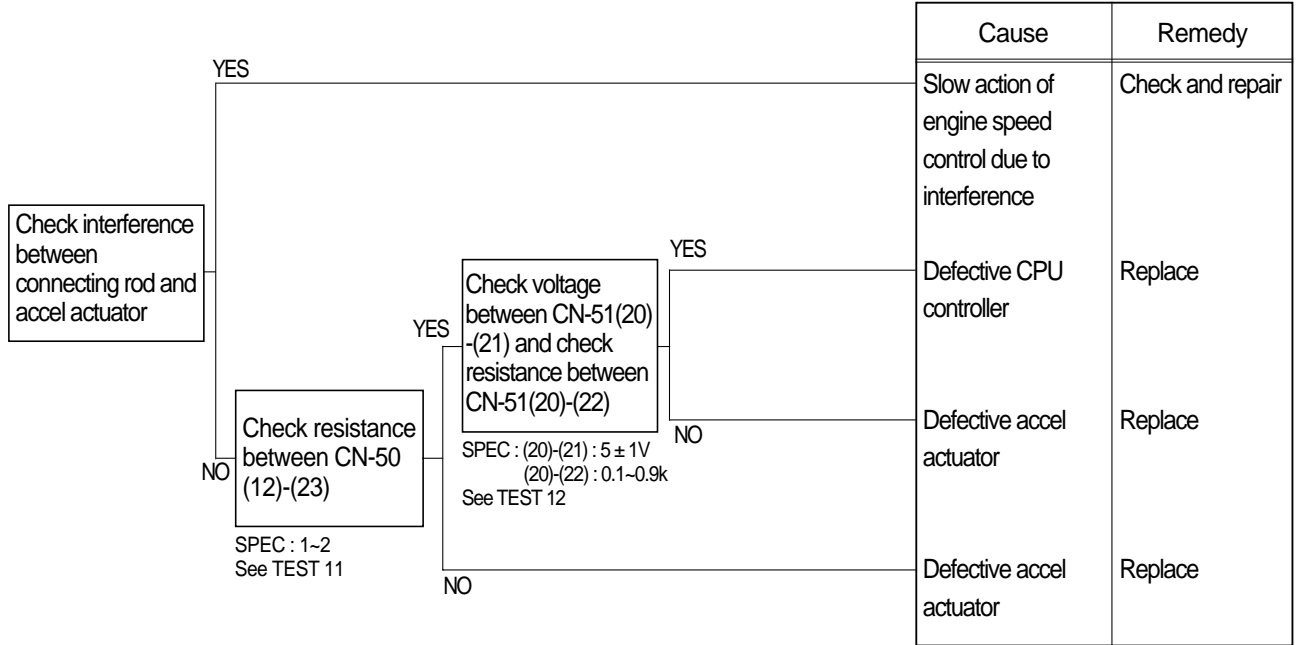

### Wiring diagram

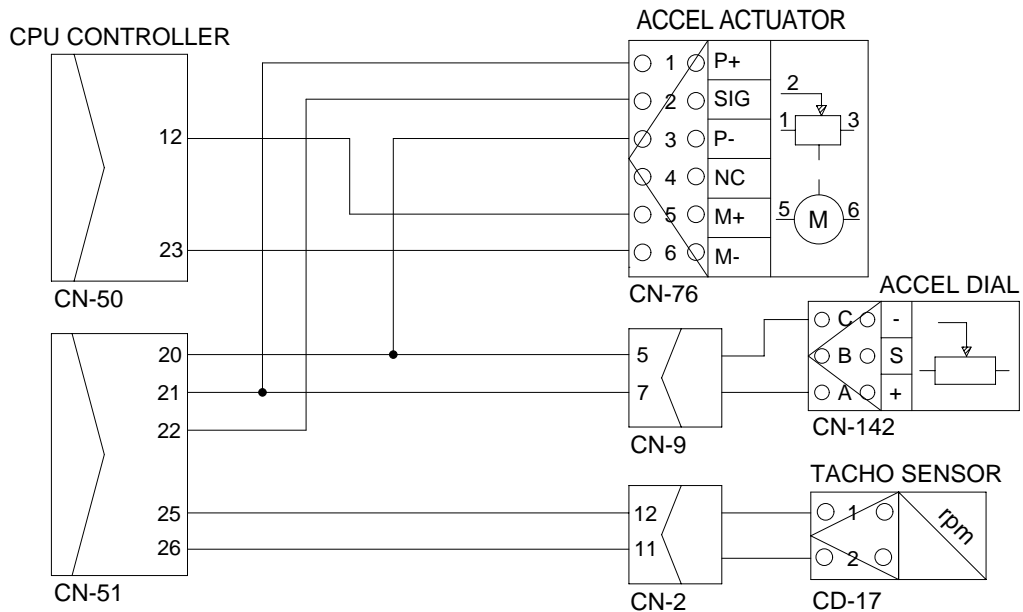

R29076MS03

## 2) TEST PROCEDURE

- (1) **Test 11** : Check resistance.  
Starting key OFF.  
Disconnect connector CN-50 from CPU controller.  
Check resistance between CN-50(12)-(23) as figure.

SPEC : 1~2

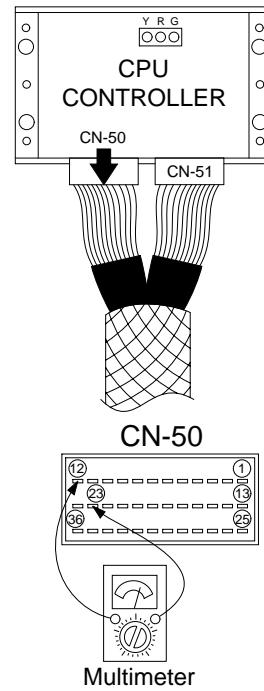

R29076MS04

- (2) **Test 12** : Check voltage and resistance.  
 Check resistance between CN-51(20)-  
 (22).
- Starting key OFF.
  - Disconnect connector CN-51 from CPU controller.
  - Check resistance value with multimeter as figure.

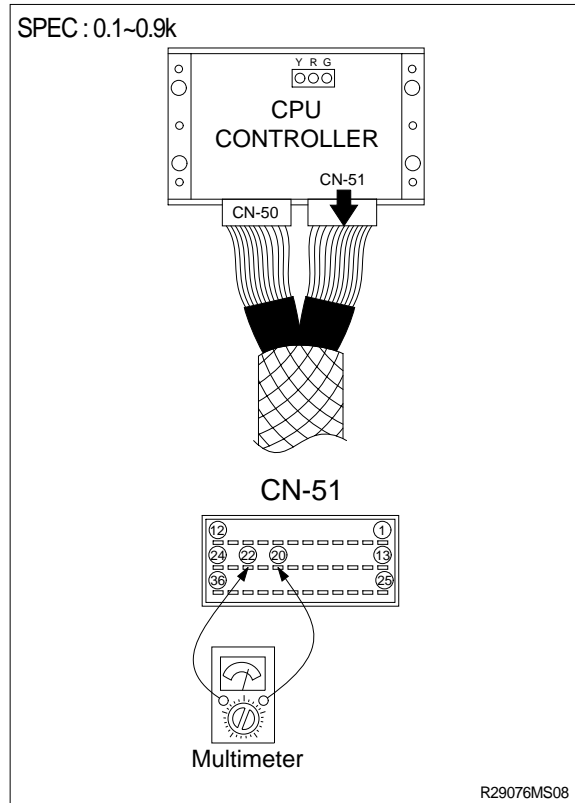

Check voltage between CN-51(20) and  
 CN-51(21).

- Prepare 2 pieces of thin sharp pin, steel or copper.
- Starting key ON.
- Insert prepared pins to rear side of connectors : One pin to CN-51(20)  
 Other pin to CN-51(21)
- Check voltage.

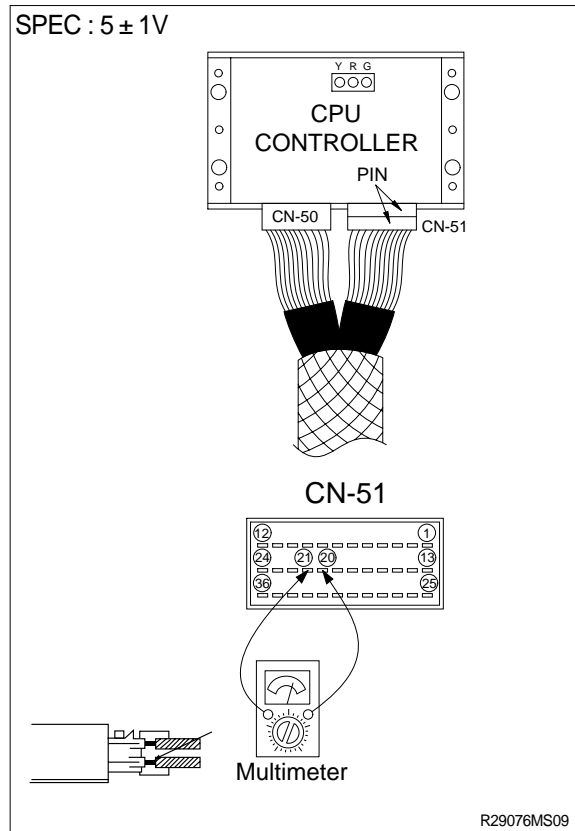

## 6. AUTO DECEL SYSTEM DOES NOT WORK

Before carrying out below procedure, check all the related connectors are properly inserted.

### 1) INSPECTION PROCEDURE

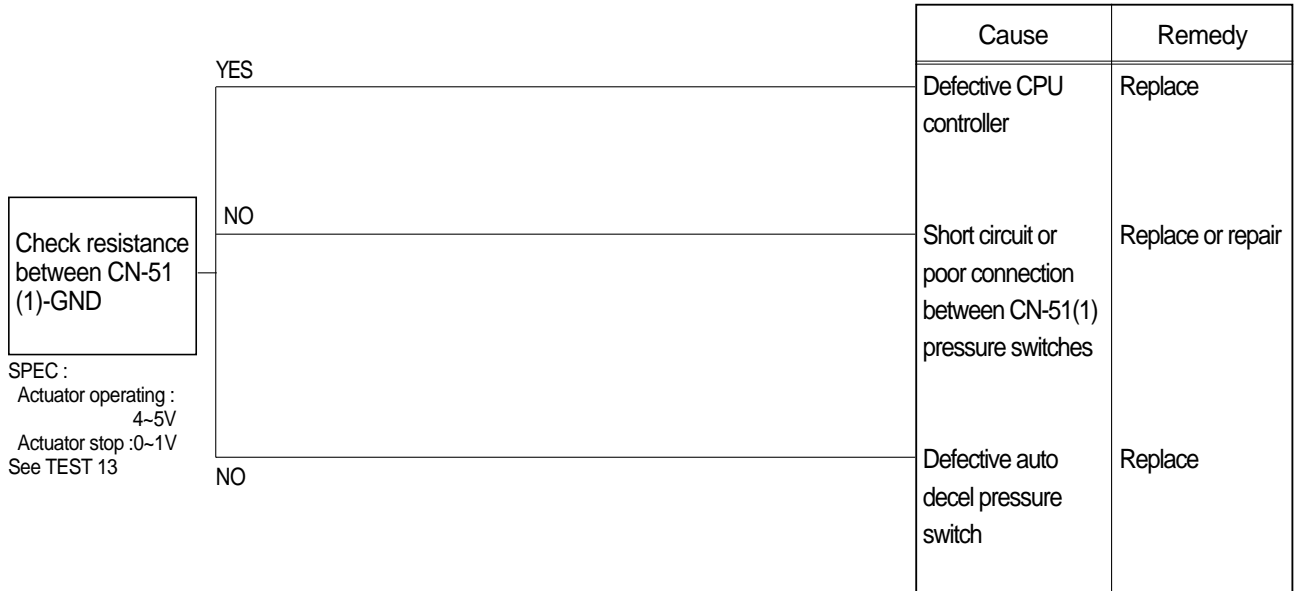

### Wiring diagram



14076TS31

## 2) TEST PROCEDURE

(1) **Test 13** : Check voltage at CN-51(1) and ground.

Prepare 1 piece of thin sharp pin, steel or copper.

Starting key ON.

Insert prepared pin to rear side of connectors : One pin to (1) of CN-51.

Check voltage as figure.

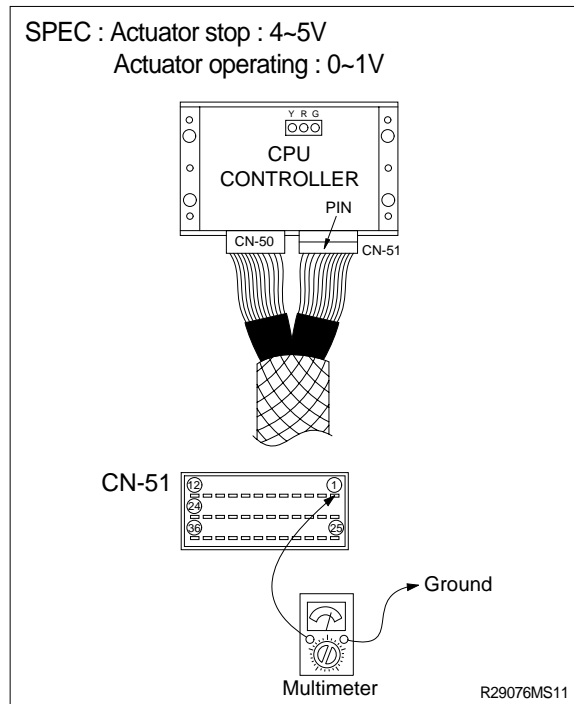

## 7. MALFUNCTION OF WARMING UP

Before carrying out below procedure, check all the related connectors are properly inserted.

### 1) INSPECTION PROCEDURE

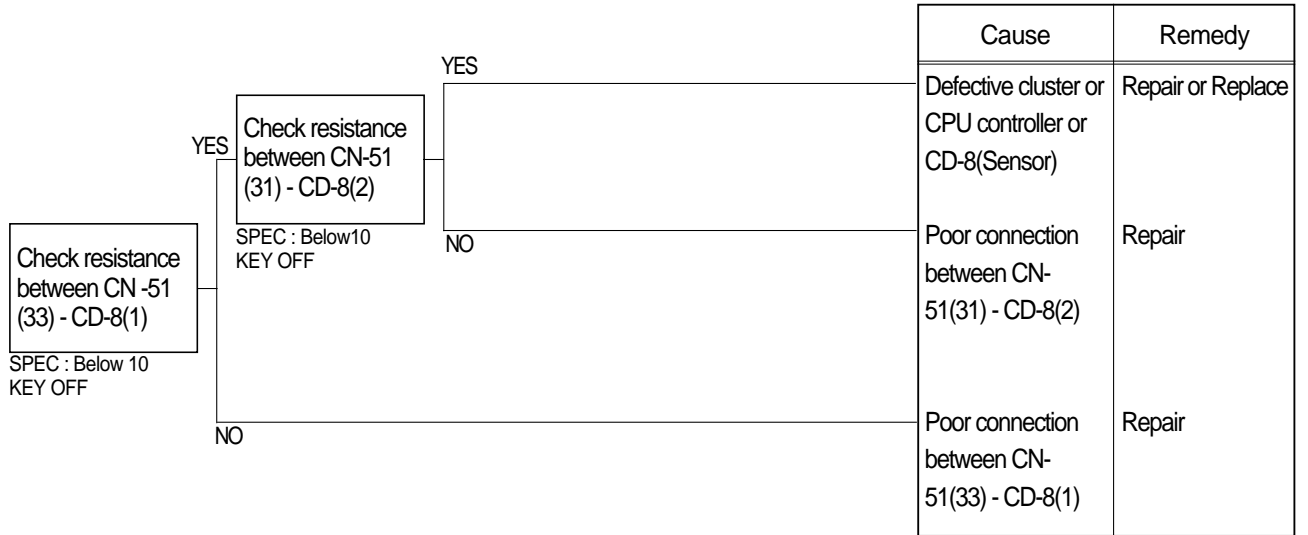

### Wiring diagram

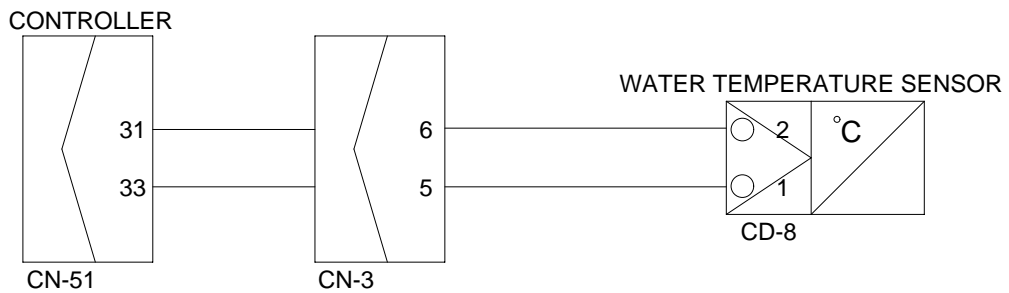

14076TS29

## 8. MALFUNCTION OF POWER MAX

Before carrying out below procedure, check all the related connectors are properly inserted.

### 1) INSPECTION PROCEDURE

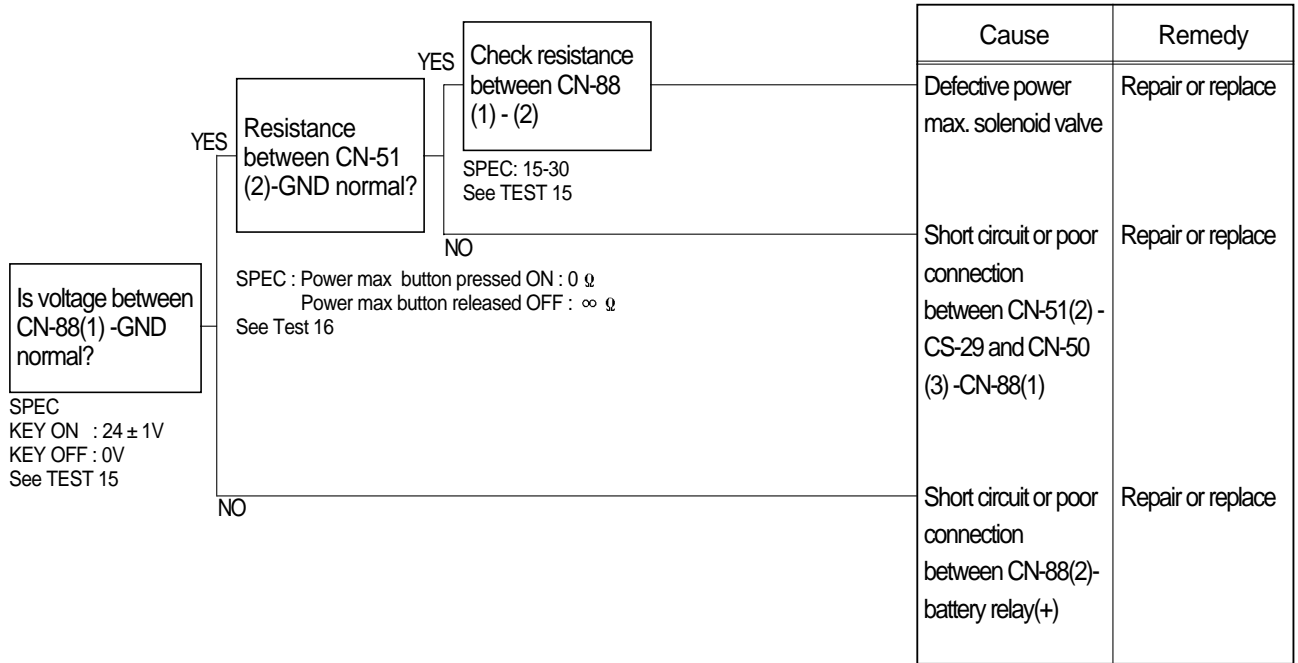

### Wiring diagram

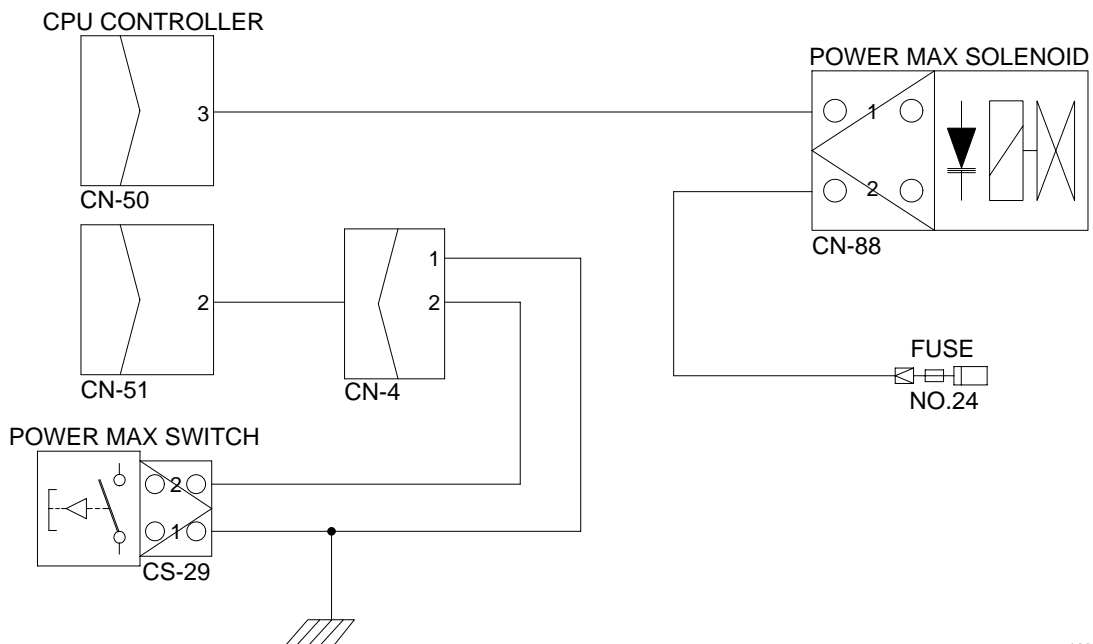

16076MS06



## 2) TEST PROCEDURE

- (1) **Test 15:** Check voltage between connector CN-88 - GND.

Start key ON.

Disconnect connector CN-88 from power max solenoid valve.

Check voltage as figure.

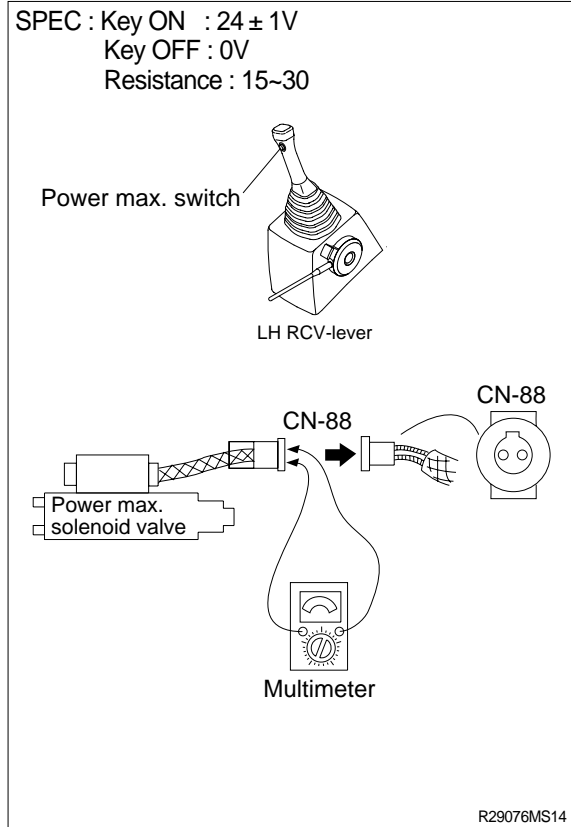

- (2) **Test 16:** Check resistance between connector CN-51(2)-GND.

Starting key OFF.

Remove CPU controller and disconnect connector CN-51 from CPU controller.

Check resistance as figure.

