

GROUP 4 HYDRAULIC SYSTEM

1. HYDRAULIC COMPONENTS MOUNTING 1

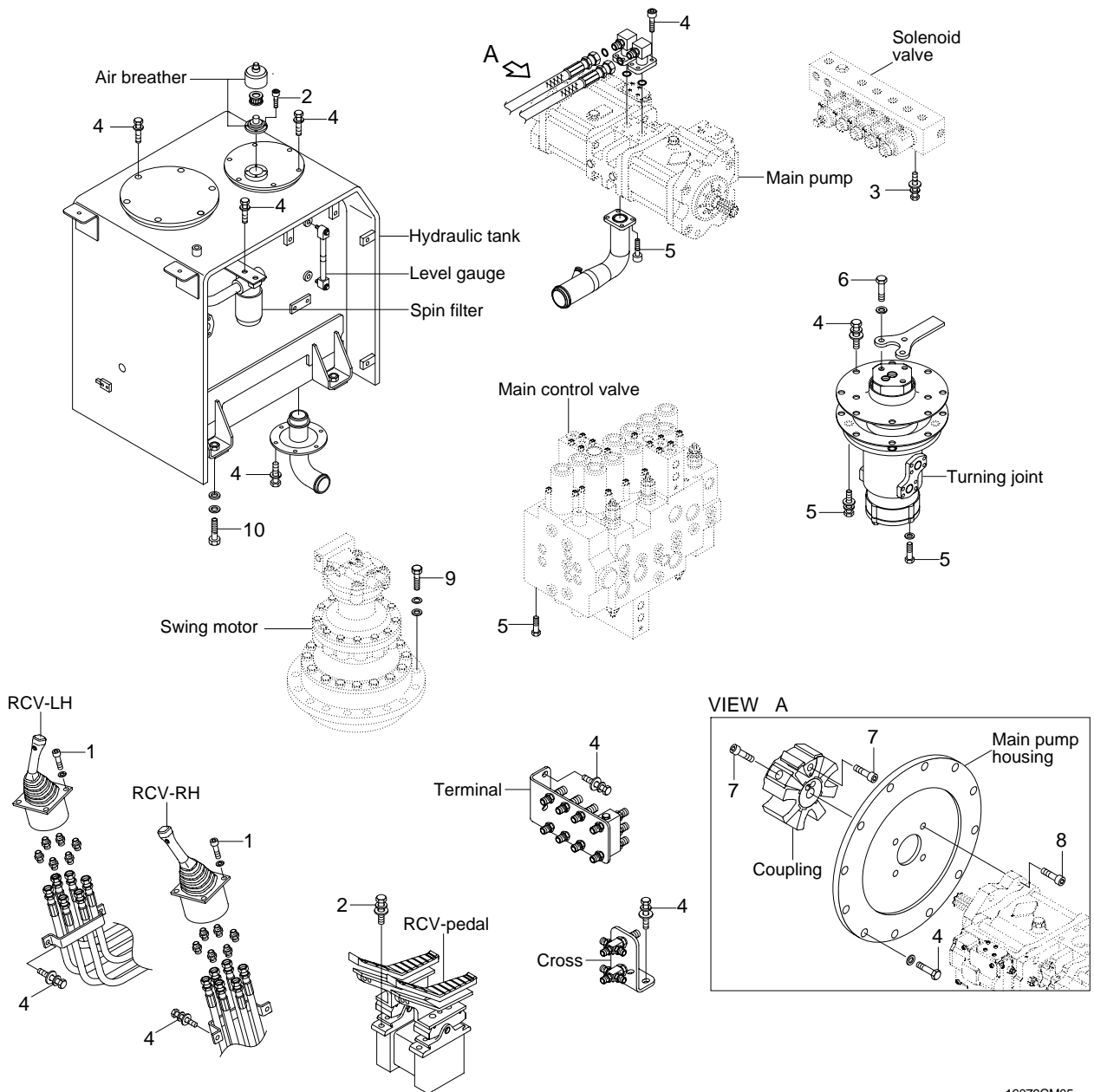

16079CM05

· Tightening torque

Item	Size	kgf · m	lbf · ft
1	M 6 × 1.0	1.05 ± 0.2	7.6 ± 1.45
2	M 6 × 1.0	1.44 ± 0.3	10.4 ± 2.2
3	M 8 × 1.25	2.5 ± 0.5	18.1 ± 3.6
4	M10 × 1.5	6.9 ± 1.4	49.9 ± 10.1
5	M12 × 1.75	12.2 ± 1.3	88.2 ± 9.4

Item	Size	kgf · m	lbf · ft
6	M14 × 2.0	19.6 ± 2.9	142 ± 21
7	M16 × 2.0	22.0 ± 1.0	159 ± 7.2
8	M16 × 2.0	22.1 ± 2.4	160 ± 17.4
9	M20 × 2.5	57.9 ± 8.7	419 ± 62.9
10	M20 × 2.5	45 ± 5.1	325 ± 36.9

2. HYDRAULIC COMPONENTS MOUNTING 2

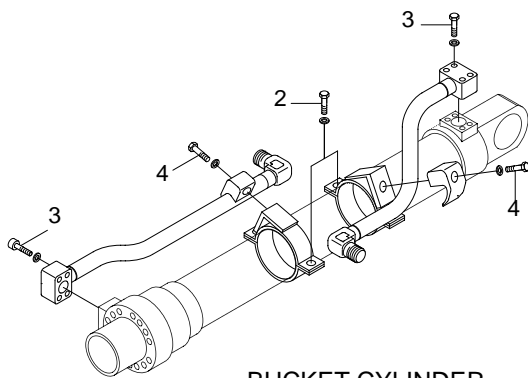
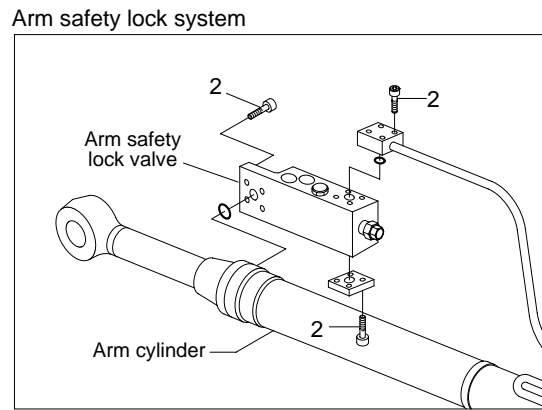
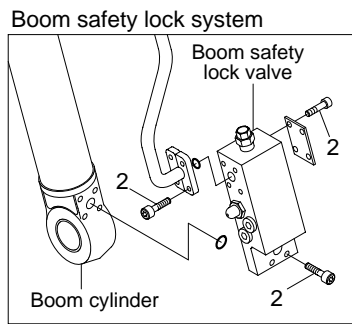
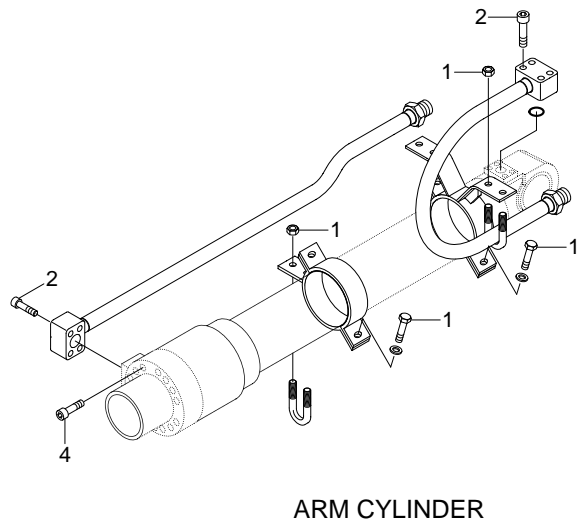
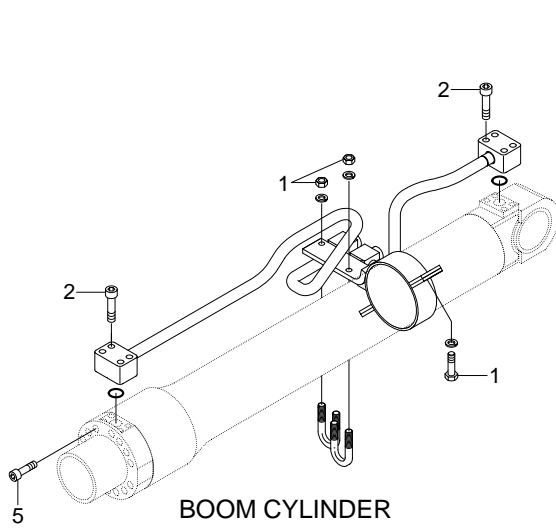

16079CM07

· Tightening torque

Item	Size	kgf · m	lbf · ft
1	M10 × 1.5	3.2 ± 0.3	23.1 ± 2.2
2	M10 × 1.5	5.4 ± 0.5	39.1 ± 3.6
3	M12 × 1.75	5.5 ± 0.6	39.8 ± 4.3

Item	Size	kgf · m	lbf · ft
4	M16 × 2.0	23 ± 2.0	166 ± 14.5
5	M18 × 2.5	32 ± 3.0	232 ± 21.7
-	-	-	-