

GROUP 09 BOOM, ARM AND BUCKET CYLINDERS

1. REMOVAL AND INSTALL

1) BUCKET CYLINDER

(1) Removal

Expand the arm and bucket fully, lower the work equipment to the ground and stop the engine.

Operate the control levers and pedals several times to release the remaining pressure in the hydraulic piping.

⚠ Loosen the breather slowly to release the pressure inside the hydraulic tank.

Escaping fluid under pressure can penetrate the skin causing serious injury.

Fit blind plugs in the hoses after disconnecting them, to prevent dirt or dust from entering.

Set block between bucket cylinder and arm.

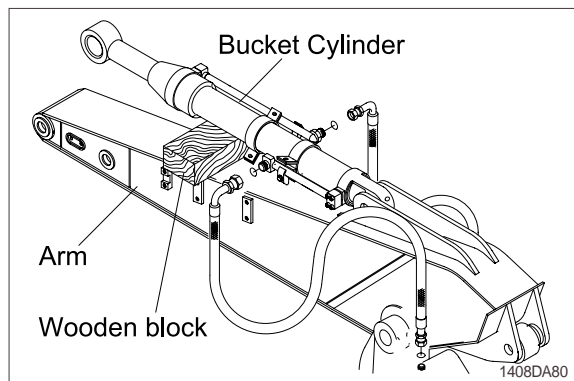

Remove bolt(2), nut(3) and pull out pin (1).

Tie the rod with wire to prevent it from coming out.

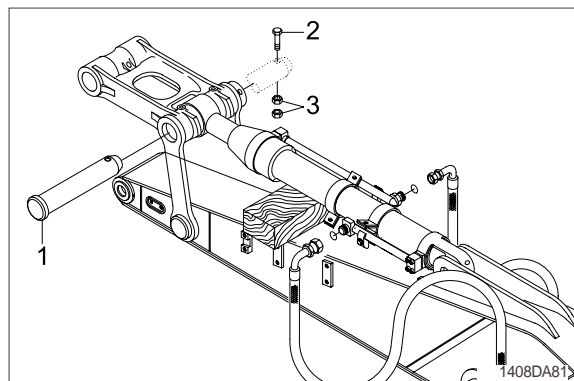

Disconnect bucket cylinder hoses(4) and put plugs(5) on cylinder pipe.

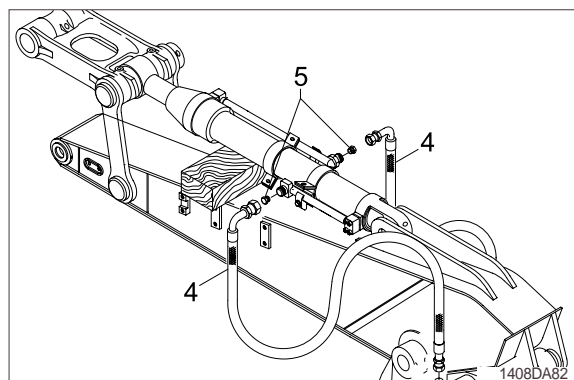

Sling bucket cylinder assembly(8) and remove bolt(6) then pull out pin (5).
Remove bucket cylinder assembly(8).
· Weight : 140kg(310lb)

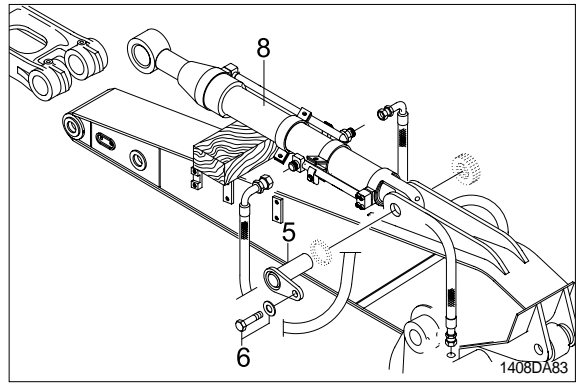

(2) Install

Carry out installation in the reverse order to removal.

- ⚠ When aligning the mounting position of the pin, do not insert your fingers in the pin hole.

Bleed the air from the bucket cylinder.

Confirm the hydraulic oil level and check the hydraulic oil leak or not.

2) ARM CYLINDER

(1) Removal

Expand the arm and bucket fully, lower the work equipment to the ground and stop the engine.

Operate the control levers and pedals several times to release the remaining pressure in the hydraulic piping.

⚠ Loosen the breather slowly to release the pressure inside the hydraulic tank.

Escaping fluid under pressure can penetrate the skin causing serious injury.

Fit blind plugs in the hoses after disconnecting them, to prevent dirt or dust from entering.

Set block between arm cylinder and boom.

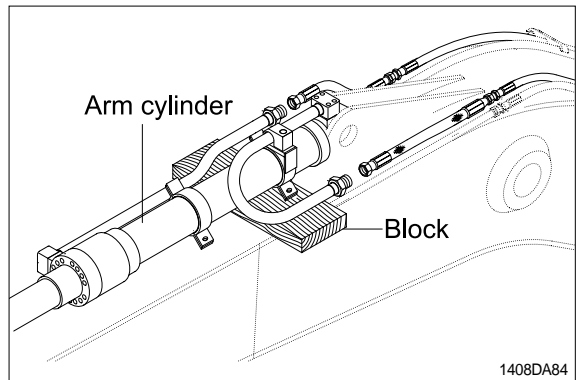

Remove bolt(2) and pull out pin(1).

Tie the rod with wire to prevent it from coming out.

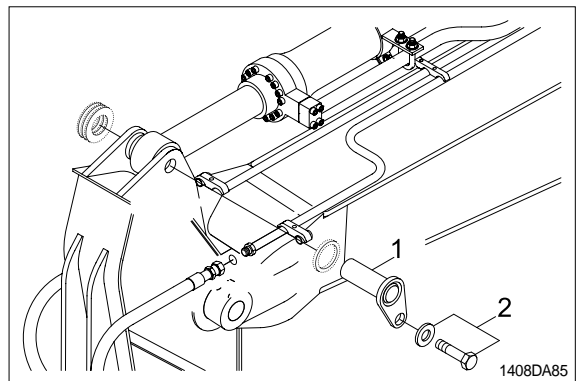

Disconnect arm cylinder hoses(4) and put plugs on cylinder pipe.

Disconnect greasing pipings(5).

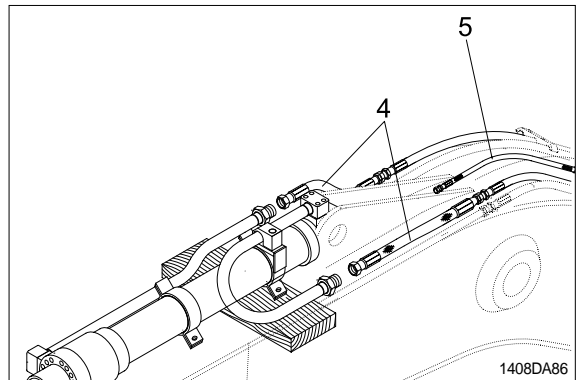

Sling arm assembly(8) and remove bolt (7) then pull out pin(6).
Remove arm cylinder assembly(8).
· Weight : 180kg(400lb)

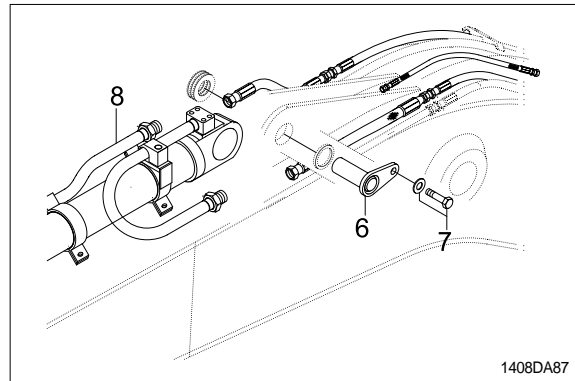

(2) Install

Carry out installation in the reverse order to removal.

- ⚠ When aligning the mounting position of the pin, do not insert your fingers in the pin hole.

Bleed the air from the arm cylinder.

Confirm the hydraulic oil level and check the hydraulic oil leak or not.

3) BOOM CYLINDER

(1) Removal

Expand the arm and bucket fully, lower the work equipment to the ground and stop the engine.

Operate the control levers and pedals several times to release the remaining pressure in the hydraulic piping.

⚠ Loosen the breather slowly to release the pressure inside the hydraulic tank.

Escaping fluid under pressure can penetrate the skin causing serious injury.

Fit blind plugs in the hoses after disconnecting them, to prevent dirt or dust from entering.

Disconnect greasing hoses(1).

Sling boom cylinder assembly.

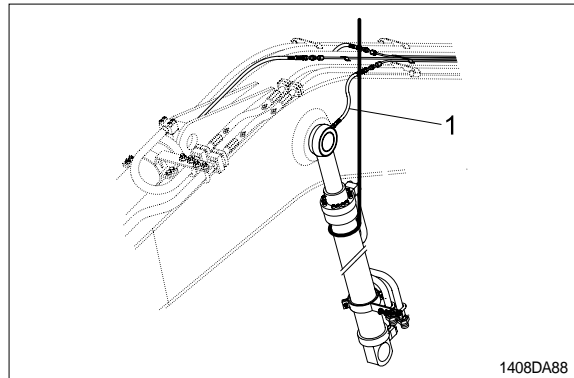

Remove bolt(4), stop plate(5) and pull out pin(2).

Tie the rod with wire to prevent it from coming out.

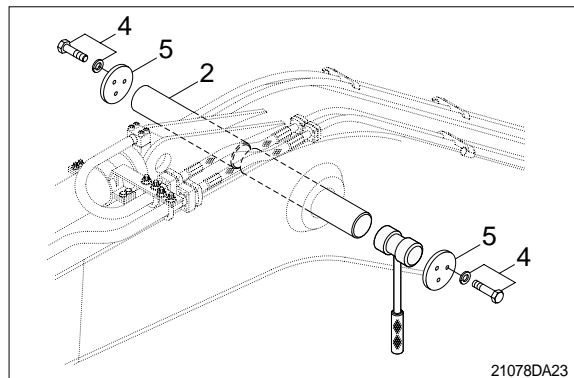

Lower the boom cylinder assembly(6) on a stand.

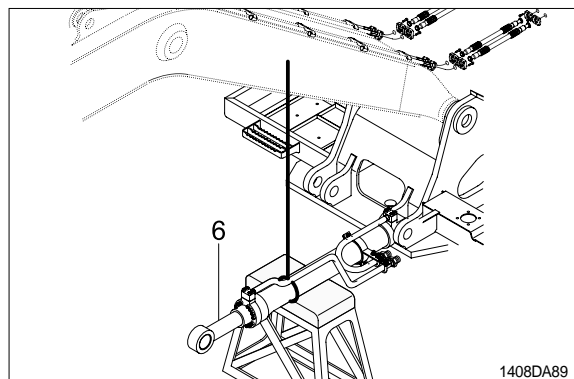

Disconnect boom cylinder hoses(7) and put plugs on cylinder pipe.

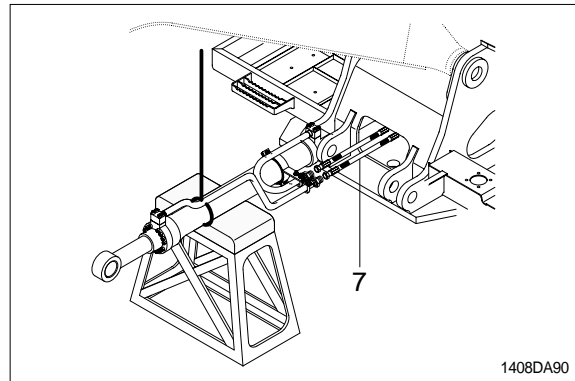

Remove bolt(9) and pull out pin(8).
Remove boom cylinder assembly(6).
· Weight : 160kg(350lb)

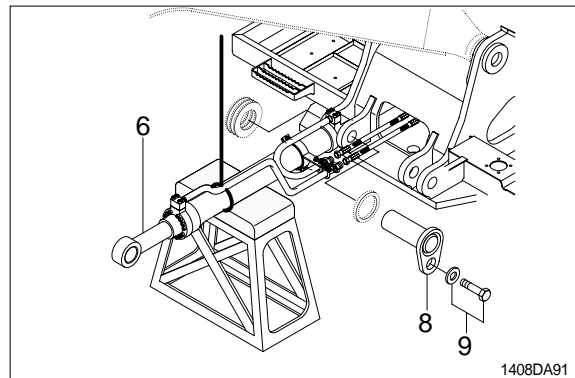

(2) Install

Carry out installation in the reverse order to removal.

▲ When aligning the mounting position of the pin, do not insert your fingers in the pin hole.

Bleed the air from the boom cylinder.

Confirmed the hydraulic oil level and check the hydraulic oil leak or not.

2. DISASSEMBLY AND ASSEMBLY

1) STRUCTURE

(1) Bucket cylinder

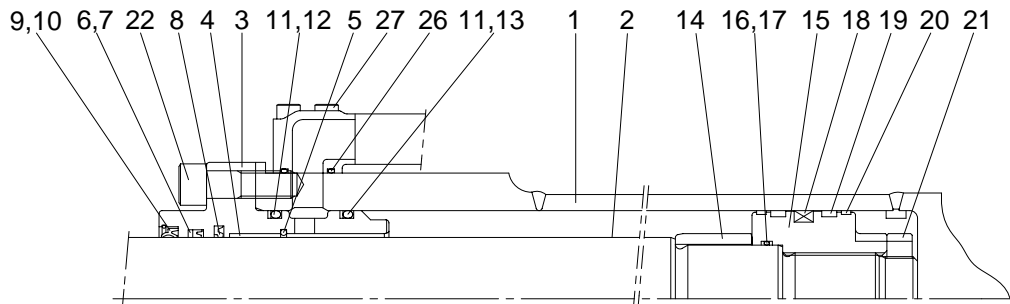

Internal detail

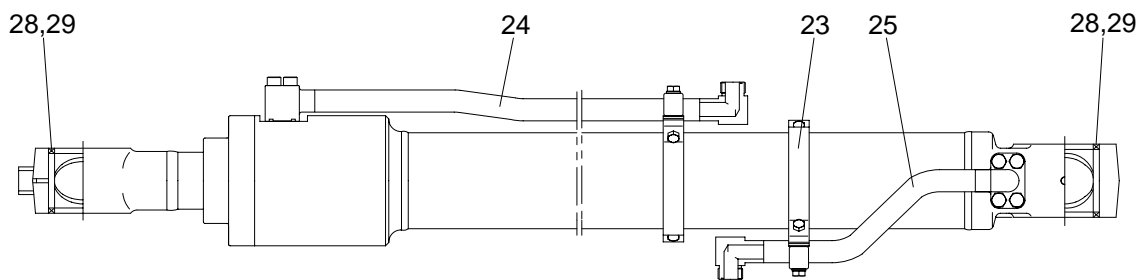

17W78CY01

1	Tube assembly	11	O-ring	21	Lock nut
2	Rod assembly	12	Back-up ring	22	Socket head bolt
3	Gland	13	Back-up ring	23	Band assembly
4	DD2 bushing	14	Cushion ring	24	Pipe assembly(R)
5	Snap ring	15	Piston	25	Pipe assembly(B)
6	Rod seal	16	O-ring	26	O-ring
7	Back-up ring	17	Back-up ring	27	Socket head bolt
8	Buffer ring	18	Piston seal	28	Pin bush
9	Dust wiper	19	Wear ring	29	Dust seal
10	Snap ring	20	Dust ring		

(2) Arm cylinder

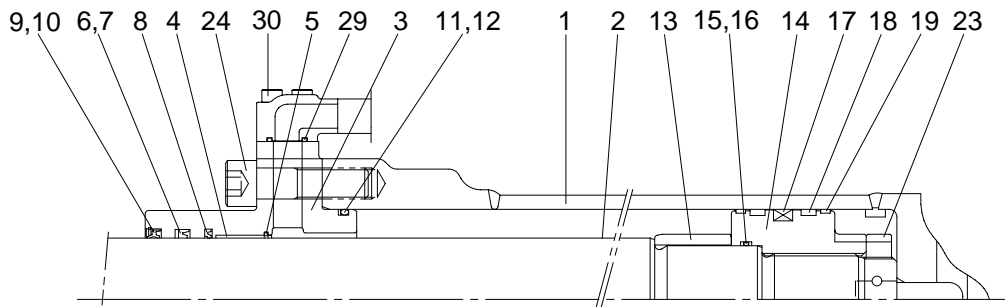

Internal detail

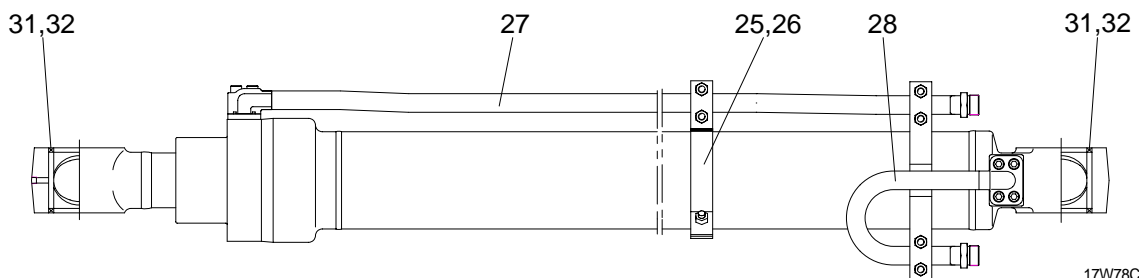

17W78CY02

1	Tube assembly	11	O-ring	24	Socket head bolt
2	Rod assembly	12	Back-up ring	25	Band assembly(R)
3	Gland	13	Cushion ring	26	Band assembly(B)
4	DD2 bushing	14	Piston	27	Pipe assembly(R)
5	Snap ring	15	O-ring	28	Pipe assembly(B)
6	Rod seal	16	Back-up ring	29	O-ring
7	Back-up ring	17	Piston seal	30	Socket head bolt
8	Buffer ring	18	Wear ring	31	Pin bush
9	Dust wiper	19	Dust ring	32	Dust seal
10	Snap ring	20	Lock nut		

(3) Boom cylinder

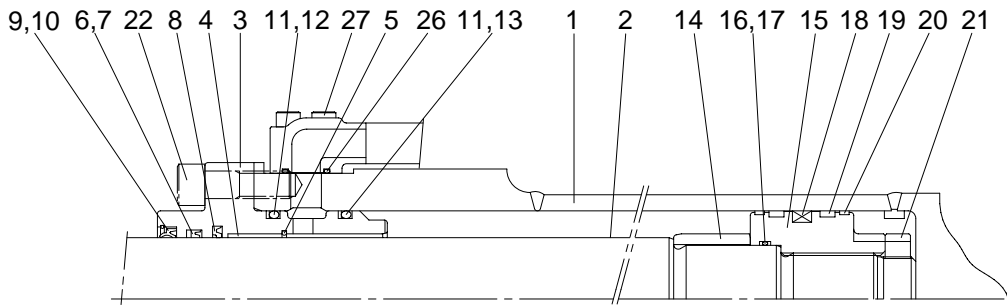

Internal detail

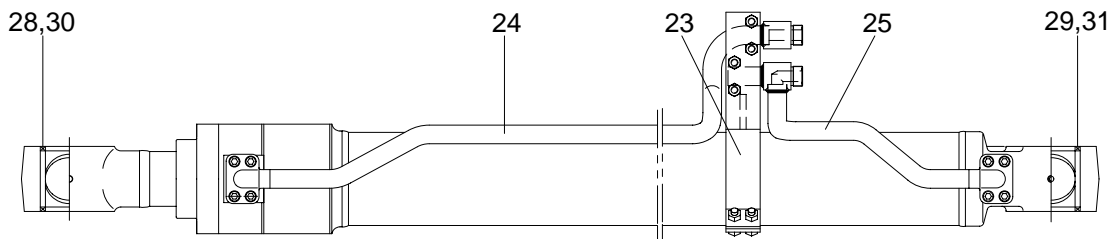

17W78CY03

- | | | | | | |
|----|---------------|----|--------------|----|-------------------------|
| 1 | Tube assembly | 12 | Buck-up ring | 22 | Socket head bolt |
| 2 | Rod assembly | 13 | Buck-up ring | 23 | Band assembly |
| 3 | Gland | 14 | Cushion ring | 24 | Pipe assembly(R, LH/RH) |
| 4 | DD2 bush | 15 | Piston | 25 | Pipe assembly(B, LH/RH) |
| 5 | Snap ring | 16 | O-ring | 26 | O-ring |
| 6 | Rod seal | 17 | Buck-up ring | 27 | Socket head bolt |
| 7 | Buck-up ring | 18 | Piston seal | 28 | Pin bush |
| 8 | Buffer ring | 19 | Wear ring | 29 | Pin bush |
| 9 | Dust wiper | 20 | Dust ring | 30 | Dust seal |
| 10 | Snap ring | 21 | Lock nut | 31 | Dust seal |
| 11 | O-ring | | | | |

2) TOOLS AND TIGHTENING TORQUE

(1) Tools

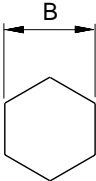
Allen wrench	6		
	8		
	14		
	17		
Spanner	7		
	8		
(-) Driver	Small and large sizes		
Torque wrench	Capable of tightening with the specified torques		

(2) Tightening torque

Part name		Item	Size	Torque	
				kgf · m	lbf · ft
Socket head bolt	Bucket cylinder	22	M18	23 ± 3.0	232 ± 21.7
	Boom cylinder				
	Arm cylinder	24	M16	23 ± 3.0	166 ± 14.5
	Bucket cylinder	27	M10	5.4 ± 0.5	39.1 ± 3.6
	Boom cylinder				
	Arm cylinder				
Lock nut	Bucket cylinder	21	M55	100 ± 10.0	723 ± 72.3
	Boom cylinder	21	M55		
	Arm cylinder	23	M60		
Piston	Bucket cylinder	15	-	150 ± 15.0	1085 ± 109
	Boom cylinder				
	Arm cylinder	14			

3) DISASSEMBLY

(1) Remove cylinder head and piston rod

Hold the clevis section of the tube in a vise.

Use mouth pieces so as not to damage the machined surface of the cylinder tube. Do not make use of the outside piping as a locking means.

Pull out rod assembly(2) about 200mm (7.1in). Because the rod assembly is rather heavy, finish extending it with air pressure after the oil draining operation.

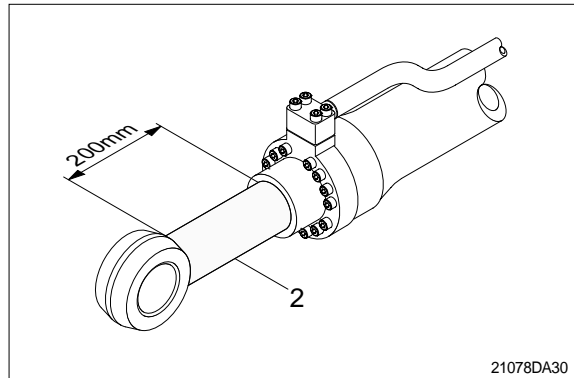

Loosen and remove socket bolts(22) of the gland in sequence.

Cover the extracted rod assembly(2) with rag to prevent it from being accidentally damaged during operation.

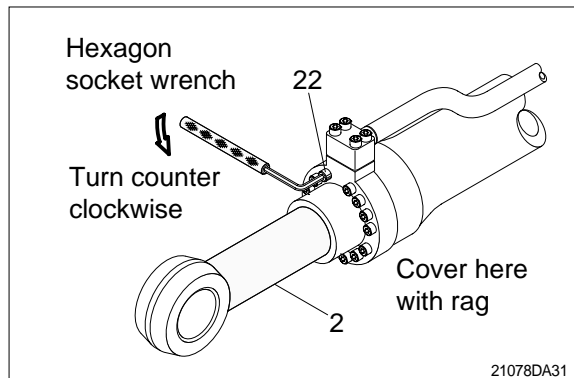

Draw out cylinder head and rod assembly together from tube assembly(1).

Since the rod assembly is heavy in this case, lift the tip of the rod assembly(2) with a crane or some means and draw it out. However, when rod assembly(2) has been drawn out to approximately two thirds of its length, lift it in its center to draw it completely.

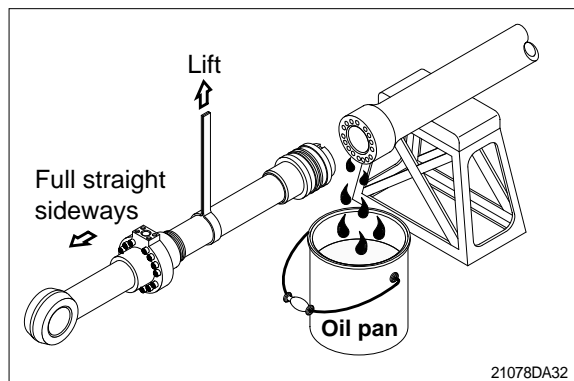

Note that the plated surface of rod assembly(2) is to be lifted. For this reason, do not use a wire sling and others that may damage it, but use a strong cloth belt or a rope.

Place the removed rod assembly on a wooden V-block that is set level. Cover a V-block with soft rag.

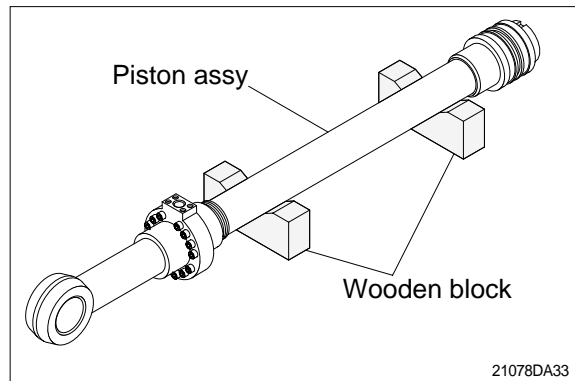

(2) Remove piston and cylinder head

Remove lock nut(21).
 Since lock nut(21) and lock washer(22) is tightened to a high torque, use a hydraulic and power wrench that utilizes a hydraulic cylinder, to remove the lock nut(21) and lock washer (22).
 Remove piston assembly(14), back up ring(16), and O-ring(15).

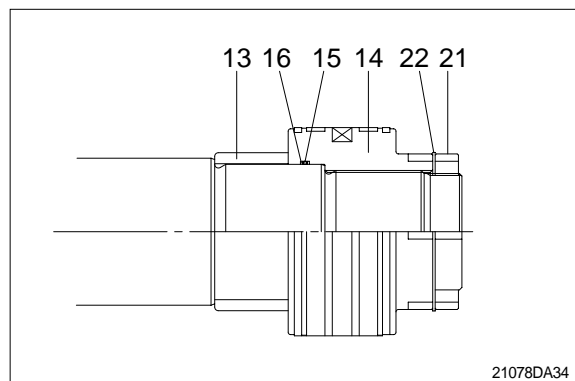

Remove the cylinder head assembly from rod assembly(2).
 If it is too heavy to move, move it by striking the flanged part of cylinder head with a plastic hammer.
 Pull it straight with cylinder head assembly lifted with a crane.
 Exercise care so as not to damage the lip of rod bushing(4) and packing (5,6,7,8,9,10) by the threads of rod assembly(2).

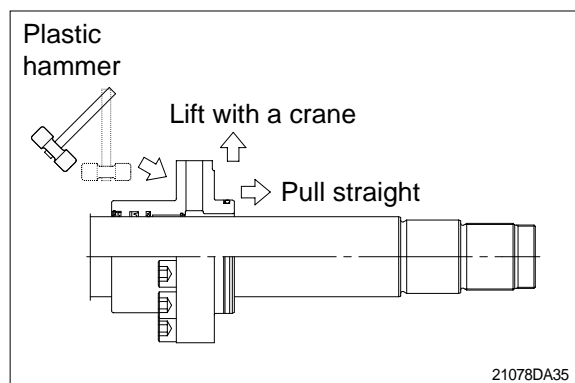

(3) Disassemble the piston assembly

Remove wear ring(18).

Remove dust ring(19) and piston seal (17).

Exercise care in this operation not to damage the grooves.

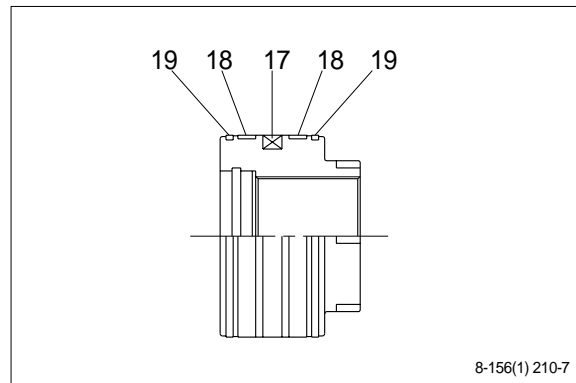

(4) Disassemble cylinder head assembly

Remove back up ring(12) and O-ring (11).

Remove snap ring(10), dust wiper(9).

Remove back up ring(7), rod seal(6) and buffer ring(8).

Exercise care in this operation not to damage the grooves.

Do not remove seal and ring, if does not damaged.

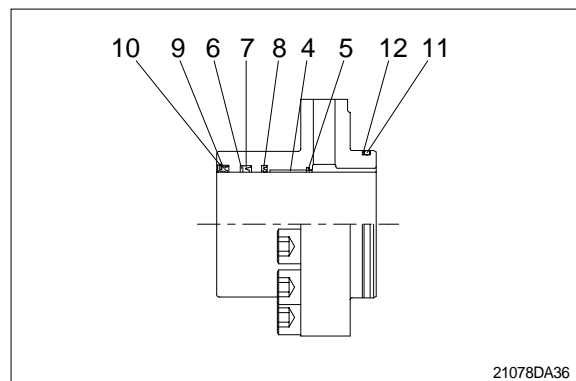

4) ASSEMBLY

(1) Assemble cylinder head assembly

Check for scratches or rough surfaces if found smooth with an oil stone.

Coat the inner face of gland(3) with hydraulic oil.

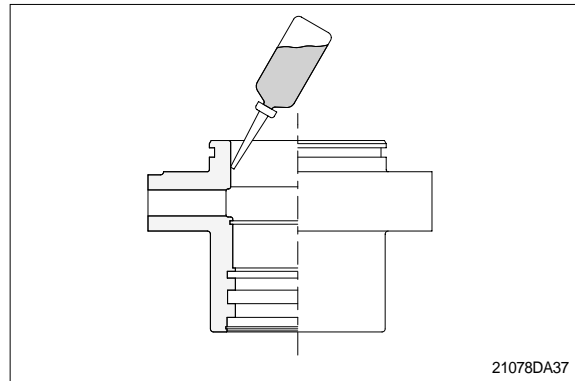

Coat dust wiper(9) with grease and fit dust wiper(9) to the bottom of the hole of dust seal.

At this time, press a pad metal to the metal ring of dust seal.

Fit snap ring(10) to the stop face.

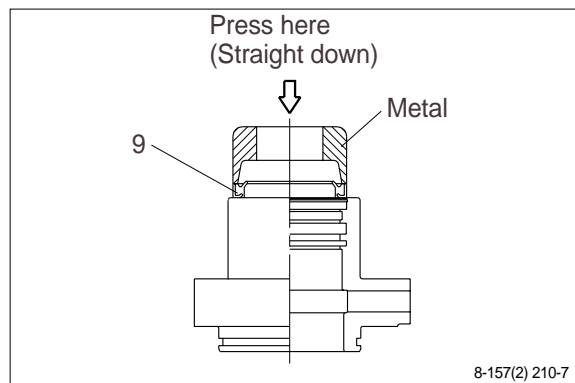

Fit back up ring(7), rod seal(6) and buffer ring(8) to corresponding grooves, in that order.

Coat each packing with hydraulic oil before fitting it.

Insert the backup ring until one side of it is inserted into groove.

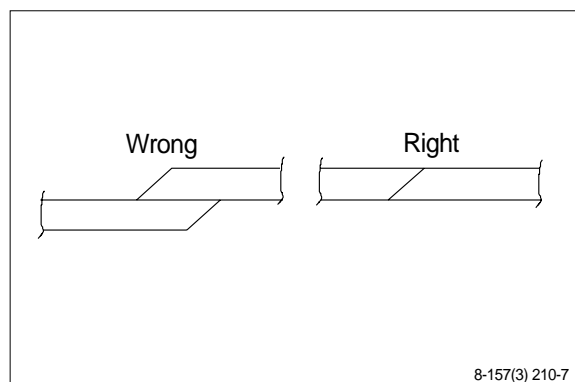

Rod seal(6) has its own fitting direction. Therefore, confirm it before fitting them. Fitting rod seal(6) upside down may damage its lip. Therefore check the correct direction that is shown in fig.

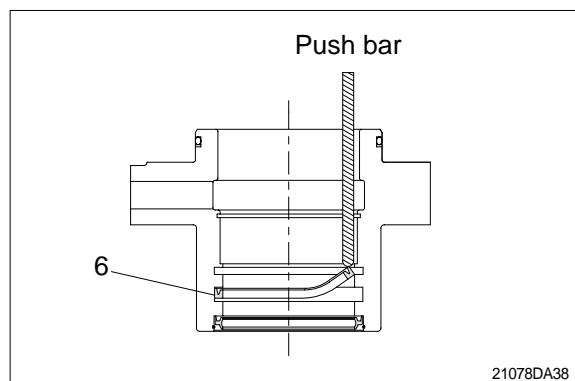

Fit back up ring(12) to gland(3).
 Put the backup ring in the warm water of 30~50,C.
 Fit O-ring(11) to gland(3).

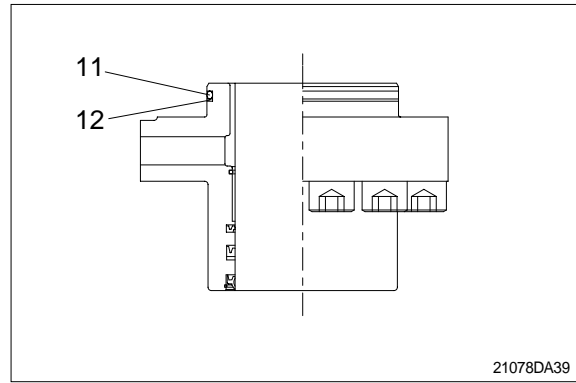

(2) Assemble piston assembly

Check for scratches or rough surfaces.
 If found smooth with an oil stone.
 Coat the outer face of piston(14) with hydraulic oil.

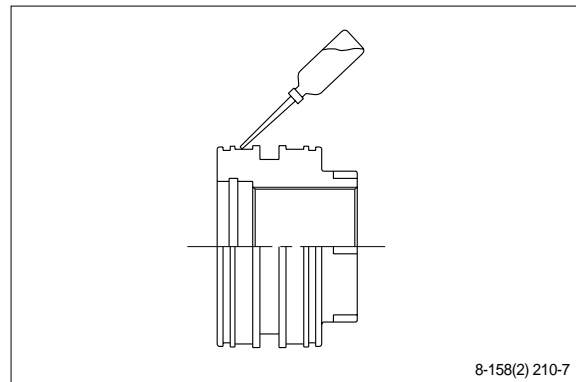

Fit piston seal(17) to piston.
 Put the piston seal in the warm water of 60~100,C for more than 5 minutes.
 After assembling the piston seal, press its outer diameter to fit in.

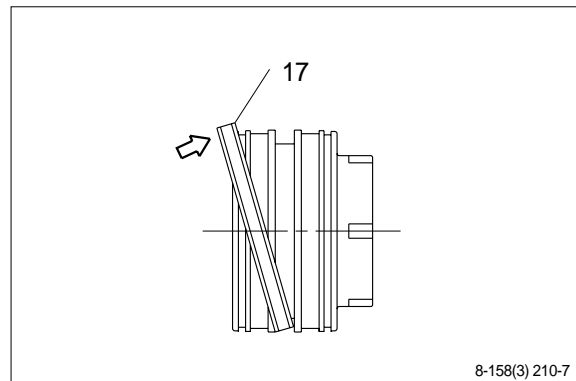

Fit wear ring(18) and dust ring(19) to piston(14).

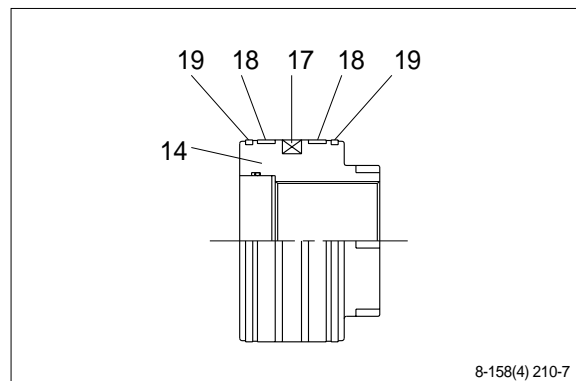

(3) Install piston and cylinder head

Fix the rod assembly to the work bench.
 Apply hydraulic oil to the outer surface of rod assembly(2), the inner surface of piston and cylinder head.
 Insert cylinder head assembly to rod assembly.

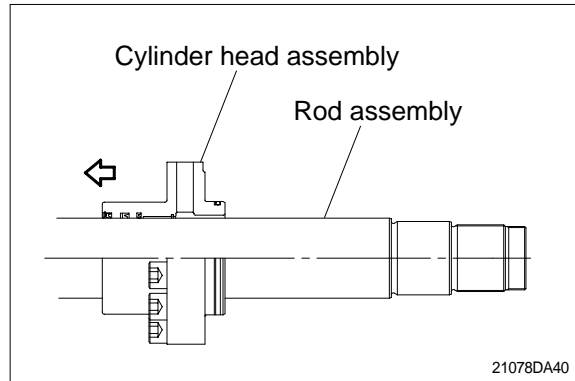

Insert cushion ring(13) to rod assembly.
 Note that cushion ring(13) has a direction in which it should be fitted.

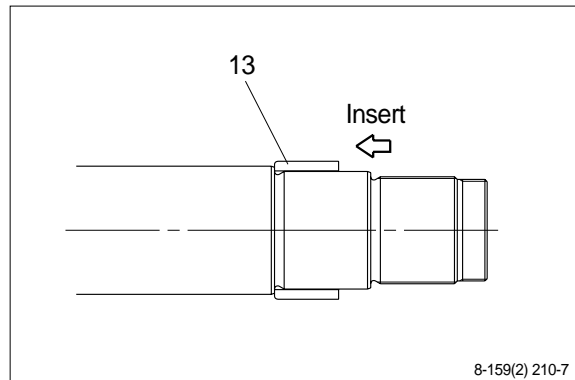

Fit piston assembly to rod assembly.
 · Tightening torque : $150 \pm 15.0 \text{ kgf} \cdot \text{m}$
 ($1085 \pm 109 \text{ lbf} \cdot \text{ft}$)

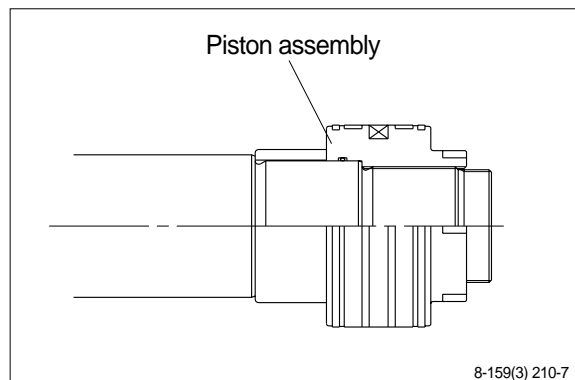

Fit lock nut to piston.
 · Tightening torque :

Item		kgf · m	lbf · ft
Bucket	21	100 ± 10	723 ± 72.3
Boom	21	100 ± 10	723 ± 72.3
Arm	23	100 ± 10	723 ± 72.3

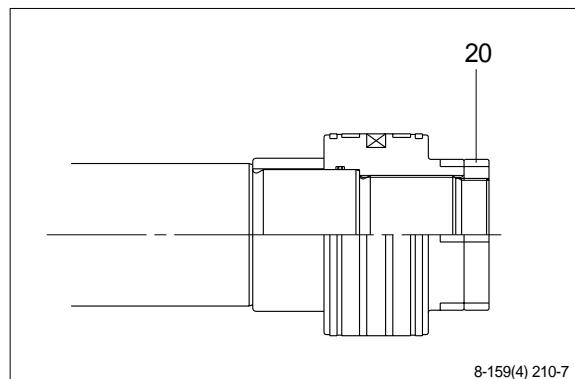

(3) Overall assemble

Place a V-block on a rigid work bench.
Mount the tube assembly(1) on it and fix the assembly by passing a bar through the clevis pin hole to lock the assembly.
Insert the rod assembly in to the tube assembly, while lifting and moving the rod assembly with a crane.
Be careful not to damage piston seal by thread of tube assembly.
Match the bolt holes in the cylinder head flange to the tapped holes in the tube assembly and tighten socket bolts to a specified torque.
Refer to the table of tightening torque.

