

GROUP 10 UNDERCARRIAGE

1. TRACK LINK

1) REMOVAL

- (1) Move track link until master pin is over front idler in the position put wooden block as shown.
- (2) Loosen tension of the track link.
 - ※ If track tension is not relieved when the grease valve is loosened, move the machine backwards and forwards.
- (3) Push out master pin by using a suitable tool.

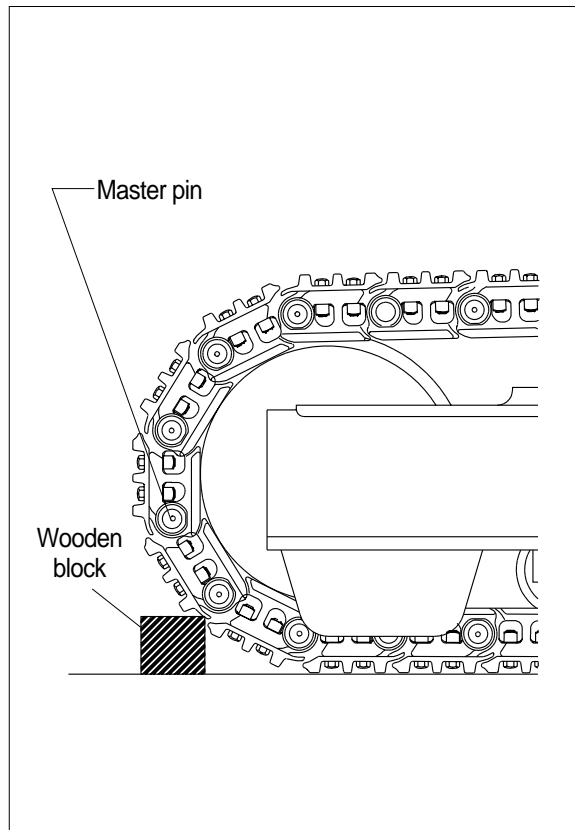

- (4) Move the machine slowly in reverse, and lay out track link assembly (1).
 - ※ Jack up the machine and put wooden block under the machine.
 - ※ Don't get close to the sprocket side as the track shoe plate may fall down on your feet.

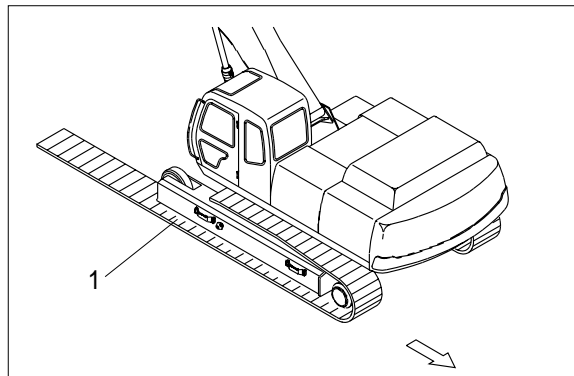

2) INSTALL

- (1) Carry out installation in the reverse order to removal.
 - ※ Adjust the tension of the track link.

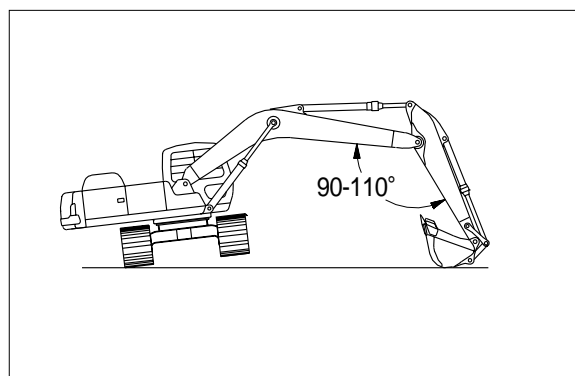

2. CARRIER ROLLER

1) REMOVAL

(1) Loosen tension of the track link.

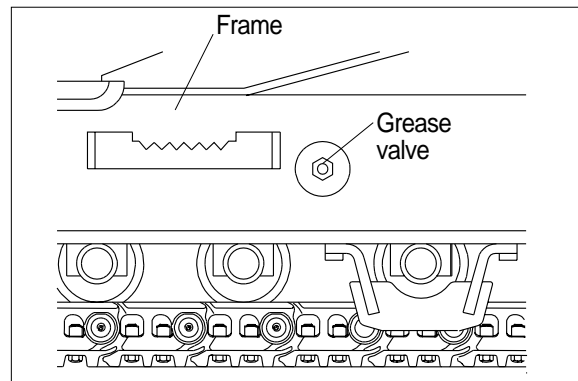

(2) Jack up the track link height enough to permit carrier roller removal.

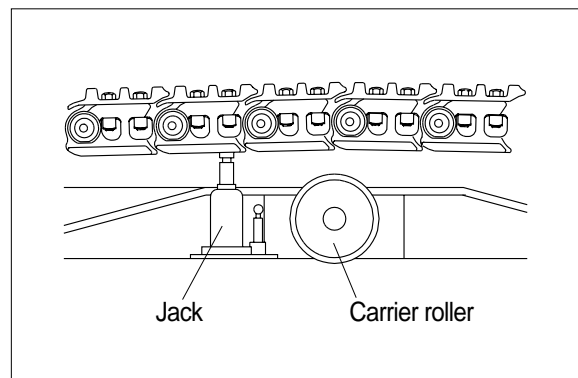

(3) Loosen the lock nut (1).

(4) Open bracket(2) with a screwdriver, push out from inside, and remove carrier roller assembly.

• Weight : 20.6kg(45.4lb)

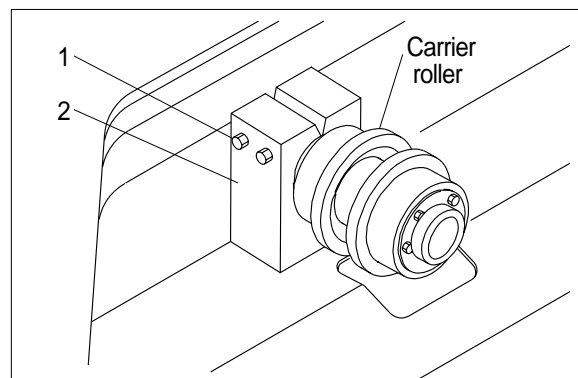

2) INSTALL

(1) Carry out installation in the reverse order to removal.

3. TRACK ROLLER

1) REMOVAL

- (1) Loosen tension of the track link.

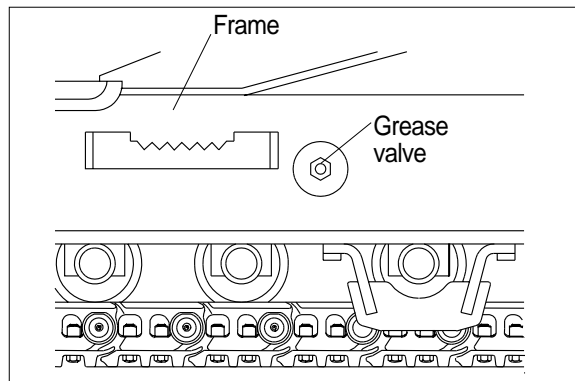

- (2) Using the work equipment, push up track frame on side which is to be removed.
※ After jack up the machine, set a block under the unit.

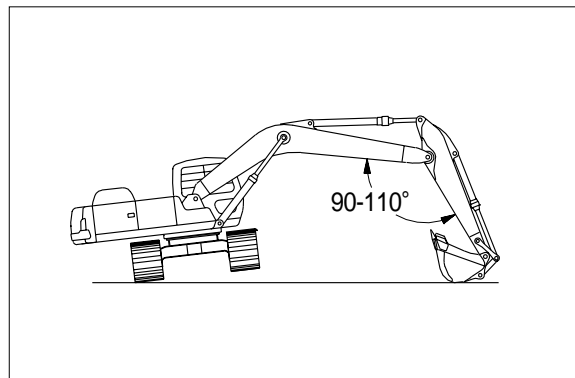

- (3) Remove the mounting bolt(1) and draw out the track roller(2).
· Weight : 38.3kg(84.4lb)

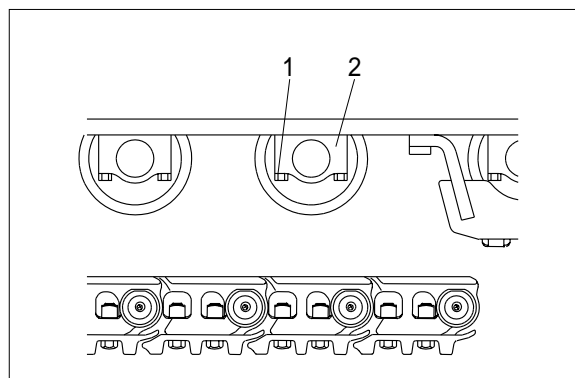

2) INSTALL

- (1) Carry out installation in the reverse order to removal.

4. IDLER AND RECOIL SPRING

1) REMOVAL

- (1) Remove the track link.
For detail, see **removal of track link**

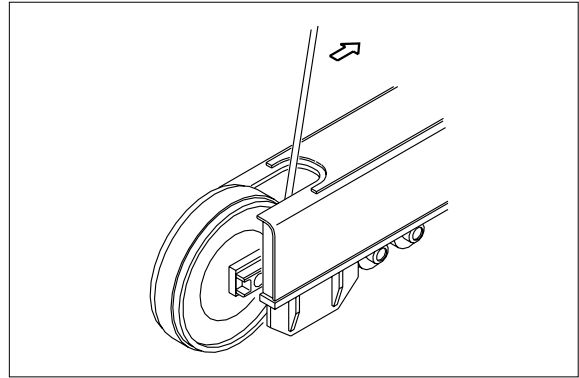

- (2) Sling the adjust component(1) and pull out idler and recoil spring assembly from track frame, using a pry.
· Weight : 270kg (595lb)

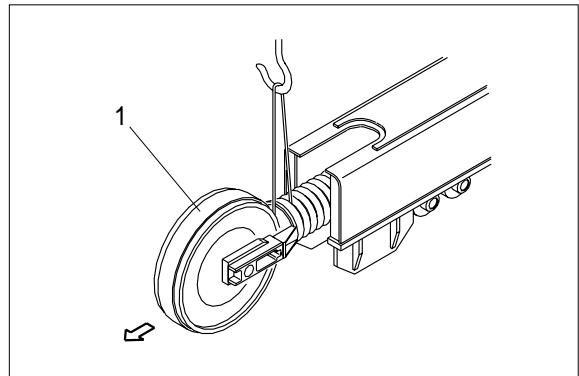

- (3) Remove the bolts(2), washers(3) and separate idler from recoil spring.

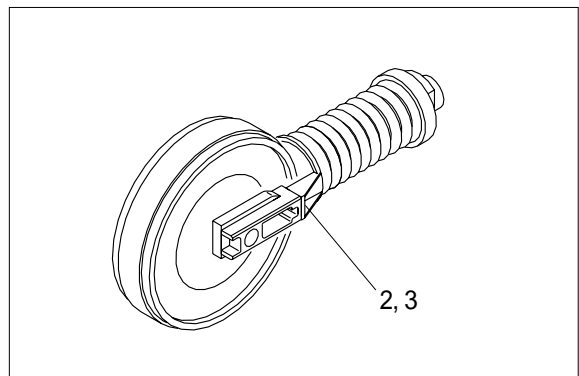

2) INSTALL

- (1) Carry out installation in the reverse order to removal.
* **Make sure that the boss on the end face of the recoil cylinder rod is in the hole of the track frame.**

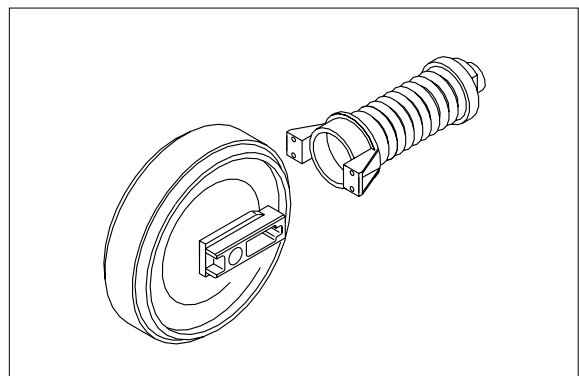

3) DISASSEMBLY AND ASSEMBLY OF IDLER

(1) Structure

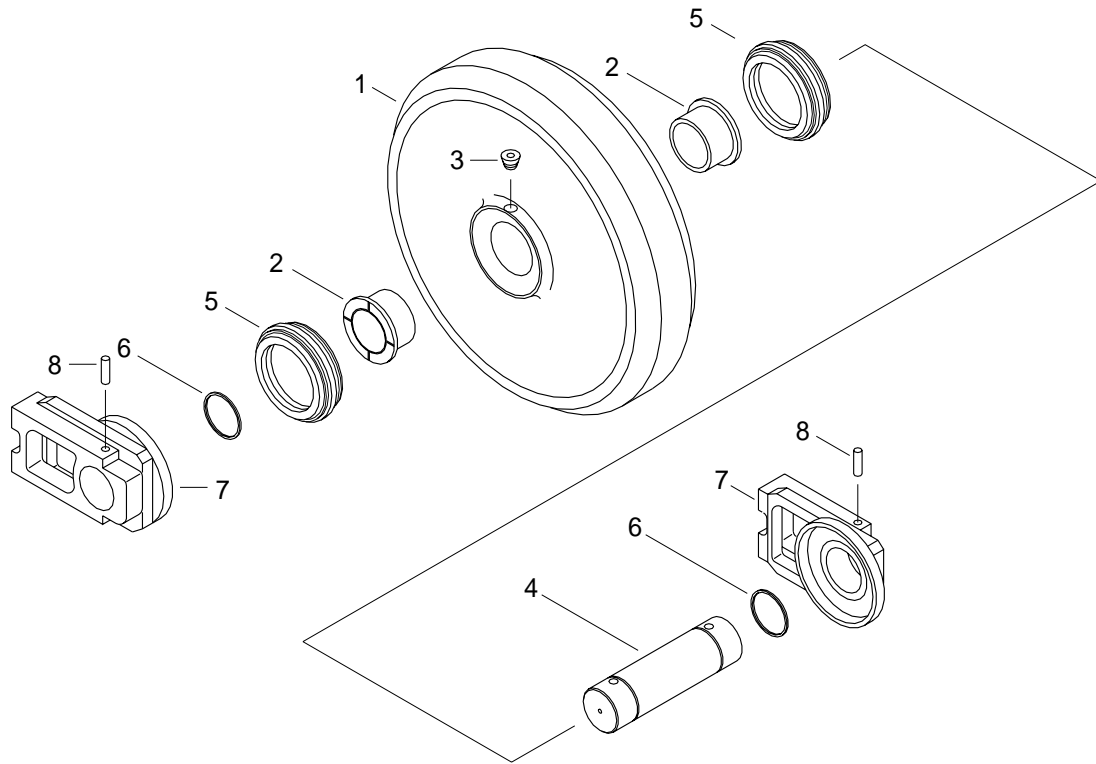

- 1 Idler
- 2 Bushing
- 3 Plug

- 4 Shaft
- 5 Seal assembly
- 6 O-ring

- 7 O-ring
- 8 Bracket
- 9 Dowel pin

(2) Disassembly

- ① Remove plug and drain oil.
- ② Draw out the dowel pin(8), using a press.

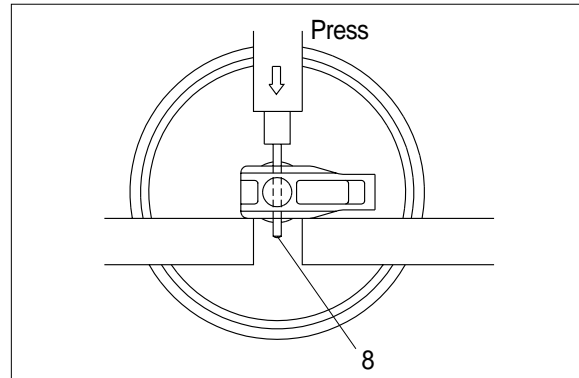

- ③ Pull out the shaft(4) with a press.
- ④ Remove seal assembly(5) from idler(1) and bracket(8).
- ⑤ Remove O-ring(6) from shaft.

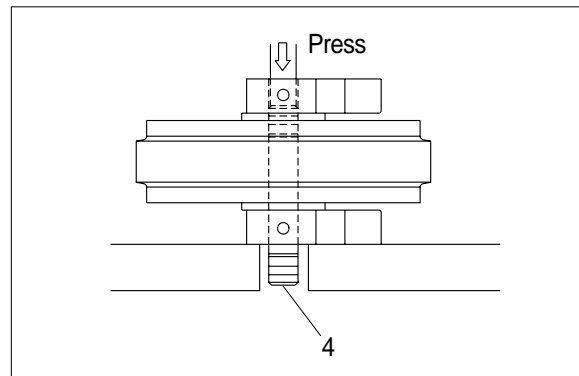

- ⑥ Remove the bushing(2) from idler, using a special tool.
- ※ Only remove bushing if replacement is necessary.

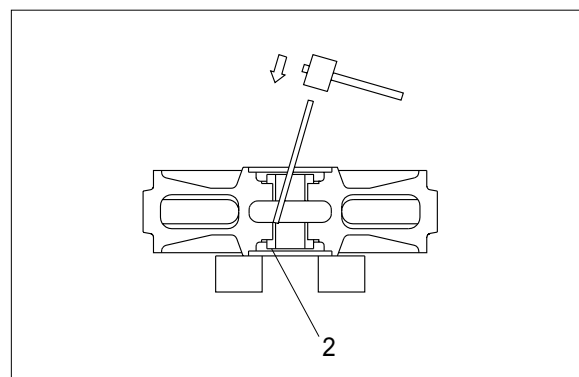

(3) Assembly

- ※ Before assembly, clean the parts.
- ※ Coat the sliding surfaces of all parts with oil.

- ① Cool up bushing(2) fully by some dry ice and press it into shell(1).
Do not press it at the normal temperature, or not knock in with a hammer even after the cooling.

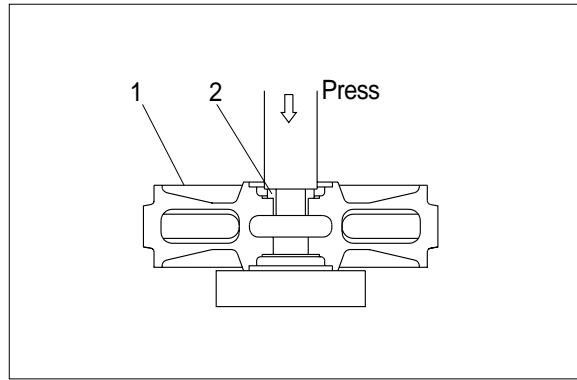

- ② Coat O-ring(6) with grease thinly, and install it to shaft(4).
③ Insert shaft(4) into bracket(7), and drive in the dowel pin(8).

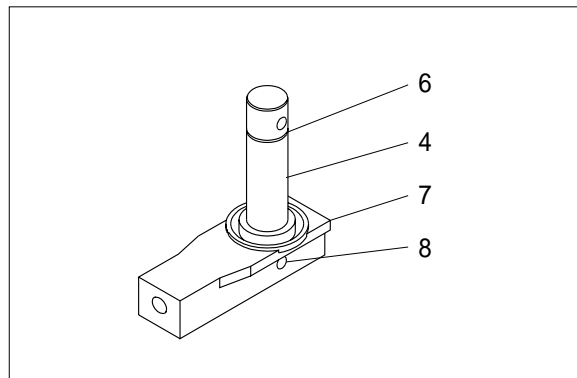

- ④ Install seal assembly(5) to idler(1) and bracket(7).

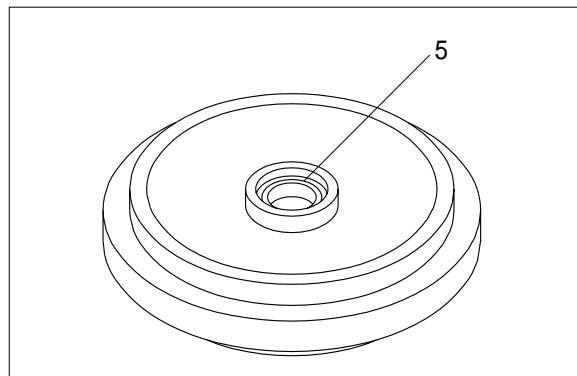

- ⑤ Install shaft(4) to idler(1).

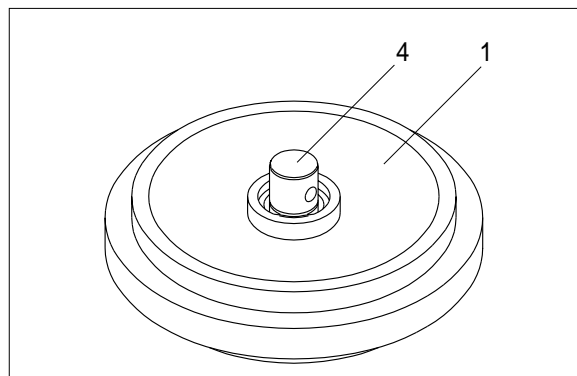

- ⑥ Install bracket(7) attached with seal assembly(5).

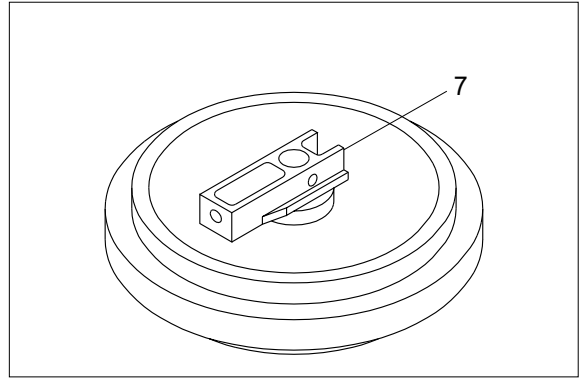

- ⑦ Knock in the dowel pin(8) with a hammer.

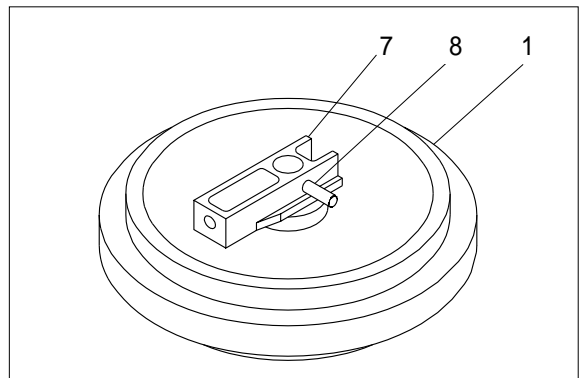

- ⑧ Lay bracket(7) on its side.
Supply engine oil to the specified level,
and tighten plug.

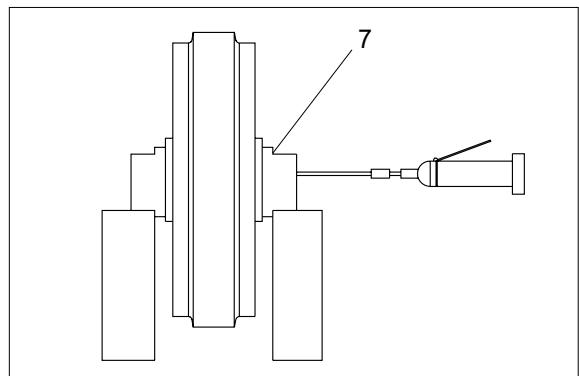

4) DISASSEMBLY AND ASSEMBLY OF RECOIL SPRING

(1) Structure

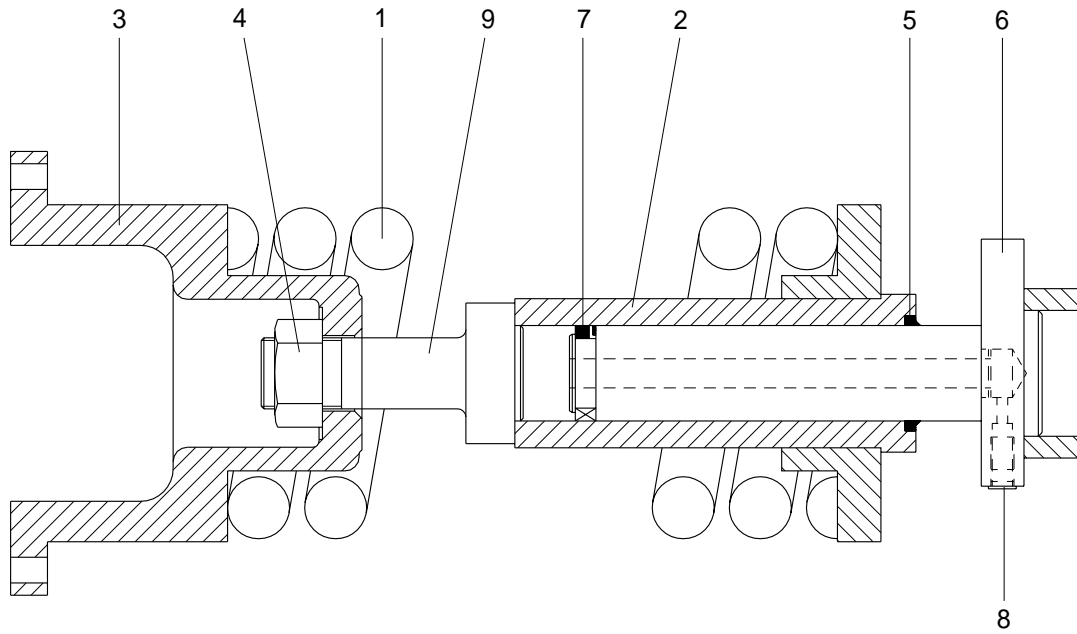

1 Spring
2 Cylinder
3 Fork

4 Nut
5 Packing
6 Piston

7 Packing
8 Plug
9 Tie rod

(2) Disassembly

- ① Apply pressure on spring(1) with a press.
 - ※ The spring is under a large installed load. This is dangerous, so be sure to set properly.
Spring set load : 11000kg(24250lb)
- ② Remove lock nut(4).
- ※ Take enough notice so that the press which pushes down the spring, should not be slipped out in its operation.
- ③ Lighten the press load slowly, and remove fork(3) and spring(1).

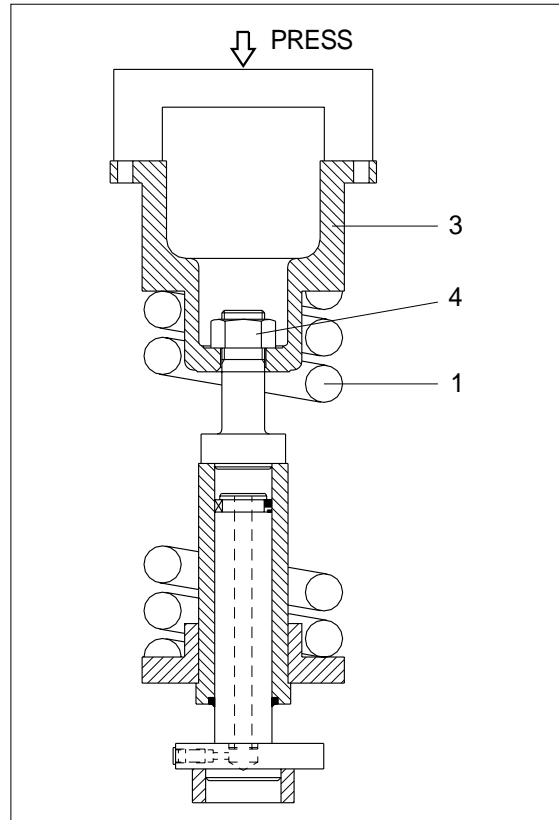

- ④ Remove piston(6) from cylinder liner(2).
- ⑤ Remove plug(8) from piston(6).

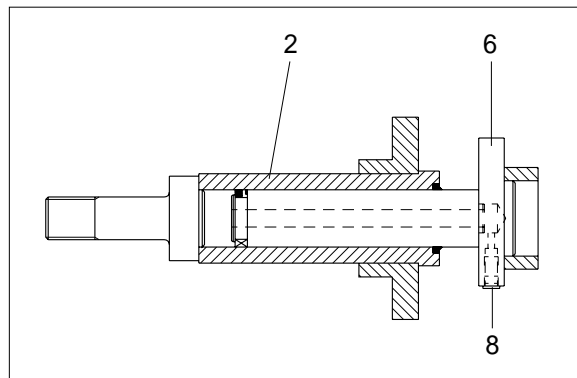

- ⑥ Remove packings(5,7).

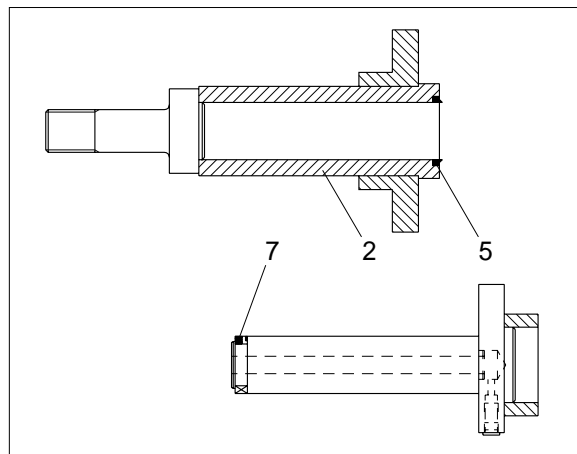

(3) Assembly

- ① Install packings(5,7) to cylinder liner(2).
- ※ When installing packing(5,7) take full care so as not to damage the lip.

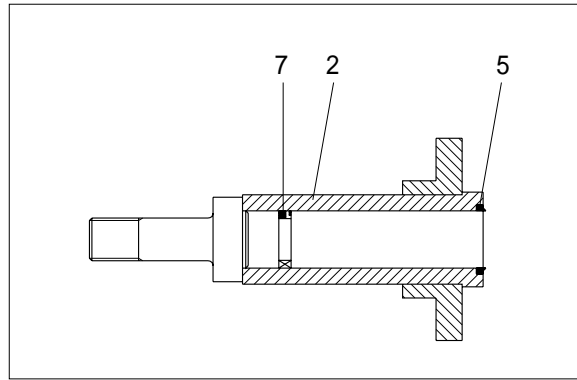

- ② Pour grease into cylinder liner(2), then push in piston(6) by hand.
After take grease out of plug mounting hole, let air out.
- ※ If air letting is not sufficient, it may be difficult to adjust the tension of crawler.
- ③ Fit plug(8) to piston(6).
Tightening torque : $10 \pm 1 \text{ kg} \cdot \text{m}$
 $(72.3 \pm 7.2 \text{ lb} \cdot \text{ft})$

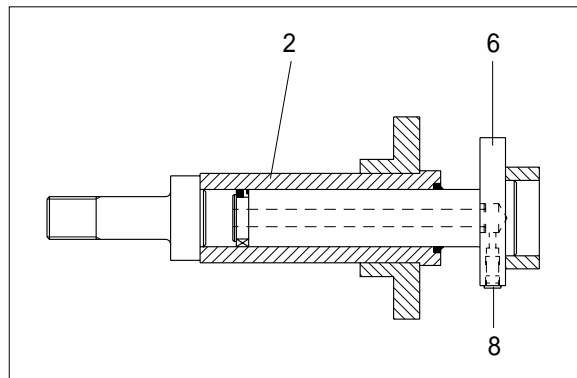

- ④ Install spring(1) and fork(3) to cylinder liner(2).
- ⑤ Apply pressure to spring(1) with a press and tighten lock nut(4).
- ※ Apply sealant before assembling.
- ※ During the operation, pay attention specially to prevent the press from slipping out.
- ⑥ Lighten the press load and confirm the set length of spring(1).

