

# GROUP 2 SPECIFICATION

## 1. MAJOR COMPONENTS

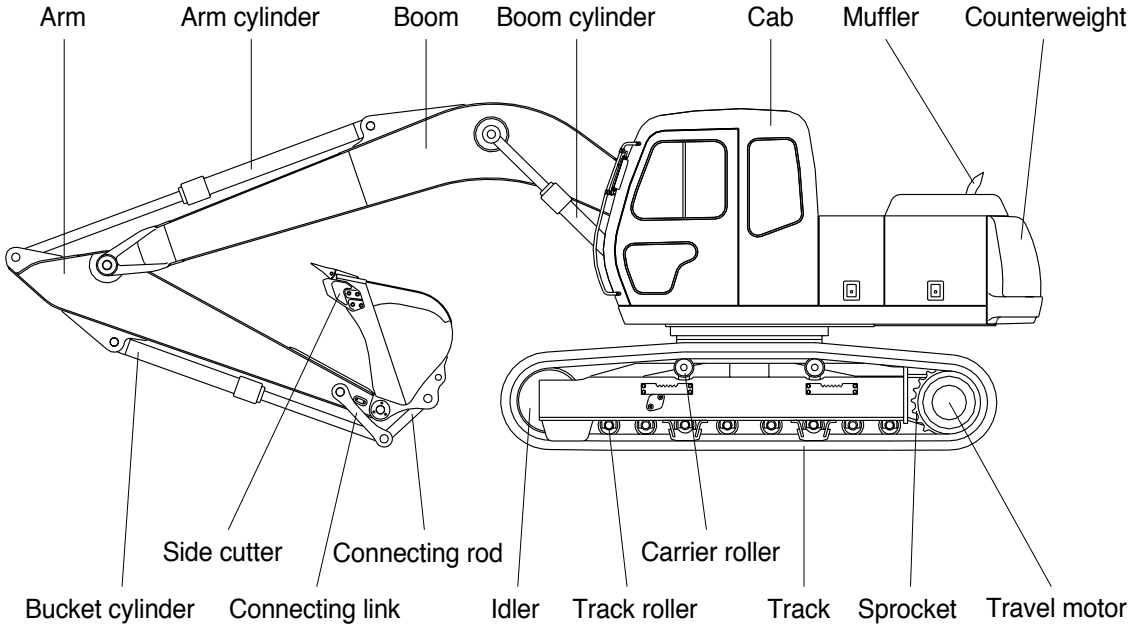
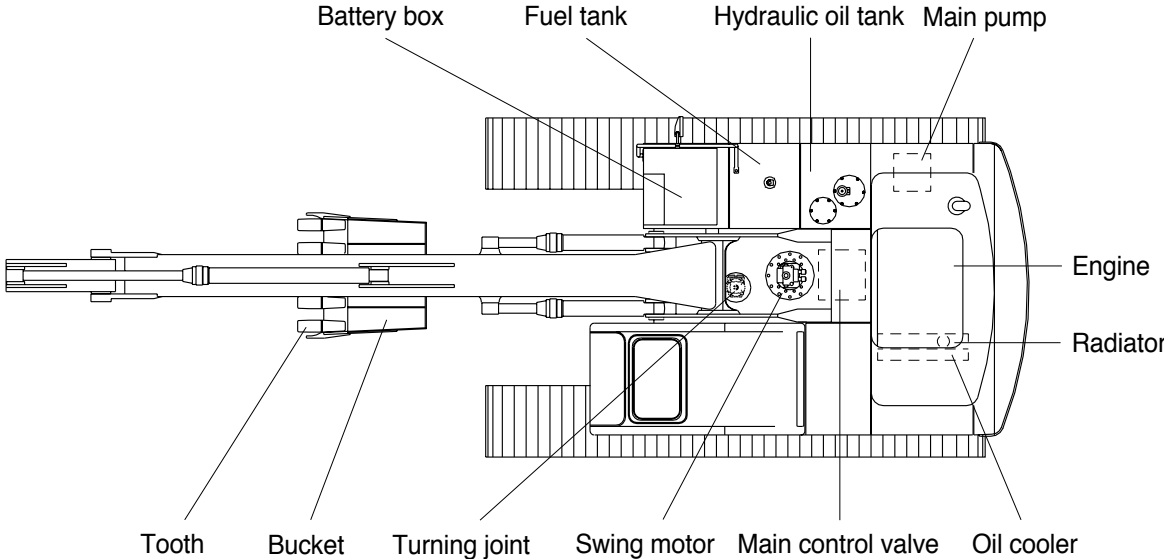

## 2. SPECIFICATIONS

### 1) 5.2m(17'1") ONE PIECE BOOM AND 2.6m(8'6") ARM

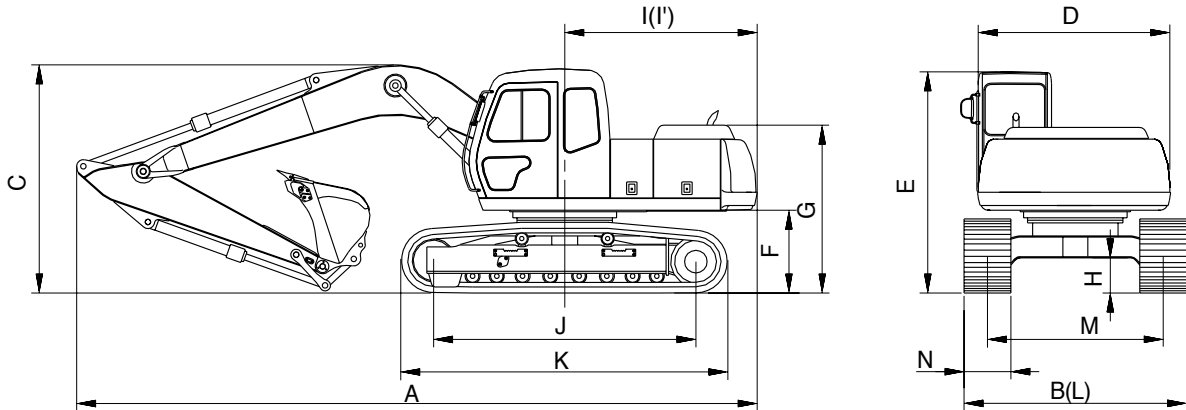

Description	Unit	Specification
Operating weight	kg(lb)	17800(39240)
Bucket capacity(PCSA heaped), standard	m <sup>3</sup> (yd <sup>3</sup> )	0.70(0.92)
Overall length	A	8720(28' 7")
Overall width, with 600mm shoe	B	2850( 9' 4")
Overall height	C	2970( 9' 9")
Superstructure width	D	2450( 8' 0")
Cab height	E	2870( 9' 5")
Ground clearance of counterweight	F	1050( 3' 5")
Engine cover height	G	2110( 6' 11")
Minimum ground clearance	H	450( 1' 6")
Rear-end distance	I	2450( 8' 0")
Rear-end swing radius	I'	2530( 8' 4")
Distance between tumblers	J	3360(11' 0")
Undercarriage length	K	4150(13' 7")
Undercarriage width	L	2850( 9' 4")
Track gauge	M	2250( 7' 5")
Track shoe width, standard	N	600(24")
Travel speed(low/high)	km/hr(mph)	3.2/5.2(2.0/3.2)
Swing speed	rpm	11.5
Gradeability	Degree(%)	35(70)
Ground pressure(600mm shoe)	kg/cm <sup>2</sup> (psi)	0.41(5.83)

2) 5.0m(16'5") TWO PIECE BOOM(CYL TYPE) AND 2.2m(7'3") ARM

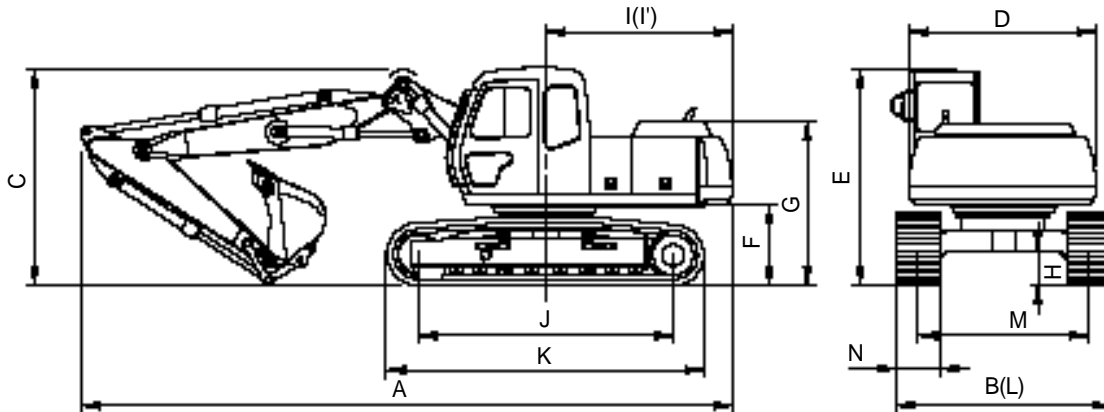

Description		Unit	Specification
Operating weight		kg(lb)	18270(40280)
Bucket capacity(PCSA heaped), standard		m <sup>3</sup> (yd <sup>3</sup> )	0.70(0.92)
Overall length	A	mm(ft-in)	8500(27' 11")
Overall width, with 600mm shoe	B		2850( 9' 4")
Overall height	C		2770( 9' 1")
Superstructure width	D		2450( 8' 0")
Cab height	E		2870( 9' 5")
Ground clearance of counterweight	F		1050( 3' 5")
Engine cover height	G		2110( 6' 11")
Minimum ground clearance	H		450( 1' 6")
Rear-end distance	I		2450( 8' 0")
Rear-end swing radius	I'		2530( 8' 4")
Distance between tumblers	J		3360(11' 0")
Undercarriage length	K		4150(13' 7")
Undercarriage width	L		2850( 9' 4")
Track gauge	M		2250( 7' 5")
Track shoe width, standard	N		600(24")
Travel speed(low/high)		km/hr(mph)	3.2/5.2(2.0/3.2)
Swing speed		rpm	11.5
Gradeability		Degree(%)	35(70)
Ground pressure(600mm shoe)		kg/cm <sup>2</sup> (psi)	0.42(5.97)

### 3. WORKING RANGE

#### 1) 5.2m(17'1") ONE PIECE BOOM

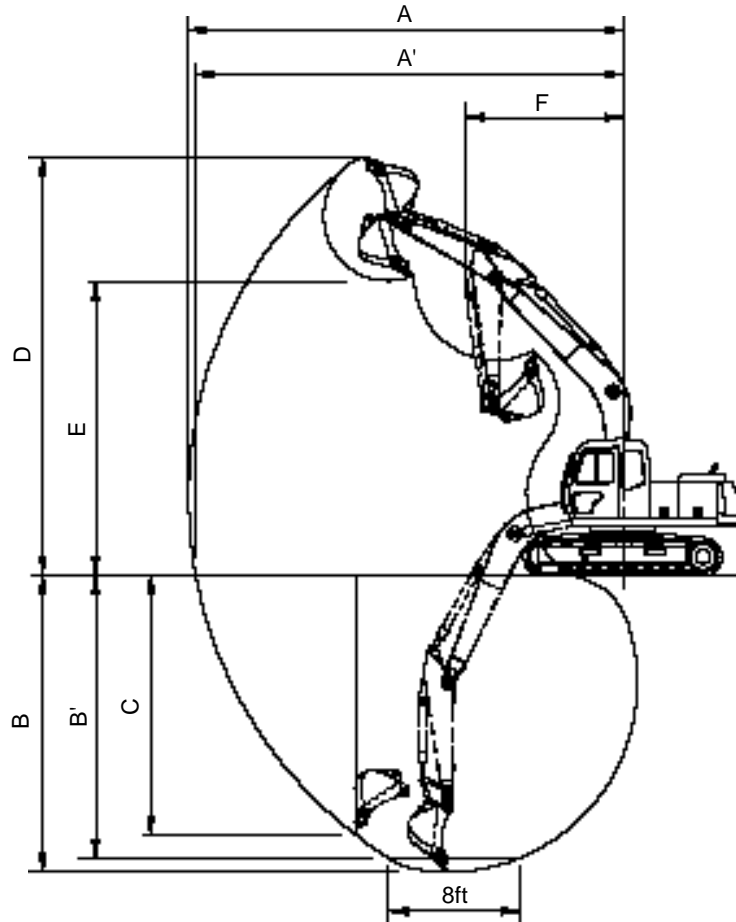

Description		1.85m(6' 1") Arm	2.2m(7' 2") Arm	2.6m(8' 6") Arm	3.2m(10' 6") Arm
Max. digging reach	A	8410mm (27' 7")	8740mm (28' 8")	9100mm (29'10")	9690mm (31' 9")
Max. digging reach on ground	A'	8250mm (27' 1")	8590mm (28' 2")	8950mm (29' 4")	9550mm (31' 4")
Max. digging depth	B	5490mm (18' 0")	5840mm (19' 2")	6240mm (20' 6")	6840mm (22' 5")
Max. digging depth (8ft level)	B'	5200mm (17' 1")	5590mm (18' 4")	6010mm (19' 9")	6660mm (21' 10")
Max. vertical wall digging depth	C	4630mm (15' 2")	5150mm (16'11")	5420mm (17' 9")	6370mm (20' 11")
Max. digging height	D	8360mm (27' 5")	8580mm (28' 2")	8740mm (28' 8")	9140mm (30' 0")
Max. dumping height	E	5770mm (18'11")	5970mm (19' 7")	6140mm (20' 2")	6510mm (23' 5")
Min. swing radius	F	3510mm (11' 6")	3310mm (10'10")	3310mm (10'10")	3390mm (11' 1")
Bucket digging force		105.2[115] kN	105.2[115] kN	105.2[115] kN	105.2[115] kN
		10730[11730] kgf	10730[11730] kgf	10730[11730] kgf	10730[11730] kgf
		23650[25860] lbf	23650[25860] lbf	23650[25860] lbf	23650[25860] lbf
Arm digging force		95.4[104.3] kN	78.6[85.9] kN	69.6[76.1] kN	61.3[67.0] kN
		9730[10640] kgf	8010[8760] kgf	7100[7760] kgf	6250[6830] kgf
		21450[23450] lbf	17660[19310] lbf	15650[17110] lbf	13780[15070] lbf

[ ] : Power boost

2) 5.0m(16'5") TWO PIECE BOOM(CYL TYPE)

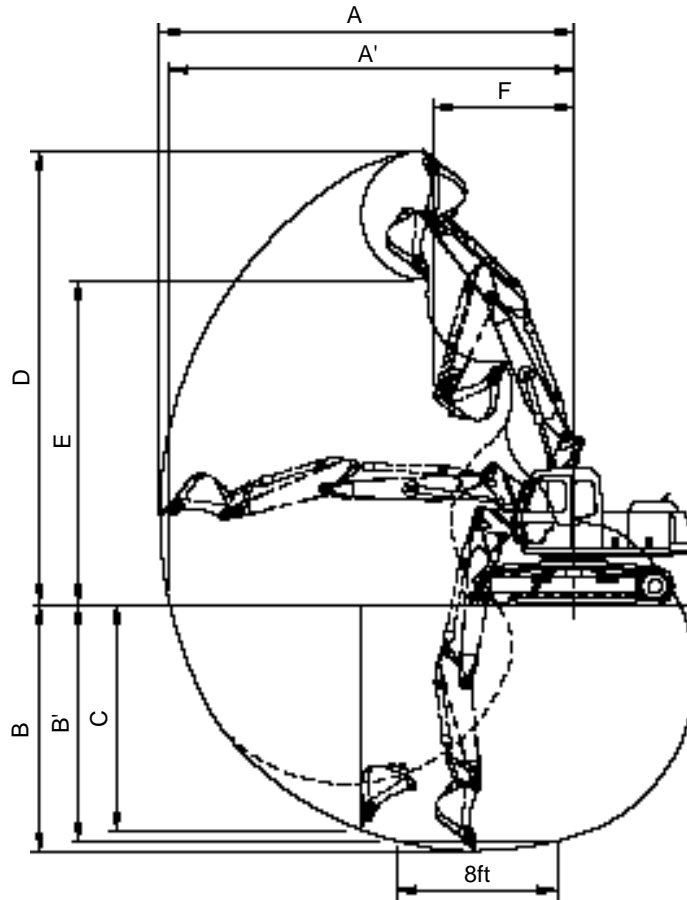

Description		1.85m(6' 1") Arm	2.2m(7' 3") Arm
Max. digging reach	A	8370mm (27' 6")	8680mm (28' 6")
Max. digging reach on ground	A'	8210mm (26'11")	8520mm (27'11")
Max. digging depth	B	5070mm (16' 8")	5430mm (17'10")
Max. digging depth (8ft level)	B'	4950mm (16' 3")	5300mm (17' 5")
Max. vertical wall digging depth	C	3680mm (12' 1")	4030mm (13' 3")
Max. digging height	D	9280mm (30' 5")	9470mm (31' 1")
Max. dumping height	E	6560mm (21' 6")	6750mm (22' 2")
Min. swing radius	F	3180mm (10' 5")	2960mm ( 9' 9")
Bucket digging force		105.2[115] kN	105.2[115] kN
		10730[11730] kgf	10730[11730] kgf
		23650[25860] lbf	23650[25860] lbf
Arm digging force		95.4[104.3] kN	78.6[85.9] kN
		9730[10640] kgf	8010[8760] kgf
		21450[23450] lbf	17660[19310] lbf

[ ] : Power boost

#### 4. WEIGHT













Item	R180LC-3	
	kg	lb
Upperstructure assembly	7450	16420
Main frame weld assembly	1254	2760
Engine assembly	423	930
Main pump assembly	80	180
Main control valve assembly	135	300
Swing motor assembly	190	420
Hydraulic oil tank assembly	210	460
Fuel tank assembly	115	250
Counterweight	2950	6500
Cab assembly	275	610
Lower chassis assembly	7350	16200
Lower frame weld assembly	2506	5520
Swing bearing	260	570
Travel motor assembly	187	410
Turning joint	40	90
Track recoil spring and idler	270	600
Idler	168	370
Carrier roller	21	50
Track roller	38	80
Track-chain assembly(600mm triple grouser shoe)	1340	2950
Front attachment assembly(5.2m boom, 2.6m arm, 0.7m³ PCSA heaped bucket)	3000	6610
5.2m one piece boom assembly	1064	2350
5.0m two piece boom assembly	1534	3380
2.6m arm assembly	540	1190
0.7m³ CECE heaped bucket assembly	540	1190
Boom cylinder assembly	145	320
Arm cylinder assembly	183	400
Bucket cylinder assembly	135	300
Bucket control link assembly	145	320
2.2m arm assembly	469	1030

## 5. LIFTING CAPACITIES

### 1) ROBEX 180LC-3









(1) 5.20m(17' 1") boom, 2.60m(8' 6") arm equipped with 0.70m<sup>3</sup>(PCSA heaped) bucket and 600mm (24") triple grouser shoe.

-  : Rating over-front
-  : Rating over-side or 360 degree











Load point height		Load radius										At max. reach			
		1.5m(5ft)		3.0m(10ft)		4.5m(15ft)		6.0m(20ft)		7.5m(25ft)		Capacity		Reach	
														m(ft)	
7.5m (25ft)	kg lb												*2820 *6220	*2820 *6220	6.40 (21.0)
6.0m (20ft)	kg lb						*2780 *6130	*2780 *6130					*2830 *6240	2190 4830	7.63 (25.0)
4.5m (15ft)	kg lb						*3250 *7170	*3250 *7170					*2890 *6370	1790 3950	8.35 (27.4)
3.0m (10ft)	kg lb			*7040 *15520	*7040 *15520	*4650 *10250	*4650 *10250	*3740 *8250	3090 6810	*2730 *6020	2080 4590	2710 5970	1600 3530	8.71 (28.6)	
1.5m (5ft)	kg lb			*6590 *14530	*6590 *14530	*5870 *12940	4570 10080	*4310 *9500	2910 6420	3370 7430	2000 4410	2640 5820	1540 3400	8.75 (28.7)	
Ground Line	kg lb			*6710 *14790	*6710 *14790	*6650 *14660	4300 9480	4700 10360	2760 6080	3300 7280	1930 4250	2740 6040	1600 3530	8.50 (27.9)	
-1.5m (-5ft)	kg lb	*5910 *13030	*5910 *13030	*9180 *20240	8240 18170	*6800 *14990	4190 9240	4620 10190	2690 5930			3070 6770	1800 3970	7.90 (27.9)	
-3.0m (-10ft)	kg lb	*8750 *19290	*8750 *19290	*9330 *20570	8360 18430	*6290 *13870	4220 9300	*4440 *9790	2710 5970			*3300 *7280	2310 5090	6.86 (22.5)	
-4.5m (-15ft)	kg lb			*7040 *15520	*7040 *15520	*4730 *10430	4390 9680								
-9.0m (-30ft)	kg lb											*1840 *4060	1780 3920	9.26 (30.4)	

- Note
1. Lifting capacity are based on SAE J1097 and ISO 10567.
  2. Lifting capacity of the ROBEX series does not exceed 75% of tipping load with the machine on firm, level ground or 87% of full hydraulic capacity.
  3. The load point is a hook located on the back of the bucket.
  4. \*indicates load limited by hydraulic capacity.

(2) 5.20m(17' 1") boom, 1.85m(6' 1") arm equipped with 0.70m<sup>3</sup>(PCSA heaped) bucket and 600mm (24") triple grouser shoe.













Load point height		Load radius						At max. reach		
		3.0m(10ft)		4.5m(15ft)		6.0m(20ft)		Capacity		Reach
										m(ft)
7.5m (25ft)	kg lb							*3330 *7340	*3330 *7340	5.33 (17.5)
6.0m (20ft)	kg lb							*3270 *7210	2670 5890	6.80 (22.3)
4.5m (15ft)	kg lb			*4300 *9480	*4300 *9480	*3780 *8330	3180 7010	*3320 *7320	2120 4670	7.61 (25.0)
3.0m (10ft)	kg lb			*5400 *11900	4830 10650	*4190 *9240	3040 6700	3120 6880	1870 4120	8.01 (26.3)
1.5m (5ft)	kg lb			*6430 *14180	4480 9880	*4660 *10270	2890 6370	3030 6680	1800 3970	8.06 (26.4)
Ground Line	kg lb			*6890 *15190	4300 9480	4720 10410	2780 6130	3190 7030	1890 4170	7.78 (25.5)
-1.5m (-5ft)	kg lb	*9680 *21340	8420 18560	*6700 *14770	4260 9390	4690 10340	2760 6080	*3640 *8020	2200 4850	7.11 (23.3)
-3.0m (-10ft)	kg lb	*8160 *17990	*8160 *17990	*5760 *12700	4350 9590			*3410 *7520	3030 6680	5.90 (19.4)

(3) 5.20m(17' 1") boom, 2.20m(7' 3") arm equipped with 0.70m<sup>3</sup>(PCSA heaped) bucket and 600mm (24") triple grouser shoe.









Load point height		Load radius								At max. reach		
		1.5m(5ft)		3.0m(10ft)		4.5m(15ft)		6.0m(20ft)		Capacity		Reach
												m(ft)
7.5m (25ft)	kg lb									*3110 *6860	*3100 *6860	5.87 (19.3)
6.0m (20ft)	kg lb						*2630 *5800	*2630 *5800	*3090 *6810	2440 5380		7.21 (23.7)
4.5m (15ft)	kg lb						*3560 *7850	3240 7140	*3140 *6920	1970 4340		7.97 (26.1)
3.0m (10ft)	kg lb			*8130 *17920	*8130 *17920	*5090 *11220	4940 10890	*4020 *8860	3100 6830	2940 6480	1760 3880	8.35 (27.4)
1.5m (5ft)	kg lb					*6230 *13730	4560 10050	*4550 *10030	2940 6480	2860 6310	1700 3750	8.40 (27.6)
Ground Line	kg lb			*6190 *13650	*6190 *13650	*6850 *15100	4340 9570	4750 10470	2810 6190	2990 6590	1770 3900	8.13 (26.7)
-1.5m (-5ft)	kg lb	*6340 *13980	*6340 *13980	*9710 *21410	8390 18500	*6820 *15040	4280 9440	4700 10360	2760 6080	3390 7470	2020 4450	7.50 (24.6)
-3.0m (-10ft)	kg lb	*9890 *21800	*9890 *21800	*8830 *19470	8550 18850	*6110 *13470	4330 9550			*3400 *7500	2680 5910	6.38 (20.9)
-4.5m (-15ft)	kg lb			*6130 *13510	*6130 *13510							
-9.0m (-30ft)	kg lb									*1800 *3970	1760 3880	9.58 (31.4)













(4) 5.20m(17' 1") boom, 3.20m(10' 6") arm equipped with 0.70m<sup>3</sup>(PCSA heaped) bucket and 600mm (24") triple grouser shoe.

Load point height		Load radius										At max. reach		
		1.5m(5ft)		3.0m(10ft)		4.5m(15ft)		6.0m(20ft)		7.5m(25ft)		Capacity		Reach
														m(ft)
7.5m (25ft)	kg lb							*1810 *3990	*1810 *3990			*2470 *5450	2460 5420	7.23 (23.7)
6.0m (20ft)	kg lb											*2500 *5510	1840 4060	8.31 (27.3)
4.5m (15ft)	kg lb							*2760 *6080	*2760 *6080	*2270 *5000	2150 4740	*2570 *5670	1530 3370	8.97 (29.4)
3.0m (10ft)	kg lb					*3940 *8690	*3940 *8690	*3290 *7250	3120 6880	*2950 *6500	2070 4560	2390 5270	1370 3020	9.30 (30.5)
1.5m (5ft)	kg lb			*8800 *19400	*8800 *19400	*5270 *11620	4650 10250	*3940 *8690	2910 6420	*3280 *7230	1970 4340	2320 5110	1320 2910	9.34 (30.6)
Ground Line	kg lb			*7040 *15520	*7040 *15520	*6280 *13850	4300 9480	*4490 *9900	2740 6040	3250 7170	1880 4140	2390 5270	1360 3000	9.11 (29.9)
-1.5m (-5ft)	kg lb	*5110 *11270	*5110 *11270	*8400 *18520	8100 17880	*6710 *14790	4130 9110	4560 10050	2630 5800	3190 7030	1830 4030	2640 5820	1510 3330	8.56 (28.1)
-3.0m (-10ft)	kg lb	*7380 *16270	*7380 *16270	*9950 *21940	8160 17990	*6500 *14330	4100 9040	4540 10010	2600 5730			*3030 *6680	1870 4120	7.63 (25.0)
-4.5m (-15ft)	kg lb	*10380 *22880	*10380 *22880	*8230 *18140	*8230 *18140	*5500 *12130	4200 9260					*2860 *6310	2800 6170	6.10 (20.0)
-9.0m (-30ft)	kg lb											*1830 *4030	*1830 *4030	8.67 (28.4)





(5) 5.0m two piece boom(cyl type), 1.85m(6' 1") arm equipped with 0.70m<sup>3</sup>(PCSA heaped) bucket and 600mm (24") triple grouser shoe.

Load point height		Load radius						At max. reach		
		1.5m(5ft)		3.0m(10ft)		4.5m(15ft)		Capacity		Reach
										m(ft)
1.5m (5ft)	kg lb							*2540 *5600	*2540 *5600	6.17 (20.2)
Ground Line	kg lb	*9520 *20990	*9520 *20990	*6170 *13600	*6170 *13600	*3940 *8690	*3940 *8690	*3920 *8640	3400 7500	5.77 (18.9)
-1.5m (-5ft)	kg lb	*15800 *34830	*15800 *34830	*9180 *20240	*9180 *20240			*6280 *13850	4530 9990	4.75 (15.6)
-3.0m (-10ft)	kg lb	*25820 *56920	*25820 *56920							

(6) 5.0m two piece boom(cyl type), 2.2m(7' 3") arm equipped with 0.70m<sup>3</sup>(PCSA heaped) bucket and 600mm(24") triple grouser shoe.

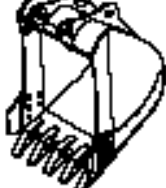

Load point height		Load radius								At max. reach		
		3.0m(10ft)		4.5m(15ft)		6.0m(20ft)		7.5m(25ft)		Capacity		Reach
												m(ft)
10.5m (35ft)	kg lb									*2590 *5710	*2590 *5710	5.87 (19.3)
7.5m (25ft)	kg lb			*3250 *7170	*3250 *7170					*3130 *6900	*3130 *6900	5.76 (18.9)
6.0m (20ft)	kg lb			*3250 *7170	*3250 *7170	*2840 *6260	*2840 *6260			*3050 *6720	2430 5360	7.13 (23.4)
4.5m (15ft)	kg lb			*3740 *8250	*3740 *8250	*3410 *7520	3210 7080			*2770 *6110	1960 4320	7.90 (25.9)
3.0m (10ft)	kg lb			*4750 *10470	*4750 *10470	*3770 *8310	3070 6770			*2620 *5780	1750 3860	8.28 (27.2)
1.5m (5ft)	kg lb			*5350 *11790	4540 10010	*3820 *8420	2910 6420	*2810 *6190	1990 4390	*2610 *5750	1700 3750	8.33 (27.3)
Ground Line	kg lb	*5730 *12630	*5730 *12630	*5450 *12020	4310 9500	*3870 *8530	2790 6150			*2760 *6080	1790 3950	8.06 (26.4)
-1.5m (-5ft)	kg lb	*8880 *19580	8360 18430	*5520 *12170	4260 9390	*3930 *8660	2750 6060			*3100 *6830	2070 4560	7.42 (24.3)

## 6. BUCKET SELECTION GUIDE

				
0.45m <sup>3</sup> PCSA heaped bucket	0.57m <sup>3</sup> PCSA heaped bucket	0.70m <sup>3</sup> PCSA heaped bucket	0.80m <sup>3</sup> PCSA heaped bucket	1.03m <sup>3</sup> PCSA heaped bucket

Capacity		Width		Weight	Recommendation						
PCSA heaped	CECE heaped	Without side cutter	With side cutter		5.2m (17' 1") one piece boom				*5.0m (16' 5") boom		
					1.85m arm (6' 1")	2.2m arm (7' 3")	2.6m arm (8' 6")	3.2m arm (10' 6")	1.85m arm (6' 1")	2.2m arm (7' 3")	
0.45m <sup>3</sup> (0.59yd <sup>3</sup> )	0.35m <sup>3</sup> (0.46yd <sup>3</sup> )	620mm (24.4")	740mm (29.1")	410kg (900lb)							
0.57m <sup>3</sup> (0.75yd <sup>3</sup> )	0.50m <sup>3</sup> (0.65yd <sup>3</sup> )	840mm (33.1")	960mm (37.8")	490kg (1080lb)							
0.70m <sup>3</sup> (0.92yd <sup>3</sup> )	0.60m <sup>3</sup> (0.78yd <sup>3</sup> )	990mm (39.0")	1110mm (43.7")	540kg (1190lb)							
0.80m <sup>3</sup> (1.05yd <sup>3</sup> )	0.70m <sup>3</sup> (0.92yd <sup>3</sup> )	1080mm (42.5")	1200mm (47.2")	570kg (1260lb)							
1.03m <sup>3</sup> (1.35yd <sup>3</sup> )	0.90m <sup>3</sup> (1.18yd <sup>3</sup> )	1400mm (55.1")	1520mm (59.8")	650kg (1430lb)							

\*: Two piece boom

-  Applicable for materials with density of 2000kg/m<sup>3</sup>(3370lb/yd<sup>3</sup>) or less
-  Applicable for materials with density of 1600kg/m<sup>3</sup>(2700lb/yd<sup>3</sup>) or less
-  Applicable for materials with density of 1100kg/m<sup>3</sup>(1850lb/yd<sup>3</sup>) or less

## 7. UNDERCARRIAGE

### 1) TRACKS

X-leg type center frame is integrally welded with reinforced box-section track frames. The design includes dry tracks, lubricated rollers, idlers, sprockets, hydraulic track adjusters with shock absorbing springs, and assembled track-type tractor shoes with triple grousers.

### 2) TYPES OF SHOES

Shapes		Triple grouser		
				
Shoe width	mm(in)	600(24)	700(28)	800(32)
Operating weight	kg(lb)	17800(39240)	18060(39820)	18320(40390)
Ground pressure	kg/cm <sup>2</sup> (psi)	0.41(5.83)	0.35(4.98)	0.31(4.41)
Overall width	mm(ft-in)	2850(9' 4")	2950(9' 8")	3050(10' 0")

### 3) NUMBER OF ROLLERS AND SHOES ON EACH SIDE

Item	Quantity
Carrier rollers	2EA
Track rollers	8EA
Track shoes	51EA

## 8. SPECIFICATIONS FOR MAJOR COMPONENTS

### 1) ENGINE

Item	Specification
Model	Cummins 6BT5.9-C
Type	4-cycle turbocharged diesel engine
Cooling method	Water cooling
Number of cylinders and arrangement	6 cylinders, in-line
Firing order	1-5-3-6-2-4
Combustion chamber type	Direct injection type
Cylinder bore × stroke	102 × 120mm(4.02" × 4.72")
Piston displacement	5880cc(359cu in)
Compression ratio	17.5 : 1
Rated gross horse power	126Hp at 2100rpm(94 kW at 2100rpm)
Maximum torque at 1300rpm	53kgf · m(383lb · ft)
Engine oil quantity	11 l (2.9U.S. gal)
Dry weight	399kg(880lb)
High idling speed	2250+50rpm
Low idling speed	800 ± 100rpm
Rated fuel consumption	158g/Hp · hr
Starting motor	Delco Remy 37MT(24V)
Alternator	DAC HC60(24V-60Amp)
Battery	2 × 12V × 160Ah

### 2) MAIN PUMP

Item	Specification	
Type	Variable displacement bent axis piston pump	
Capacity	2 × 80cc/rev	
Pressure	Rated	320kg/cm <sup>2</sup> (4550psi)
	Maximum(power boost)	350kg/cm <sup>2</sup> (4978psi)
Rated oil flow	2 × 165 l /min (43.6U.S. gpm/ 36.3U.K. gpm)	
Rated speed	2100rpm (clockwise viewed from shaft end)	

### 3) GEAR PUMP

Item	Specification
Type	Fixed displacement gear pump single stage
Capacity	11.4cc/rev
Maximum pressure	40 <sup>+2</sup> <sub>0</sub> kg/cm <sup>2</sup> (570psi)
Rated oil flow	30 l /min(7.93U.S. gpm/6.6U.K. gpm)

### 4) MAIN CONTROL VALVE

Item	Specification
Type	9 spool
Operating method	Hydraulic pilot system
Main relief valve pressure	320kg/cm <sup>2</sup> (4550psi) / [350kg/cm <sup>2</sup> (4980psi)]
Overload relief valve pressure	380kg/cm <sup>2</sup> (5400psi)

[ ] : Power boost

### 5) SWING MOTOR

Item	Specification
Type	Fixed displacement axial piston motor
Capacity	151cc/rev
Relief pressure	240kg/cm <sup>2</sup> (3410psi)
Braking system	Automatic, spring applied hydraulic released
Braking torque	27kg · m(195lb · ft)
Brake release pressure	20~50kg/cm <sup>2</sup> (285~710psi)
Reduction gear type	2 - stage planetary
Swing speed	11.5rpm

### 6) TRAVEL MOTOR

Item	Specification
Type	Variable displacement axial piston motor
Capacity	80kg/cm <sup>2</sup> (1138psi)
Relief pressure	335kg/cm <sup>2</sup> (4765psi)
Reduction gear type	3-stage planetary
Braking system	Automatic, spring applied hydraulic released
Brake release pressure	30kg/cm <sup>2</sup> (427psi)
Brake torque	3473kg · m(25120lb · ft)

## 7) REMOTE CONTROL VALVE

Item		Specification
Type		Pressure reducing type
Operating pressure	Minimum	5kg/cm <sup>2</sup> (71psi)
	Maximum	20kg/cm <sup>2</sup> (284psi)
Single operation stroke	Lever	61mm(2.4in)
	Pedal	123mm(4.84in)

## 8) CYLINDER

Item		Specification
Boom cylinder	Bore dia × Rod dia × Stroke	∅ 115 × ∅ 80 × 1090mm
	Cushion	Extend only
Arm cylinder	Bore dia × Rod dia × Stroke	∅ 120 × ∅ 85 × 1320mm
	Cushion	Extend and retract
Bucket cylinder	Bore dia × Rod dia × Stroke	∅ 115 × ∅ 80 × 950mm
	Cushion	Extend only

## 9) SHOE

Item	Width	Ground pressure	Link quantity	Overall width
Standard	600mm(24")	0.41kgf/cm <sup>2</sup> (5.83psi)	51	2850mm( 9' 4")
Option	700mm(28")	0.35kgf/cm <sup>2</sup> (4.98psi)	51	2950mm( 9' 8")
	800mm(32")	0.31kgf/cm <sup>2</sup> (4.41psi)	51	3050mm(10' 0")

## 10)BUCKET

Item	Capacity		Tooth quantity	Width	
	PCSA heaped	CECE heaped		Without side cutter	With side cutter
Standard	0.70m <sup>3</sup> (0.92yd <sup>3</sup> )	0.60m <sup>3</sup> (0.78yd <sup>3</sup> )	5	990mm(39.0")	1110mm(43.7")
Option	0.45m <sup>3</sup> (0.59yd <sup>3</sup> )	0.35m <sup>3</sup> (0.46yd <sup>3</sup> )	3	620mm(27.6")	740mm(29.1")
	0.57m <sup>3</sup> (0.75yd <sup>3</sup> )	0.50m <sup>3</sup> (0.65yd <sup>3</sup> )	4	840mm(33.1")	960mm(37.8")
	0.80m <sup>3</sup> (1.05yd <sup>3</sup> )	0.70m <sup>3</sup> (0.92yd <sup>3</sup> )	5	1080mm(42.5")	1200mm(47.2")
	1.03m <sup>3</sup> (1.35yd <sup>3</sup> )	0.90m <sup>3</sup> (1.18yd <sup>3</sup> )	6	1400mm(55.1")	1520mm(59.8")

## 9. RECOMMENDED OILS

Use only oils listed below or equivalent.

Do not mix different brand oil.

Service point	Kind of fluid	Capacity l (U.S. gal)	Ambient temperature °C(°F)								
			-20 (-4)	-10 (14)	0 (32)	10 (50)	20 (68)	30 (86)	40 (104)		
Engine oil pan	Engine oil	16.4(4.3)					SAE 30				
			SAE 10W								
			SAE 10W-30								
			SAE 15W-40								
Swing drive	Gear oil	5.0(1.3)					SAE 85W-140				
Final drive		4.0 × 2 (1.06 × 2)									
Hydraulic tank	Hydraulic oil	Tank; 200(52.8)  System; 270(71.3)	ISO VG 32								
			ISO VG 46								
			ISO VG 68								
Fuel tank	Diesel fuel	250(66.1)	ASTM D975 NO. 1								
			ASTM D975 NO. 2								
Fitting (Grease nipple)	Grease	As required	NLGI NO. 1								
			NLGI NO. 2								
Radiator (Reservoir tank)	Mixture of antifreeze and water 50 : 50	35(9.2)		Ethylene glycol base permanent type							

**SAE** : Society of Automotive Engineers.

**API** : American Petroleum Institute.

**ISO** : International Organization for Standardization.

**NLGI** : National Lubricating Grease Institute.

**ASTM** : American Society of Testing and Material.