

## GROUP 5 POWER BOOST SYSTEM

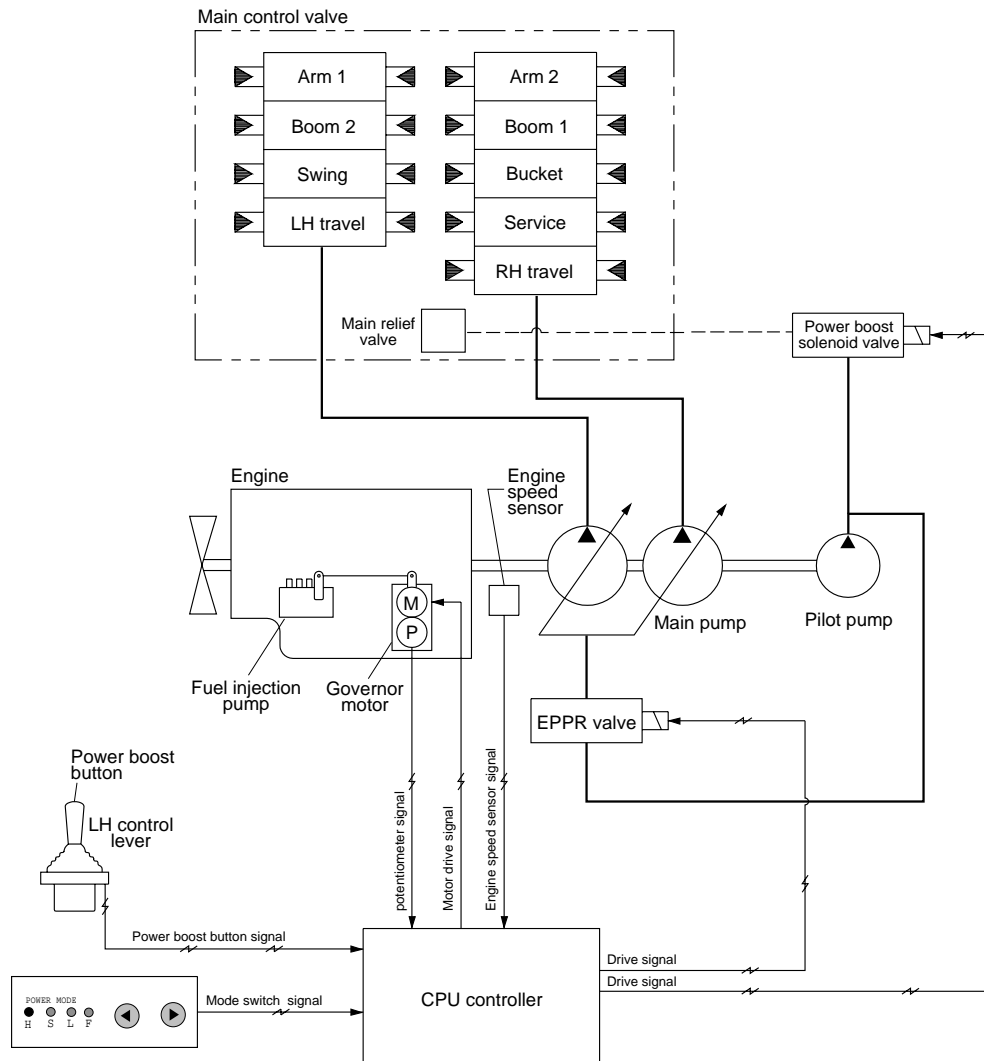

- When the power boost switch on the left control lever knob is pushed ON, the maximum digging power is increased by 10%.
- When the power set is at H or S and the power boost function is activated, the 2-stage relief solenoid valve pilot pressure raises the set pressure of the main relief valve to increase the digging power.

Description	Power boost switch	
	OFF	ON
Power set	H or S	H
Main relief valve set pressure	320kg/cm <sup>2</sup>	350kg/cm <sup>2</sup>
Time of operation	-	Even when pressed continuously, it is canceled after 8 sec.

※ This function does not work when the power mode lamp is at L or F.

※ Default — Power boost solenoid valve : OFF