

SECTION 3 HYDRAULIC SYSTEM

GROUP 1 HYDRAULIC CIRCUIT

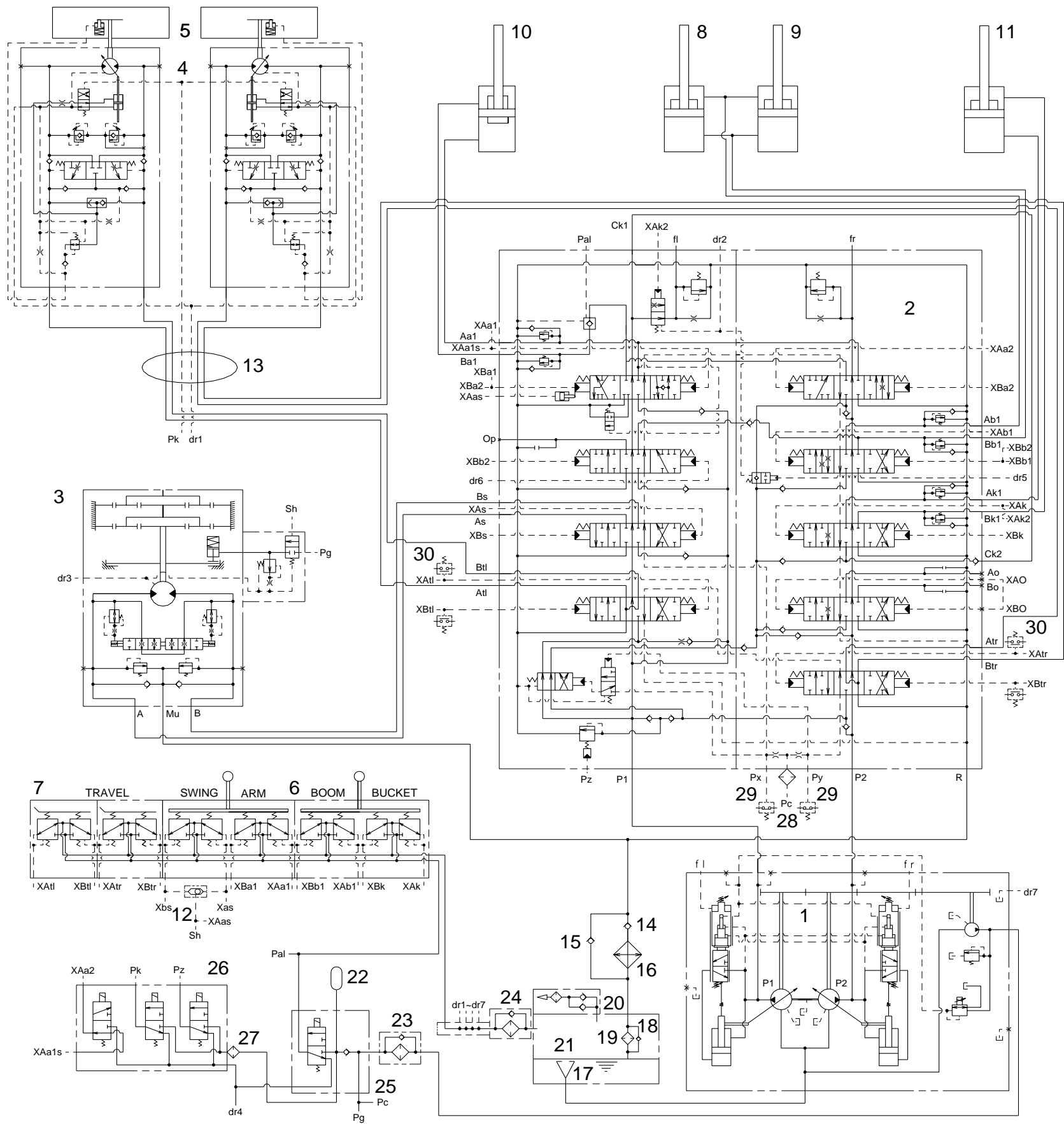

- 1 MAIN PUMP
- 2 MAIN CONTROL VALVE
- 3 SWING MOTOR
- 4 TRAVEL MOTOR
- 5 GEAR BOX
- 6 RCV LEVER
- 7 RCV LEVER
- 8 BOOM CYLINDER(RH)
- 9 BOOM CYLINDER(LH)
- 10 ARM CYLINDER
- 11 BUCKET CYLINDER
- 12 SHUTTLE VALVE
- 13 TURNING JOINT
- 14 CHECK VALVE
- 15 CHECK VALVE
- 16 OIL COOLER
- 17 STRAINER
- 18 RETURN FILTER
- 19 BYPASS VALVE
- 20 AIR BREATHER
- 21 HYDRAULIC TANK
- 22 ACCUMULATOR
- 23 LINE FILTER
- 24 SPIN FILTER
- 25 1 SOLENOID VALVE
- 26 2 SOLENOID VALVE
- 27 LAST GUARD FILTER
- 28 LAST GUARD FILTER
- 29 PRESSURE SWITCH
- 30 PRESSURE SWITCH