

GROUP 15 EPPR VALVE

1. EPPR VALVE

EPPR(Electro Proportional Pressure Reducing) valve consist of electro magnet and spool valve installed at main hydraulic pump.

1) ELECTRO MAGNET VALVE

Receive electric current from CPU controller and move the spool proportionally depend on the specific amount of electric current value.

2) SPOOL VALVE

Is the two way direction control valve for pilot pressure to reducing hydraulic pump flow. When electro magnet valve activate, pilot pressure enter to flow regulator at hydraulic pump. So, pump flow decrease to prevent engine stall.

3) PRESSURE AND ELECTRIC CURRENT VALUE FOR EACH MODE

Mode	Pressure		Electric current (mA)	Engine rpm
	kg/cm ²	psi		
H	–	–	200 ± 30	2250 + 50
S	9 ± 3	130 ± 40	420 ± 30	2250 + 50
L	9 ± 3	130 ± 40	420 ± 30	2000 + 50
F	13 ± 3	190 ± 40	510 ± 30	1650 + 50
★	9 ± 3	130 ± 40	420 ± 30	–

★ Manually operated condition when prolix switch is selected emergency position.

2. OPERATING PRINCIPLE

1) STRUCTURE

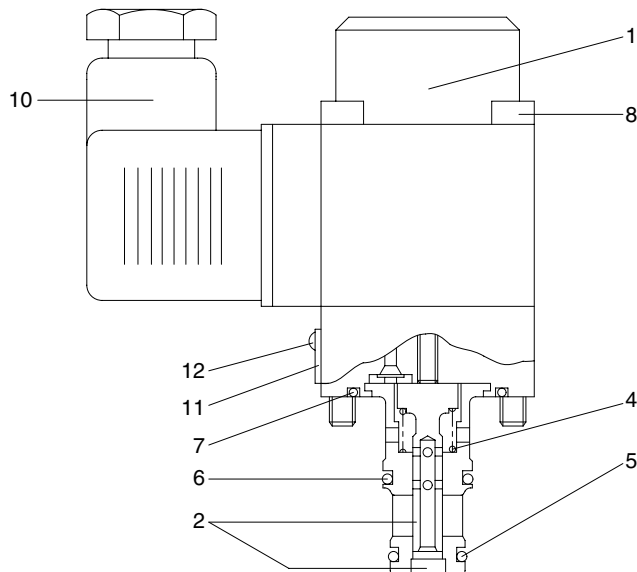

- 1 Solenoid without emergency switch
- 2 Cartridge
- 4 Compression spring
- 5 O-ring
- 6 O-ring
- 7 O-ring
- 8 Hexagon socket head bolt
- 10 Plug-in connector
- 11 Plate
- 12 Roundhead grooved pin

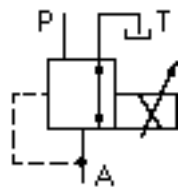

P Pilot oil supply line(Pilot pressure)

T Return to tank

A Secondary pressure to flow regulator at hydraulic pump.

2) AT H MODE

Pressure line blocked so, A oil return to tank.

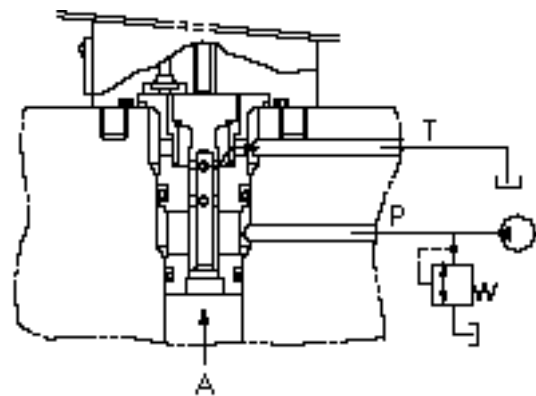
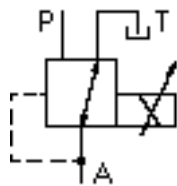

3) AT S, L, F MODE

Secondary pressure enter to A.

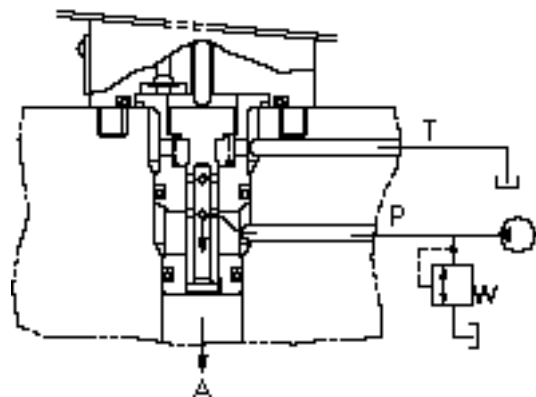
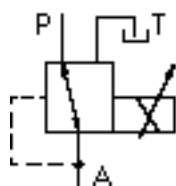

3. EPPR VALVE CHECK PROCEDURE

1) CHECK ELECTRIC VALUE AT EPPR VALVE

- (1) Start engine.
- (2) Set S-mode and cancel auto decel mode.
- (3) If tachometer show approx 2250+50rpm, disconnect one wire harness from EPPR valve.
- (4) Install multimeter as figure.
- (5) Check electric current at bucket circuit relief position.

Spec : 390~450mA

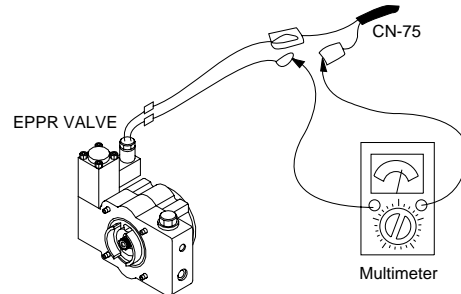

2) CHECK PRESSURE AT EPPR VALVE

- (1) Remove plug and connect pressure gauge as figure.
Gauge capacity : 0 to 40-50kg / cm²
(0 to 570-710psi)
- (2) Start engine.
- (3) Set S-mode and cancel auto decel mode.
- (4) If tachometer show approx 2250+50rpm, check pressure at relief position of bucket circuit by operating bucket control lever.
- (5) If pressure is not correct, adjust it.
- (6) After adjust, test the machine.

Spec : 6~12kg/cm²(85~170psi)

