

GROUP 14 ENGINE CONTROL SYSTEM

1. CPU CONTROLLER MOUNTING

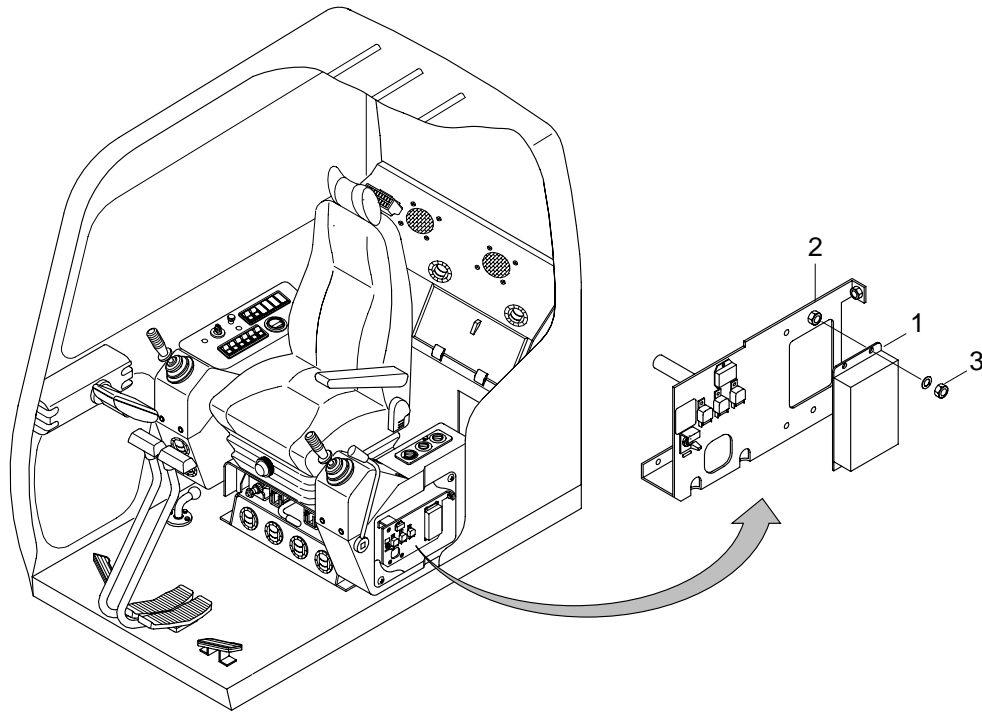

1 CPU controller 2 Controller mounting bracket 3 Nut

2. CPU CONTROLLER ASSEMBLY

- 1) Remove four pieces of nut(3) for controller mounting.
- 2) Disconnect 4 connectors from CPU controller.
- 3) Remove 4 pieces of screw and cover of CPU controller
- 4) Inspection : Check PCB(Printed Circuit Board)
 - (1) If any damage is found, replace CPU controller assembly.
 - (2) If not, but CAPO system does not work then replace **A** only.(A : EPROM)
 - ※ Removal : Insert small screwdriver or knife to bottom of EPROM and lift up carefully.
 - ※ Assembly : Assemble EPROM to mach with semicircle mark.

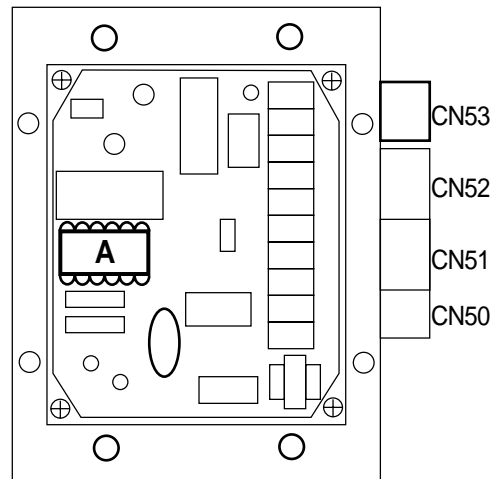

3. ENGINE GOVERNOR MOTOR AND EMERGENCY CABLE MOUNTING

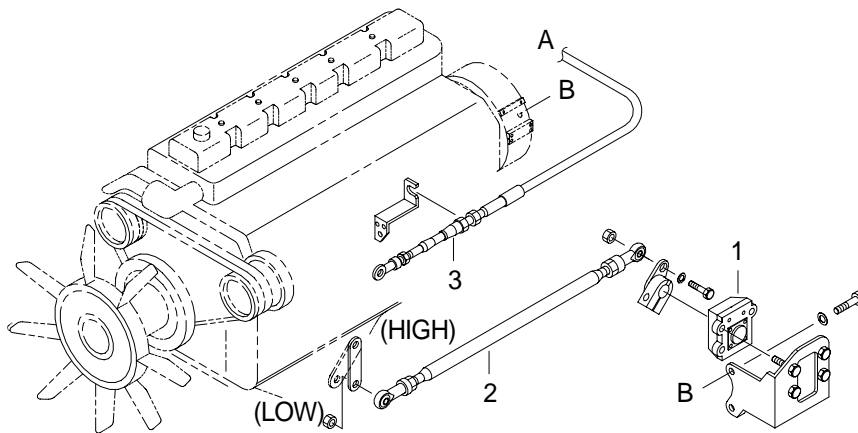
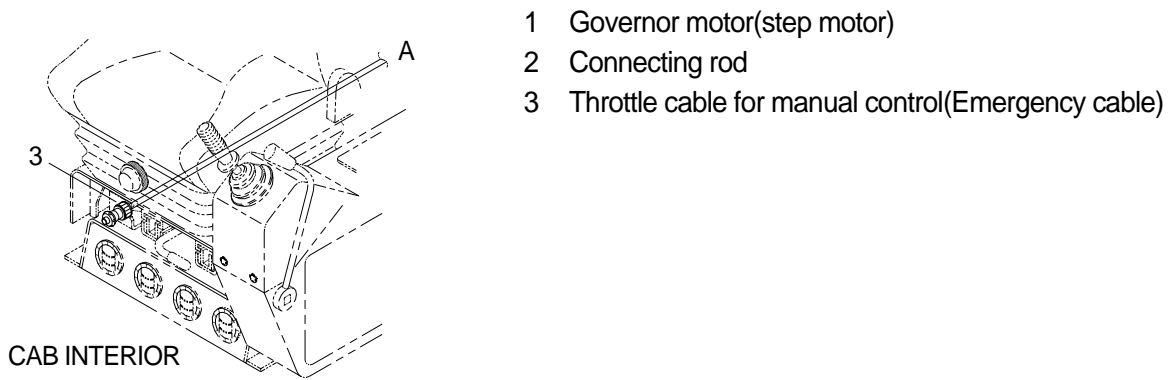

1) ENGINE THROTTLE LEVER

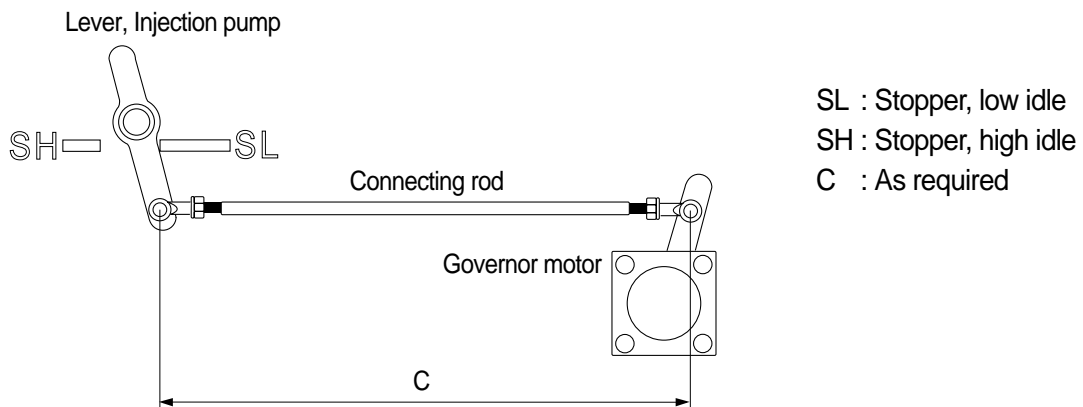

2) EMERGENCY CABLE (push-pull cable)

It controls engine speed by connecting onto the lever of the injection pump when the malfunction of the CPU controller or the governor motor happen.

3) ENGINE GOVERNOR MOTOR

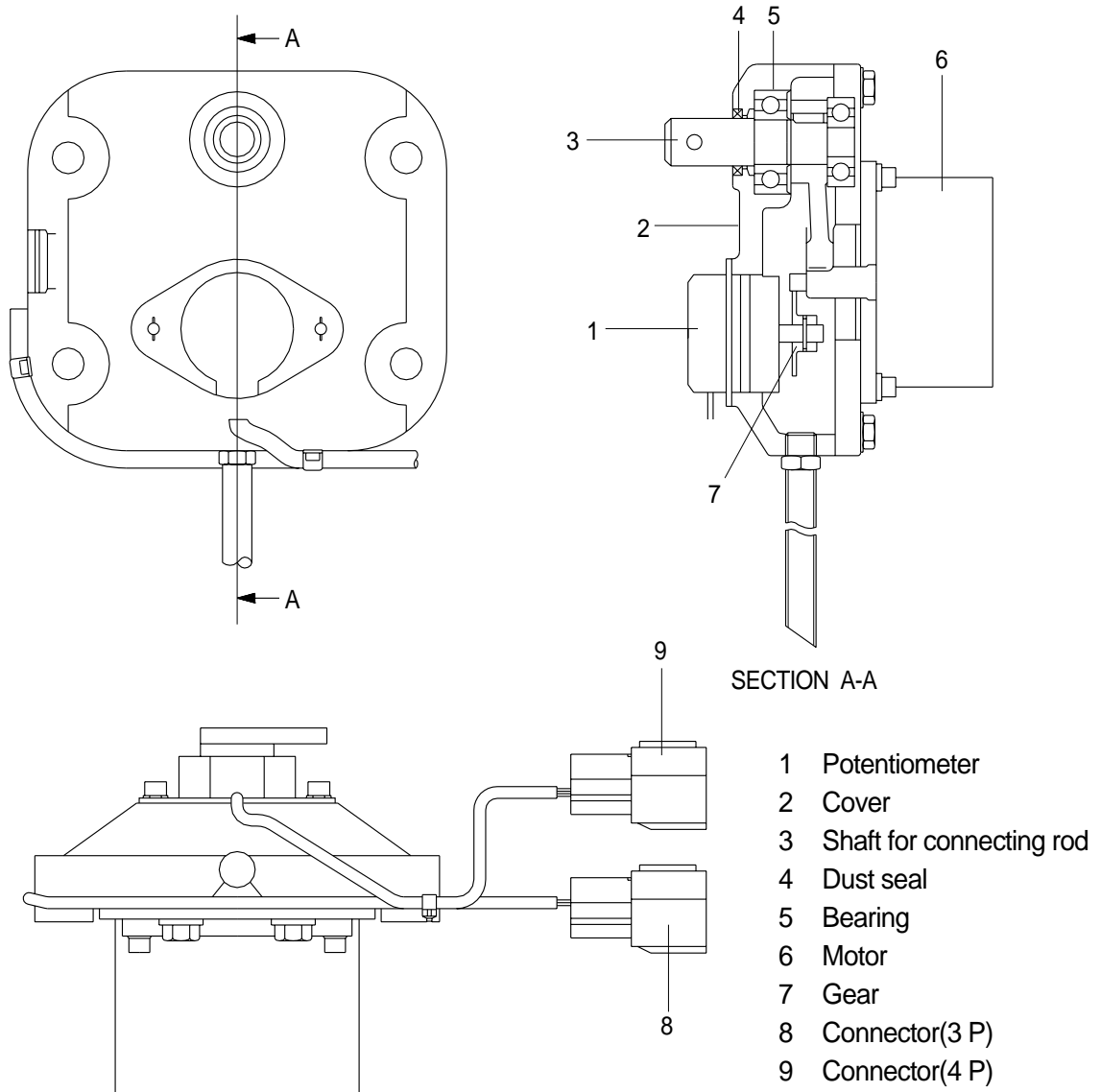

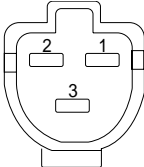
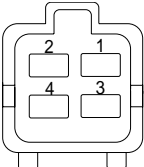
Connector		Potentiometer	Governor motor
			
Type		3P, female	4P, female
Line Color	1	Black line on blue	Yellow
	2	White line on blue	Blue line on yellow
	3	Blue line on green	White line on yellow
	4	—	Black line on yellow
Inspection of governor motor		<ul style="list-style-type: none"> · Check resistance between No. 1-2 · Spec : 0.6 ~ 6kΩ 	<ul style="list-style-type: none"> · Check resistance between No. 1-2 and 3-4. · Spec : 4 ~ 9Ω

4. ENGINE SPEED SENSOR

1) DETECT ACTUAL ENGINE RPM AND SEND SIGNAL TO TACHOMETER

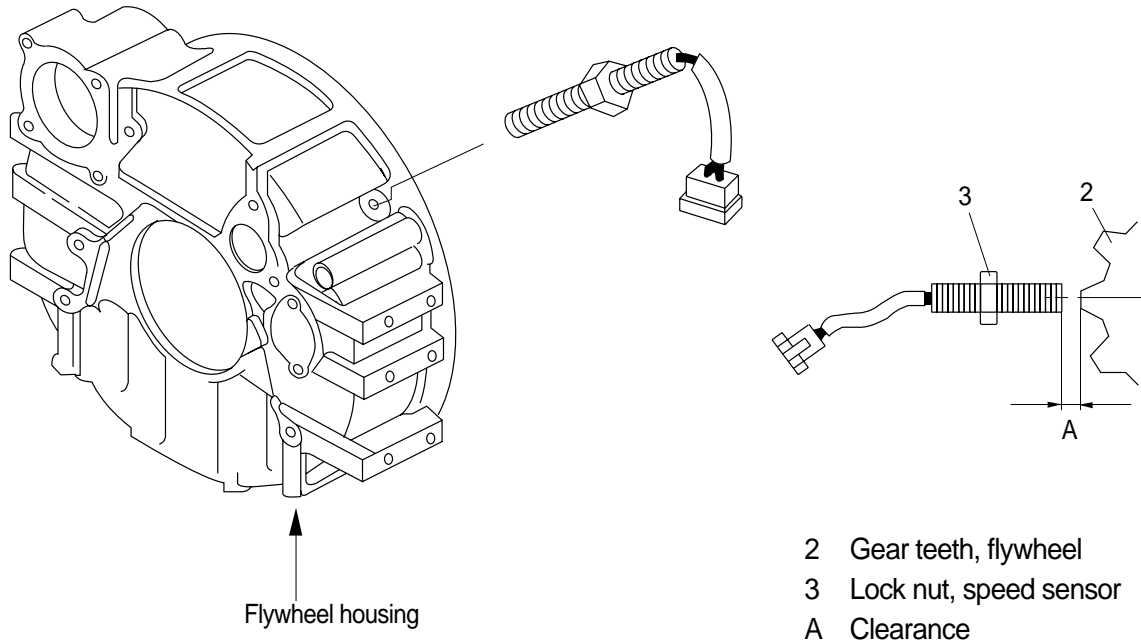

2) INSTALLATION

- (1) Clean contacting point of sensor.
- (2) Loosen lock nut.
- (3) Screw in speed sensor to flywheel housing.
- (4) Turn it back 135° when it contact gear teeth.
- (5) Tight lock nut and connect wiring.