

GROUP 5 ELECTRICAL SYSTEM BY HYPER DAT

1. WHEN STARTING SWITCH IS TURNED ON, MONITOR PANEL DISPLAY DOES NOT APPEAR

- Before using the HYPER DAT make sure you understand the user's guide of HYPER DAT.
- Before mounting or dismounting the HYPER DAT, always turn the starting switch OFF.
- Before starting switch turn ON or OFF, check all related connectors are properly inserted.

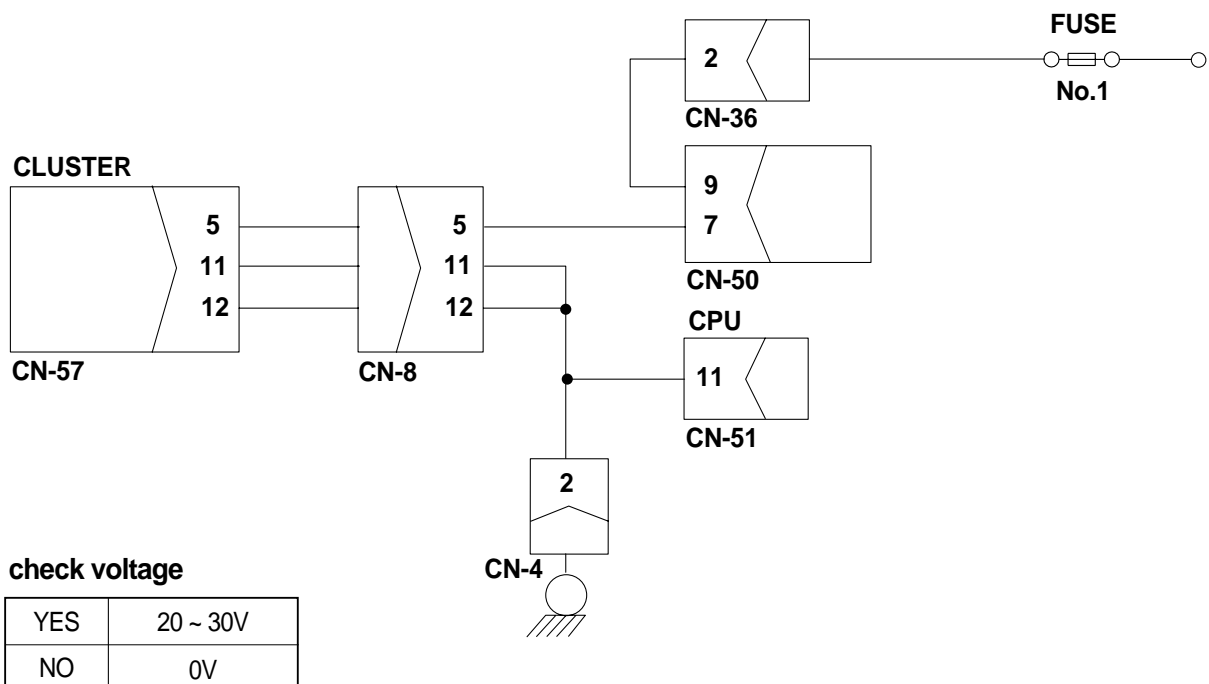
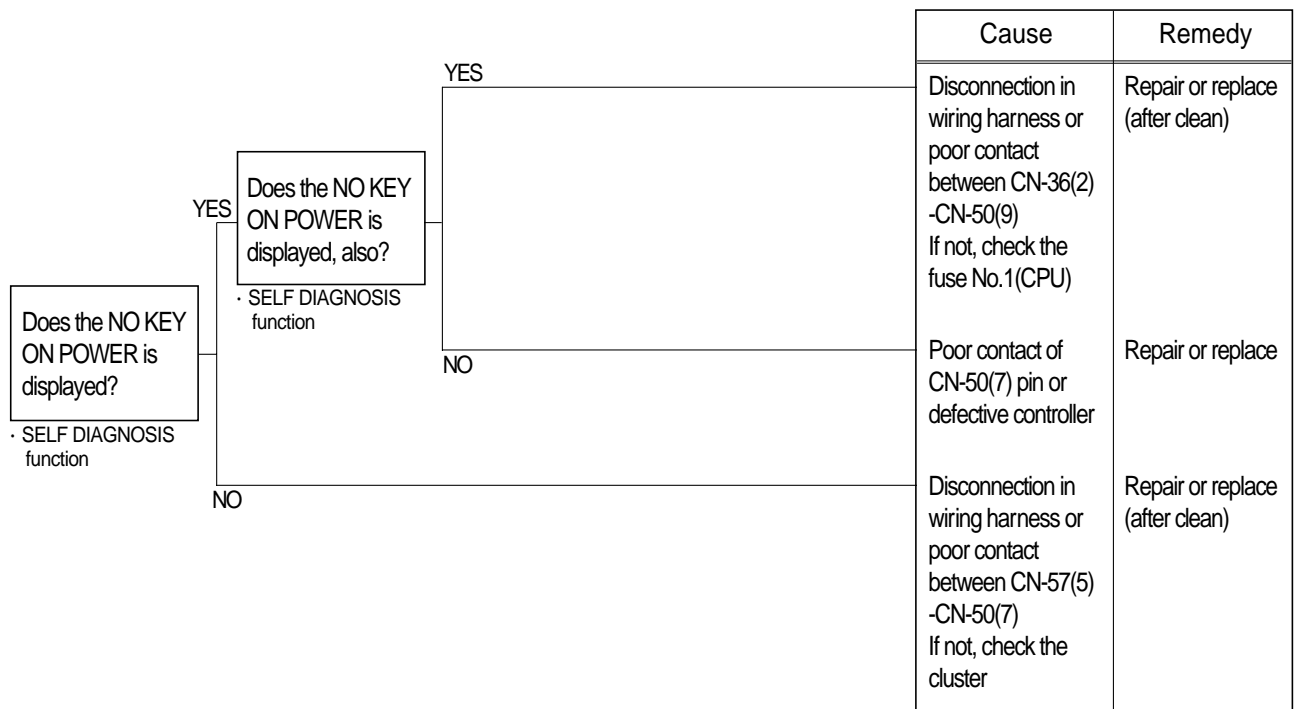

2. BATTERY CHARGING LAMP LIGHTS UP(Engine is started)

- Before using the HYPER DAT make sure you understand the user's guide of HYPER DAT.
- Before mounting or dismounting the HYPER DAT, always turn the starting switch OFF.
- Before starting switch turn ON or OFF, check all related connectors are properly inserted.

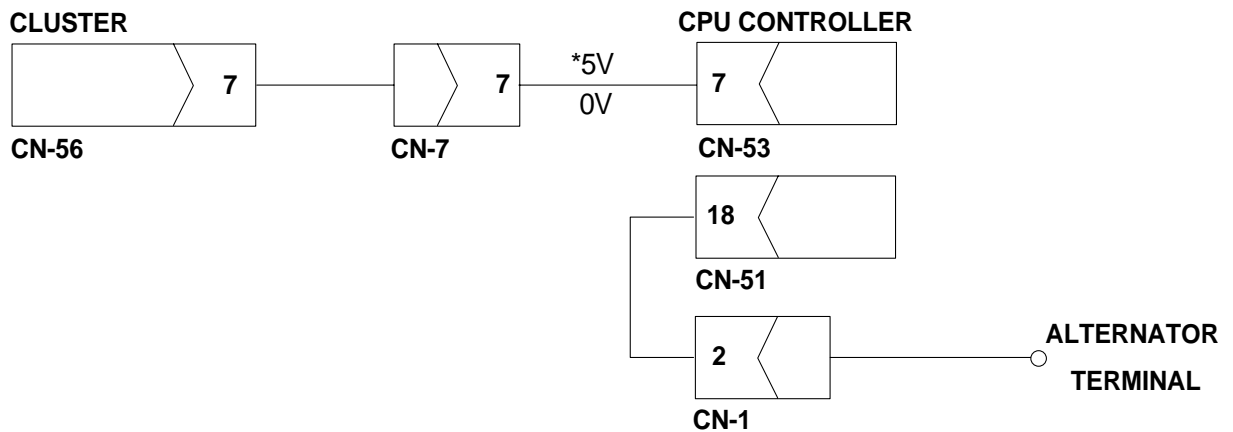
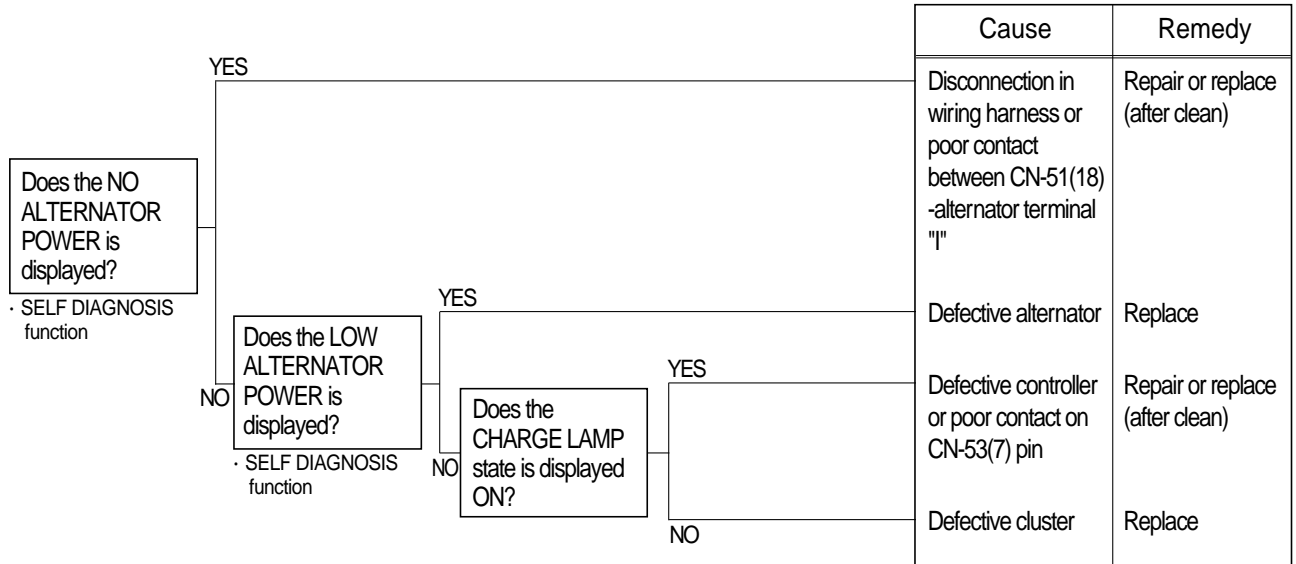

check voltage

YES	26 ~ 30V	*5V
NO	Below 26V	0V

3. WHEN COOLANT OVERHEAT LAMP LIGHTS UP(Engine is started)

- Before using the HYPER DAT make sure you understand the user's guide of HYPER DAT.
- Before mounting or dismounting the HYPER DAT, always turn the starting switch OFF.
- Before starting switch turn ON or OFF, check all related connectors are properly inserted.

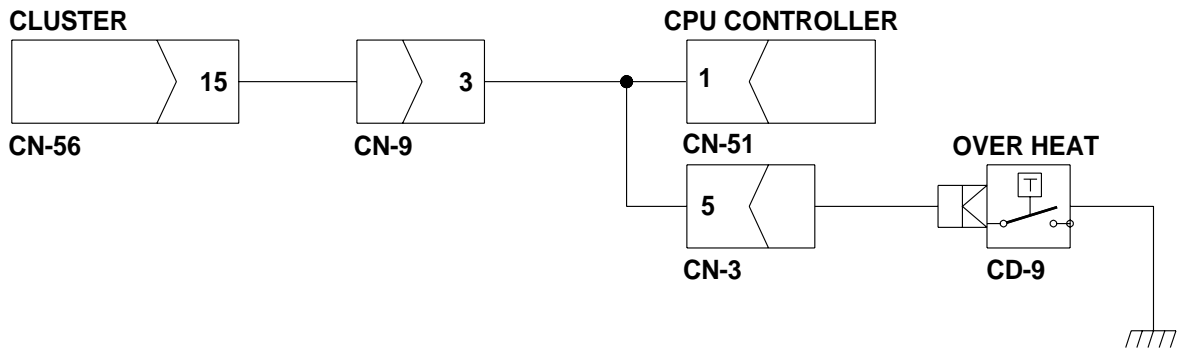

check resistance

YES	MAX 1Ω
NO	MIN 1 MΩ

4. WHEN HYDRAULIC OIL TEMPERATURE LAMP LIGHTS UP(Engine is started)

- Before using the HYPER DAT make sure you understand the user's guide of HYPER DAT.
- Before mounting or dismounting the HYPER DAT, always turn the starting switch OFF.
- Before starting switch turn ON or OFF, check all related connectors are properly inserted.

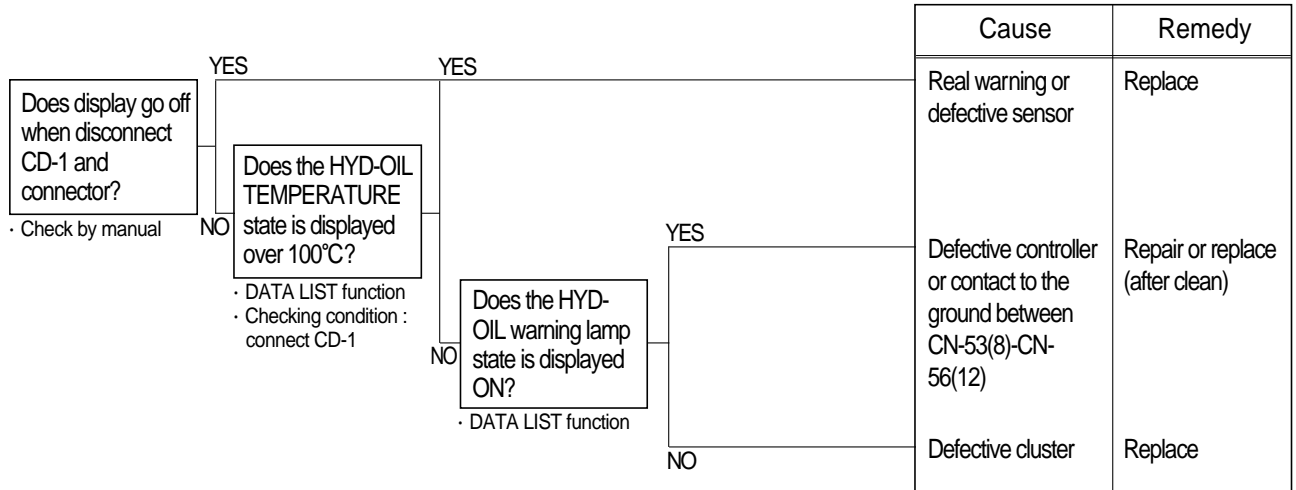

check resistance

YES	MAX 1Ω
NO	MIN 1 MΩ

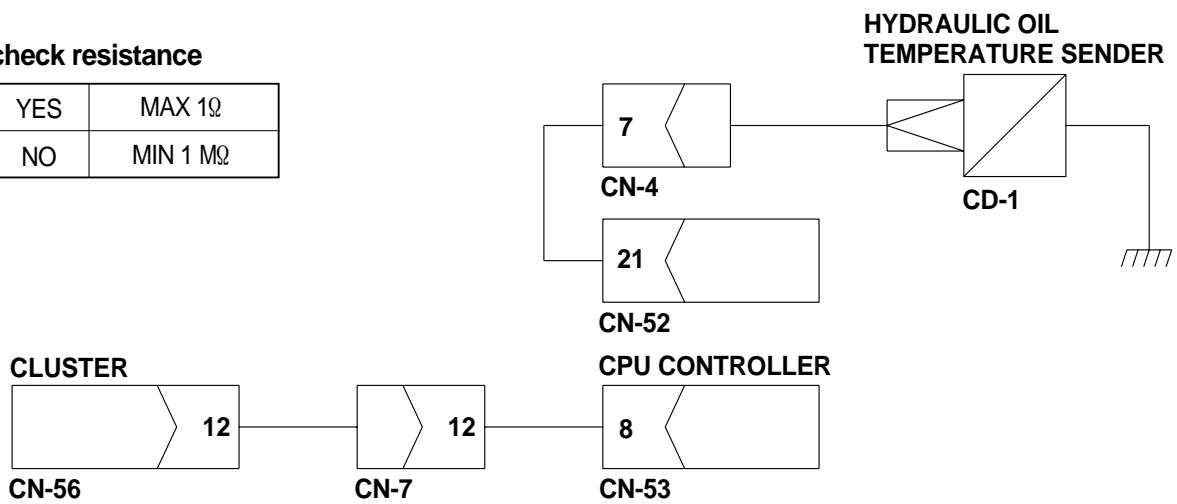

5. WHEN TRAVEL SPEED 1, 2 DOES NOT OPERATE

- Before using the HYPER DAT make sure you understand the user's guide of HYPER DAT.
- Before mounting or dismounting the HYPER DAT, always turn the starting switch OFF.
- Before starting switch turn ON or OFF, check all related connectors are properly inserted.

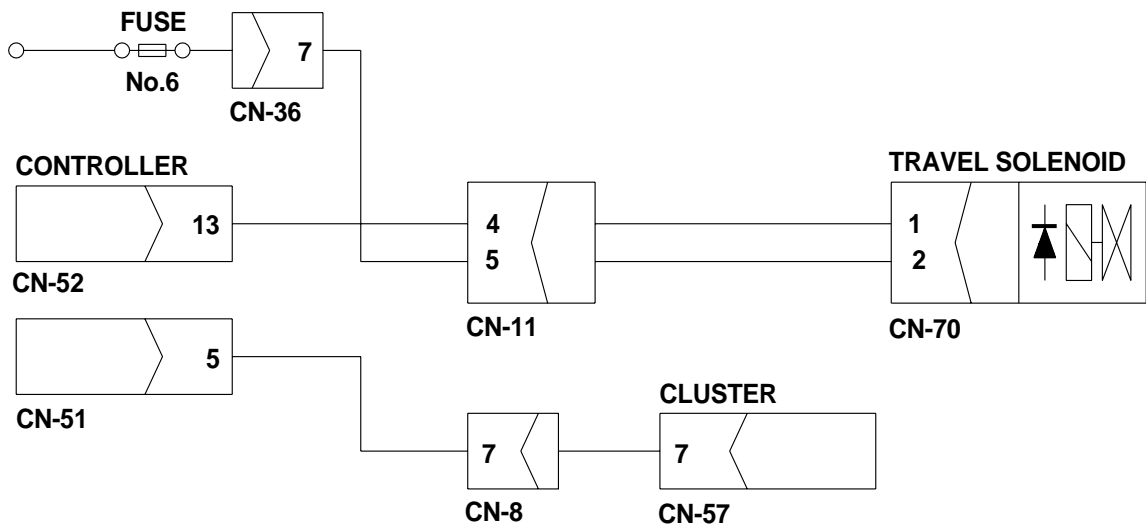
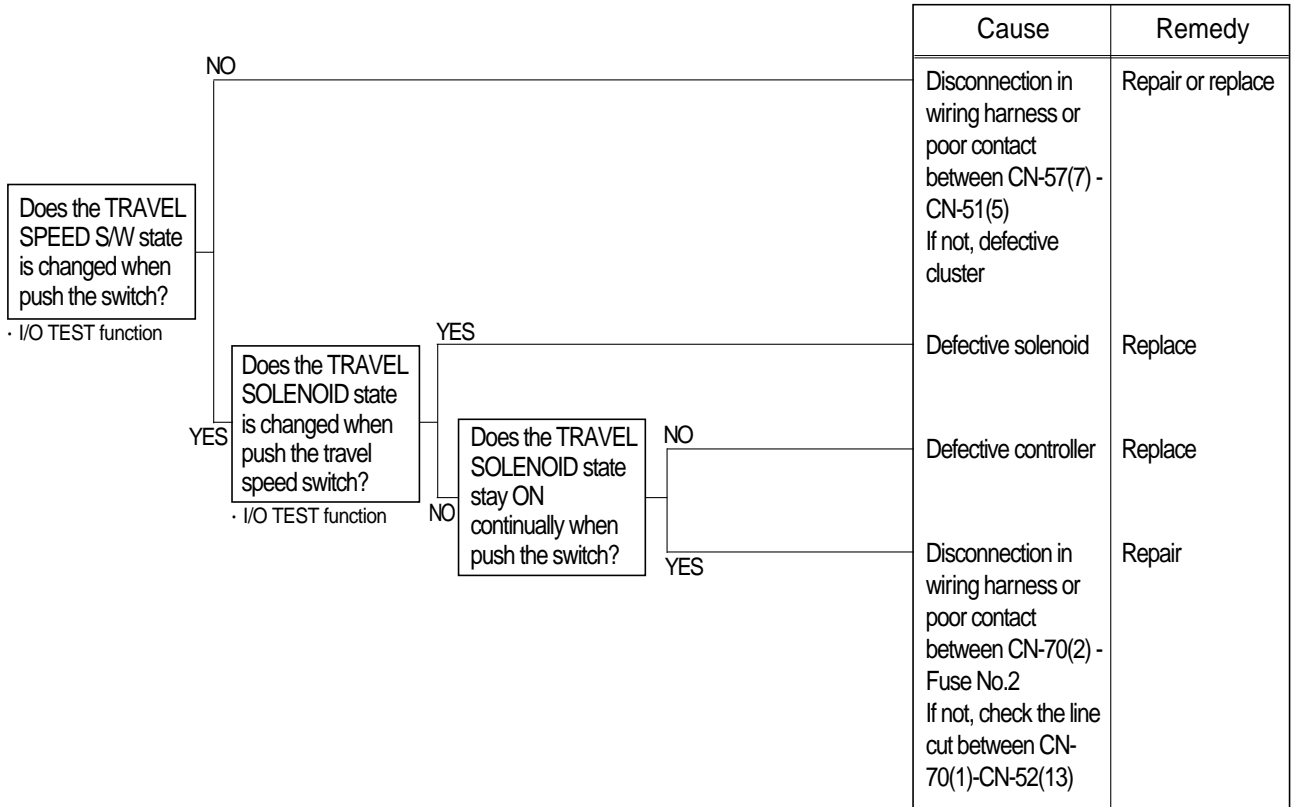

6. ENGINE DOES NOT STOP, WHEN TURN THE START KEY OFF

- Before using the HYPER DAT make sure you understand the user's guide of HYPER DAT.
- Before mounting or dismounting the HYPER DAT, always turn the starting switch OFF.
- Before starting switch turn ON or OFF, check all related connectors are properly inserted.

