

GROUP 2 ELECTRICAL CIRCUIT(up to #138)

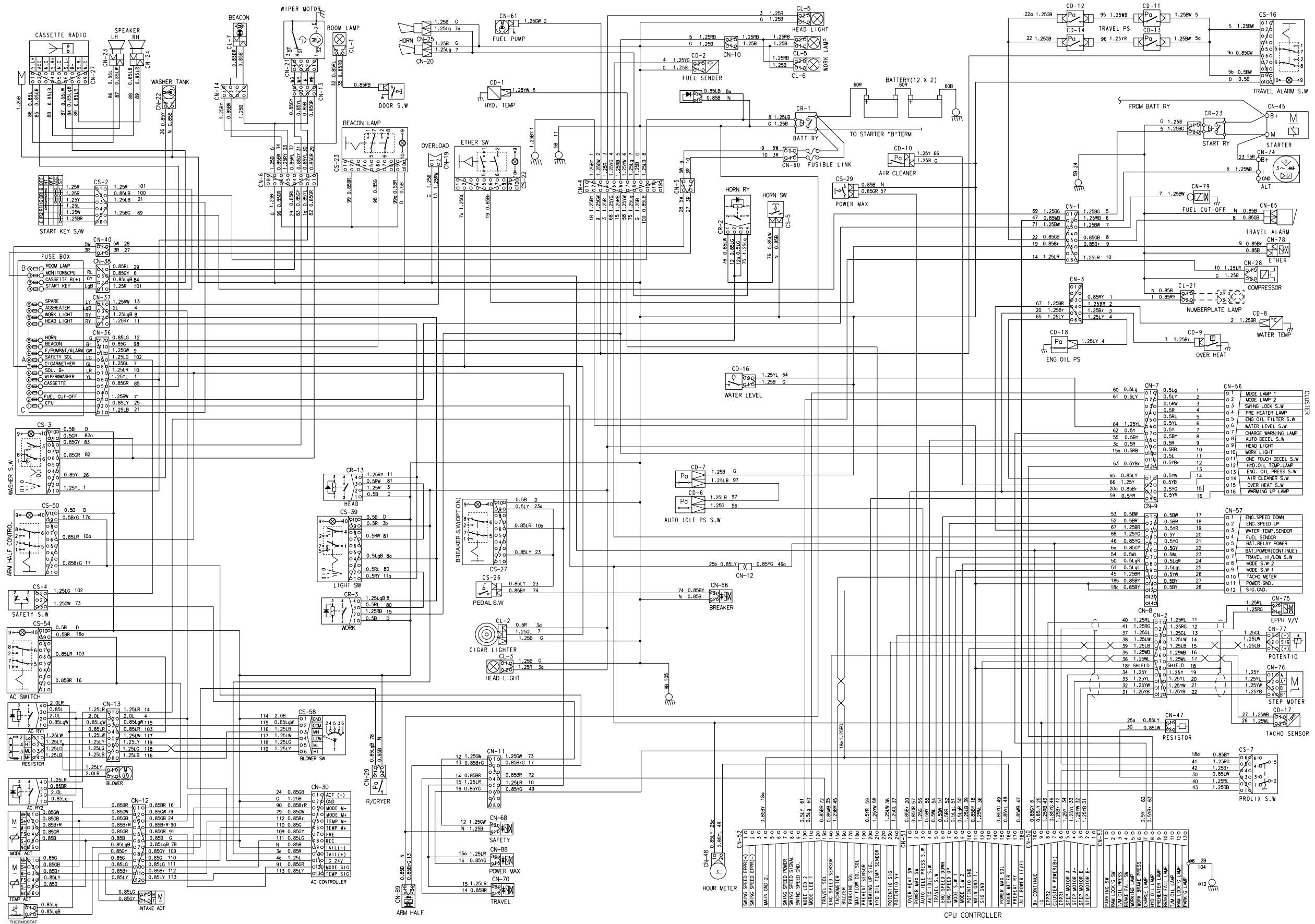

ELECTRICAL CIRCUIT(#642~#965)

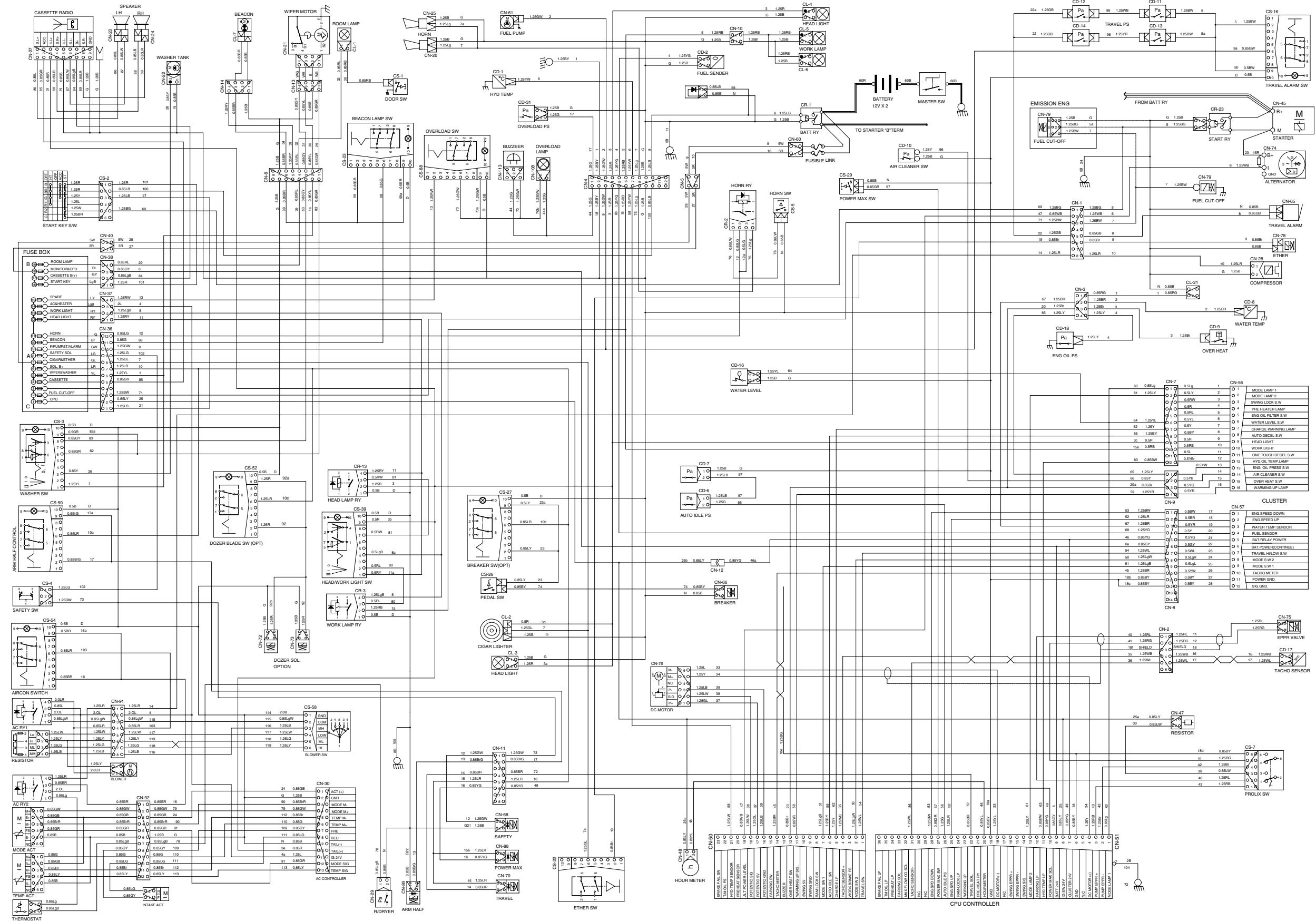

ELECTRICAL CIRCUIT(#966 and up)

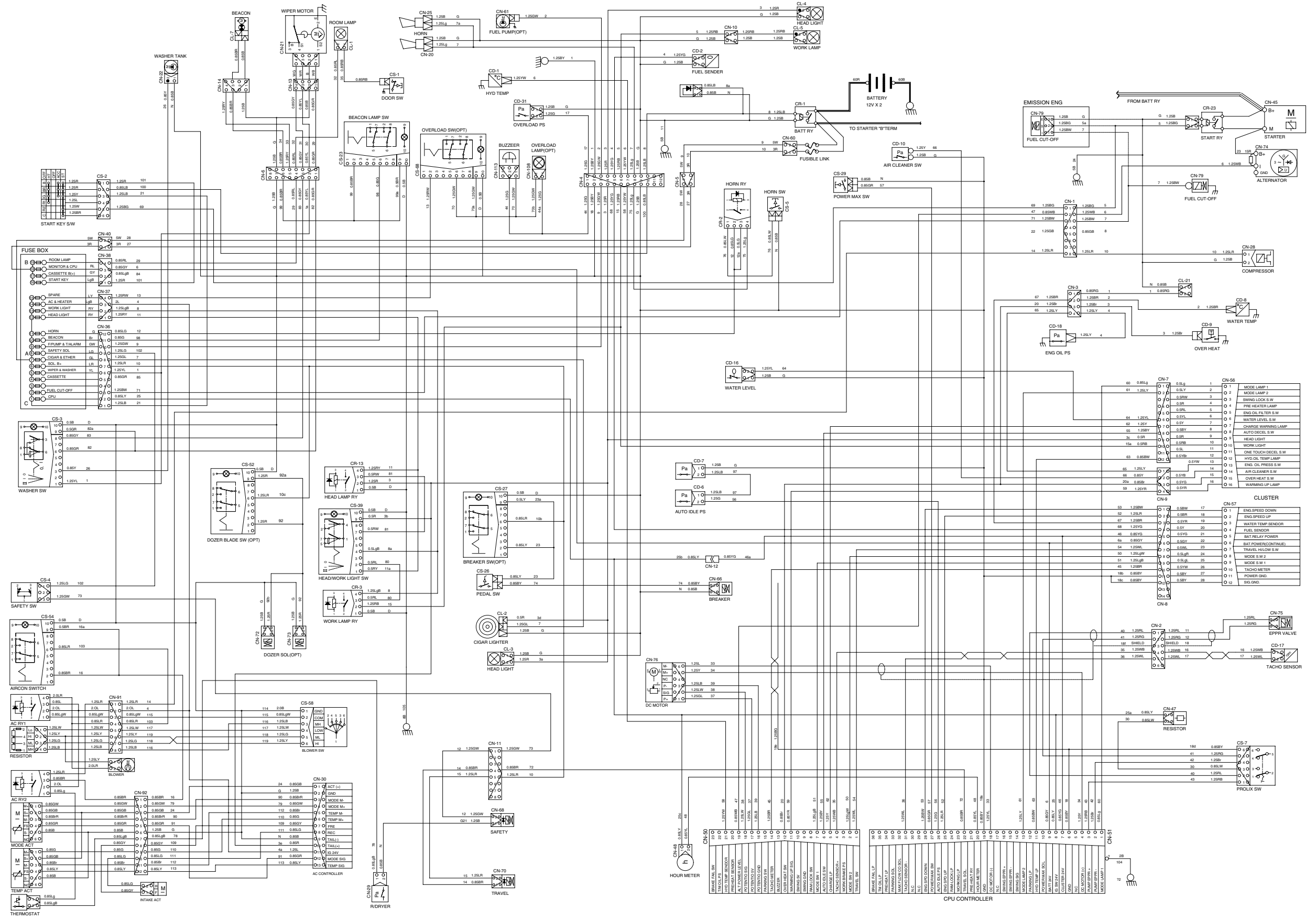

1. POWER CIRCUIT

The negative terminal of battery is grounded to the machine chassis.

When the start switch is in the OFF position, the current flows from the positive battery terminal as shown below.

1) OPERATING FLOW

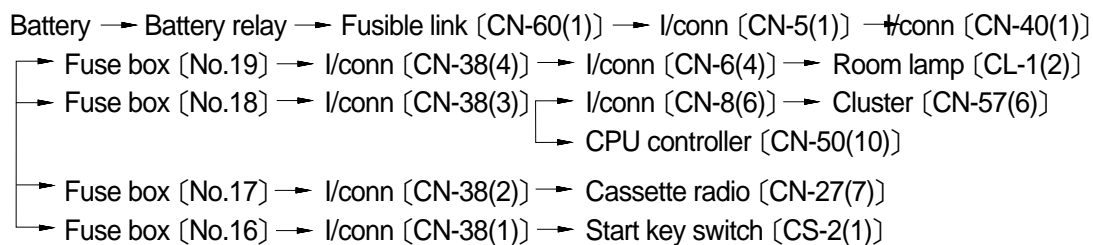

※ I/conn : Intermediate connector

2) CHECK POINT

Engine	Start switch	Check point	Voltage
OFF	OFF	① - GND (Battery 1 EA)	10 ~ 12.5V
		② - GND (Battery 2 EA)	20 ~ 25V
		③ - GND (Battery 2 EA)	20 ~ 25V
		④ - GND (Fusible link)	20 ~ 25V

※ GND : Ground

POWER CIRCUIT

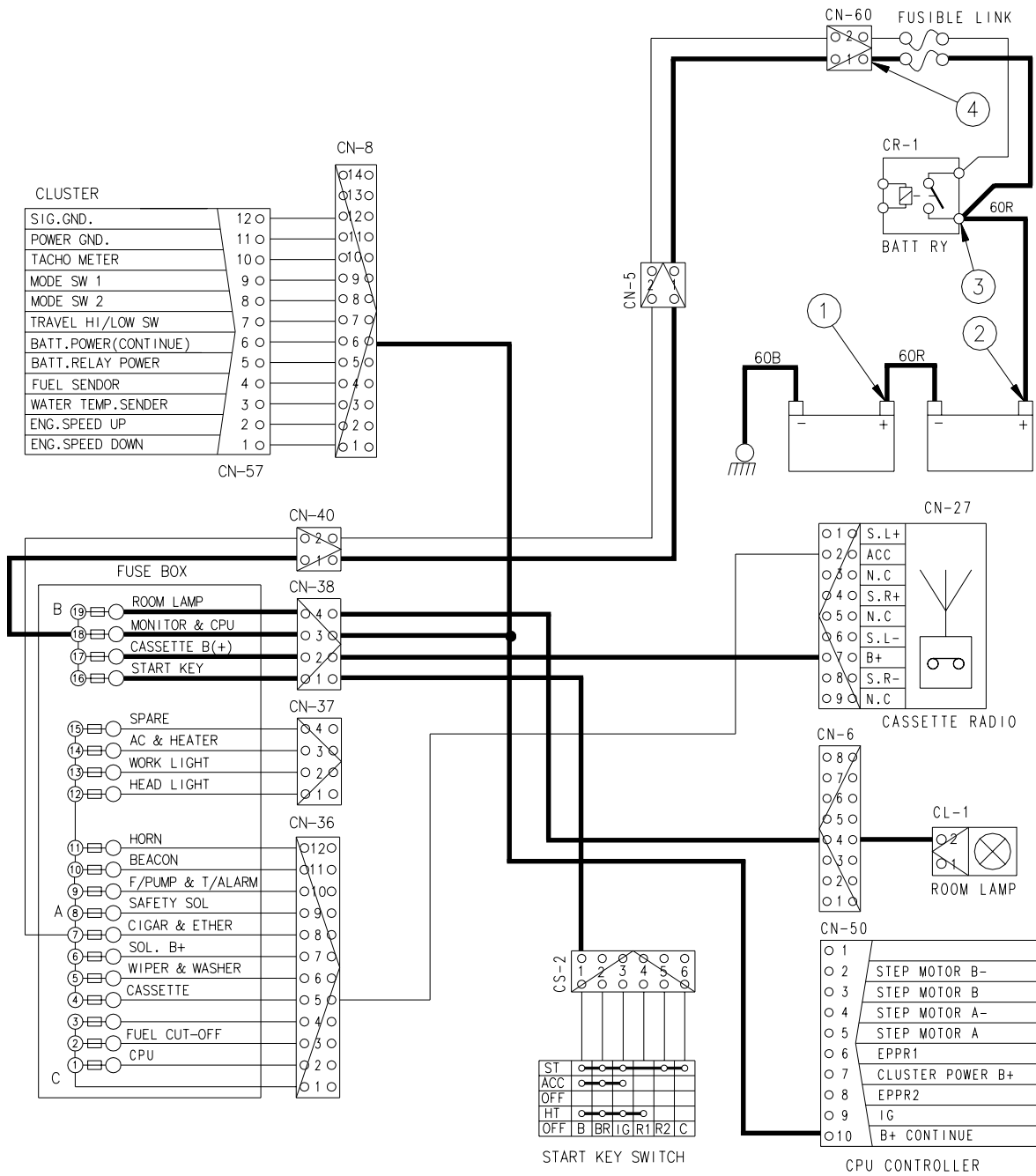

2. STARTING CIRCUIT

1) OPERATING FLOW

Battery(+) terminal → Battery relay(M8, B⁺ terminal) → Fusible link (CN-60(1))
 → I/conn (CN-5(1)) → I/conn (CN-40(1)) → Fuse box (No.16) → I/conn (CN-38(1))
 → Start switch (CS-2(1))

(1) When start key switch is in ON position

Start switch ON (CS-2(2)) → I/conn (CN-4(10)) → Battery relay (M4 terminal)
 → Battery relay operating(All power is supplied with the electric component)
 Start switch ON (CS-2(3)) → I/conn (CN-36(1))
 → Fuse box (No.1)
 → Fuse box (No.3)
 → Fuse box (No.2) → I/conn (CN-36(3)) → I/conn (CN-1(3))
 → Fuel cut-off (CN-79)

(2) When start key switch is in START position

Start switch START (CS-2(5)) → I/conn (CN-1(1)) → Start relay (CR-23(2))

2) CHECK POINT

Engine	Start switch	Check point	Voltage
Operating	Start	① - GND (Battery) ② - GND (Start key) ③ - GND (Battery relay M4) ④ - GND (Start B+) ⑤ - GND (Start M) ⑥ - GND (Start relay) ⑦ - GND (Battery relay M8)	20 ~ 25V

※ GND : Ground

STARTING CIRCUIT

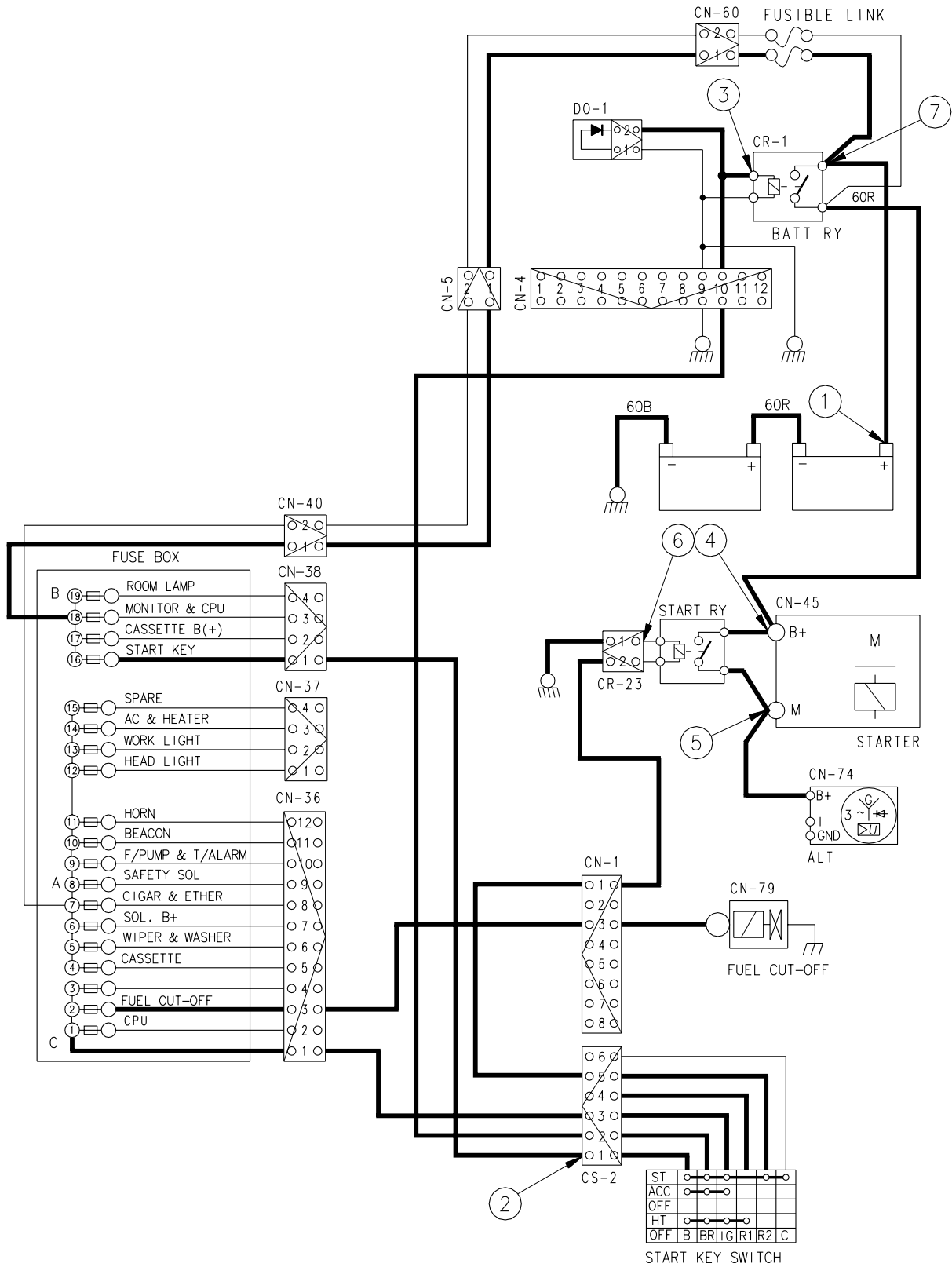

CHARGING CIRCUIT

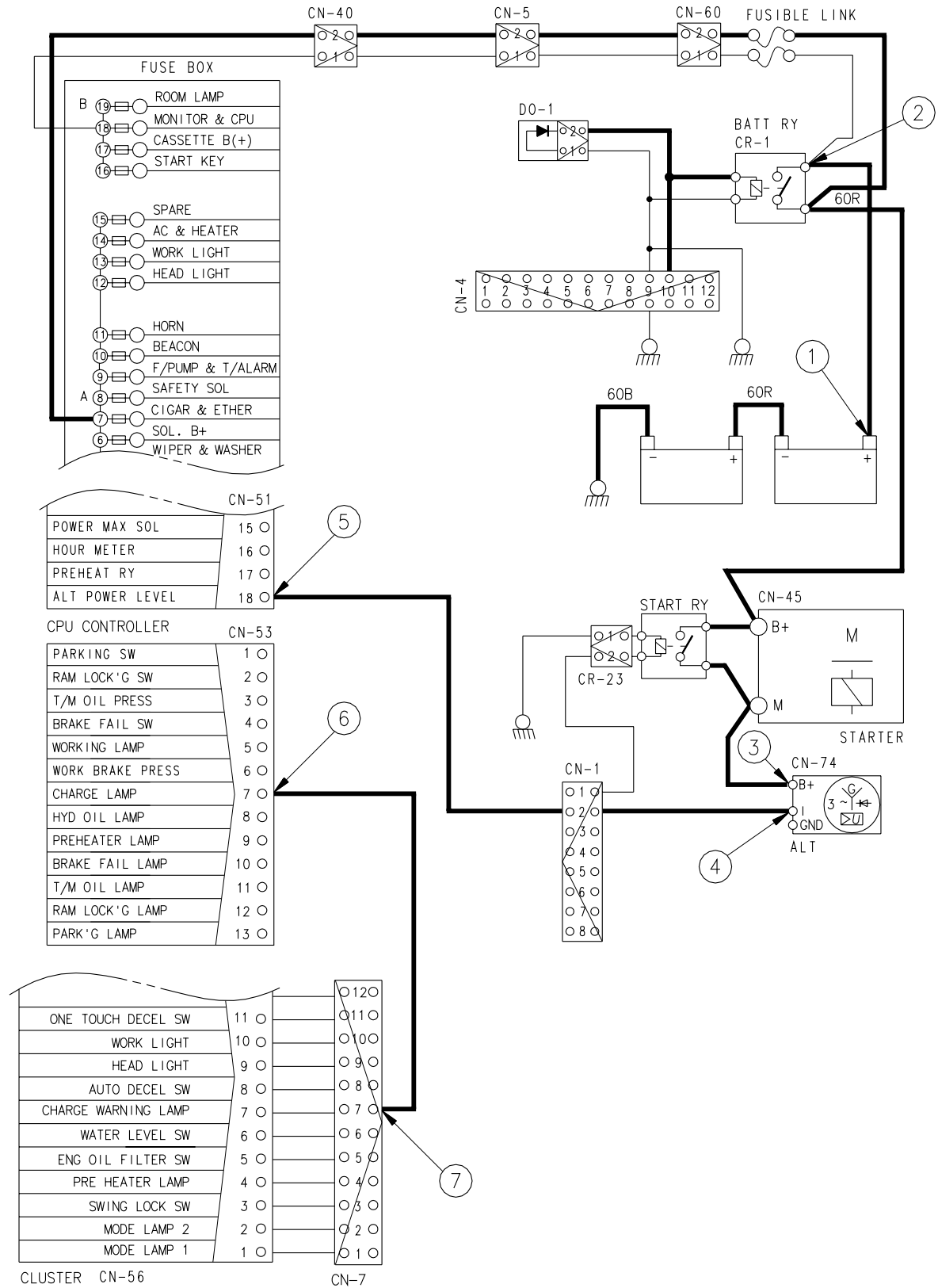

4. HEAD AND WORK LIGHT CIRCUIT

1) OPERATING FLOW

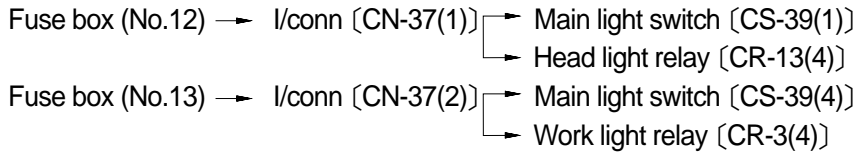

(1) Head light switch ON : 1st step

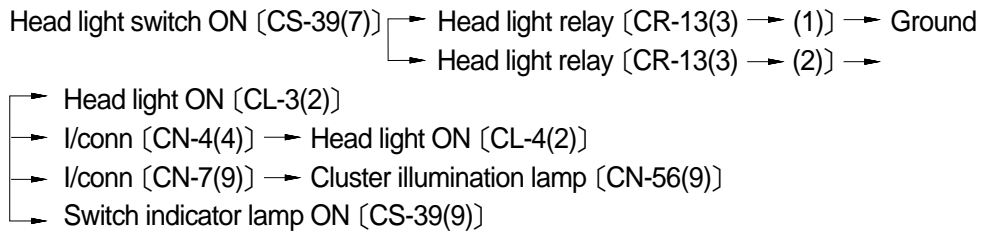

(2) Work Light switch ON : 2nd step

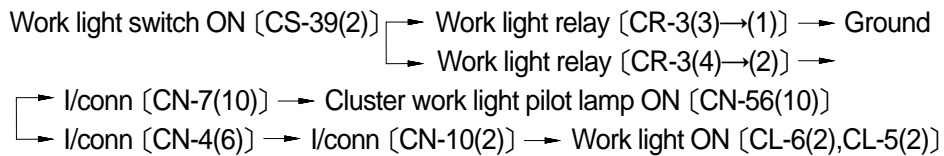

2) CHECK POINT

Engine	Key switch	Check point	Voltage
STOP	ON	① - GND(Fuse box) ③ - GND(Switch power input) ⑤ - GND(Switch power output) ⑦ - GND(Relay input) ⑨ - GND(Relay coil) ⑪ - GND(Relay output) ⑬ - GND(Work lamp)	20 ~ 25V
STOP	ON	② - GND(Fuse box) ④ - GND(Switch power input) ⑥ - GND(Switch power output) ⑧ - GND(Relay input) ⑩ - GND(Relay coil) ⑫ - GND(Relay output) ⑭ - GND(Head lamp)	20 ~ 25V

※ GND : Ground

HEAD AND WORK LAMP CIRCUIT

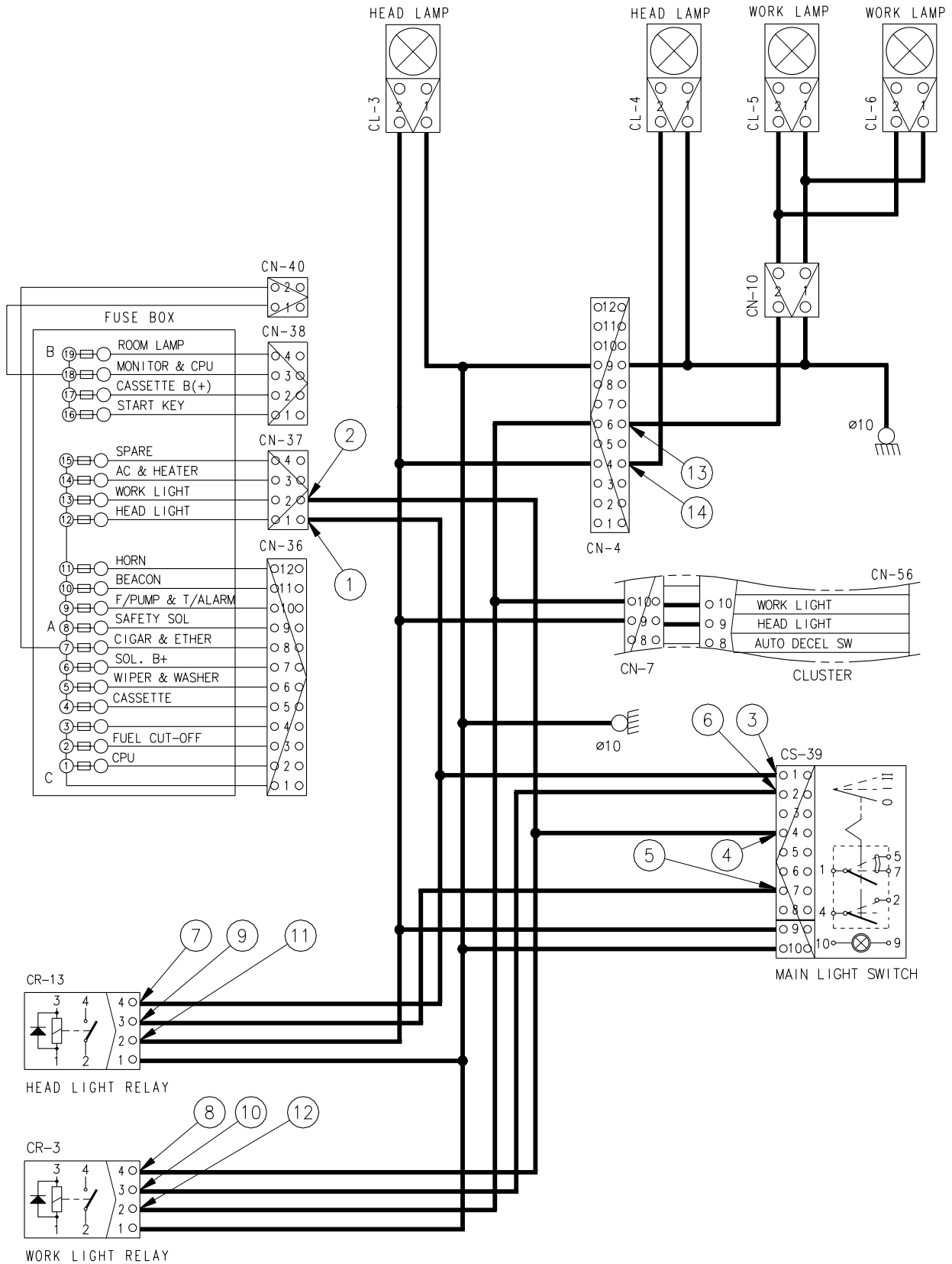

5. BEACON LAMP CIRCUIT

1) OPERATING FLOW

Fuse box (No.10) → I/conn [CN-36(11)] → Beacon lamp switch [CS-23(6)]

※ When lamp switch ON

Beacon lamp switch ON [CN-23(2)] → I/conn [CN-6(6)] → I/conn [CN-14(3)] →
Beacon lamp ON [CL-7]

2) CHECK POINT

Engine	Key switch	Check point	Voltage
STOP	ON	① - GND (Fuse box) ② - GND (Switch power input) ③ - GND (Switch power output) ④ - GND (Beacon lamp)	20 ~ 25V

※ GND : Ground

BEACON LAMP CIRCUIT

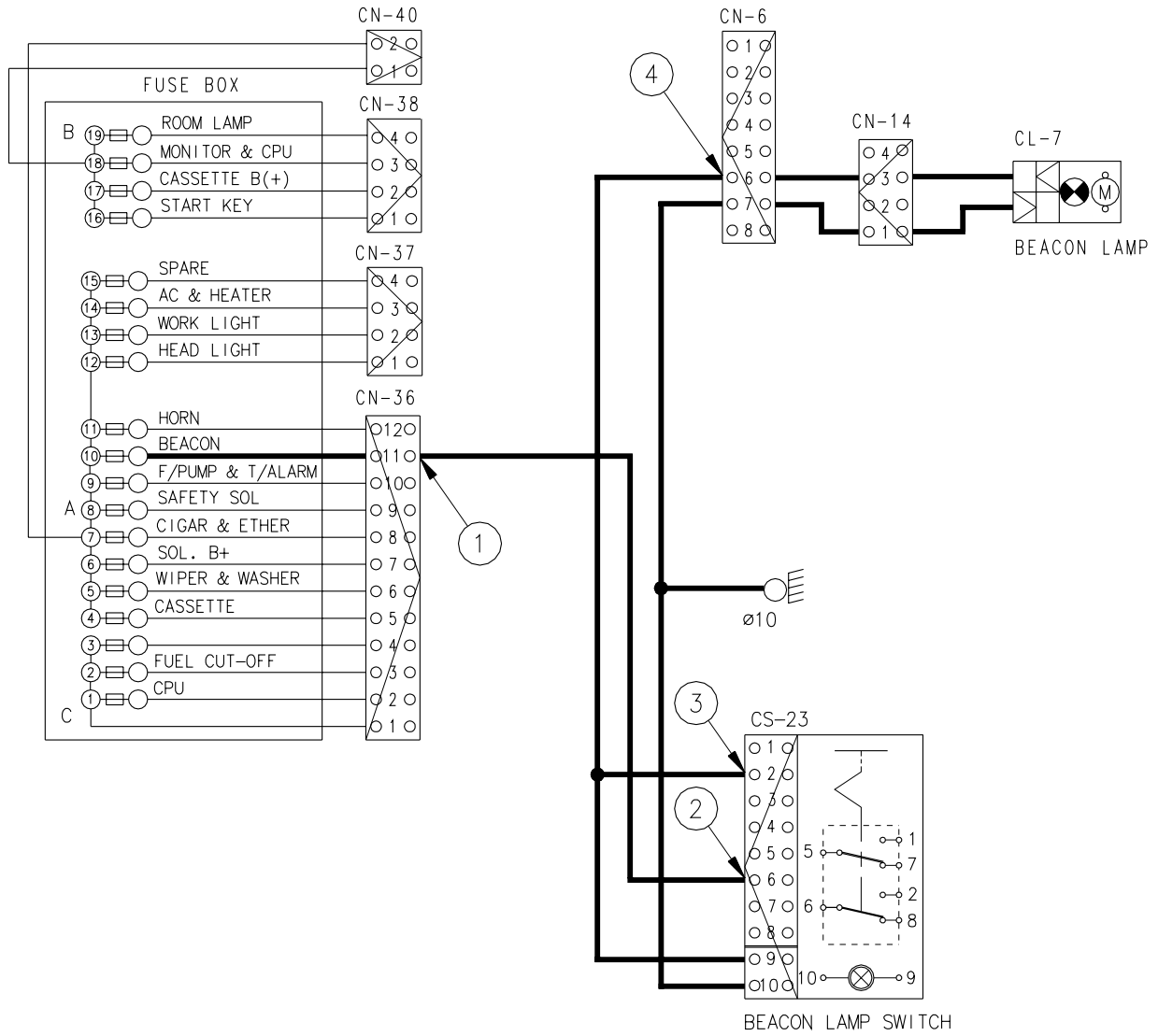

6. WIPER AND WASHER CIRCUIT

1) OPERATING FLOW

(1) Wiper motor switch ON : 1st step

Fuse box (No.5) → I/conn [CN-36(6)] → Wiper and washer switch [CS-3(1) → (6)] →
I/conn [CN-6(2)] → I/conn [CN-13(1)] → Wiper operation [CS-21(1)]

(2) Washer switch ON : 2nd step

Fuse box(No.5) → I/conn [CN-36(6)] → Wiper and washer switch [CS-3(1) → (3)] →
Washer tank [CN-22(2) → (1)] → Washer operation
I/conn [CN-6(1)] → I/conn [CN-13(1)] →
Wiper motor operation [CN-21(1)]

(3) Auto-parking (when switch OFF)

Wiper & washer switch OFF [CS-3(6) → (8)] → Wiper motor [CN-21(1)] →
Fuse box(No.5) → I/conn [CN-36(6)] → I/conn [CN-6(2)] → I/conn [CN-13(3)] →
Wiper and washer switch [CN-21(3)→(4)] → Wiper motor stop

2) CHECK POINT

Engine	Start switch	Check point	Voltage
STOP	ON	① - GND (Fuse box) ② - GND (Switch power input) ③ - GND (Switch power output) ④ - GND (Wiper power input) ⑤ - GND (Wiper power input) ⑥ - GND (Wiper motor) ⑦ - GND (Switch power output)	20 ~ 25V

※ GND : Ground

WIPER AND WASHER CIRCUIT

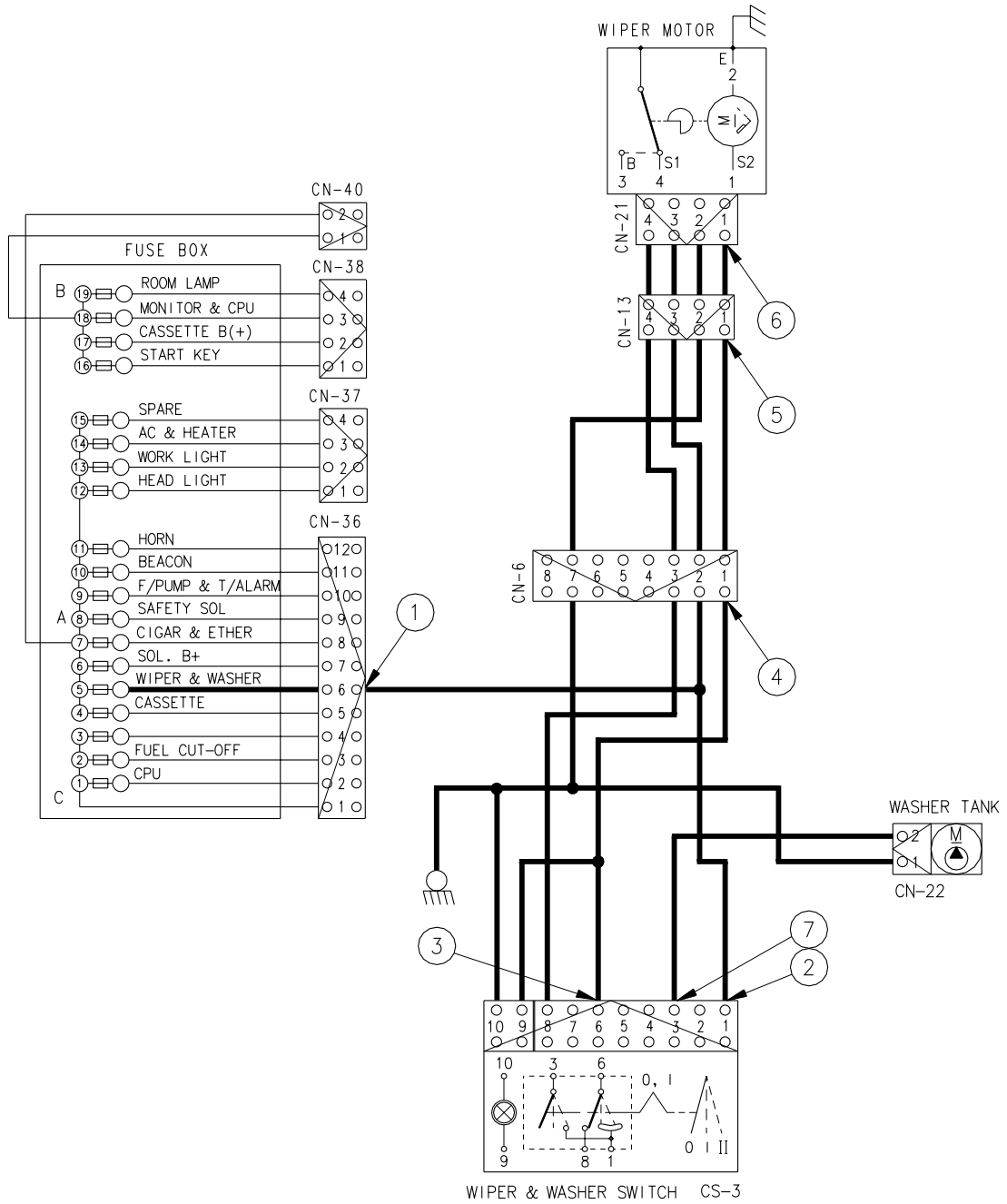

CONTROLLER CIRCUIT

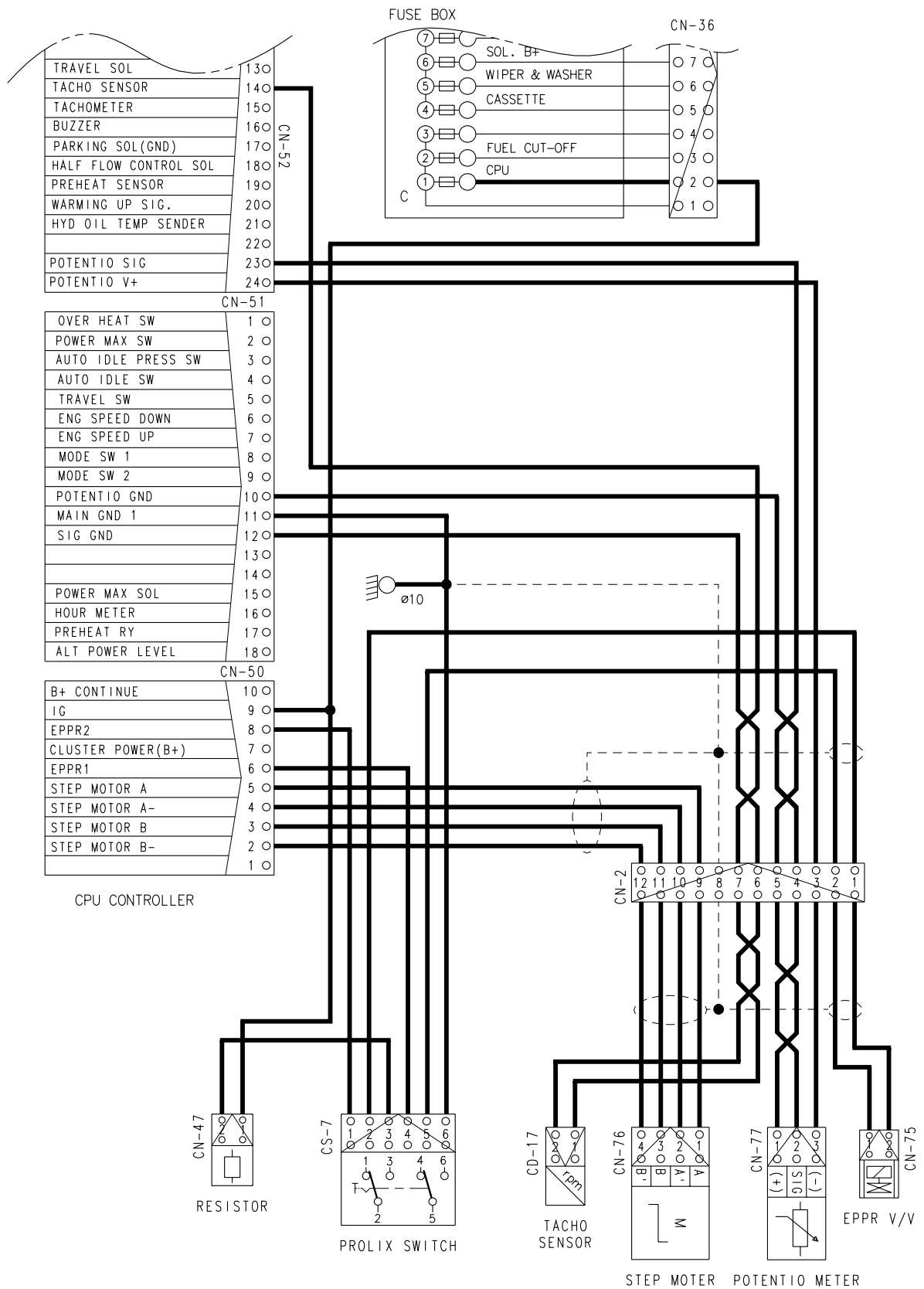

ELECTRIC CIRCUIT FOR HYDRAULIC

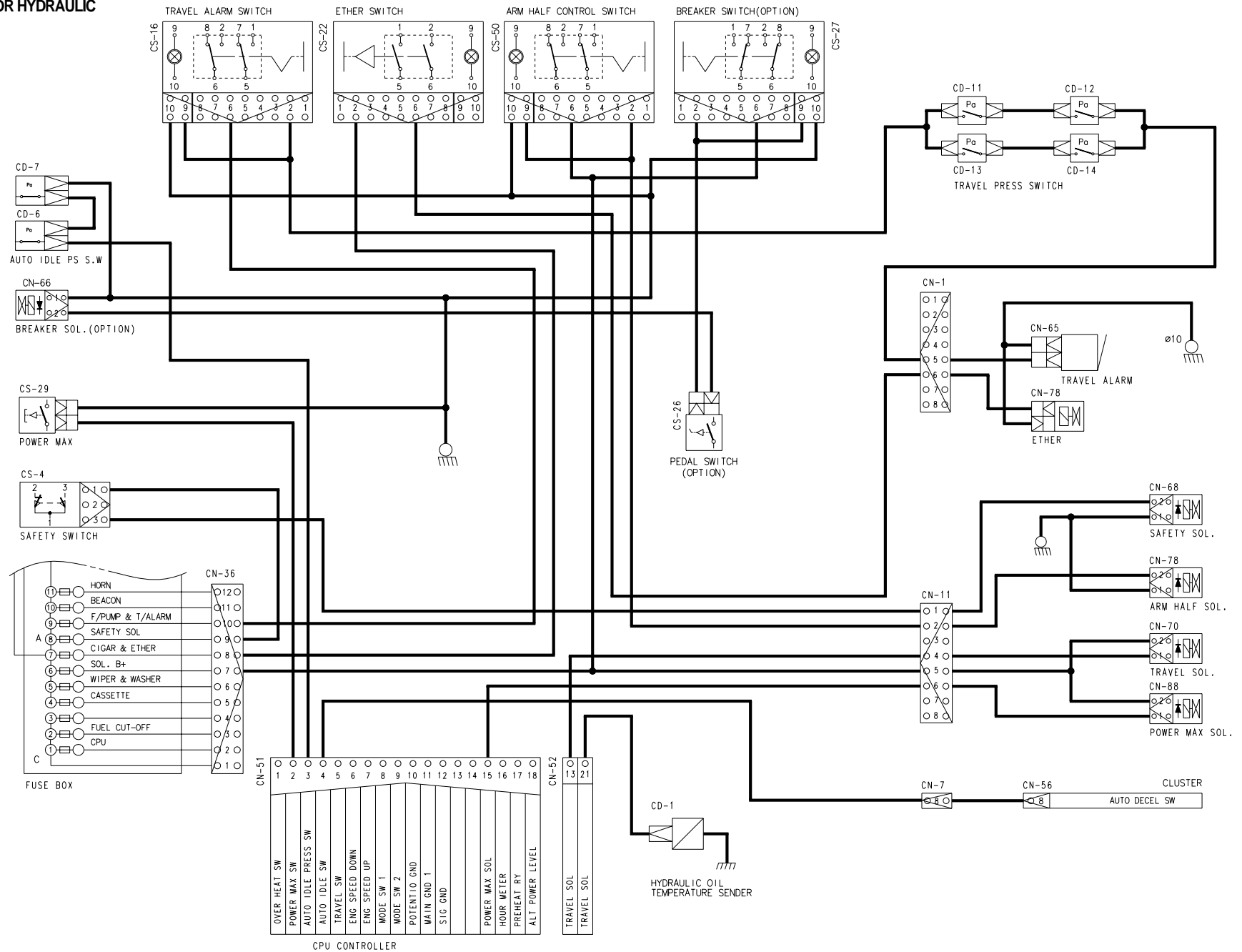

MONITORING CIRCUIT

