

## GROUP 9 ARM HALF FLOW SYSTEM

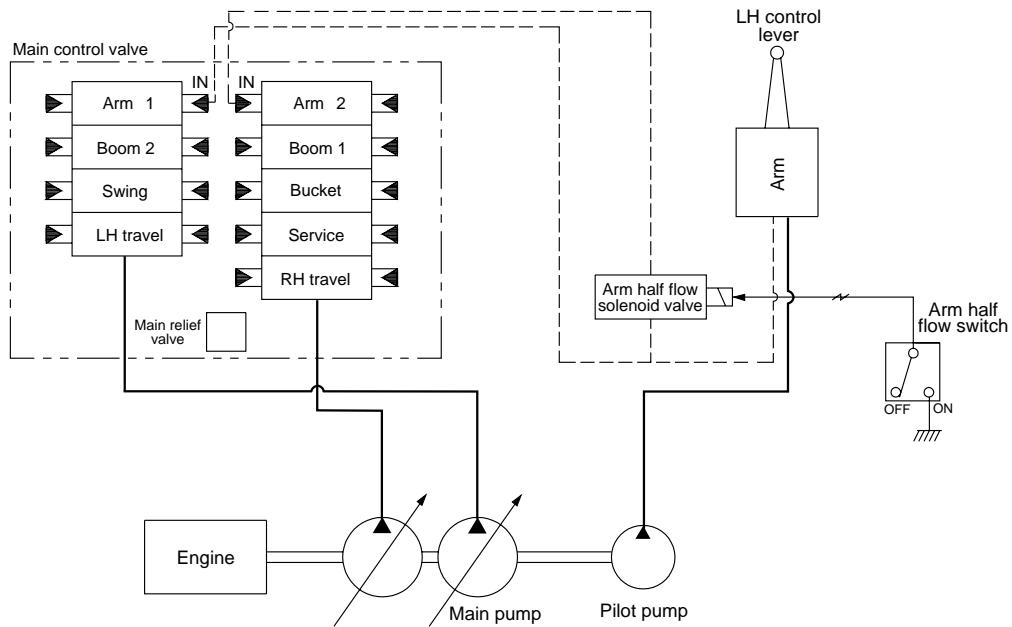

When arm half flow switch is turned ON, the arm half flow solenoid valve is switched to ON and it cancels the junction of the oil flow from two pumps.

This function is useful to fine control of the arm in case of finishing work.

Mode	Boom		Arm			Bucket	Swing	Travel	
	up	down	in		out			LH	RH
H	200	100	100	200	200	100	100	100	100
S									
L									

※ The portion for one pump is taken as 100%.

※ When the arm **out** and bucket are operated simultaneously, the Arm half flow function does not work.