

SECTION 1 GENERAL

Group 1 Safety Hints	1-1
Group 2 Specifications	1-9

SECTION 1 GENERAL

GROUP 1 SAFETY

FOLLOW SAFE PROCEDURE

Unsafe work practices are dangerous. Understand service procedure before doing work; Do not attempt shortcuts.

WEAR PROTECTIVE CLOTHING

Wear close fitting clothing and safety equipment appropriate to the job.

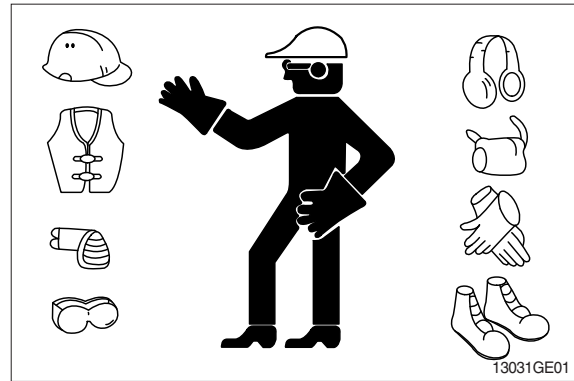

WARN OTHERS OF SERVICE WORK

Unexpected machine movement can cause serious injury. Before performing any work on the excavator, attach a 「Do Not Operate」 tag on the right side control lever.

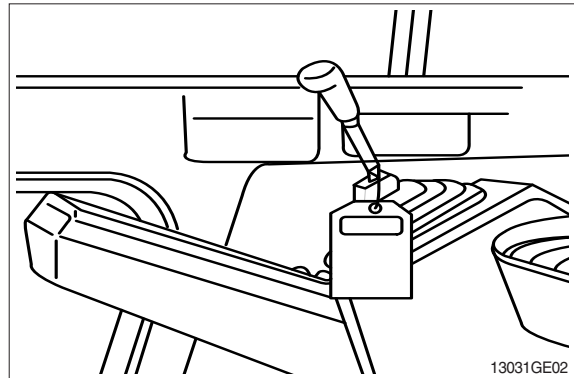

USE HANDHOLDS AND STEPS

Falling is one of the major causes of personal injury. When you get on and off the machine, always maintain a three point contact with the steps and handrails and face the machine. Do not use any controls as handholds. Never jump on or off the machine. Never mount or dismount a moving machine. Be careful of slippery conditions on platforms, steps, and handrails when leaving the machine.

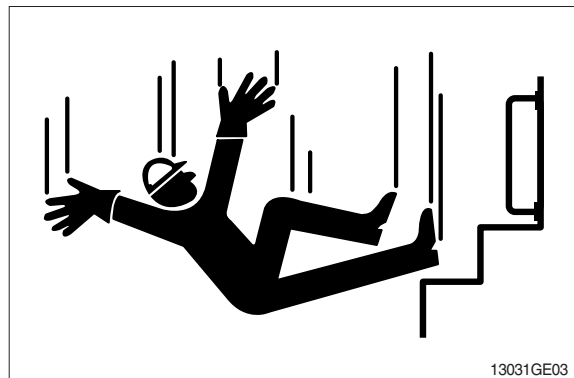

PREPARE FOR EMERGENCIES

Be prepared if a fire starts.

Keep a first aid kit and fire extinguisher handy.

Keep emergency numbers for doctors, ambulance service, hospital, and fire department near your telephone.

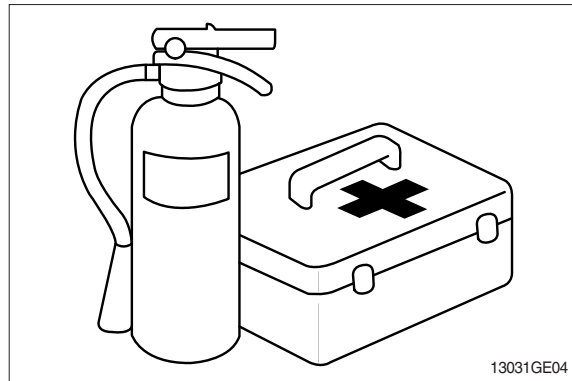

PROTECT AGAINST FLYING DEBRIS

Guard against injury from flying pieces of metal or debris; Wear goggles or safety glasses.

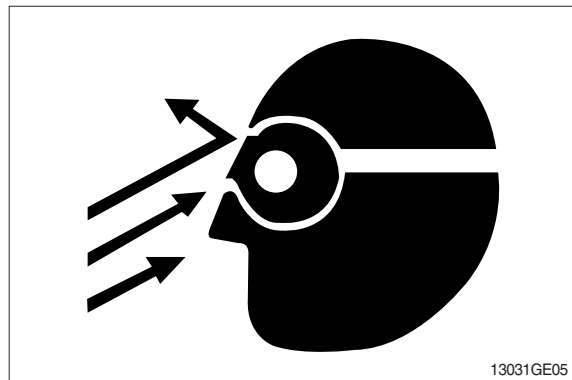

PROTECT AGAINST NOISE

Prolonged exposure to loud noise can cause impairment or loss of hearing.

Wear a suitable hearing protective device such as earmuffs or earplugs to protect against objectionable or uncomfortable loud noises.

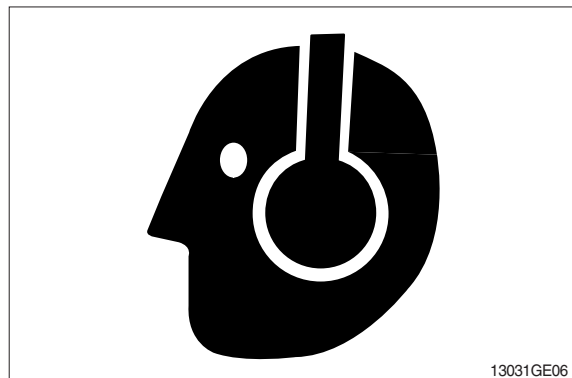

AVOID POWER LINES

Serious injury or death can result from contact with electric lines.

Never move any part of the machine or load closer to electric line than 3m(10ft) plus twice the line insulator length.

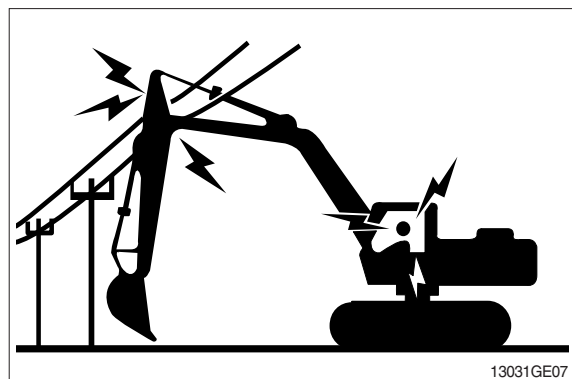

KEEP RIDERS OFF EXCAVATOR

Only allow the operator on the excavator. Keep riders off.

Riders on excavator are subject to injury such as being struck by foreign objects and being thrown off the excavator. Riders also obstruct the operator's view resulting in the excavator being operated in an unsafe manner.

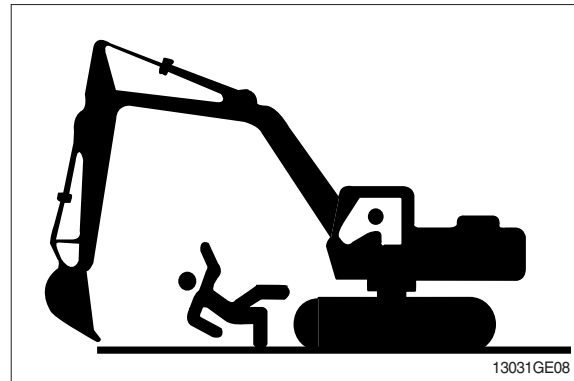

MOVE AND OPERATE MACHINE SAFELY

Bystanders can be run over. Know the location of bystanders before moving, swinging, or operating the machine.

Always keep the travel alarm in working condition. It warns people when the excavator starts to move.

Use a signal person when moving, swinging, or operating the machine in congested areas. Coordinate hand signals before starting the excavator.

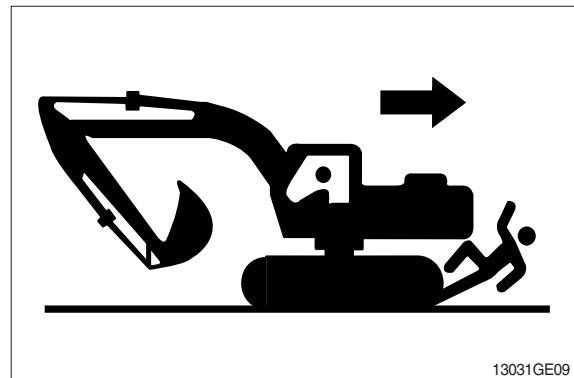

OPERATE ONLY FROM OPERATOR'S SEAT

Avoid possible injury machine damage. Do not start engine by shorting across starter terminals.

NEVER start engine while standing on ground. Start engine only from operator's seat.



PARK MACHINE SAFELY

Before working on the machine:

- Park machine on a level surface.
- Lower bucket to the ground.
- Turn auto idle switch off.
- Run engine at 1/2 speed without load for 2 minutes.
- Turn key switch to OFF to stop engine.
Remove key from switch.
- Move pilot control shutoff lever to locked position.
- Allow engine to cool.

SUPPORT MACHINE PROPERLY

Always lower the attachment or implement to the ground before you work on the machine. If you must work on a lifted machine or attachment, securely support the machine or attachment.

Do not support the machine on cinder blocks, hollow tiles, or props that may crumble under continuous load.

Do not work under a machine that is supported solely by a jack. Follow recommended procedures in this manual.

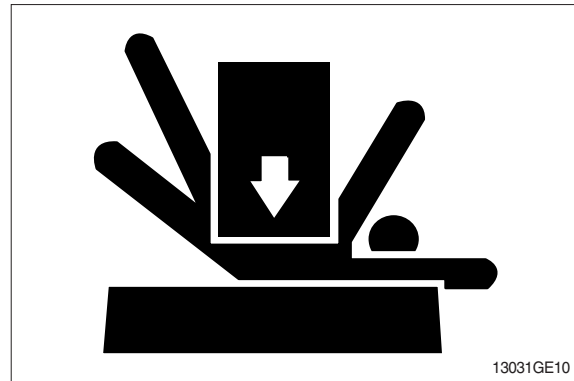

SERVICE COOLING SYSTEM SAFELY

Explosive release of fluids from pressurized cooling system can cause serious burns.

Shut off engine. Only remove filler cap when cool enough to touch with bare hands.

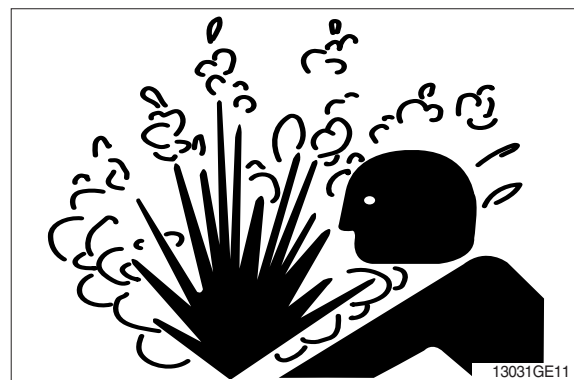

HANDLE FLUIDS SAFELY-AVOID FIRES

Handle fuel with care; It is highly flammable. Do not refuel the machine while smoking or when near open flame or sparks. Always stop engine before refueling machine. Fill fuel tank outdoors.

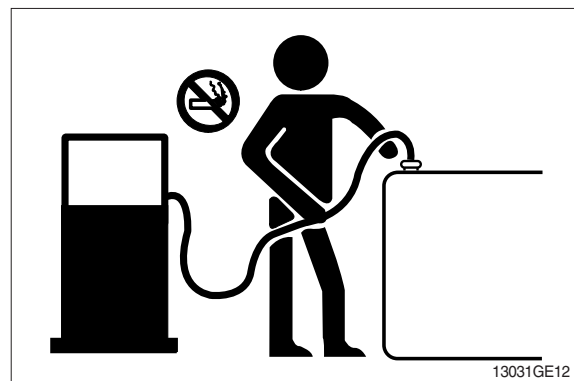

Store flammable fluids away from fire hazards. Do not incinerate or puncture pressurized containers.

Make sure machine is clean of trash, grease, and debris.

Do not store oily rags; They can ignite and burn spontaneously.



BEWARE OF EXHAUST FUMES

Prevent asphyxiation. Engine exhaust fumes can cause sickness or death.

If you must operate in a building, be positive there is adequate ventilation. Either use an exhaust pipe extension to remove the exhaust fumes or open doors and windows to bring enough outside air into the area.

REMOVE PAINT BEFORE WELDING OR HEATING

Avoid potentially toxic fumes and dust.

Hazardous fumes can be generated when paint is heated by welding, soldering, or using a torch.

Do all work outside or in a well ventilated area. Dispose of paint and solvent properly.

Remove paint before welding or heating:

- If you sand or grind paint, avoid breathing the dust. Wear an approved respirator.
- If you use solvent or paint stripper, remove stripper with soap and water before welding. Remove solvent or paint stripper containers and other flammable material from area. Allow fumes to disperse at least 15 minutes before welding or heating.

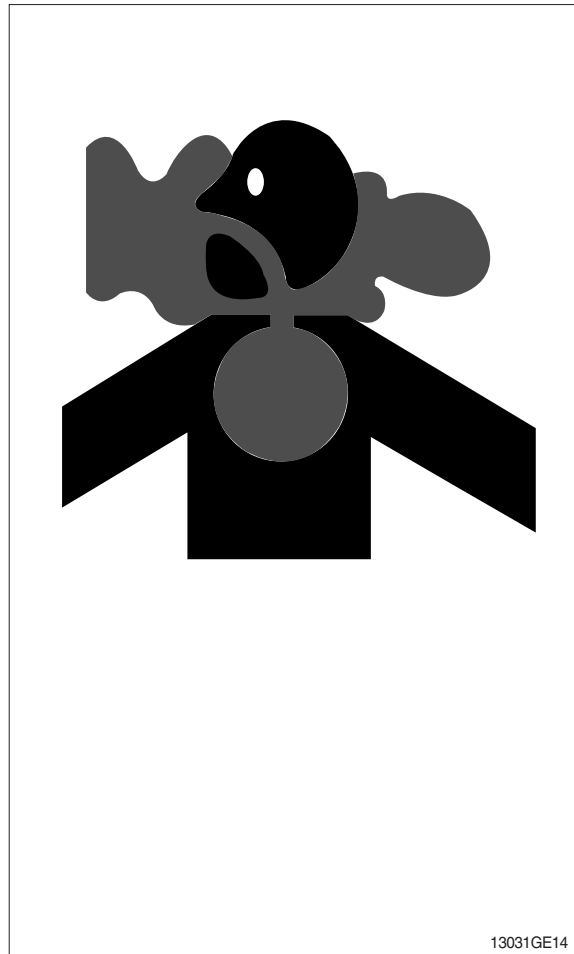

ILLUMINATE WORK AREA SAFELY

Illuminate your work area adequately but safely. Use a portable safety light for working inside or under the machine. Make sure the bulb is enclosed by a wire cage. The hot filament of an accidentally broken bulb can ignite spilled fuel or oil.



SERVICE MACHINE SAFELY

Tie long hair behind your head. Do not wear a necktie, scarf, loose clothing or necklace when you work near machine tools or moving parts. If these items were to get caught, severe injury could result.

Remove rings and other jewelry to prevent electrical shorts and entanglement in moving parts.

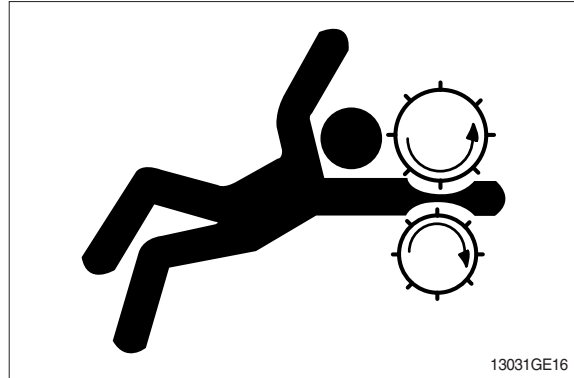

STAY CLEAR OF MOVING PARTS

Entanglements in moving parts can cause serious injury.

To prevent accidents, use care when working around rotating parts.

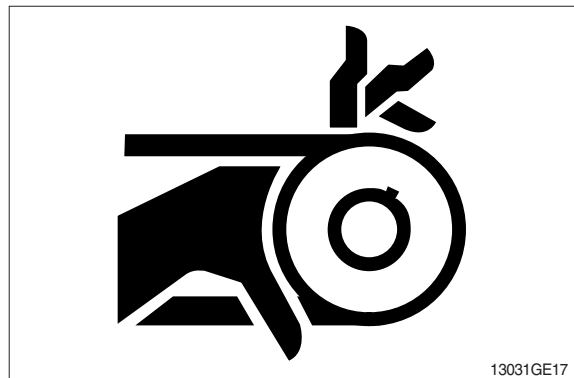

AVOID HIGH PRESSURE FLUIDS

Escaping fluid under pressure can penetrate the skin causing serious injury.

Avoid the hazard by relieving pressure before disconnecting hydraulic or other lines. Tighten all connections before applying pressure.

Search for leaks with a piece of cardboard. Protect hands and body from high pressure fluids.

If an accident occurs, see a doctor immediately. Any fluid injected into the skin must be surgically removed within a few hours or gangrene may result.

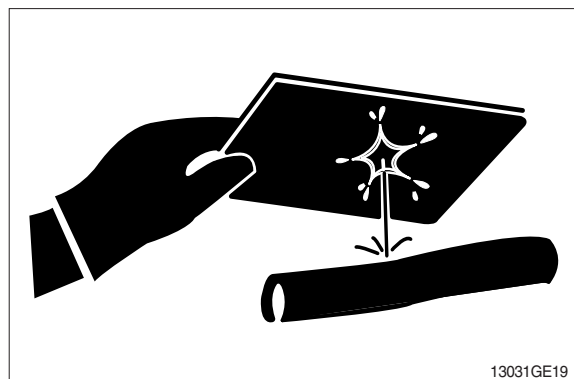

AVOID HEATING NEAR PRESSURIZED FLUID LINES

Flammable spray can be generated by heating near pressurized fluid lines, resulting in severe burns to yourself and bystanders. Do not heat by welding, soldering, or using a torch near pressurized fluid lines or other flammable materials.

Pressurized lines can be accidentally cut when heat goes beyond the immediate flame area. Install fire resisting guards to protect hoses or other materials.



PREVENT BATTERY EXPLOSIONS

Keep sparks, lighted matches, and flame away from the top of battery. Battery gas can explode.

Never check battery charge by placing a metal object across the posts. Use a volt-meter or hydrometer.

Do not charge a frozen battery; It may explode. Warm battery to 16°C (60°F).



PREVENT ACID BURNS

Sulfuric acid in battery electrolyte is poisonous. It is strong enough to burn skin, eat holes in clothing, and cause blindness if splashed into eyes.

Avoid the hazard by:

1. Filling batteries in a well-ventilated area.
2. Wearing eye protection and rubber gloves.
3. Avoiding breathing fumes when electrolyte is added.
4. Avoiding spilling or dripping electrolyte.
5. Use proper jump start procedure.

If you spill acid on yourself:

1. Flush your skin with water.
2. Apply baking soda or lime to help neutralize the acid.
3. Flush your eyes with water for 10-15 minutes. Get medical attention immediately.

If acid is swallowed:

1. Drink large amounts of water or milk.
2. Then drink milk of magnesia, beaten eggs, or vegetable oil.
3. Get medical attention immediately.

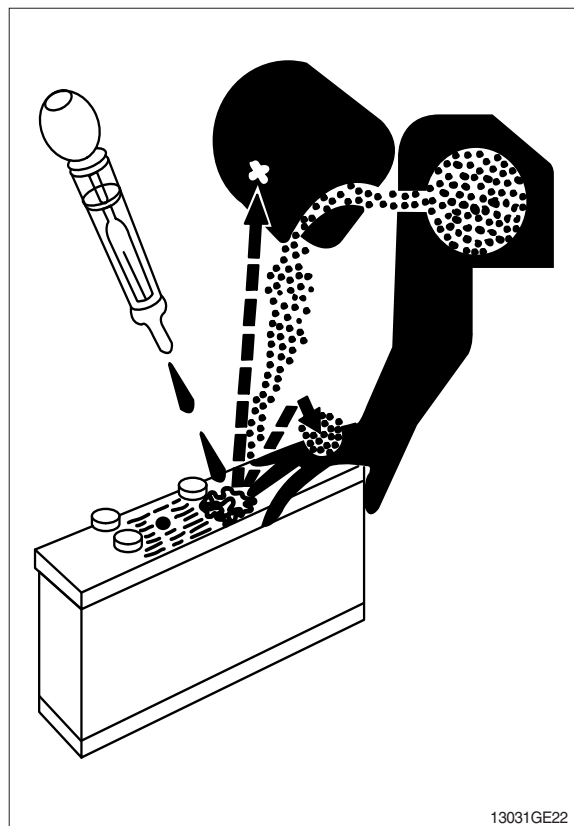

USE TOOLS PROPERLY

Use tools appropriate to the work. Makeshift tools, parts, and procedures can create safety hazards.

Use power tools only to loosen threaded tools and fasteners.

For loosening and tightening hardware, use the correct size tools. DO NOT use U.S. measurement tools on metric fasteners. Avoid bodily injury caused by slipping wrenches.

Use only recommended replacement parts. (See Parts catalogue.)

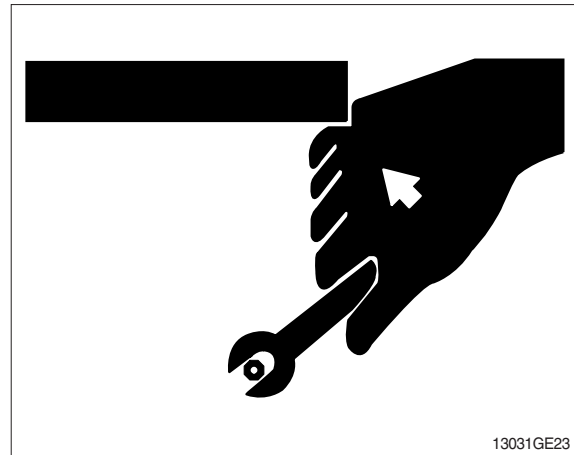

DISPOSE OF FLUIDS PROPERLY

Improperly disposing of fluids can harm the environment and ecology. Before draining any fluids, find out the proper way to dispose of waste from your local environmental agency.

Use proper containers when draining fluids. Do not use food or beverage containers that may mislead someone into drinking from them.

DO NOT pour oil into the ground, down a drain, or into a stream, pond, or lake. Observe relevant environmental protection regulations when disposing of oil, fuel, coolant, brake fluid, filters, batteries, and other harmful waste.

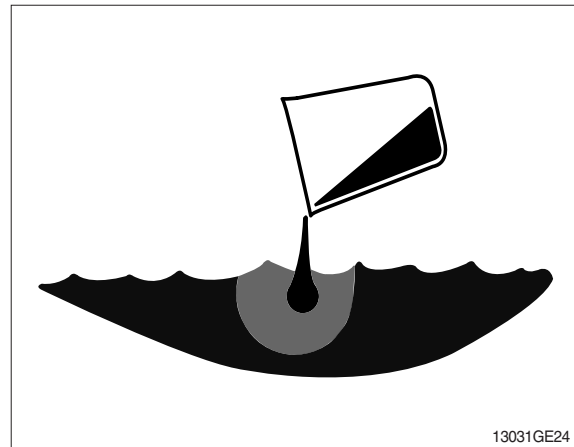

REPLACE SAFETY SIGNS

Replace missing or damaged safety signs. See the machine operator's manual for correct safety sign placement.

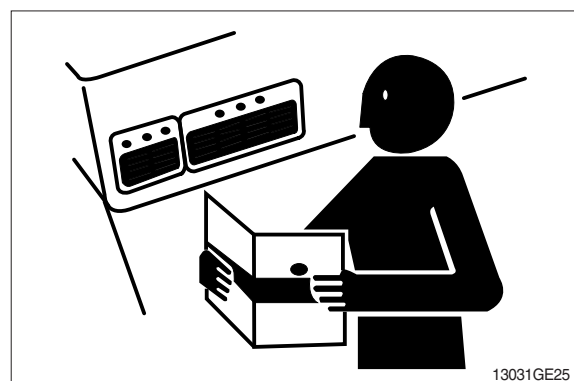

LIVE WITH SAFETY

Before returning machine to customer, make sure machine is functioning properly, especially the safety systems. Install all guards and shields.

GROUP 2 SPECIFICATIONS

1. MAJOR COMPONENT

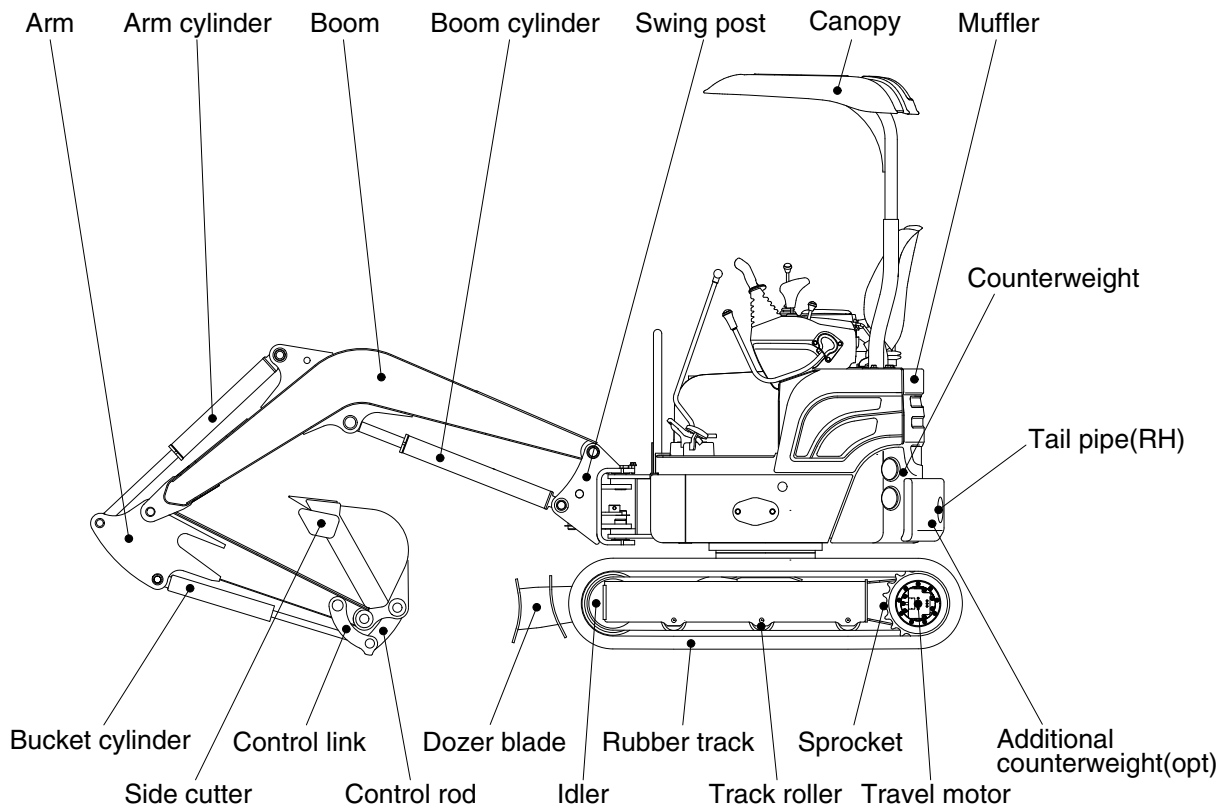
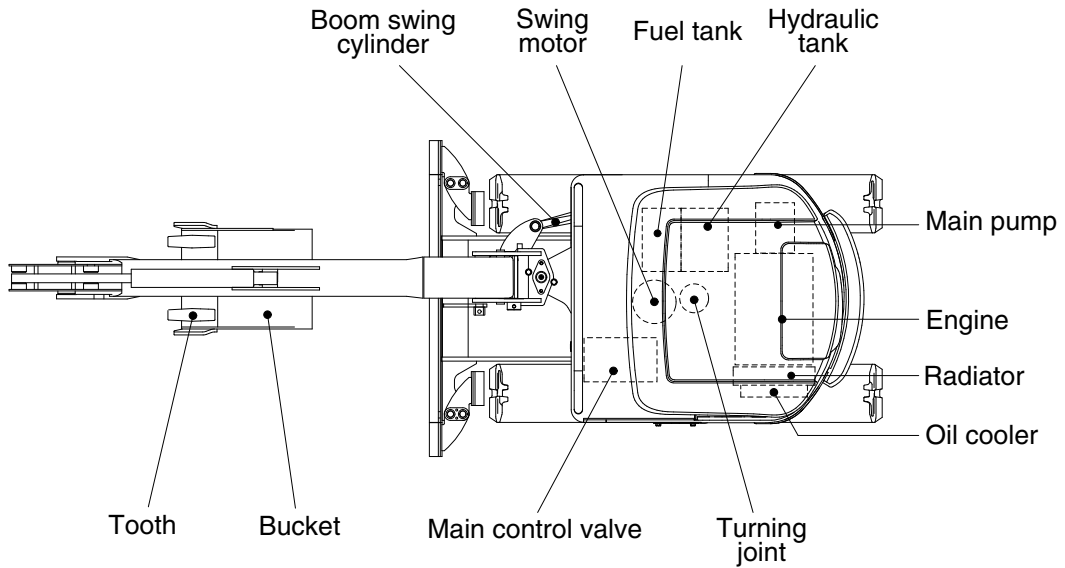

17Z9A2SP01

2. SPECIFICATIONS

1) 1.80 m (5' 11") MONO BOOM, 0.96 m (3' 2") ARM, WITH BOOM SWING POST

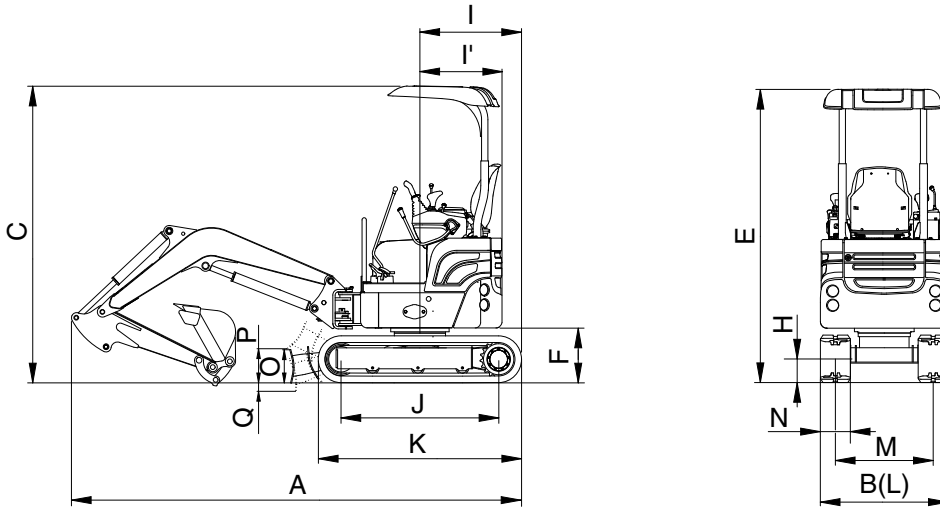

17Z9A2SP02

Description		Unit	Specification
Operating weight (canopy)		kg (lb)	1700 (3750)
Bucket capacity (SAE heaped), standard		m ³ (yd ³)	0.04 (0.05)
Overall length	A	mm (ft-in)	3500 (11' 6")
Overall width, with 230 mm shoe (extension crawler)	B		990~1300 (3' 3" ~ 4' 3")
Overall height	C		2320 (7' 7")
Overall height of canopy	E		2320 (7' 7")
Ground clearance of counterweight	F		440 (1' 5")
Minimum ground clearance	H		170 (6.7")
Rear-end distance	I		645 (2' 1")
Rear-end swing radius	I'		645 (2' 1")
Distance between tumbler rollers	J		1230 (4' 0")
Undercarriage length	K		1590 (5' 3")
Undercarriage width (extension crawler)	L		990~1300 (3' 3" ~ 4' 3")
Track gauge (extension crawler)	M		760~1070 (2' 6" ~ 3' 6")
Track shoe width, standard	N		230 (9")
Height of blade	O		250 (9.8")
Ground clearance of blade up	P		285 (11.2")
Depth of blade down	Q		225 (8.9")
Travel speed (low/high)		km/hr (mph)	2.2/4.1 (1.4/2.5)
Swing speed		rpm	9.5
Gradeability		Degree (%)	30 (58)
Ground pressure 230 mm rubber shoe (canopy)		kgf/cm ² (psi)	0.25 (3.98)
Max traction force		kg (lb)	1420 (3130)

3. WORKING RANGE

1) 1.80 m (5' 11") MONO BOOM WITH BOOM SWING POST

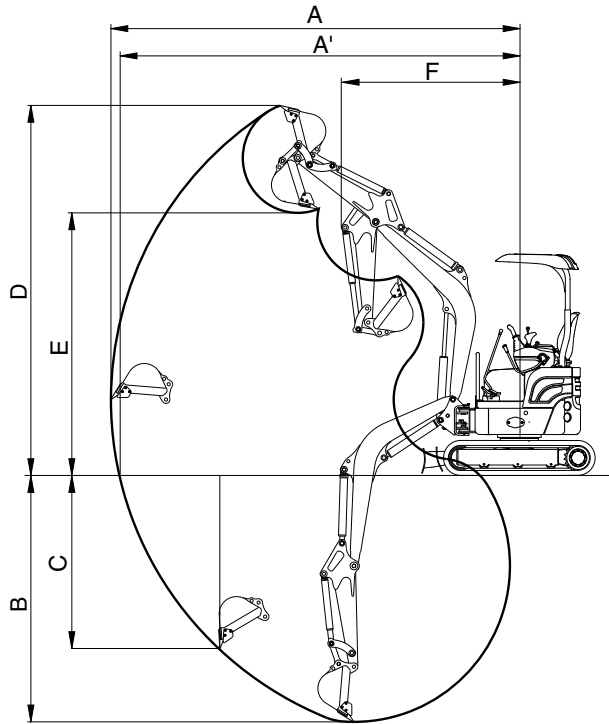

17Z9A2SP03

Description		0.96 m (3' 2") Arm
Max digging reach	A	3900 mm (12' 10")
Max digging reach on ground	A'	3800 mm (12' 6")
Max digging depth	B	2200 mm (7' 3")
Max vertical wall digging depth	C	1320 mm (4' 4")
Max digging height	D	3580 mm (11' 9")
Max dumping height	E	2570 mm (8' 5")
Min swing radius	F	1570 mm (5' 2")
Boom swing radius (left/right)		70°/54°
Bucket digging force	SAE	13.7 kN
		1400 kgf
		2960 lbf
	ISO	15.5 kN
		1580 kgf
		3490 lbf
Arm crowd force	SAE	8.3 kN
		850 kgf
		1880 lbf
	ISO	8.5 kN
		870 kgf
		1920 lbf

4. WEIGHT









Item	kg	lb
Upperstructure assembly	923	2030
Main frame weld assembly	160	353
Engine assembly	75	165
Main pump assembly	13	29
Main control valve assembly	14	31
Swing motor assembly	15	33
Hydraulic oil tank assembly	17	37
Fuel tank assembly	5	11
Boom swing post	35	80
Counterweight	188	414
Canopy assembly	40	88
Front guard	8	18
Lower chassis assembly	550	1210
Track frame weld assembly	185	408
Swing bearing	20	44
Travel motor assembly	18	40
Turning joint	14	31
Track recoil spring	11	24
Idler	15	33
Track roller	5	11
Sprocket	4	9
Rubber track (230 mm)	59	130
Dozer blade assembly	70	154
Front attachment assembly (1.8 m boom, 0.96 m arm, 0.04 m ³ SAE heaped bucket)	227	500
1.8 m boom assembly	70	154
0.96 m arm assembly	35	77
0.04 m ³ SAE heaped bucket	40	90
Boom cylinder assembly	17	37
Arm cylinder assembly	15	33
Bucket cylinder assembly	11	24
Bucket control link assembly	10	22
Dozer cylinder assembly	8	18
Boom swing cylinder assembly	10	22
Extension cylinder assembly	8	18

5. LIFTING CAPACITIES

1) 1.8 m (5' 11") boom, 0.96 m (3' 2") arm equipped with 0.04 m³ (SAE heaped) bucket and 230 mm (9") rubber track, the dozer blade up, track extended with 188 kg (414 lb) counterweight.

·  : Rating over-front

·  : Rating over-side or 360 degree

Load point height		Load radius						At max. reach		
		2.0 m (7.0 ft)		2.5 m (8.0 ft)		3.0 m (10.0 ft)		Capacity		Reach
										m (ft)
3.0 m (10.0 ft)	kg lb							280 620	*290 *640	2.63 (8.6)
2.5 m (8.0 ft)	kg lb			310 680	*310 *680			200 440	210 460	3.13 (10.3)
2.0 m (7.0 ft)	kg lb			300 660	310 680	210 460	220 490	170 370	180 400	3.43 (11.3)
1.5 m (5.0 ft)	kg lb	430 950	440 970	290 640	300 660	210 460	220 490	150 330	160 350	3.60 (11.8)
1.0 m (3.0 ft)	kg lb	400 880	410 900	270 600	290 640	200 440	210 460	140 310	150 330	3.67 (12.0)
0.5 m (2.0 ft)	kg lb	370 820	390 860	260 570	270 600	190 420	200 440	140 310	150 330	3.64 (11.9)
Ground Line	kg lb	360 790	370 820	250 550	270 600	190 420	200 440	150 330	160 350	3.51 (11.5)
-0.5 m (-2.0 ft)	kg lb	360 790	370 820	250 550	260 570	190 420	200 440	170 370	180 400	3.27 (10.7)
-1.0 m (-3.0 ft)	kg lb	360 790	380 840	250 550	270 600			210 460	220 490	2.87 (9.4)
-1.5 m (-5.0 ft)	kg lb	380 840	390 860							

Note 1. Lifting capacity are based on SAE J1097 and ISO 10567.

2. Lifting capacity of the ROBEX series does not exceed 75% of tipping load with the machine on firm, level ground or 87% of full hydraulic capacity.

3. The load point is a hook located on the back of the bucket.

4. *indicates load limited by hydraulic capacity.

※ Lifting capacities are based upon a standard machine conditions.

Lifting capacities will vary with different work tools, ground conditions and attachments.

The difference between the weight of a work tool attachment must be subtracted.

Consult your Hyundai dealer regarding the lifting capacities for specific work tools and attachments.

※ Please be aware of the local regulations and instructions for lifting operations.









▲ Failure to comply to the rated load can cause possible personal injury or property damage.

Make adjustments to the rated load as necessary for non-standard configurations.

2) 1.8 m (5' 11") boom, 0.96 m (3' 2") arm equipped with 0.04 m³ (SAE heaped) bucket and 230 mm (9") rubber track, the dozer blade down, track extended with 188 kg (414 lb) counterweight.

•  : Rating over-front

•  : Rating over-side or 360 degree

Load point height		Load radius						At max. reach		
		2.0 m (7.0 ft)		2.5 m (8.0 ft)		3.0 m (10.0 ft)		Capacity		Reach
										m (ft)
3.0 m (10.0 ft)	kg lb							*290 *640	*290 *640	2.63 (8.6)
2.5 m (8.0 ft)	kg lb			*310 *680	*310 *680			*290 *640	220 490	3.13 (10.3)
2.0 m (7.0 ft)	kg lb			*320 *710	*320 *710	*320 *710	230 510	*300 *660	180 400	3.43 (11.3)
1.5 m (5.0 ft)	kg lb	*450 *990	*450 *990	*380 *840	310 680	*340 *750	230 510	*300 *660	160 350	3.60 (11.8)
1.0 m (3.0 ft)	kg lb	*620 *1370	430 950	*450 *990	300 660	*380 *840	220 490	*310 *680	150 330	3.67 (12.0)
0.5 m (2.0 ft)	kg lb	*740 *1630	400 880	*520 *1150	280 620	*410 *900	210 460	*320 *710	150 330	3.64 (11.9)
Ground Line	kg lb	*790 *1740	390 860	*550 *1210	270 600	*420 *930	210 460	*330 *730	160 350	3.51 (11.5)
-0.5 m (-2.0 ft)	kg lb	*760 *1680	390 860	*540 *1190	270 600	*400 *880	210 460	*330 *730	180 400	3.27 (10.7)
-1.0 m (-3.0 ft)	kg lb	*660 *1460	390 860	*470 *1040	270 600			*320 *710	230 510	2.87 (9.4)
-1.5 m (-5.0 ft)	kg lb	*450 *990	400 880							

- Note
1. Lifting capacity are based on SAE J1097 and ISO 10567.
 2. Lifting capacity of the ROBEX series does not exceed 75% of tipping load with the machine on firm, level ground or 87% of full hydraulic capacity.
 3. The load point is a hook located on the back of the bucket.
 4. *indicates load limited by hydraulic capacity.

6. BUCKET SELECTION GUIDE

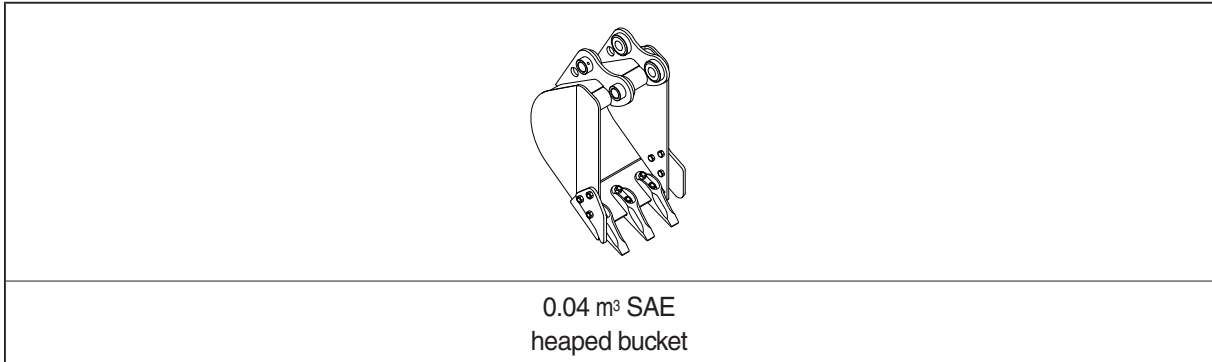

Capacity		Width		Weight	Recommendation
SAE heaped	CECE heaped	Without side cutter	With side cutter		1.8 m (5' 11") boom
					0.96 m (3' 2") arm
0.04m ³ (0.05 yd ³)	0.03 m ³ (0.04 yd ³)	365 mm (14.4")	410 mm (16.1")	40 kg (88 lb)	Applicable for materials with density of 1600 kgf/m ³ (2700 lb /yd ³) or less

7. UNDERCARRIAGE

(1) TRACKS

X-leg type center frame is integrally welded with reinforced box-section track frames. The design includes dry tracks, lubricated rollers, idlers, sprockets, hydraulic track adjusters with shock absorbing springs and assembled track-type tractor shoes with triple grousers.

(2) TYPES OF SHOES

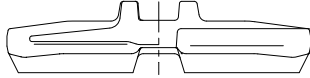
Model	Shapes		Rubber track
			
R17Z-9A	Shoe width	mm (in)	230 (9")
	Operating weight	kg (lb)	1700 (3750)
	Ground pressure	kgf/cm ² (psi)	0.28 (3.98)
	Overall width	mm (ft-in)	1300 (4' 3")

(3) NUMBER OF ROLLERS AND SHOES ON EACH SIDE

Item	Quantity
Track rollers	3 EA

8. SPECIFICATIONS FOR MAJOR COMPONENTS

1) ENGINE

Item	Specification
Model	Kubota D902
Type	4-cycle vertical overhead valve, diesel fuel
Cooling method	Water cooling
Number of cylinders and arrangement	3 cylinders, in-line
Firing order	1-2-3
Combustion chamber type	Swirl chamber type
Cylinder bore × stroke	72 × 73.6 mm (2.83" × 2.90")
Piston displacement	898 cc (54.8 cu in)
Compression ratio	24 : 1
Rated gross horse power (SAE J1995)	16.2 Hp at 2400 rpm (12.1 kW at 2400 rpm)
Maximum torque at 1900 rpm	5.6 kgf · m (36 lbf · ft)
Engine oil quantity	3.7 l (1.0 U.S. gal)
Dry weight	75 kg (165 lb)
High idling speed	2600+ 30 rpm
Low idling speed	1450 ± 25 rpm
Rated fuel consumption	208 g/Hp · hr at 2300 rpm (279 g/kW · hr at 2300 rpm)
Starting motor	12V-1.2 kW
Alternator	12V-40 A
Battery	1 × 12 V × 45 Ah

2) MAIN PUMP (P1, P2+P3)

Item	Specification
Type	Variable displacement tandem axis piston pumps + gear pump
Capacity	2 × 7.5 + 4.5 cc/rev
Rated oil flow	2 × 18.8 + 11.3 l /min (2 × 5 + 3 U.S. gpm / 2 × 4.1 + 2.5 U.K. gpm)
Rated speed	2500 rpm

3) PILOT PUMP (P4)

Item	Specification
Type	Fixed displacement gear pump single stage
Capacity	2.7 cc/rev
Rated oil flow	6.8 l /min (1.8 U.S. gpm / 1.5 U.K. gpm)

4) MAIN CONTROL VALVE

Item	Specification
Type	Sectional, 9 spools (12 blocks)
Operating method	Hydraulic pilot system
Main relief valve pressure (P1, P2 / P3)	210 kgf/cm ² (2990 psi) / 170 kgf/cm ² (2420 psi)
Overload relief valve pressure	230 kgf/cm ² (3270 psi)

5) SWING MOTOR

Item	Specification
Type	Fixed displacement orbit motor
Capacity	19.5 cc/rev
Relief pressure	135 kgf/cm ² (1920 psi)

6) TRAVEL MOTOR

Item	Specification
Type	Variable displacement axial piston motor
Relief pressure	210 kgf/cm ² (2990 psi)
Reduction gear type	2-stage planetary

7) CYLINDER

Item		Specification
Boom cylinder	Bore dia × Rod dia × Stroke	∅ 60 × ∅ 40 × 440 mm
	Cushion	Extend only
Arm cylinder	Bore dia × Rod dia × Stroke	∅ 60 × ∅ 40 × 353 mm
	Cushion	Extend and retract
Bucket cylinder	Bore dia × Rod dia × Stroke	∅ 55 × ∅ 35 × 320 mm
	Cushion	-
Boom swing cylinder	Bore dia × Rod dia × Stroke	∅ 55 × ∅ 30 × 355 mm
	Cushion	-
Dozer cylinder	Bore dia × Rod dia × Stroke	∅ 65 × ∅ 30 × 115 mm
	Cushion	-
Extension cylinder	Bore dia × Rod dia × Stroke	∅ 55 × ∅ 30 × 310 mm
	Cushion	-

※ Discoloration of cylinder rod can occur when the friction reduction additive of lubrication oil spreads on the rod surface.

※ Discoloration does not cause any harmful effect on the cylinder performance.

8) BUCKET

Item	Capacity		Tooth quantity	Width	
	SAE heaped	CECE heaped		Without side cutter	With side cutter
Standard	0.04 m ³ (0.05 yd ³)	0.03 m ³ (0.04 yd ³)	3	365 mm (14.4")	410 mm (16.1")

9. RECOMMENDED OILS

HYUNDAI genuine lubricating oils have been developed to offer the best performance and service life for your equipment. These oils have been tested according to the specifications of HYUNDAI and, therefore, will meet the highest safety and quality requirements.

We recommend that you use only HYUNDAI genuine lubricating oils and grease officially approved by HYUNDAI.

Service point	Kind of fluid	Capacity ℓ (U.S. gal)	Ambient temperature °C (°F)									
			-50 (-58)	-30 (-22)	-20 (-4)	-10 (14)	0 (32)	10 (50)	20 (68)	30 (86)	40 (104)	
Engine oil pan	Engine oil	3.7 (1.0)	★SAE 5W-40					SAE 30				
			SAE 10W				SAE 10W-30					
			SAE 15W-40									
Final drive	Gear oil	0.33×2 (0.99×2)	★SAE 75W-90					SAE 85W-140				
Hydraulic tank	Hydraulic oil	Tank: 13 (3.4) System: 23 (6.1)	★ISO VG 15					ISO VG 46, HBHO VG 46★ ³				
											ISO VG 68	
Fuel tank	Diesel fuel★ ¹	20 (5.3)	★ASTM D975 NO.1					ASTM D975 NO.2				
Fitting (grease nipple)	Grease	As required	★NLGI NO.1					NLGI NO.2				
Radiator (reservoir tank)	Mixture of antifreeze and soft water★ ²	3.5 (0.9)	Ethylene glycol base permanent type (50 : 50)									
			★Ethylene glycol base permanent type (60 : 40)									

SAE : Society of Automotive Engineers
API : American Petroleum Institute
ISO : International Organization for Standardization
NLGI : National Lubricating Grease Institute
ASTM : American Society of Testing and Material
UTTO : Universal Tractor Transmission Oil

★ : Cold region
 Russia, CIS, Mongolia
 ★¹ : Ultra low sulfur diesel
 - sulfur content ≤ 15 ppm
 ★² : Soft water
 City water or distilled water
 ★³ : Hyundai Bio Hydraulic Oil
 - For more information, contact HYUNDAI dealers.

※ Using any lubricating oils other than HYUNDAI genuine products may lead to a deterioration of performance and cause damage to major components.

※ Do not mix HYUNDAI genuine oil with any other lubricating oil as it may result in damage to the systems of major components.

※ Do not use any engine oil other than that specified above, as it may clog the diesel particulate filter(DPF).

※ For HYUNDAI genuine lubricating oils and grease for use in regions with extremely low temperatures, please contact HYUNDAI dealers.