

GROUP 2 MODE SELECTION SYSTEM

1. POWER MODE SELECTION SYSTEM

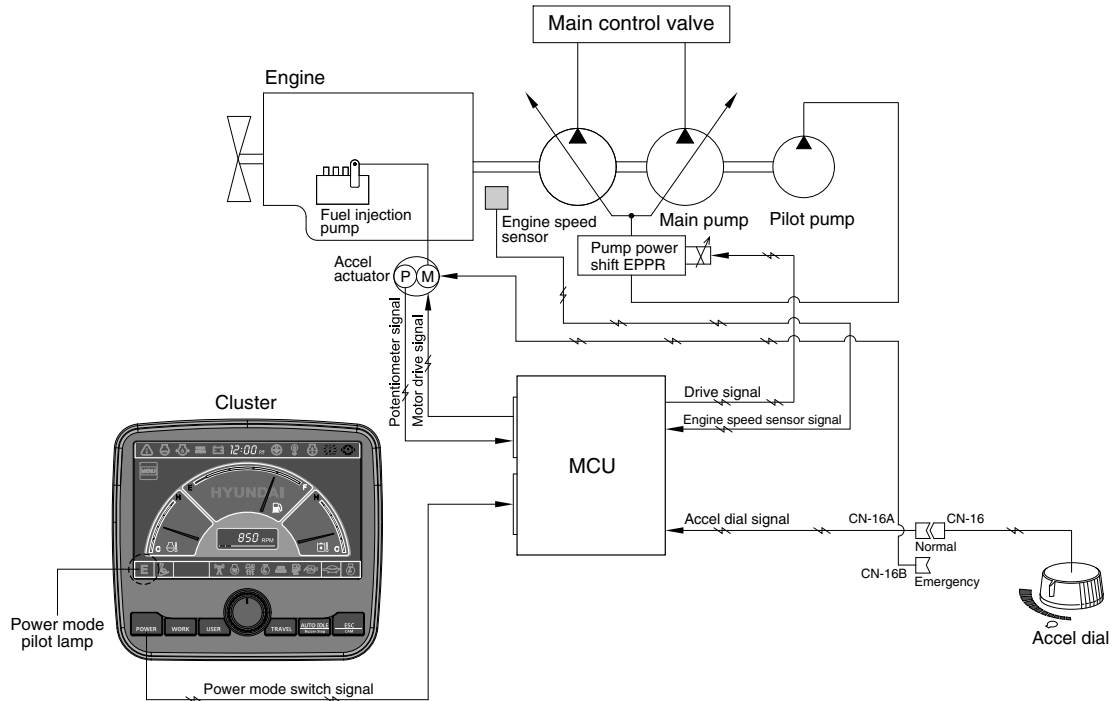

1409S5MS02

Mode selection system (micro computer based electro-hydraulic pump and engine mutual control system) optimizes the engine and pump performance.

The combination of 3 power modes (P, S, E) and accel dial position (10 set) makes it possible to use the engine and pump power more effectively corresponding to the work conditions from a heavy and great power requesting work to a light and precise work.

Power mode	Application	Engine rpm				Power shift by EPPR valve			
		Standard		Option		Standard		Option	
		Unload	Load	Unload	Load	Current (mA)	Pressure (kgf/cm ²)	Current (mA)	Pressure (kgf/cm ²)
P	Heavy duty power	2100±50	1900±50	2200±50	2000±50	330±30	10(5)±2.5	250±30	5±3
S	Standard power	1900±50	1700±50	2000±50	1800±50	340±30	11(8)±2.5	290±30	8±3
E	Economy operation	1800±50	1600±50	1900±50	1700±50	365±30	13(8)±2.5	330±30	10±3
AUTO DECEL	Engine deceleration	1150±100	-	1150±100	-	700±30	38±3	700±30	38±3
One touch decel	Engine quick deceleration	1000±100	-	1000±100	-	700±30	38±3	700±30	38±3
KEY START	Key switch start position	1000±100	-	1000±100	-	700±30	38±3	700±30	38±3

※ Power shift (Standard/Option) can be changed by "Service menu" in "Management" on the cluster.

※ () values of pressure are on load status.

2. WORK MODE SELECTION SYSTEM

Work mode consists of the general operation (bucket) and the optional attachment (breaker, crusher).

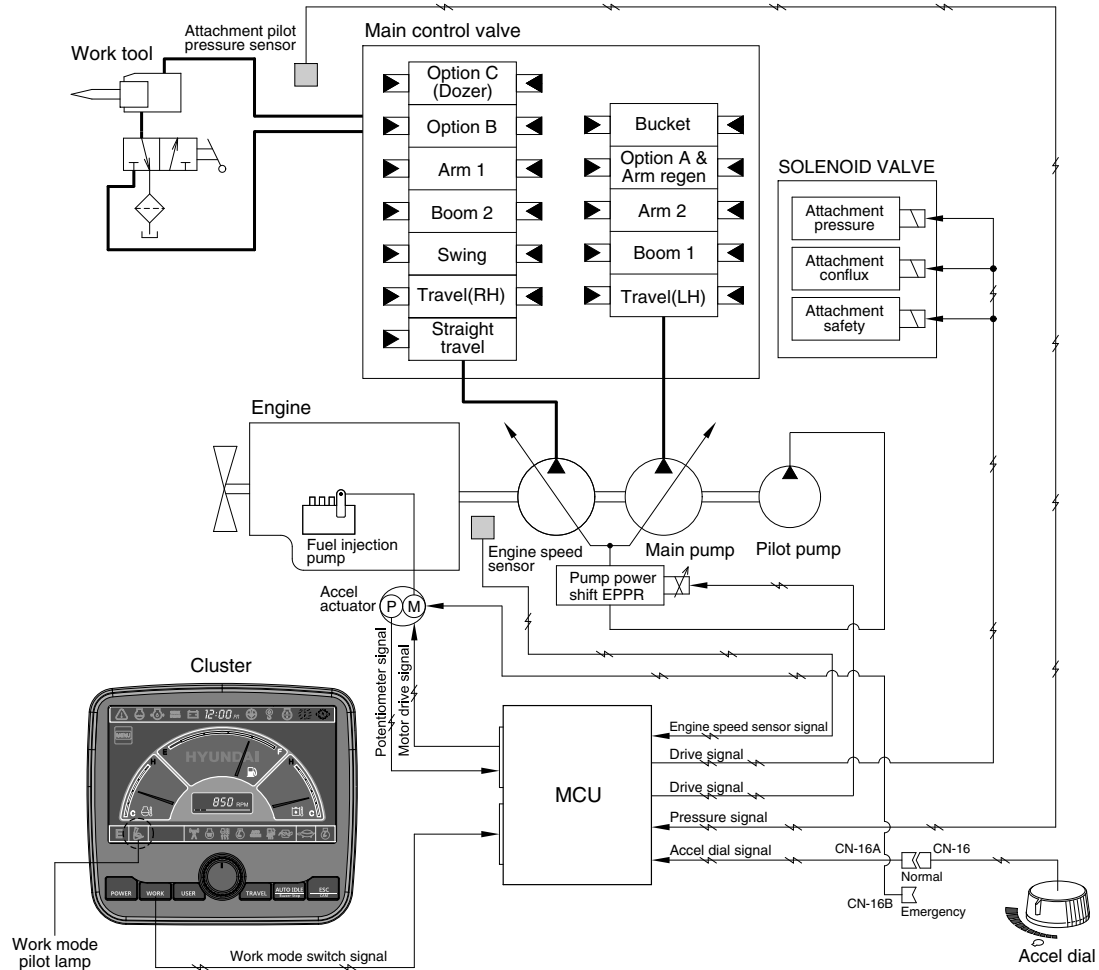

1409S5MS03

1) GENERAL WORK MODE (bucket)

This mode is used to general digging work.

2) ATT WORK MODE (breaker, crusher)

It controls the pump flow and system pressure according to the operation of breaker or crusher.

Description	General mode	Work tool	
	Bucket	Breaker	Crusher
Attachment safety solenoid	OFF	ON	ON
Attachment pressure solenoid	OFF	OFF	ON
Attachment conflux solenoid	OFF	OFF	ON/OFF
Attachment flow EPPR current	100 mA	100~700 mA	100~700 mA

3. USER MODE SELECTION SYSTEM

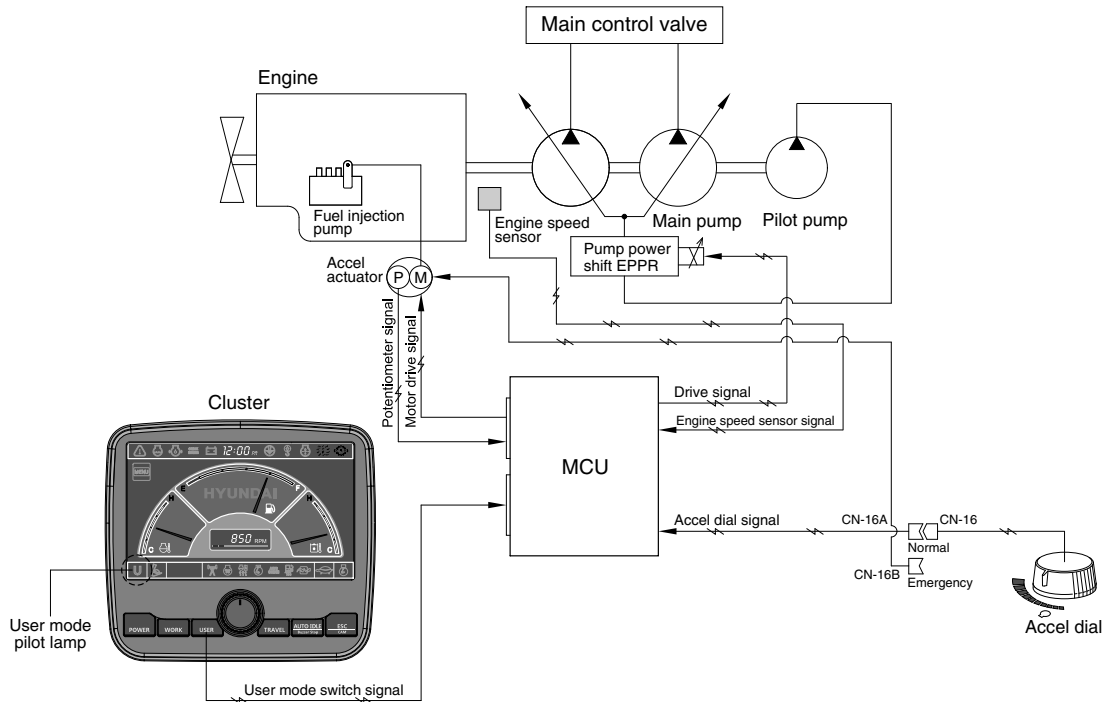

1409S5MS04

1) High idle rpm, auto idle rpm and EPPR pressure can be adjusted and memorized in the U-mode.

2) LCD segment vs parameter setting

Step ()	Engine speed (rpm)	Idle speed (rpm)	Power shift (bar)
1	1500	★1000	0
2	1600	1050	3
3	1700	1100	6
4	1800	1150 (decel rpm)	9
5	1900	1200	12
6	2000	1250	16
7	2050	1300	20
8	2100	1350	26
9	2150	1400	32
10	2200	1450	38

★ : Low idle and one touch decel