

GROUP 4 HYDRAULIC SYSTEM

1. HYDRAULIC COMPONENTS MOUNTING 1

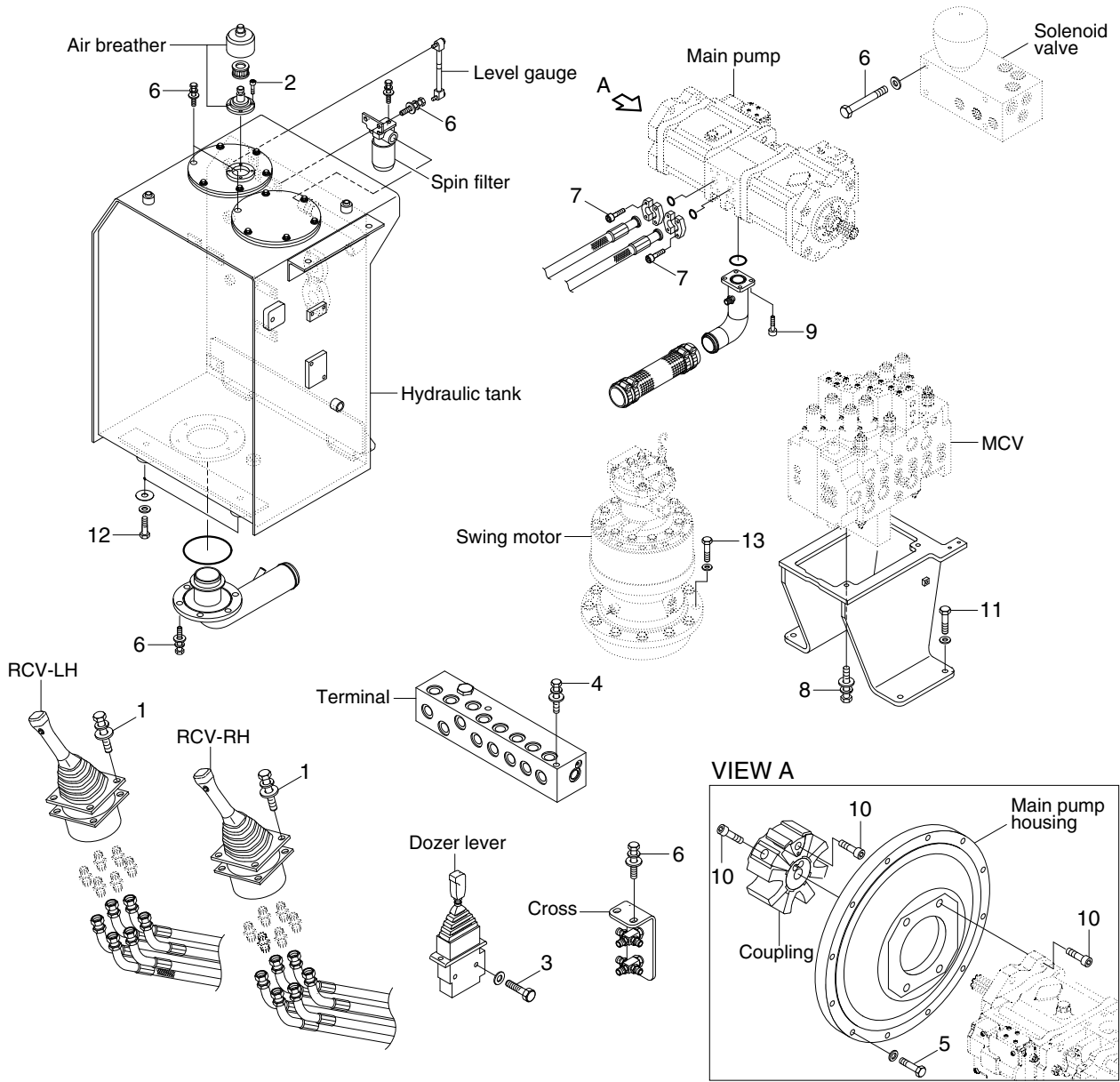

1609S9CM05

·Tightening torque

Item	Size	kgf·m	lbf·ft
1	M 6×1.0	1.05±0.2	7.6±1.45
2	M 6×1.0	1.44±0.3	10.4±2.2
3	M 8×1.25	2.5±0.5	18.1±3.6
4	M 8×1.25	4.05±0.8	29.3±5.8
5	M10×1.5	6.0±0.3	43.4±10.8
6	M10×1.5	6.9±1.4	49.9±10.1
7	M10×1.5	8.27±1.7	59.8±12.3

Item	Size	kgf·m	lbf·ft
8	M12×1.75	12.2±1.3	88.2±9.4
9	M12×1.75	14.7±2.2	106±15.9
10	M16×2.0	22±1.0	159±7.2
11	M16×2.0	29.7±4.5	215±32.5
12	M20×2.5	46±5.1	333±36.9
13	M20×2.5	57.9±8.7	419±62.9
-	-	-	-

2. HYDRAULIC COMPONENTS MOUNTING 2

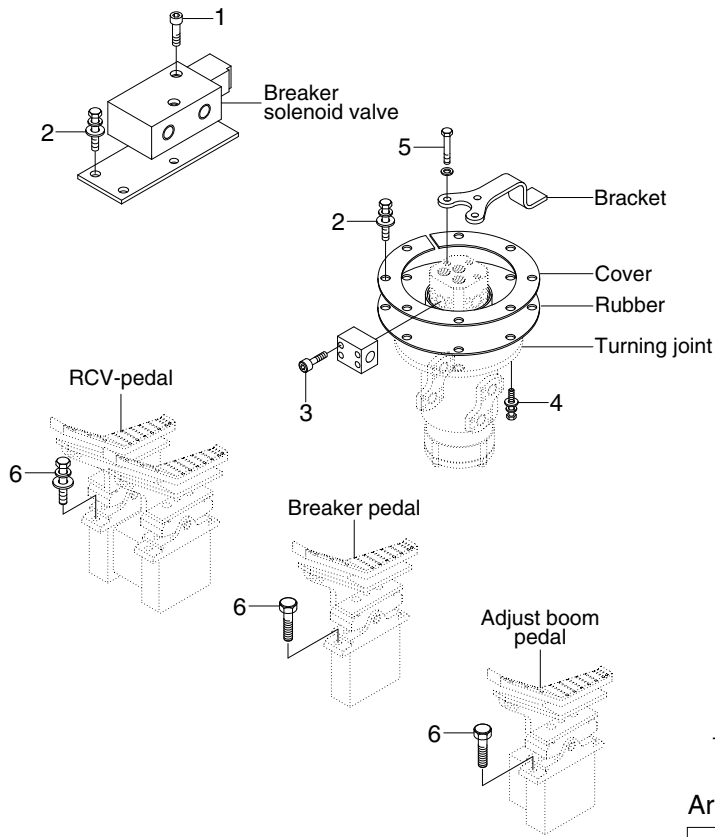

Solenoid valve

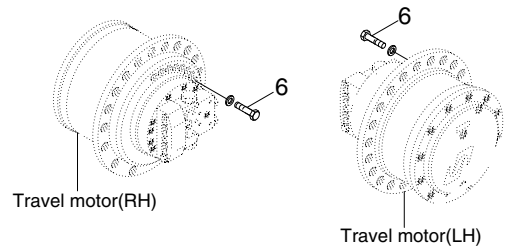
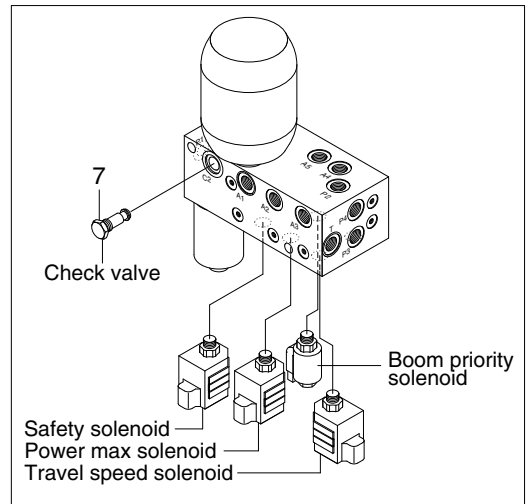

Arm safety lock system

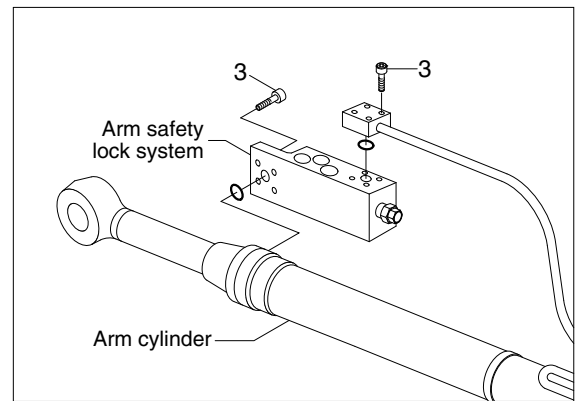

Boom safety lock system

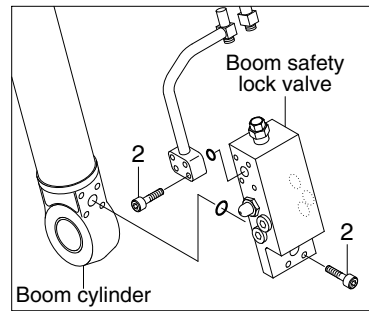

1609SB9CM06

Tightening torque

Item	Size	kgf·m	lbf·ft
1	M 8×1.25	3.43±0.7	24.8±5.1
2	M10×1.5	6.9±1.4	49.9±10.1
3	M10×1.5	8.27±1.7	59.8±12.3
4	M12×1.75	12.3±1.3	88.9±9.4

Item	Size	kgf·m	lbf·ft
5	M14×2.0	19.6±2.9	142±21.0
6	M16×2.0	23.0±2.5	166±18.1
7	-	4.0±0.8	28.9±5.8
-	-	-	-

3. HYDRAULIC COMPONENTS MOUNTING 3

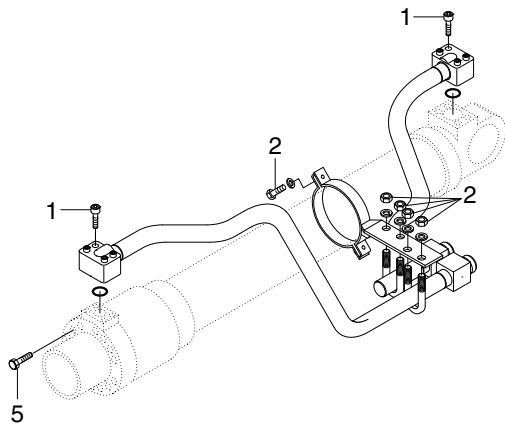

BOOM CYLINDER

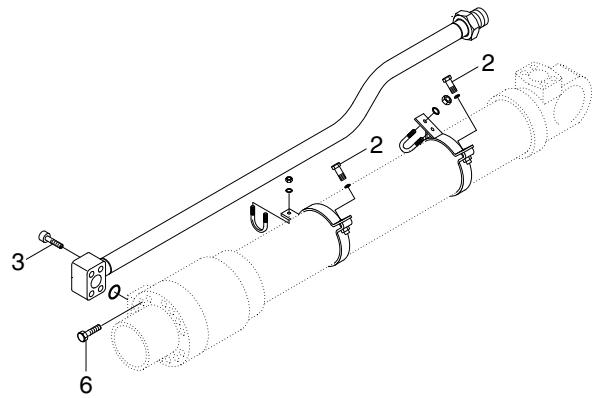

ARM CYLINDER

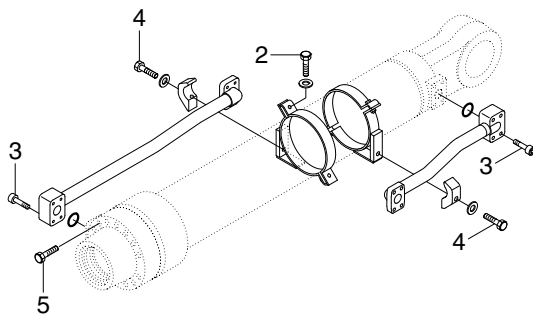

BUCKET CYLINDER

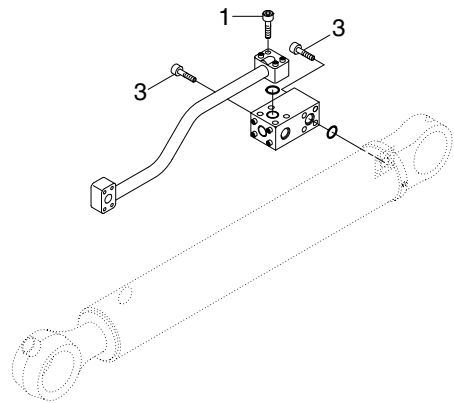

DOZER BLADE CYLINDER

1609S9CM07

·Tightening torque

Item	Size	kgf·m	lbf·ft
1	M 8×1.25	2.7±0.3	19.5±2.2
2	M10×1.5	3.2±0.3	23.1±2.2
3	M10×1.5	5.4±0.5	39.1±3.6

Item	Size	kgf·m	lbf·ft
4	M12×1.75	9.3±1.9	67.3±13.7
5	M14×2.0	15±2.0	108±14.5
6	M16×2.0	23±2.0	166±14.5