

GROUP 2 ENGINE SYSTEM

1. ENGINE AND ACCESSORIES MOUNTING

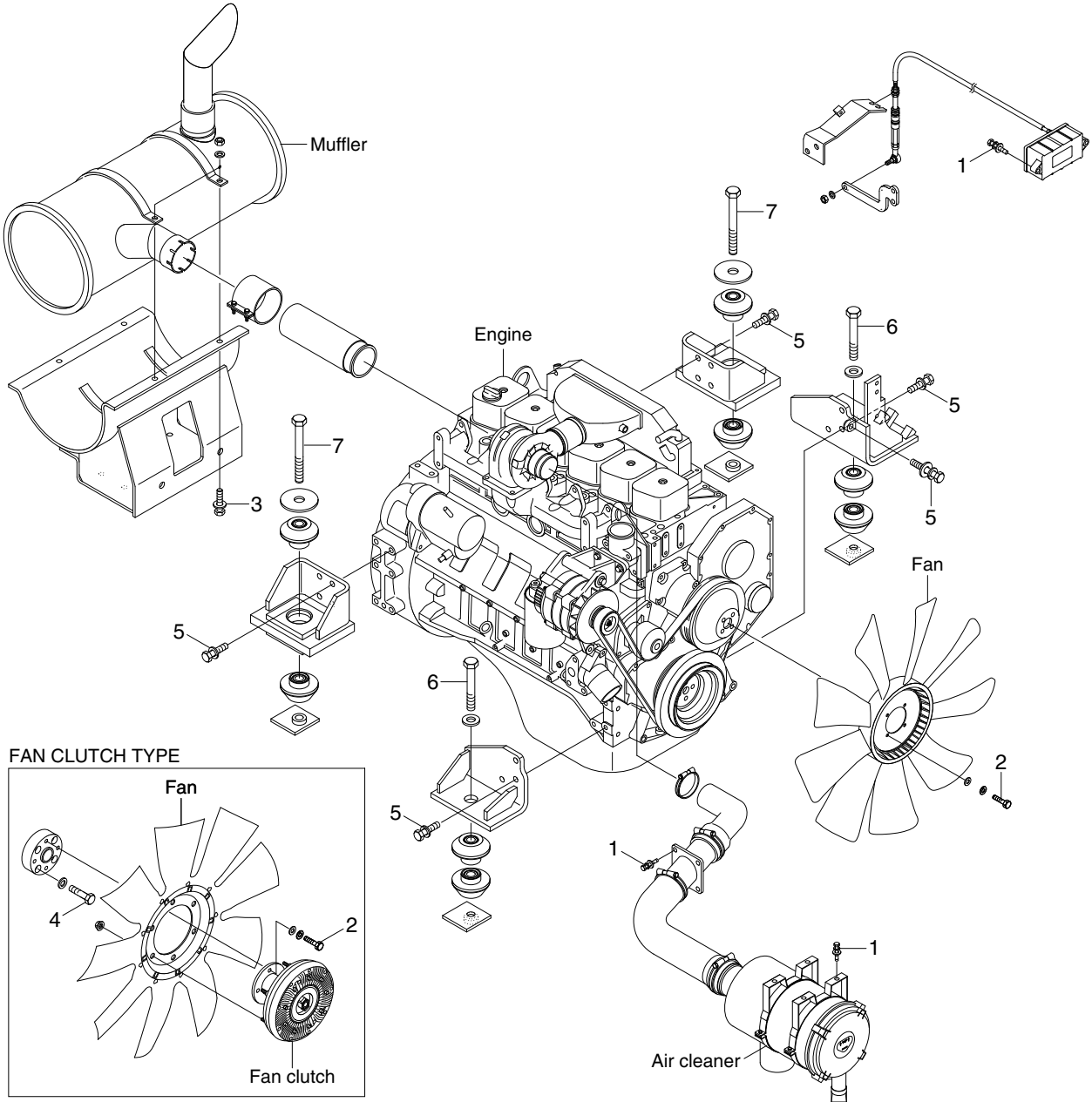

1609SB9CM01

·Tightening torque

Item	Size	kgf·m	lbf·ft
1	M 8×1.25	2.5±0.5	18.1±3.6
2	M10×1.5	4.4±0.5	31.8±3.6
3	M10×1.5	6.9±1.4	49.9±10.1
4	M10×1.5	8.27±1.7	59.8±12.3

Item	Size	kgf·m	lbf·ft
5	M12×1.75	10.0±1.0	72.3±7.2
6	M20×2.5	55±3.5	398±25.3
7	M24×3.0	90±7.0	651±50.6
-	-	-	-

2. COOLING SYSTEM AND FUEL TANK MOUNTING

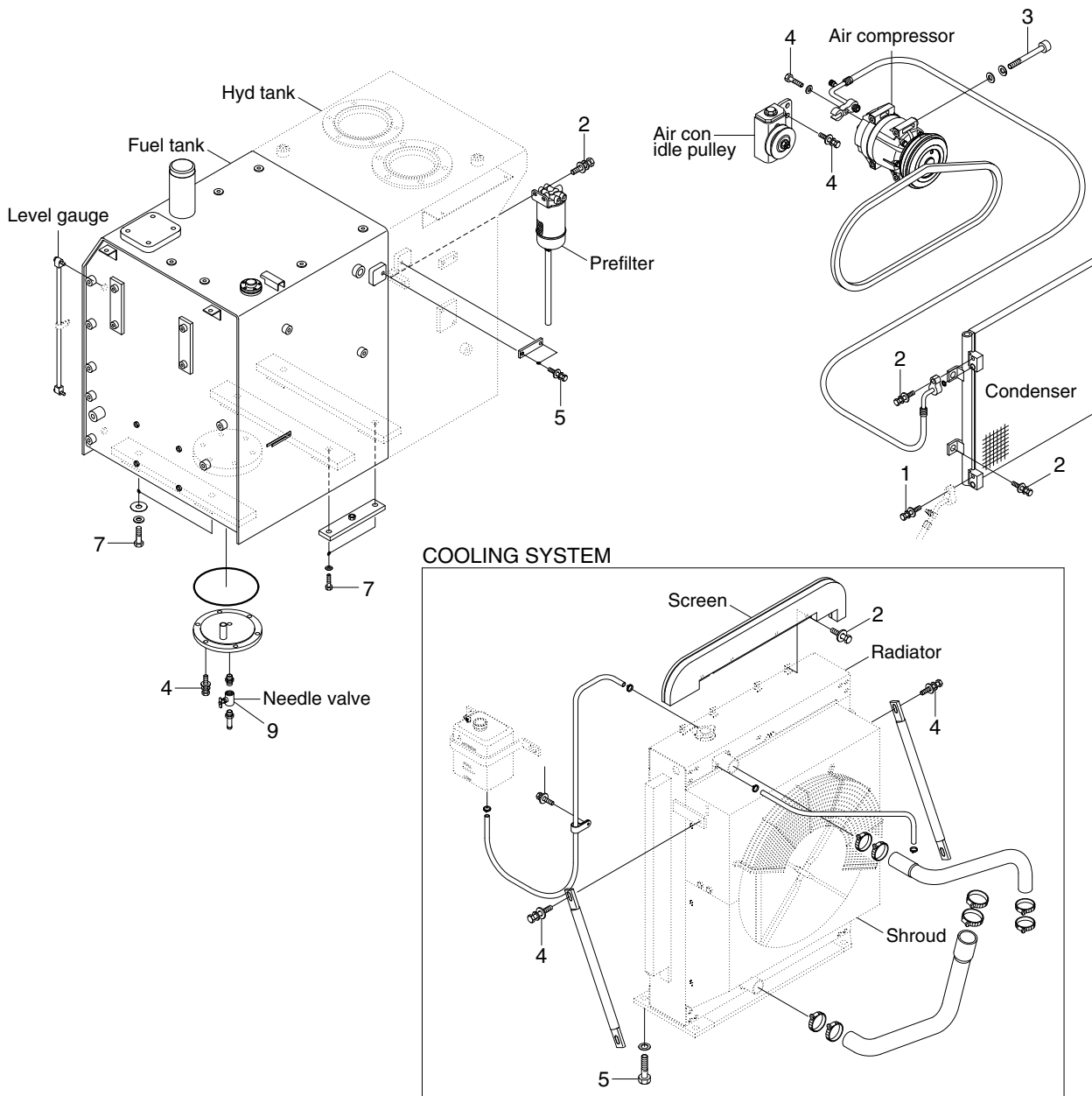

1609SB9CM02

Tightening torque

Item	Size	kgf·m	lbf·ft
1	M 6×1.0	1.05±0.2	7.6±1.45
2	M8×1.25	2.5±0.5	18.1±3.6
3	M8×1.25	4.05±0.8	29.3±5.8
4	M10×1.5	6.9±1.4	49.9±10.1

Item	Size	kgf·m	lbf·ft
5	M12×1.75	12.8±3.0	92.6±21.7
6	M16×2.0	29.7±4.5	215±32.5
7	M20×2.5	46±5.1	333±36.9
8	-	2.3±0.6	16.6±4.3