

# GROUP 4 HYDRAULIC SYSTEM

## 1. HYDRAULIC COMPONENTS MOUNTING 1

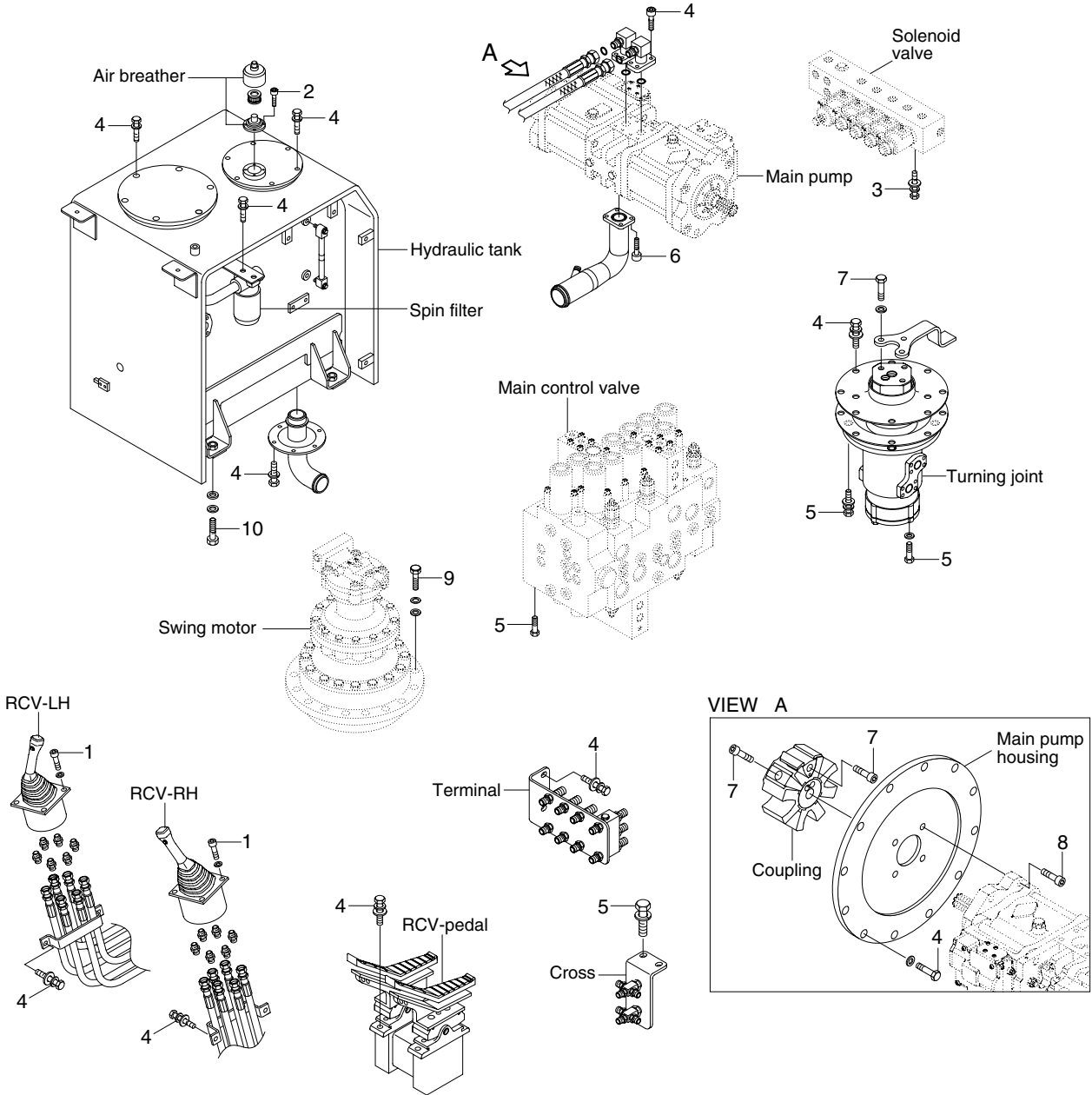

• Tightening torque

1607A9CM05

Item	Size	kgf · m	lbf · ft
1	M 6×1.0	1.05±0.2	7.6±1.45
2	M 6×1.0	1.44±0.3	10.4±2.2
3	M 8×1.25	2.5±0.5	18.1±3.6
4	M10×1.5	6.9±1.4	49.9±10.1
5	M12×1.75	12.2±1.3	88.2±9.4

Item	Size	kgf · m	lbf · ft
6	M12×1.75	14.7±2.2	106±15.9
7	M14×2.0	19.6±2.9	142±21
8	M16×2.0	22.5±0.5	163±3.6
9	M20×2.5	57.9±8.7	419±62.9
10	M20×2.5	45±5.1	325±36.9

## 2. HYDRAULIC COMPONENTS MOUNTING 2

Double acting attachment piping

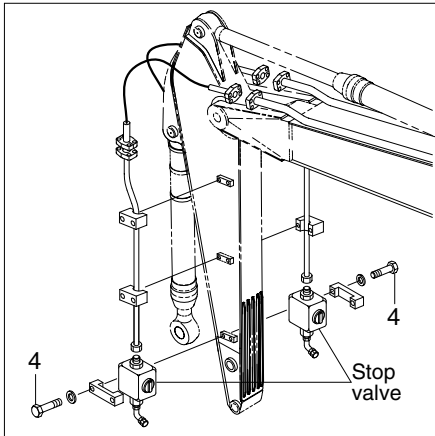

Arm safety lock system

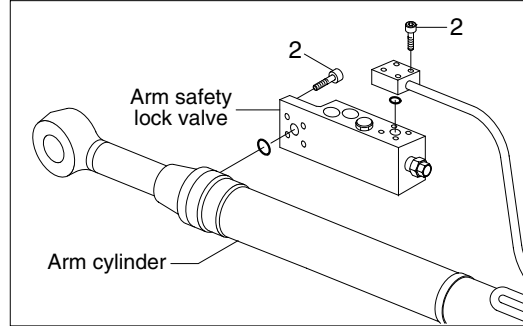

Boom safety lock system

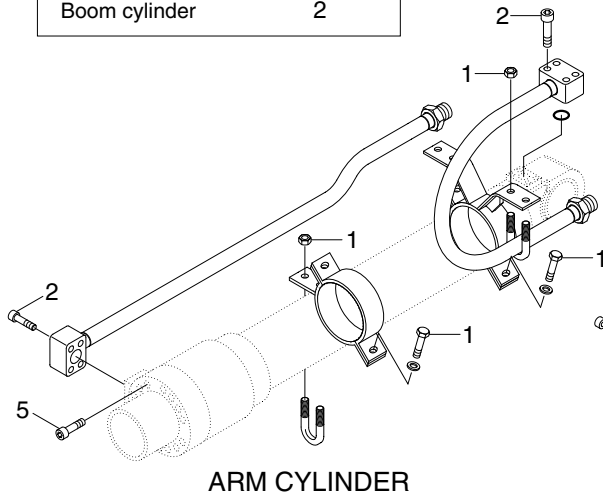
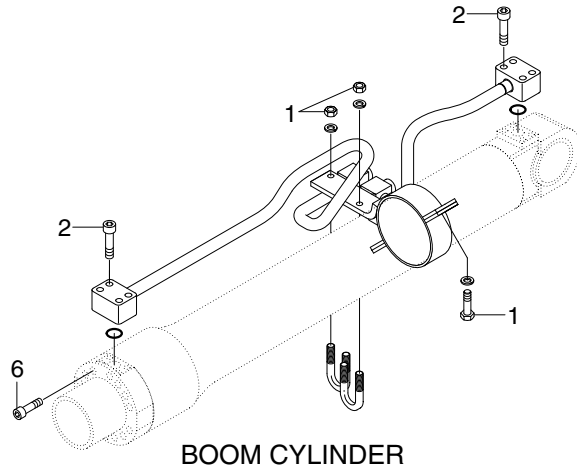
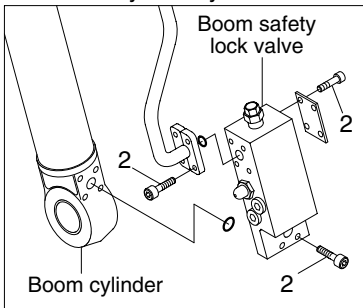

ARM CYLINDER

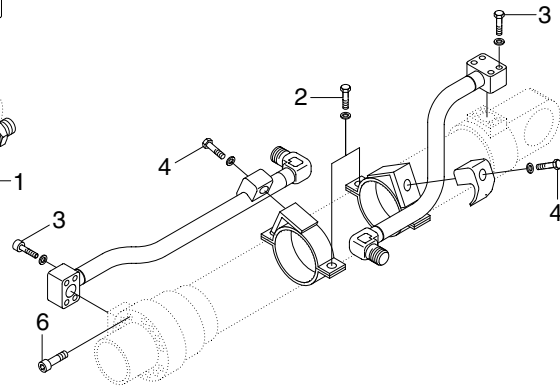

BUCKET CYLINDER

1607A9CM07

• Tightening torque

Item	Size	kgf · m	lbf · ft
1	M10×1.5	3.2±0.3	23.1±2.2
2	M10×1.5	5.4±0.5	39.1±3.6
3	M12×1.75	5.5±0.6	39.8±4.3

Item	Size	kgf · m	lbf · ft
4	M12×1.75	12.8±3.0	92.6±21.7
5	M16×2.0	23±2.0	166±14.5
6	M18×2.5	32±3.0	232±21.7