

GROUP 8 TURNING JOINT

1. REMOVAL AND INSTALL

1) REMOVAL

- (1) Lower the work equipment to the ground and stop the engine.
- (2) Operate the control levers and pedals several times to release the remaining pressure in the hydraulic piping.
- (3) Loosen the breather slowly to release the pressure inside the hydraulic tank.
- ▲ Escaping fluid under pressure can penetrate the skin causing serious injury. When pipes and hoses are disconnected, the oil inside the piping will flow out, so catch it in oil pan.
- (4) Disconnect all hoses.
- (5) Sling the turning joint assembly (1) and remove the mounting bolt(2).
 - Weight : 54kg(119lb)
 - Tightening torque : $12.3 \pm 1.3\text{kgf} \cdot \text{m}$
($88.9 \pm 9.4\text{bf} \cdot \text{ft}$)
- (6) Remove the turning joint assembly.
When removing the turning joint, check that all the hoses have been disconnected.

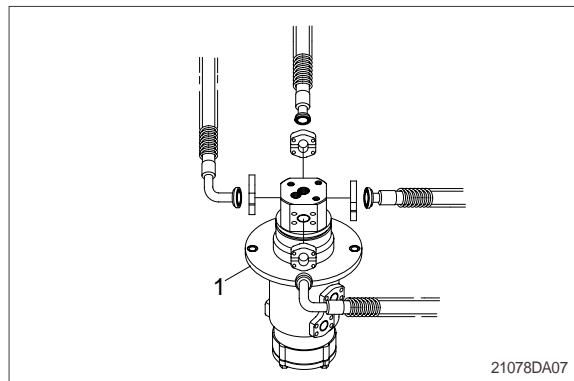

2) INSTALL

- (1) Carry out installation in the reverse order to removal.
Take care of turning joint direction.
Assemble hoses to their original positions.
Confirm the hydraulic oil level and check the hydraulic oil leak or not.

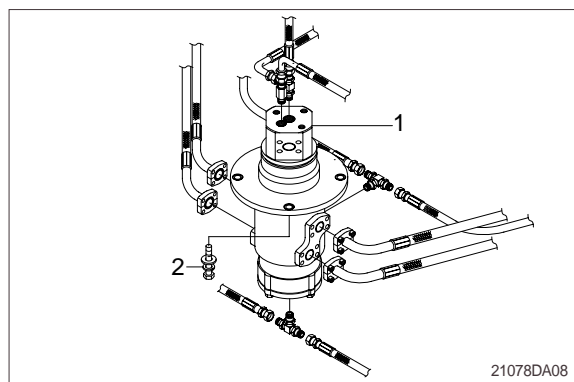

2. DISASSEMBLY AND ASSEMBLY

1) STRUCTURE

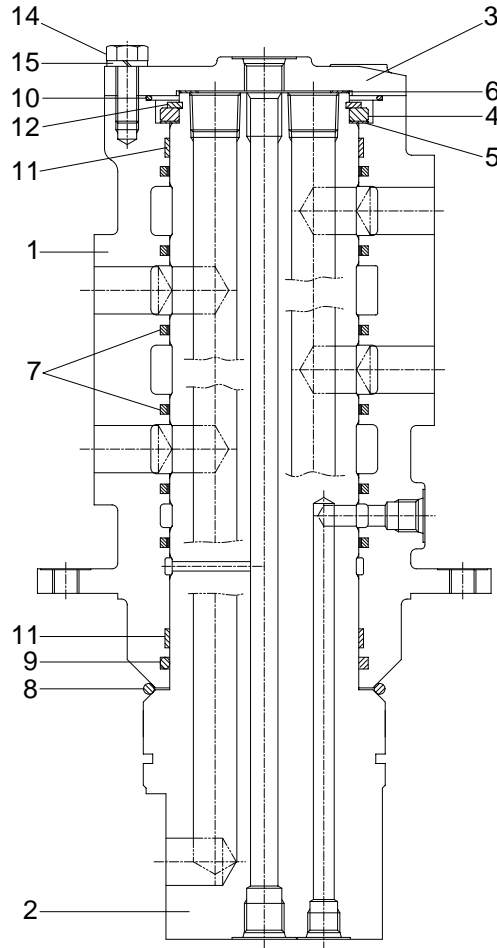

21078DA09

- | | | | | | |
|---|--------|----|--------------|----|---------------|
| 1 | Hub | 6 | Shim | 11 | Wear ring |
| 2 | Shaft | 7 | Slipper seal | 12 | Retainer ring |
| 3 | Cover | 8 | O-ring | 13 | Plug |
| 4 | Spacer | 9 | O-ring | 14 | Hexagon bolt |
| 5 | Shim | 10 | O-ring | 15 | Spring washer |

2) DISASSEMBLY

Before the disassembly, clean the turning joint.

- (1) Remove bolts(14), washer(15) and cover(3).

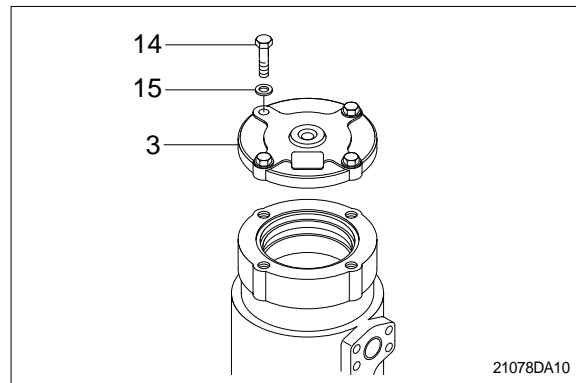

- (2) Remove shim(6) and O-ring(10).
- (3) Remove retainer ring(12), spacer(4) and shim(5).

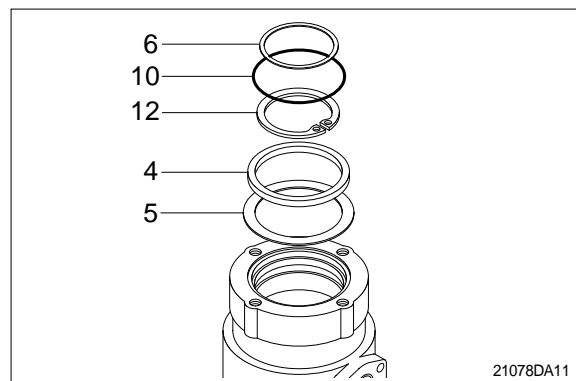

- (4) Place hub(1) on a V-block and by using a wood buffer at the shaft end, hit out shaft(2) to about 1/2 from the body with a hammer. Take care not to damage the shaft(2) when remove hub(1) or rest it sideways. Put a fitting mark on hub(1) and shaft(2).

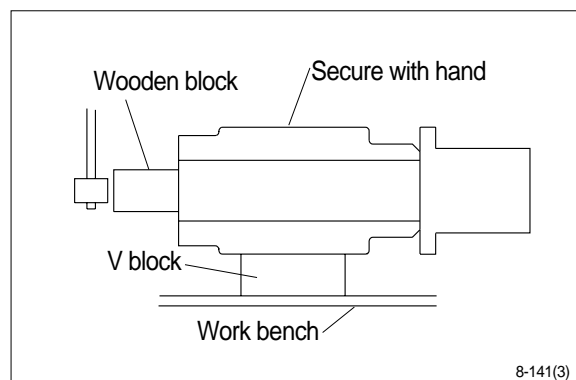

- (5) Remove six slipper seals(7) and O-ring(9), two ring wear(11) from hub(1).

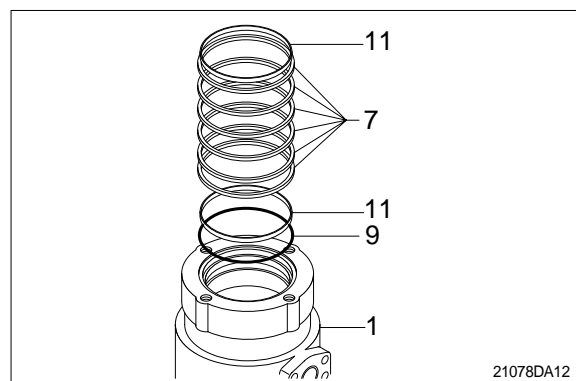

3) ASSEMBLY

Clean all parts.

As a general rule, replace oil seals and O-ring.

Coat the sliding surfaces of all parts with engine oil or grease before installing.

- (1) Fix seven slipper seal(7) and O-ring(9), two ring wear(11) to hub(1).
- (2) Fit O-ring(8) to shaft(2).

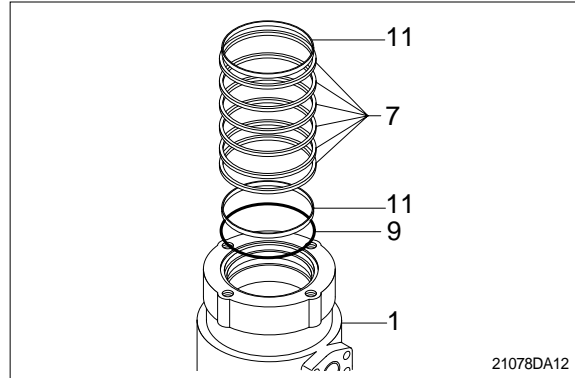

- (3) Set shaft(2) on block, tap hub(1) with a plastic hammer to install.

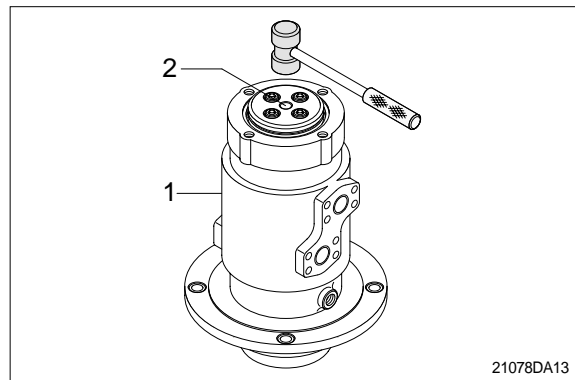

- (4) Fit shim(5), spacer(4) and retainer ring (12) to shaft(2).
- (5) Fit O-ring(10) to hub(1).
- (6) Fit shim(6) to shaft(2).

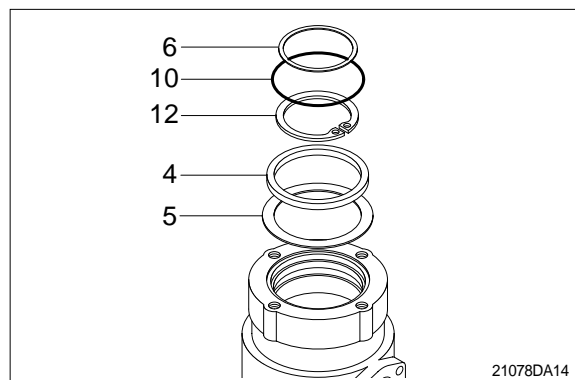

- (7) Install cover(3) to body(1) and tighten bolts(14).
· Torque : 10~12.5kgf · m(72.3~90.4lbf · ft)

