

GROUP 4 MECHATRONICS SYSTEM

1. ALL ACTUATORS SPEED ARE SLOW

Boom, Arm, Bucket, Swing and travel speed are slow, but engine speed is good.

Spec : M-mode 2200 ± 50rpm H-mode 2000 ± 50rpm S-mode 1900 ± 50rpm

Before carrying out below procedure, check all the related connectors are properly inserted.

1) INSPECTION PROCEDURE

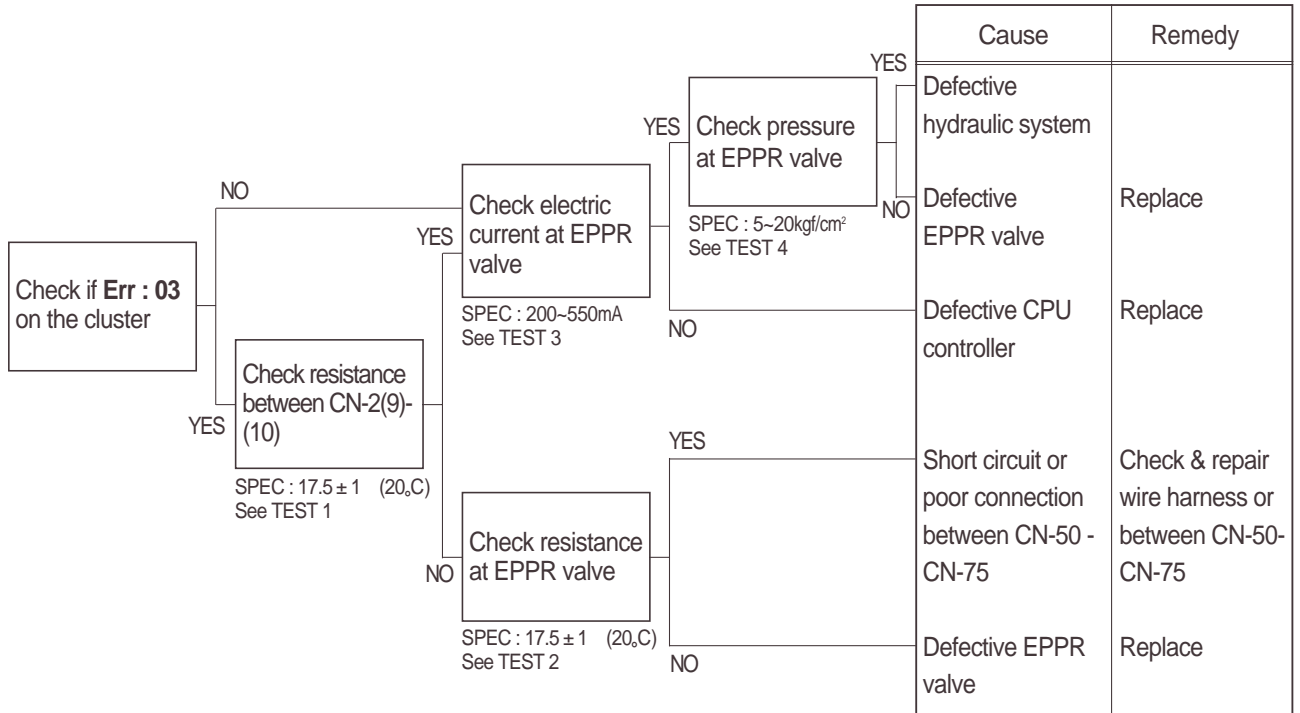

Wiring diagram

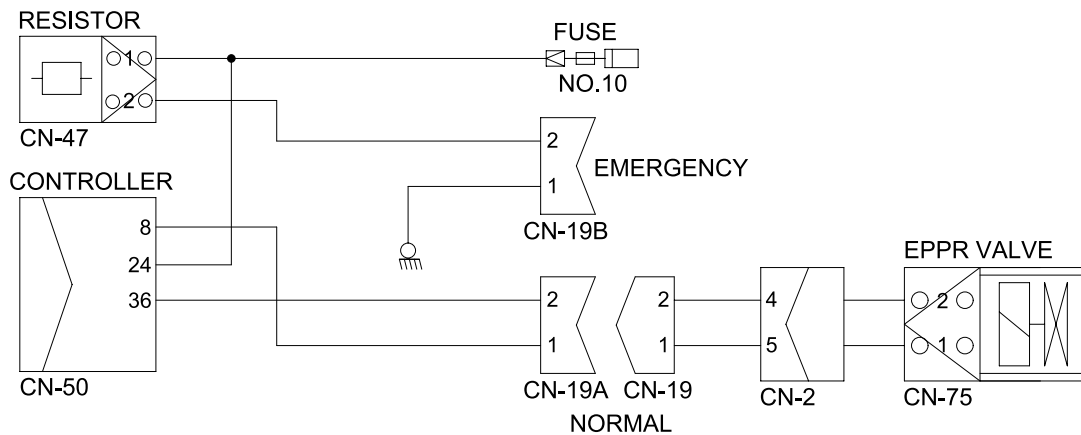

16075MS30

2) TEST PROCEDURE

- (1) **Test 1** : Check resistance at connector CN-2(9)-(10).

Starting key OFF.

Disconnect connector CN-2.

Check resistance between pin and at connector CN-2(9)-(10).

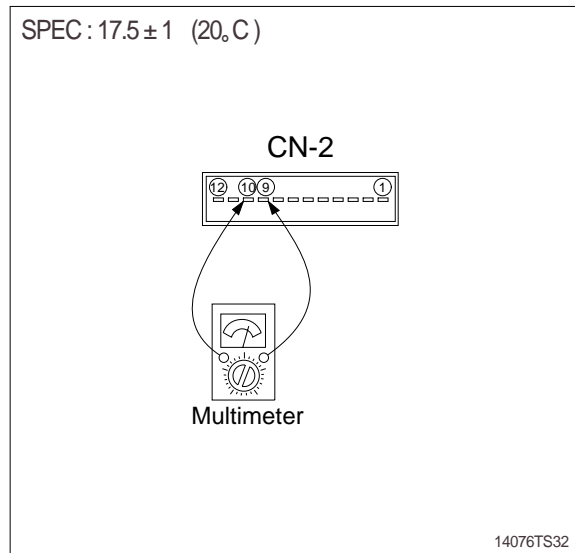

- (2) **Test 2** : Check resistance at connector CN-75.

Starting key OFF.

Disconnect connector CN-75 from EPPR valve at main hydraulic pump.

Check resistance between 2 lines as figure.

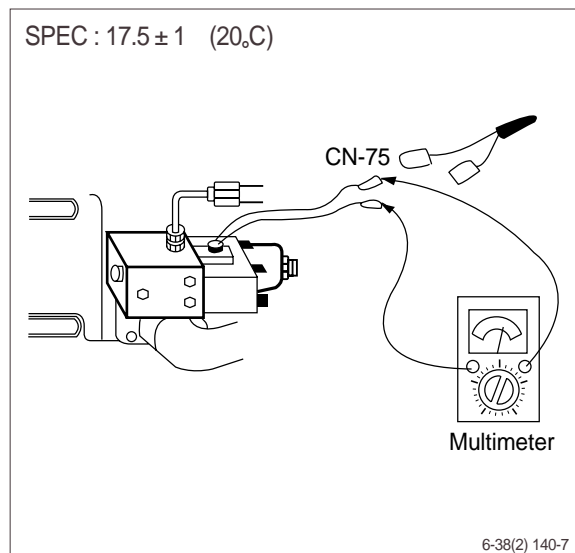

- (3) **Test 3** : Check electric current at EPPR valve.

Install multimeter as figure.

Start engine.

Set the accel dial at "10"(MAX)

Set S-mode and cancel auto decel mode.

If tachometer show approx 1900 ± 50 rpm, check electric current.

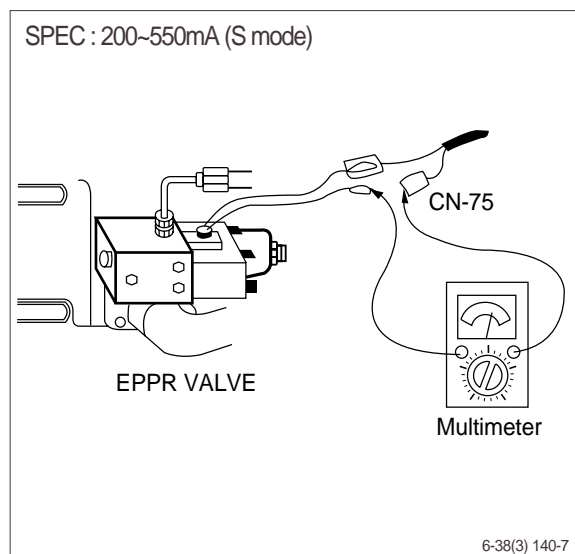

(2) **Test 4** : Check pressure at EPPR valve.
Remove plug and connect pressure gauge as figure.

- Gauge capacity : 0 to 40~50kgf/cm²
(0 to 570~710psi)

Start engine.

Set the accel dial at "10"(Max)

Set S-mode and cancel auto decel mode.

If tachometer show approx 1900±50rpm,
check pressure.

If pressure is not correct, adjust it.

After adjust, test the machine.

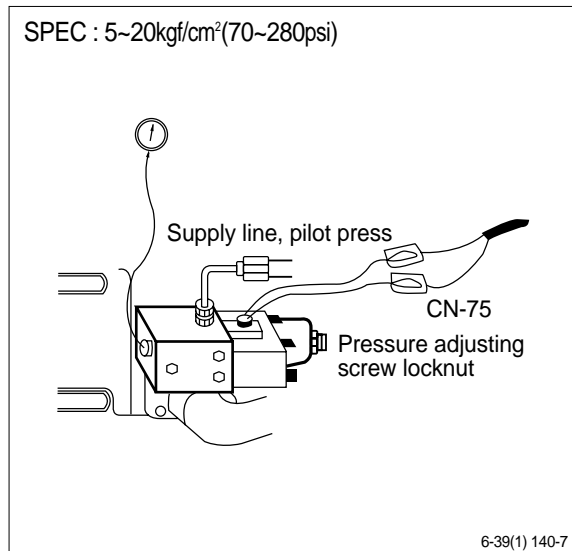

2) TEST PROCEDURE

- (1) **Test 5** : Check resistance between CN-50 (12)-(23).

Starting key OFF.

Disconnect connector CN-50 from CPU controller.

Check resistance as figure.

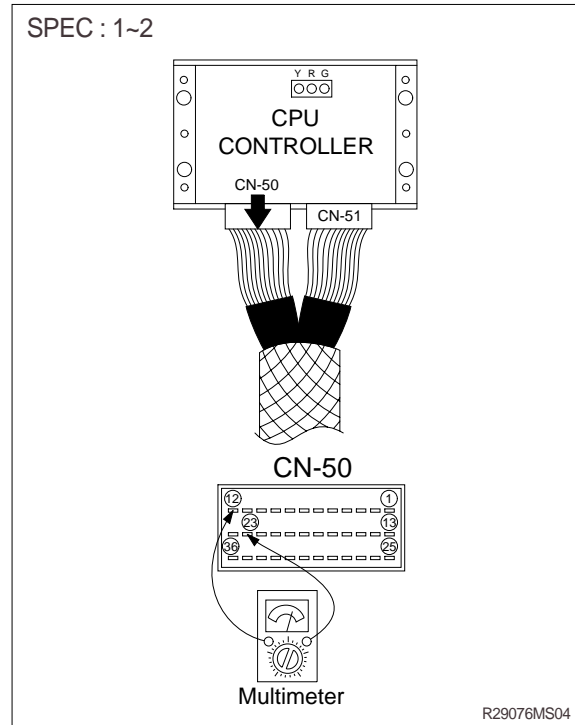

Unit : rpm

- (2) **Test 6** : Check tachometer(Work properly or not)

Start engine.

Check tachometer reading.

Spec		Remark
H-mode	2000 ± 50	Check rpm after cancel the Auto decel mode.
S-mode	1900 ± 50	

- (3) **Test 7** : Check resistance between CN-51 (25) and CN-51(26).

Starting key OFF.

Disconnect connector CN-51 from CPU controller.

Check resistance as figure.

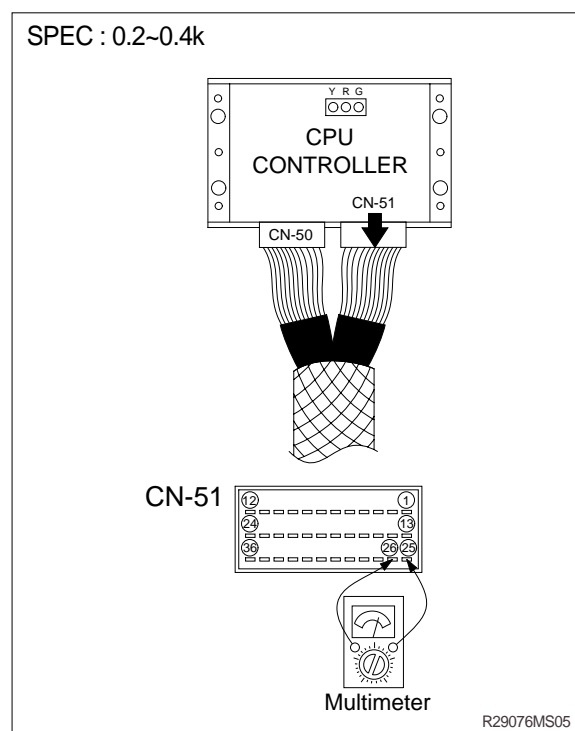

(4) **Test 8** : Check resistance at speed sensor.

Starting key OFF.

Disconnect connector CD-17 of speed sensor at engine flywheel housing.

Check resistance as figure.

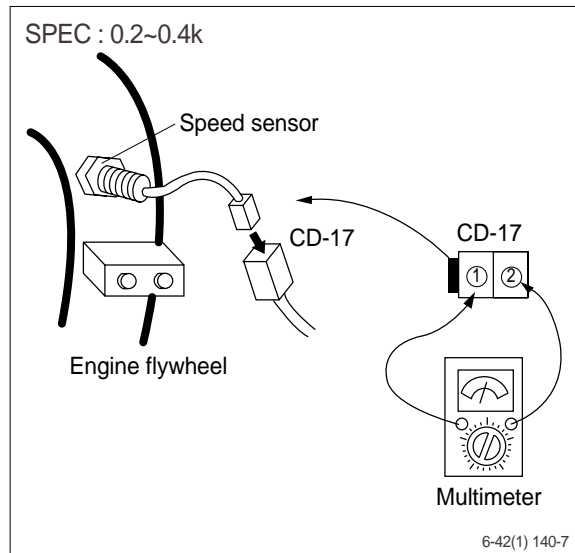

3. ENGINE STALL

Before carrying out below procedure, check all the related connectors are properly inserted.

1) INSPECTION PROCEDURE

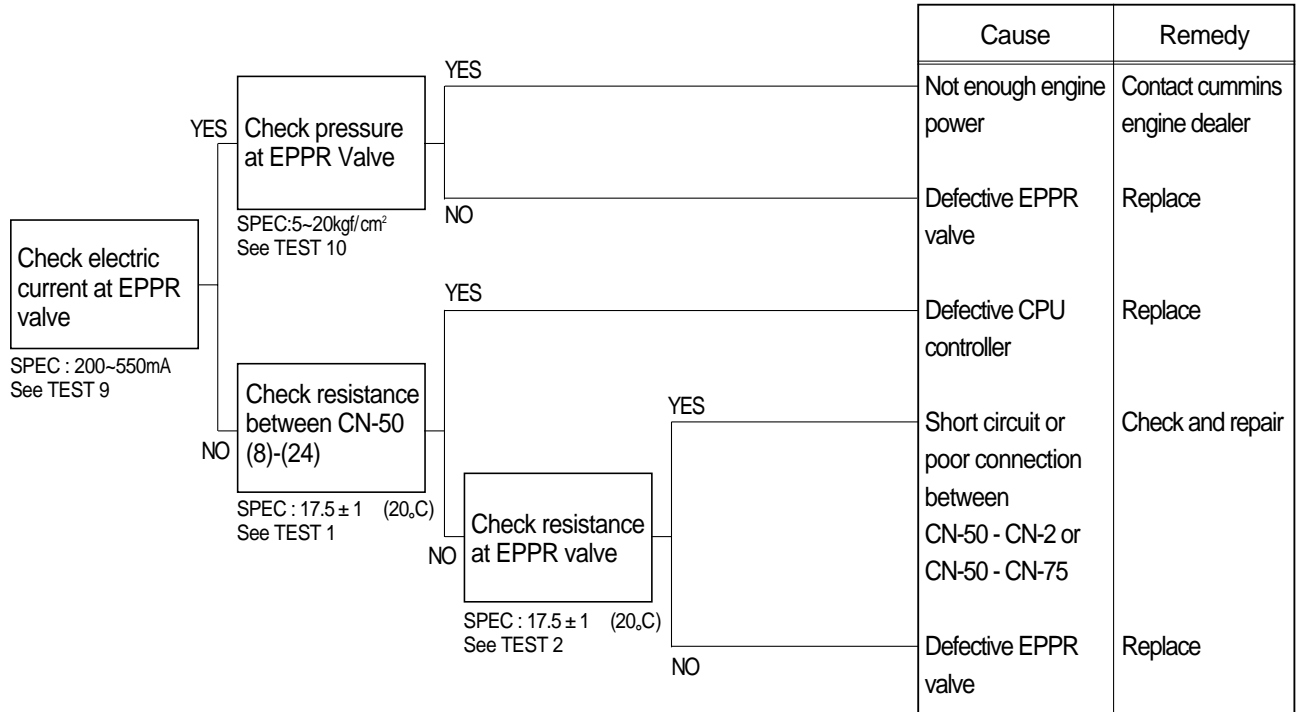

Wiring diagram

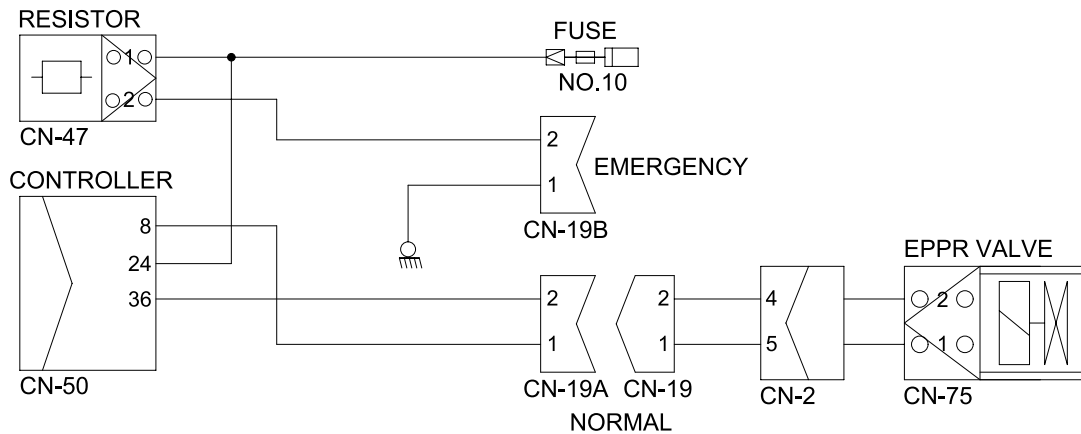

16075MS30

2) TEST PROCEDURE

- (1) **Test 9** : Check electric current at EPPR valve at S-mode
Install multimeter as figure.
Start engine.
Set the accel dial at "10"(max)
Set S-mode with 1900 ± 50 rpm.
Check electric current.

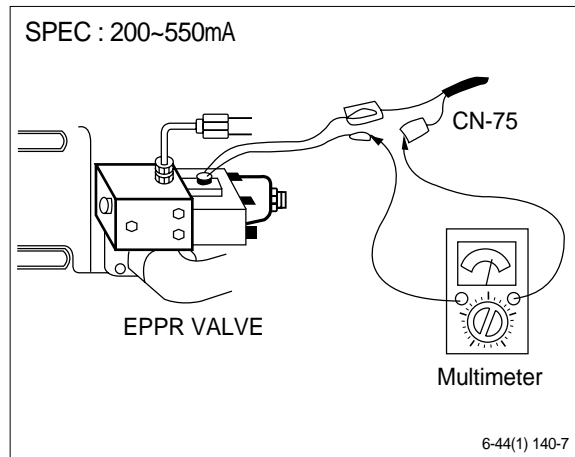

- (2) **Test 10** : Check pressure at EPPR valve at S-mode
Connect pressure gauge at EPPR valve.
Start engine.
Set the accel dial at "10"(max)
Set S-mode with 1900 ± 50 rpm.
Operate bucket lever completely push or pull.
Hold arm lever at the end of stroke.
Check pressure at relief position.

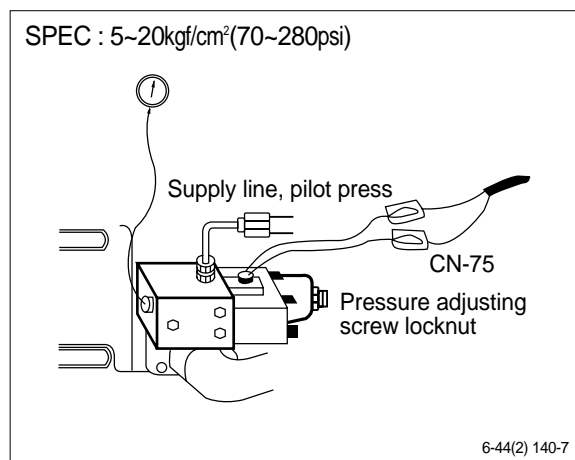

4. MALFUNCTION OF CLUSTER OR MODE SELECTION SYSTEM

Before carrying out below procedure, check all the related connectors are properly inserted.

1) INSPECTION PROCEDURE

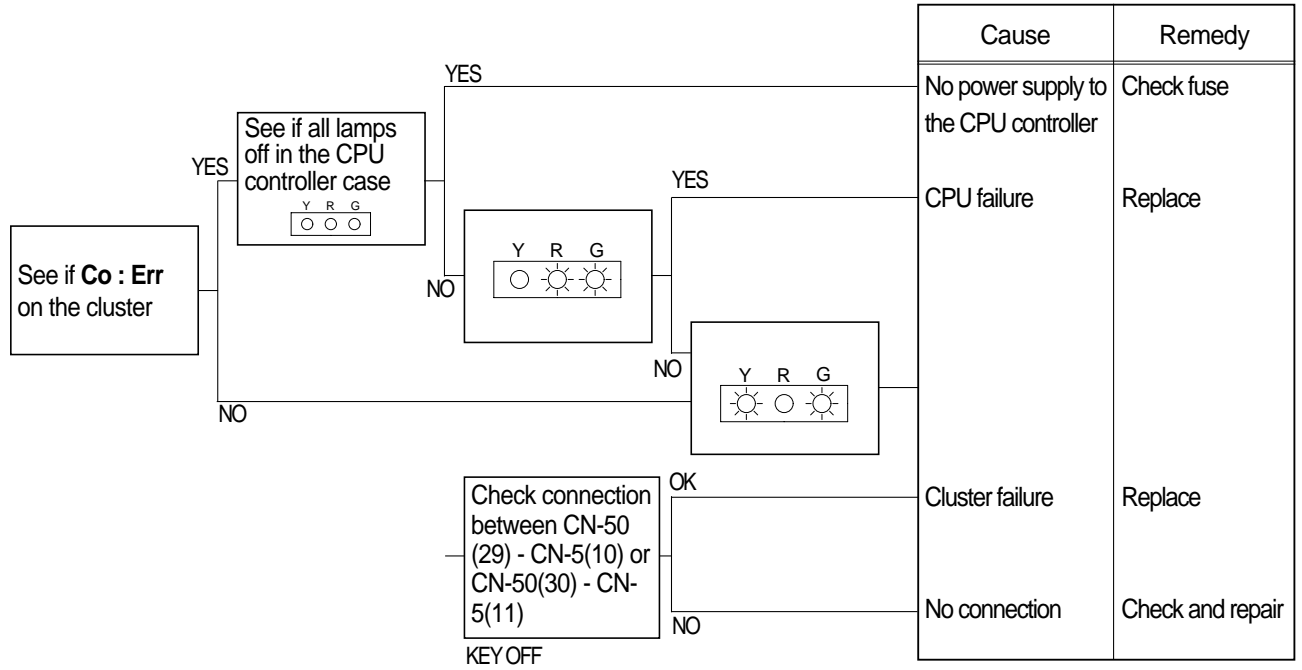

Wiring diagram

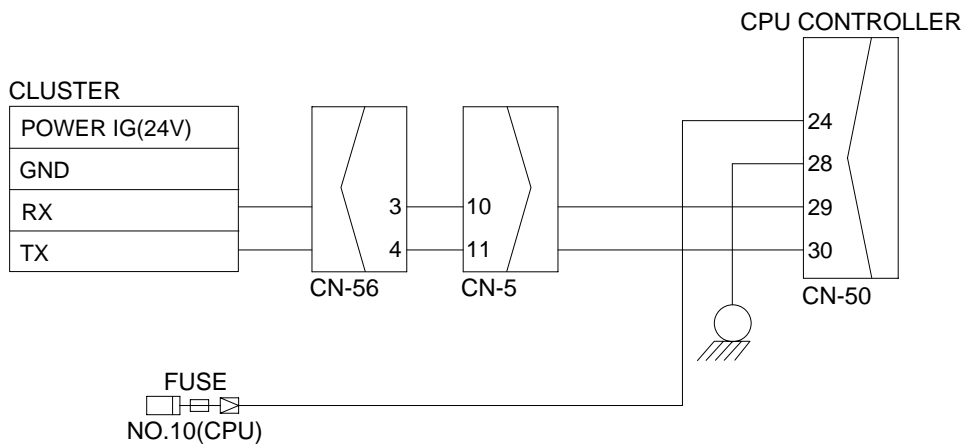

20W76MS03

5. SLOW ACTION OF ENGINE SPEED CHANGE WHEN CHANGE THE MODE

Before carrying out below procedure, check all the related connectors are properly inserted.

1) INSPECTION PROCEDURE

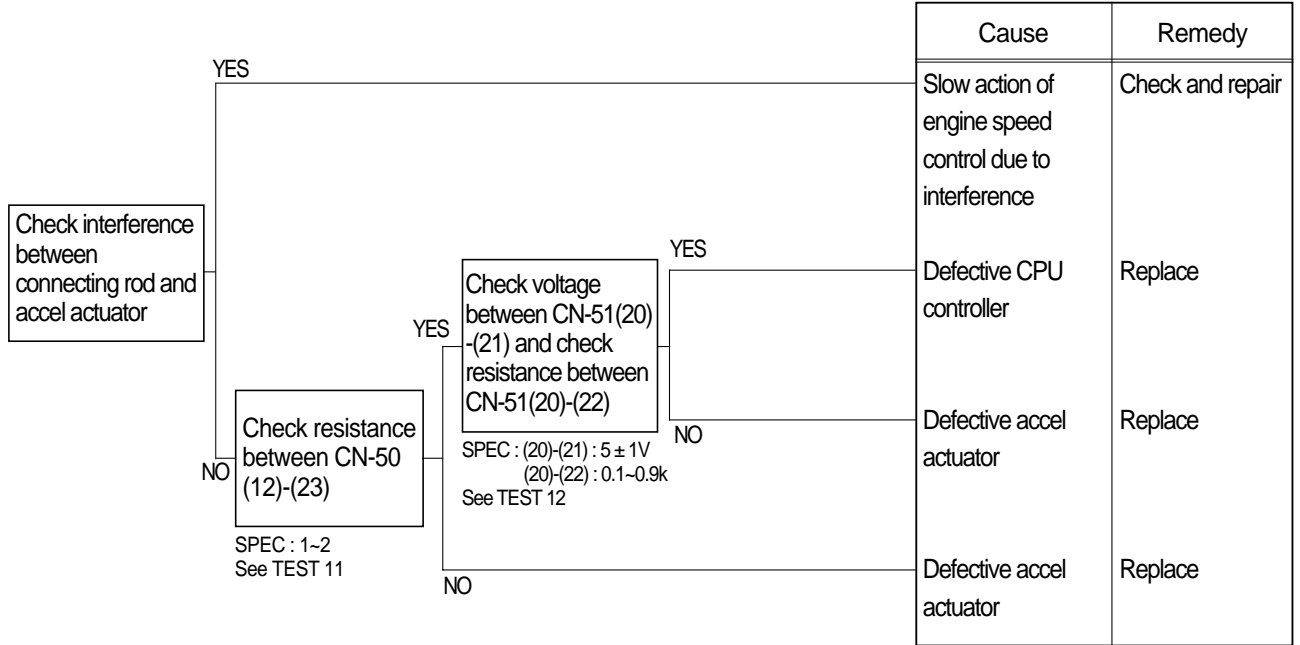

Wiring diagram

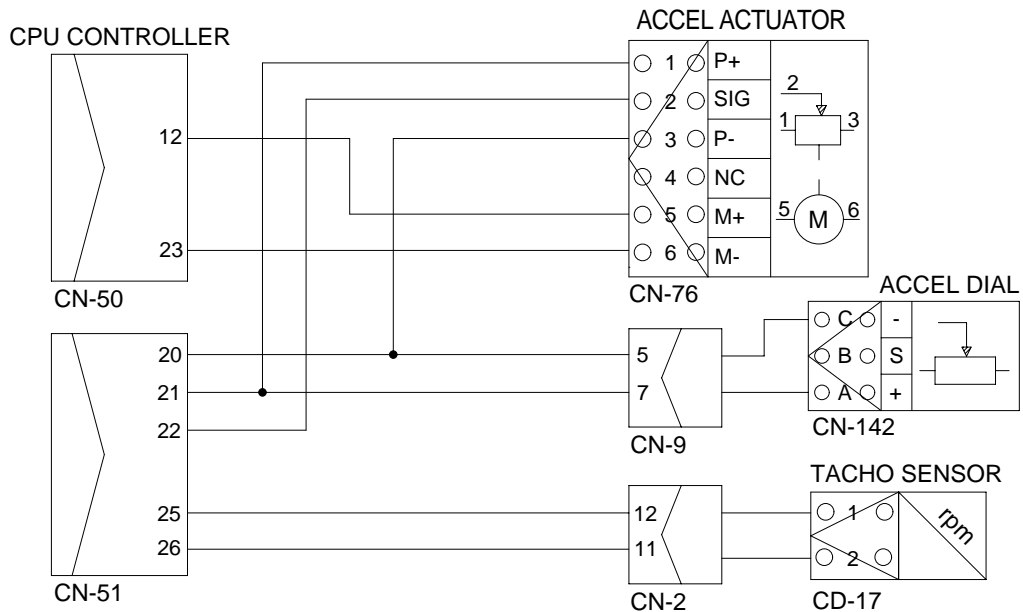

R29076MS03

2) TEST PROCEDURE

- (1) **Test 11** : Check resistance.
Starting key OFF.
Disconnect connector CN-50 from CPU controller.
Check resistance between CN-50(12)-(23) as figure.

SPEC : 1~2

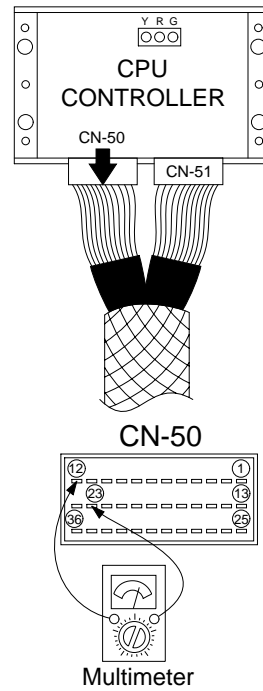

R29076MS04

- (2) **Test 12** : Check voltage and resistance.
 Check resistance between CN-51(20)-
 (22).
- Starting key OFF.
 - Disconnect connector CN-51 from CPU controller.
 - Check resistance value with multimeter as figure.

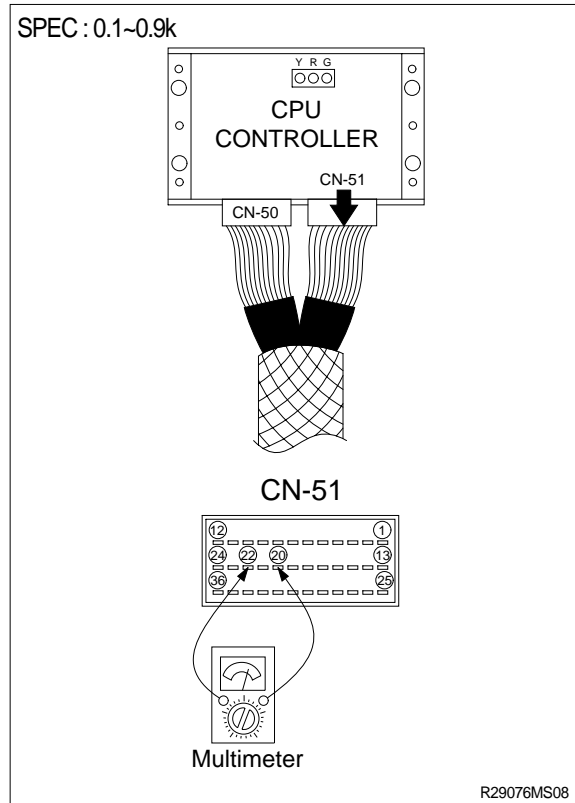

Check voltage between CN-51(20) and
 CN-51(21).

- Prepare 2 pieces of thin sharp pin, steel or copper.
- Starting key ON.
- Insert prepared pins to rear side of connectors : One pin to CN-51(20)
 Other pin to CN-51(21)
- Check voltage.

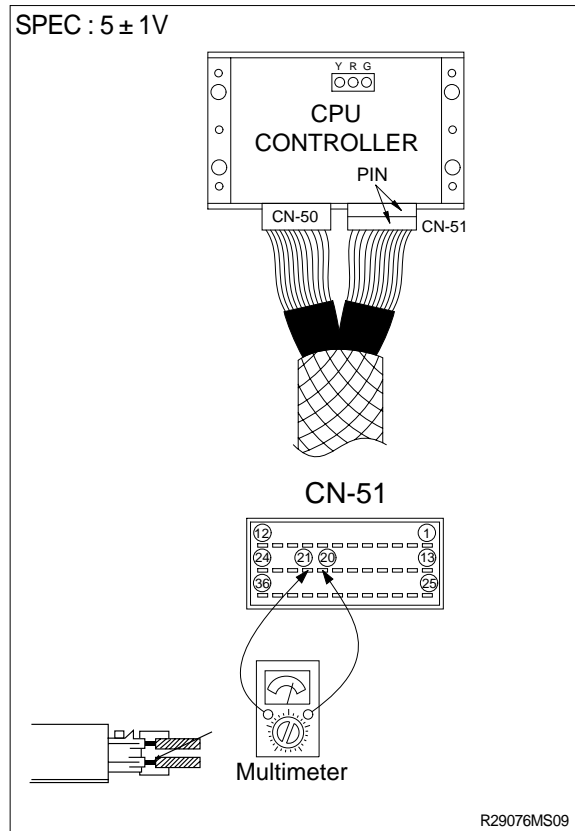

6. AUTO DECEL SYSTEM DOES NOT WORK

Before carrying out below procedure, check all the related connectors are properly inserted.

1) INSPECTION PROCEDURE

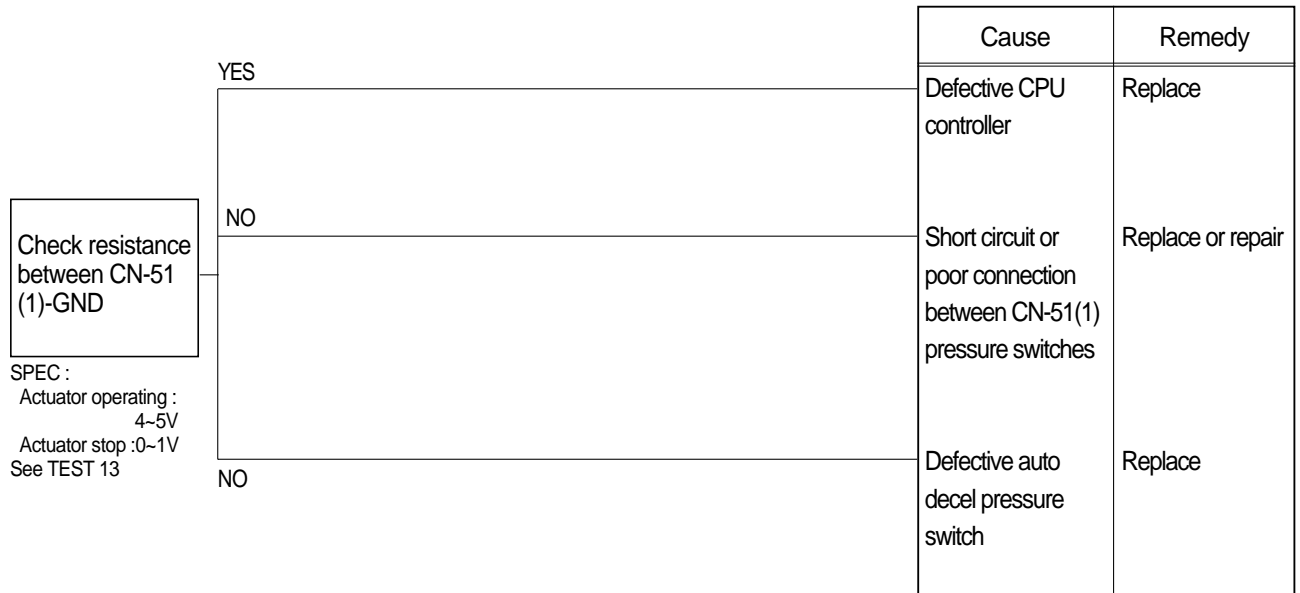

Wiring diagram



14076TS31

2) TEST PROCEDURE

(1) **Test 13** : Check voltage at CN-51(1) and ground.

Prepare 1 piece of thin sharp pin, steel or copper.

Starting key ON.

Insert prepared pin to rear side of connectors : One pin to (1) of CN-51.

Check voltage as figure.

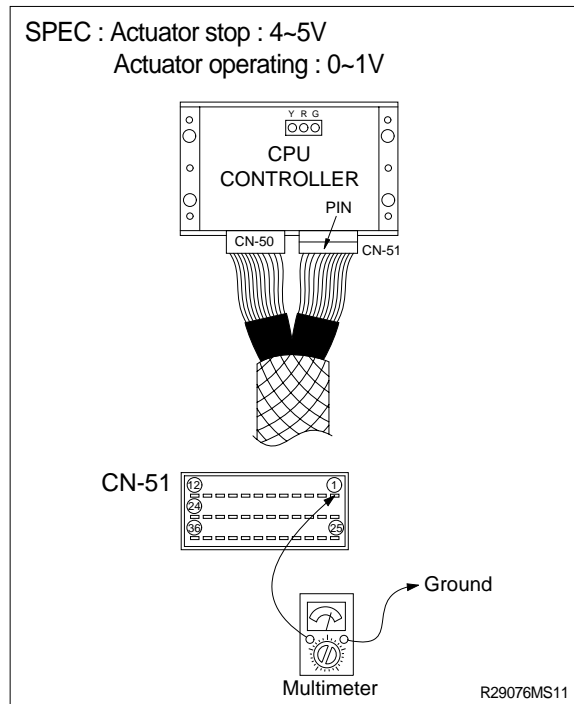

7. MALFUNCTION OF WARMING UP

Before carrying out below procedure, check all the related connectors are properly inserted.

1) INSPECTION PROCEDURE

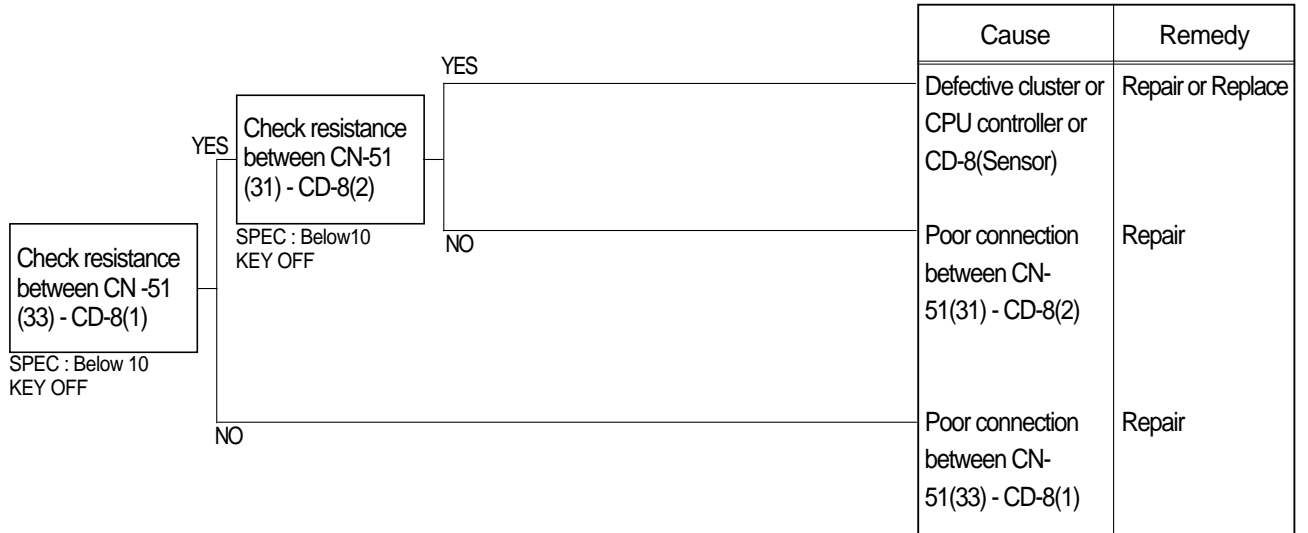

Wiring diagram

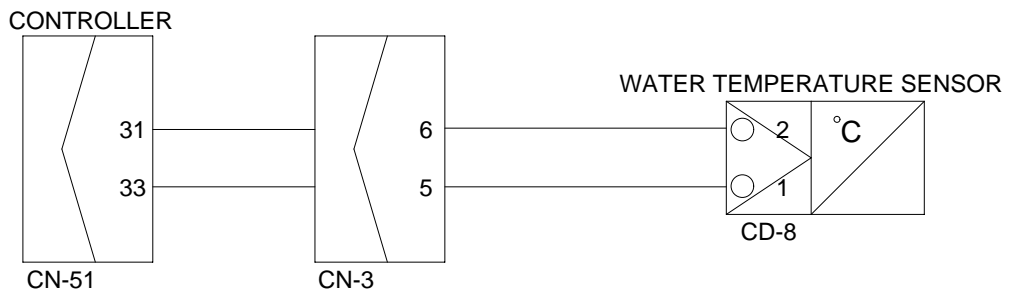

14076TS29

8. MALFUNCTION OF POWER MAX

Before carrying out below procedure, check all the related connectors are properly inserted.

1) INSPECTION PROCEDURE

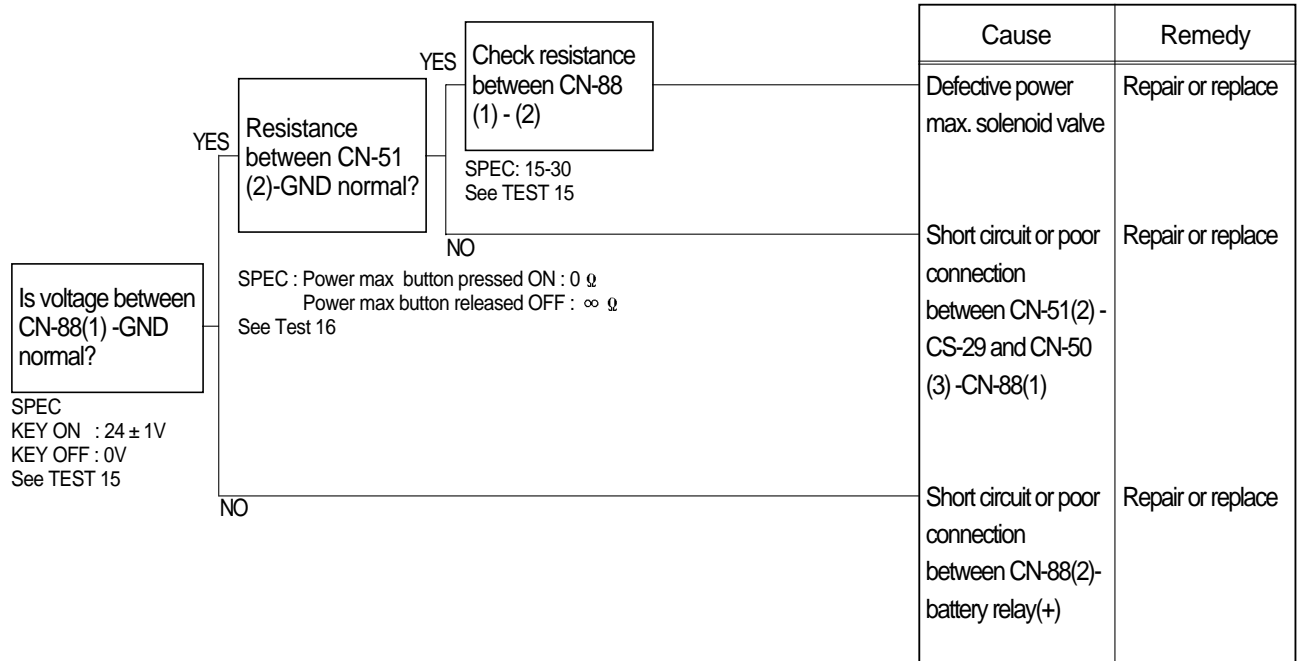

Wiring diagram

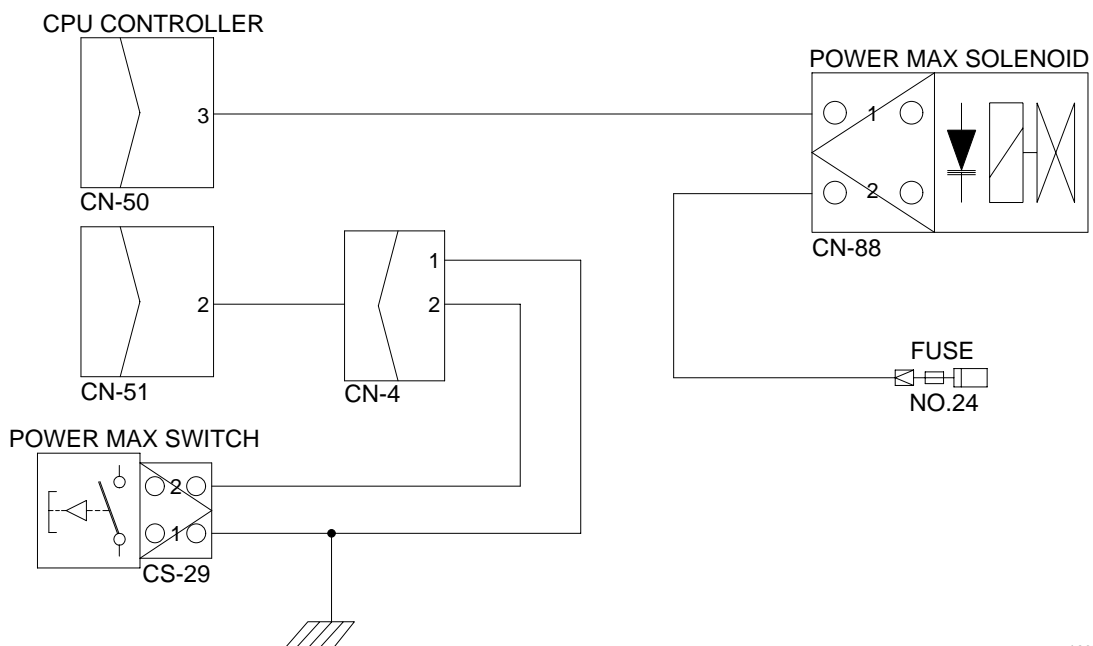

16076MS06

2) TEST PROCEDURE

- (1) **Test 15:** Check voltage between connector CN-88 - GND.

Start key ON.

Disconnect connector CN-88 from power max solenoid valve.

Check voltage as figure.

SPEC : Key ON : $24 \pm 1V$
Key OFF : 0V
Resistance : 15~30

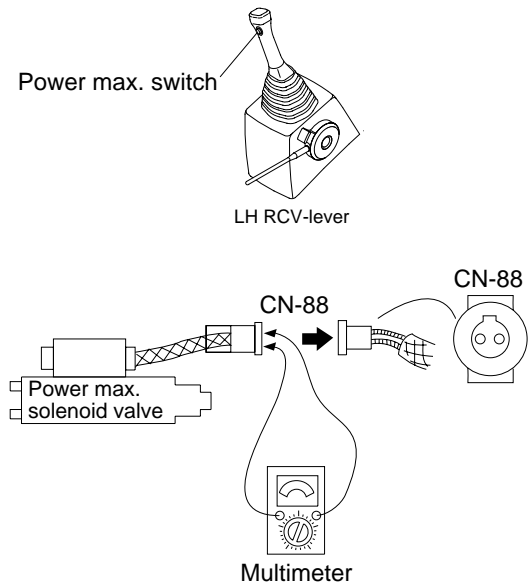

R29076MS14

- (2) **Test 16:** Check resistance between connector CN-51(2)-GND.

Starting key OFF.

Remove CPU controller and disconnect connector CN-51 from CPU controller.

Check resistance as figure.

SPEC : Power max button pressed ON : 0
Power max button released OFF :

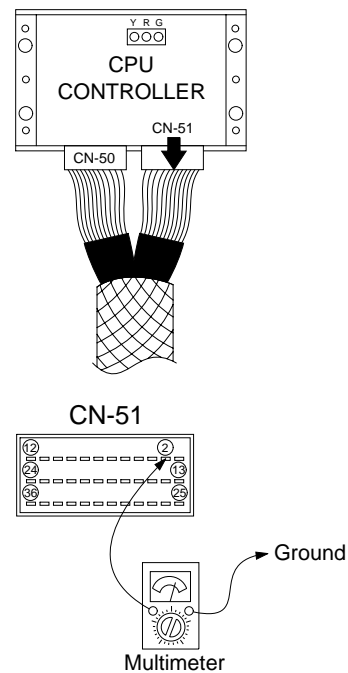

R29076MS15