

GROUP 2 ELECTRICAL CIRCUIT

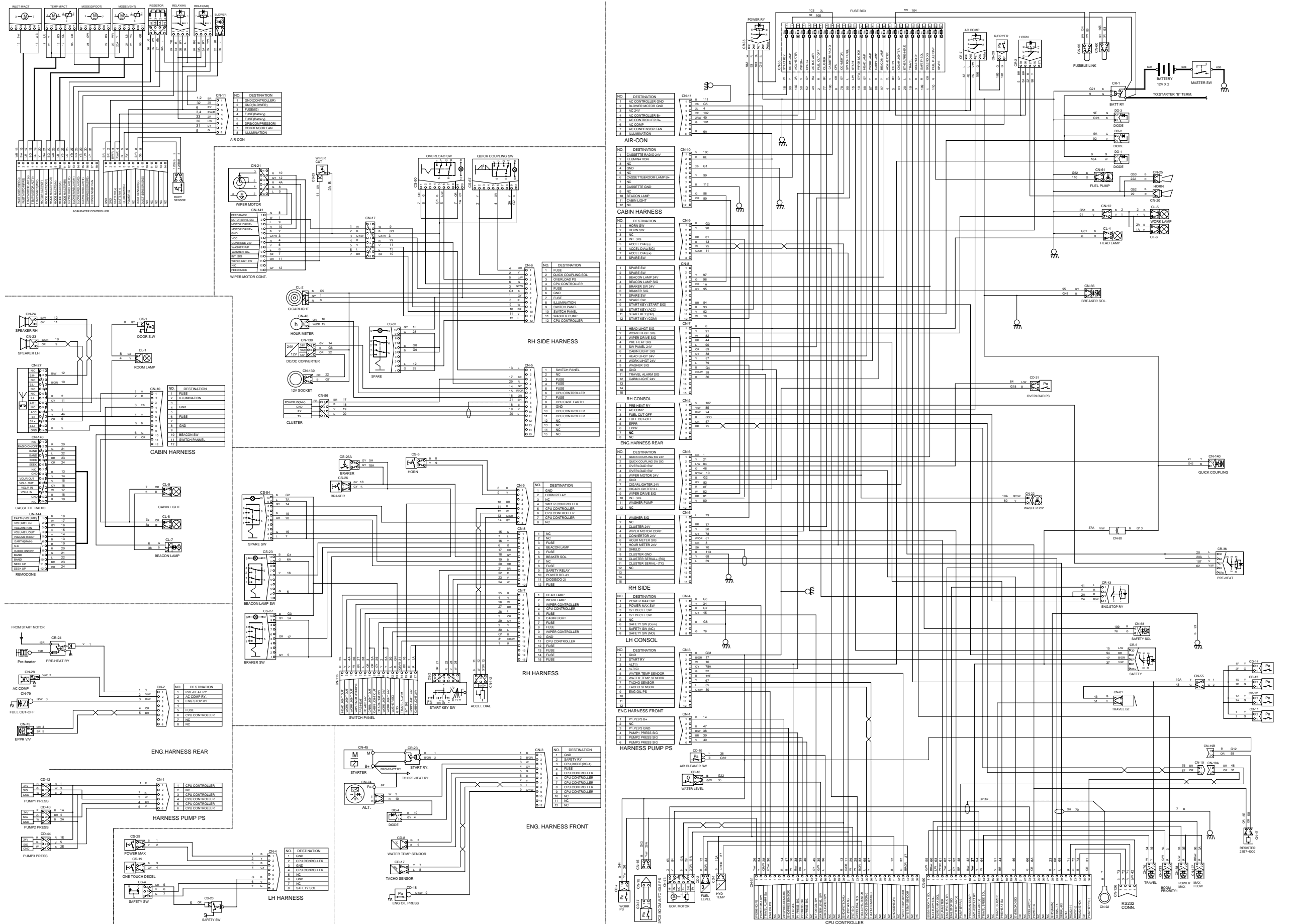

MEMORANDUM



1. POWER CIRCUIT

The negative terminal of battery is grounded to the machine chassis.

When the start switch is in the OFF position, the current flows from the positive battery terminal as shown below.

1) OPERATING FLOW

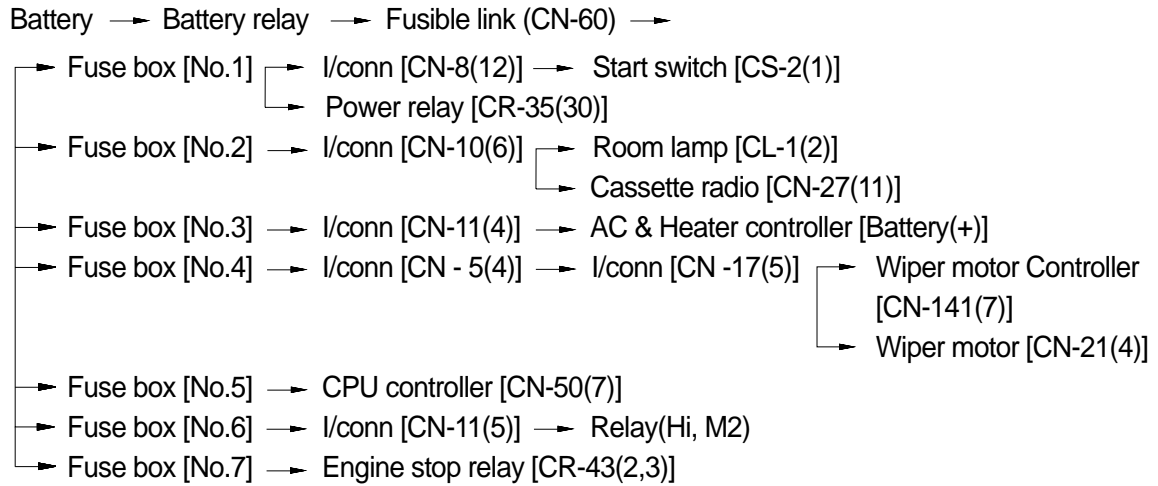

I/conn : Intermediate connector

2) CHECK POINT

Engine	Start switch	Check point	Voltage
OFF	OFF	① - GND (Battery 2 EA) ② - GND (Battery 2 EA) ③ - GND (Fusible link)	20~25V 20~25V 20~25V

GND : Ground

POWER CIRCUIT

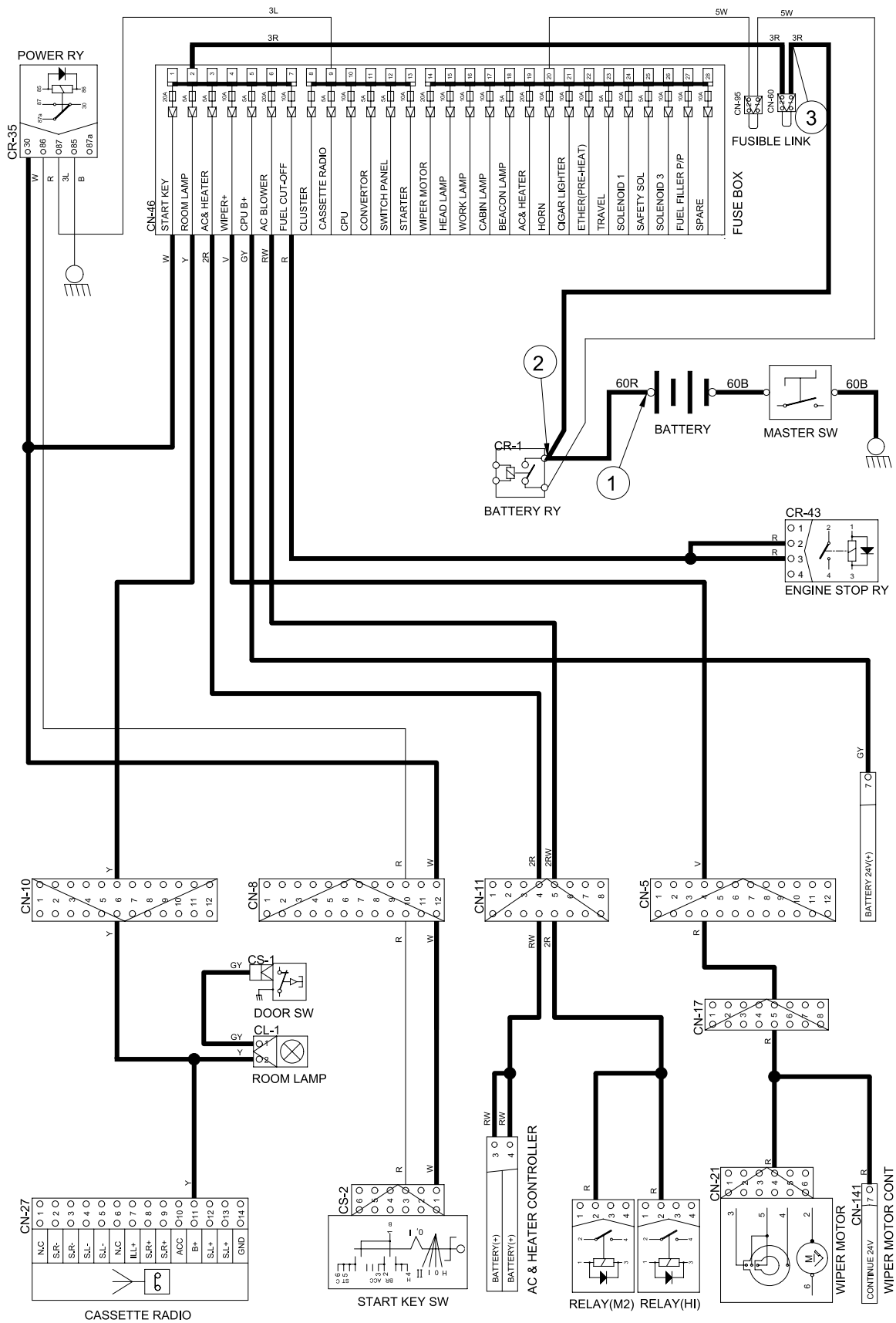

16074EL04

2. STARTING CIRCUIT

1) OPERATING FLOW

Battery(+) terminal → Battery relay[CR-1] → Fusible link → Fuse box No.1
 → I/conn [CN-8(12)] → Start key [CS-2(1)]

Start switch : ON

→ Start switch ON [CS-2(2)] → I/conn [CN-8(11)] → Diode[DO-2] →
 Battery relay [CR-1]:Battery relay operating(All power is supplied with the electric component)
 → Start switch ON [CS-2(3)] → I/conn [CN-8(10)] → Power relay [CR-35(86) (87)]
 → Fuse box (All power is supplied with electric component)

Start switch : START

Start switch START[CS-2(5)] → I/conn[CN-8(9)] → Safety relay [CR-5(86) (87)]
 → I/conn [CN-3(2)] → Start relay [CR-23]

2) CHECK POINT

Engine	Start switch	Check point	Voltage
Operating	Start	<ul style="list-style-type: none"> - GND (Battery) - GND (Start key) - GND (Battery relay M4) - GND (Starter B +) - GND (Starter M) - GND (Start relay) - GND (Battery relay M8) 	20 ~ 25V

GND : Ground

STARTING CIRCUIT

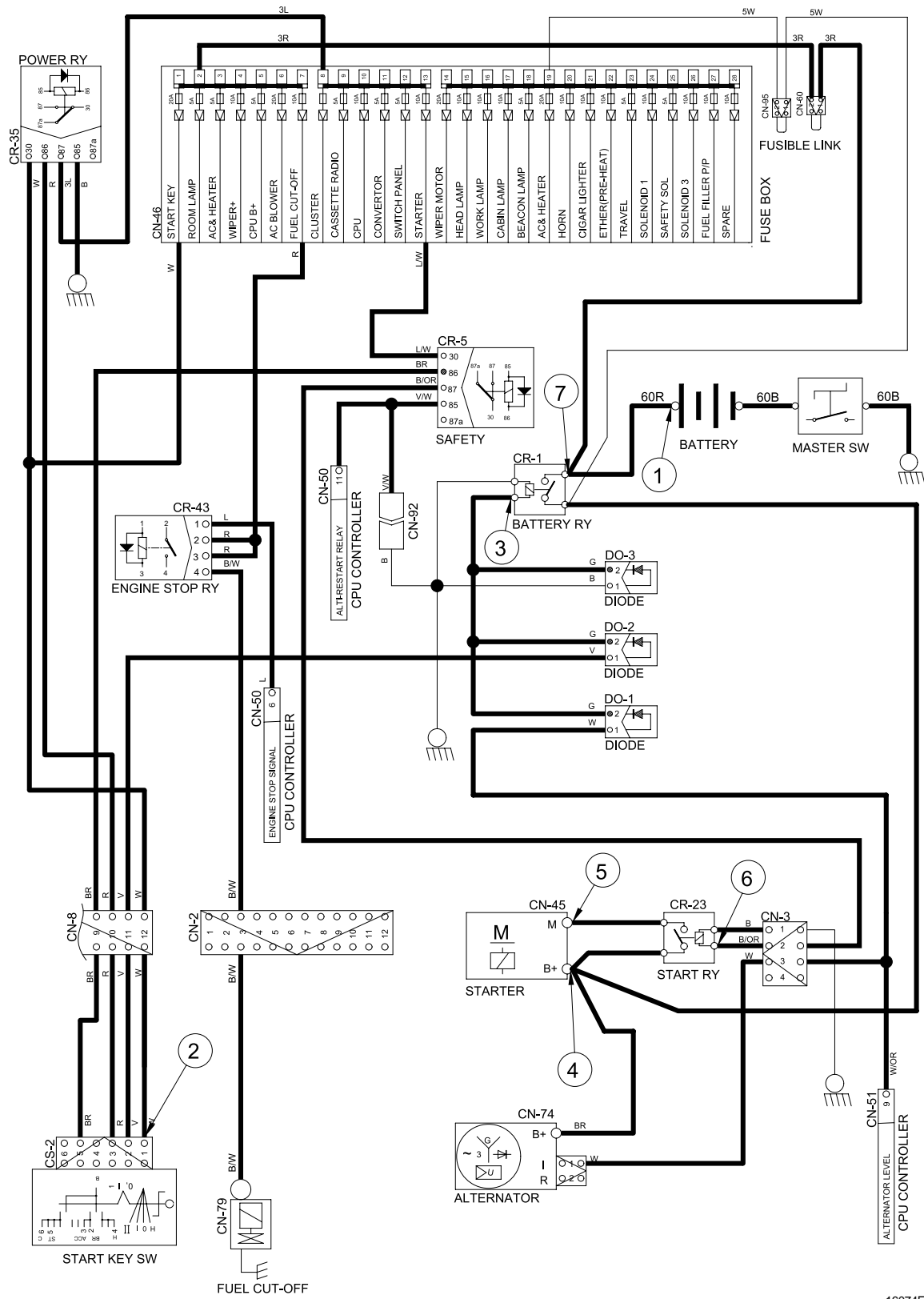

16074EL05

3. CHARGING CIRCUIT

When the starter is activated and the engine is started, the operator releases the key switch to the ON position.

Charging current generated by operating alternator flows into the battery through the Battery relay(CR-1).

The current also flows from alternator to each electrical component and controller through the fuse box.

1) OPERATING FLOW

(1) Warning flow

Alternator " I " terminal → I/conn [CN-3(3)] → CPU Controller [CN-51(9)] → Cluster warning lamp (Via serial interface)

(2) Charging flow

Alternator "B+" terminal → Battery relay → Battery(+) terminal
 → Fusible link [CN-60] → Fuse box

2) CHECK POINT

Engine	Start switch	Check point	Voltage
ON	ON	- GND (Battery voltage) - GND (Battery relay) - GND (Alternator B terminal) - GND (Alternator I terminal) - GND (CPU)	20~27V

GND : Ground

CHARGING CIRCUIT

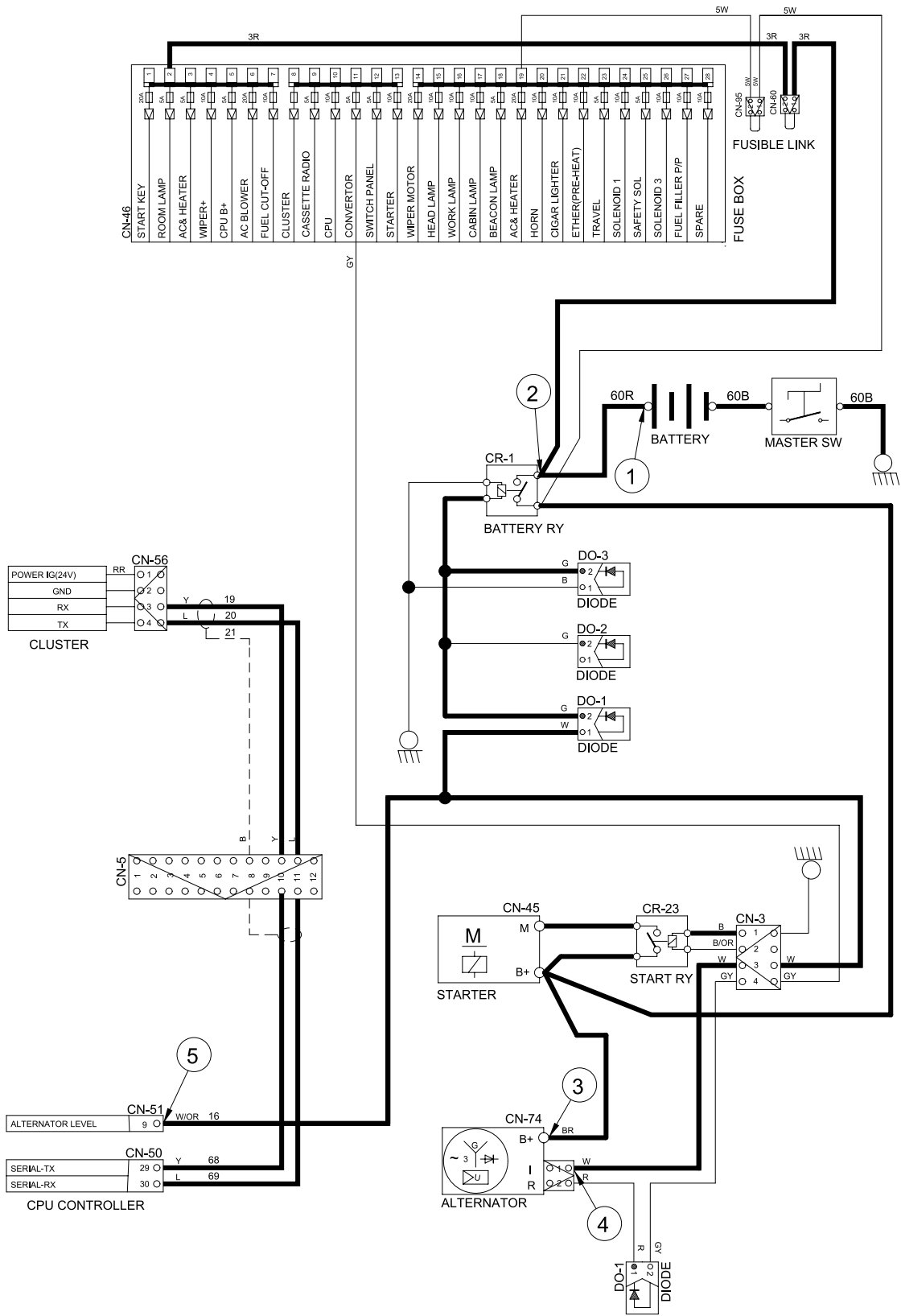

16074EL06

4. HEAD AND WORK LIGHT CIRCUIT

1) OPERATING FLOW

Fuse box (No.15) → I/conn [CN-7(7)] → Switch panel [CN-116(9)]

Fuse box (No.16) → I/conn [CN-7(8)] → Switch panel [CN-116(10,11)]

(1) Main light switch ON

Head light switch ON [CN-116(1)] → I/conn [CN-7(1)]

→ Head light ON [CL-4(2)]

→ I/conn [CN-10(2)] → Cassette radio illumination ON [CN-27(7)]

→ I/conn [CN-11(8)] → AC & Heater controller illumination ON

→ I/conn [CN-6(8)] → Cigarlight [CL-2]

(2) Main light switch ON

Work light switch ON [CN-116(2,3)] → I/conn [CN-7(2)] → I/conn [CN-12(1)]

→ Work light ON [CL-5(2), CL-6(2)]

2) CHECK POINT

Engine	Start switch	Check point	Voltage
STOP	ON	- GND(Fuse box) - GND(Switch power input) - GND(Switch power output) - GND(Head light)	20~25V
STOP	ON	- GND(Fuse box) - GND(Switch power input) - GND(Switch power output) - GND(Work light)	20~25V

GND : Ground

HEAD AND WORK LAMP CIRCUIT

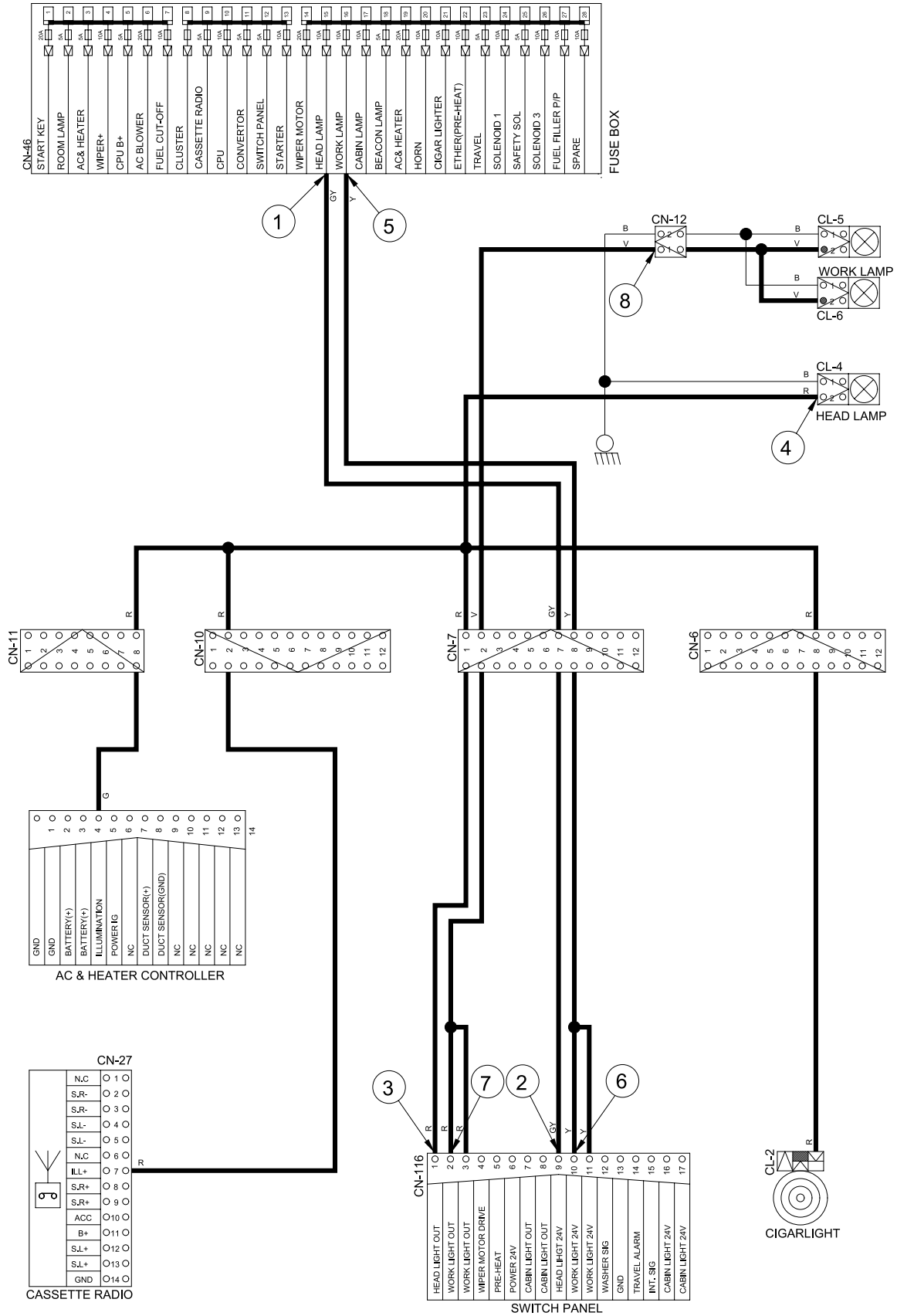

16074EL07

5. BEACON LAMP AND CAB LIGHT CIRCUIT

1) OPERATING FLOW

Fuse box (No.18) → I/conn [CN-8(3)] → Beacon lamp switch [CN-23(6)]

Fuse box (No.17) → I/conn [CN-7(12)] → Switch panel [CN-116(16, 17)]

(1) Beacon lamp switch ON

Beacon lamp switch ON [CS-23(2)] → Switch Indicator lamp ON [CS-23(9)]
 → I/conn [CN-8(4)] → I/conn [CN-10(10)]
 → Beacon lamp ON [CL-7]

(2) Cab light switch ON

Cab light switch ON [CN-116(7, 8)] → I/conn [CN-7(6)] → I/conn [CN-10(11)]
 → Cab light ON [CL-8(2), CL-9(2)]

2) CHECK POINT

Engine	Start switch	Check point	Voltage
STOP	ON	- GND(Fuse box) - GND(Switch power input) - GND(Switch power output) - GND(Beacon lamp)	20~25V
STOP	ON	- GND(Fuse box) - GND(Switch power input) - GND(Switch power output) - GND(Cab light)	20~25V

GND : Ground

BEACON LAMP AND CAB LAMP CIRCUIT

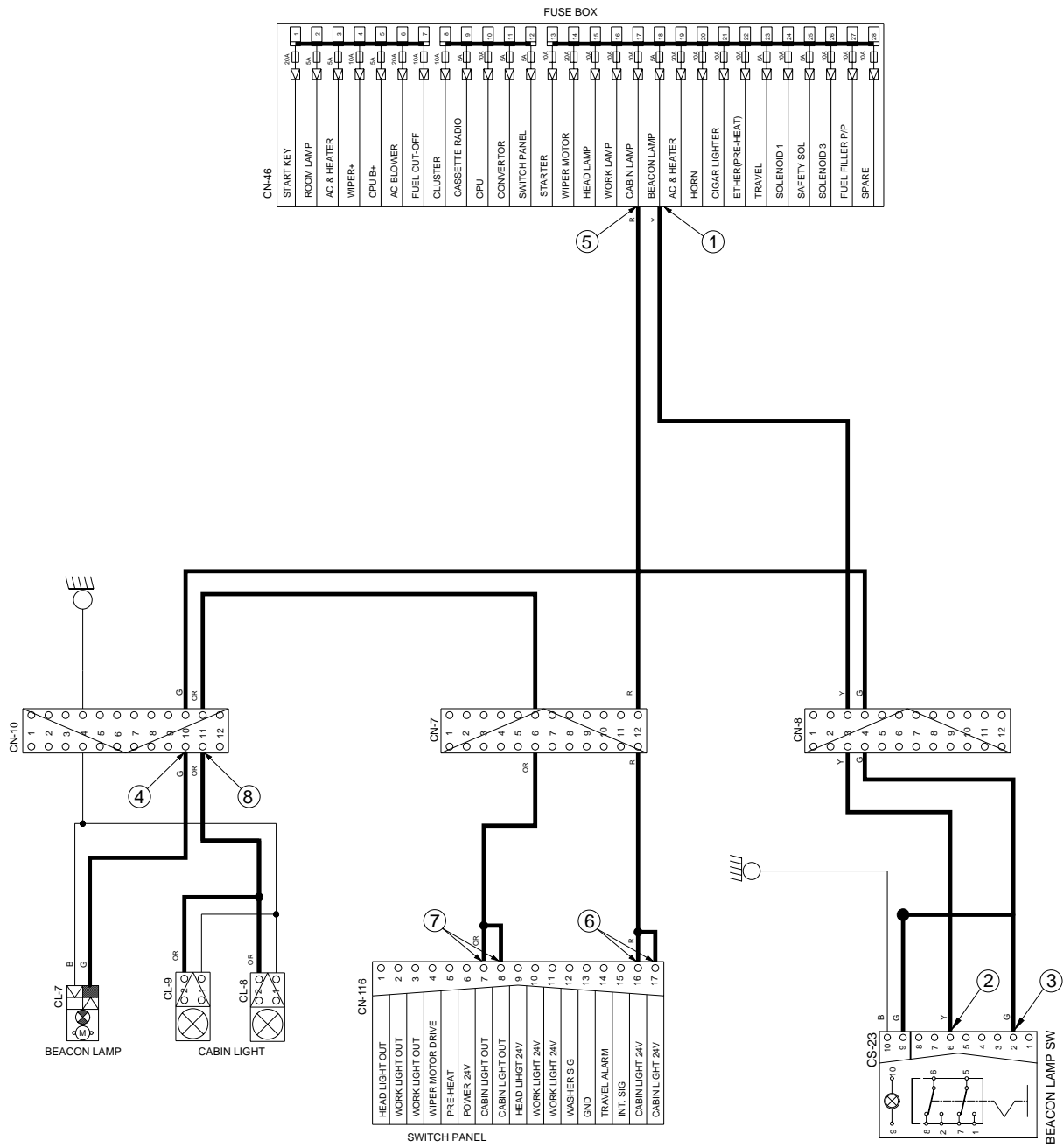

16074EL09

6. WIPER AND WASHER CIRCUIT

1) OPERATING FLOW

(1) Key switch ON

Fuse box (No.12) → I/conn [CN-7(5)] → Switch panel [CN-116(6)]

Fuse box (No.4) → I/conn [CN-5(4)] → I/conn [CN-17(5)] → Wiper motor controller [CN-141(7)]
 → Wiper motor [CN-21(4)]

Fuse box (No.14) → I/conn [CN-6(5)] → I/conn [CN-17(4)] → Wiper motor controller [CN-141(6)]
 → Washer pump [CN-22(2)]

(2) Wipe switch ON : 1st step(Intermittent)

Wiper switch ON [CN-116(15)] → I/conn[CN-9(4)] → I/conn[CN-6(10)] → I/conn[CN-17(8)] →
 Wiper motor controller [CN-141(10) (3)] → Wiper motor intermittently operating [CN-21(6)]

(3) Wiper switch ON : 2nd step(Low speed)

Wiper switch ON [CN-116(4)] → I/conn [CN-7(3)] → I/conn [CN-6(9)] → I/conn[CN-17(2)] →
 Wiper motor controller [CN-141(2) (4)] → Wiper motor operating [CN-21(2)]

(4) Washer switch ON

Washer switch ON [CN-116(12)] → I/conn [CN-7(9)] → I/conn [CN-5(1)] → I/conn [CN-17(7)]
 → Wiper motor controller [CN-141(9) (8)] → I/conn [CN-17(6)] → I/conn [CN-6(11)]
 → Washer operating [CN-22(1)]

Wiper switch ON [CN-116(4)] → I/conn [CN-7(3)] → I/conn [CN-6(9)] → I/conn[CN-17(2)] →
 Wiper motor controller [CN-141(2) (4)] → Wiper motor operating [CN-21(2)]

(5) Auto parking(When switch OFF)

Switch OFF [CN-116(4)] → Wiper motor parking position by wiper motor controller

2) CHECK POINT

Engine	Start switch	Check point	Voltage
STOP	ON	- GND(Fuse box)	24V
		- GND(Switch power input)	
		- GND(Switch power output)	0~5V
		- GND(Wiper Power input)	
		- GND(Wiper power output)	
		- GND(Wiper motor)	0 or 24V

GND : Ground

WASHER CONTROL CIRCUIT

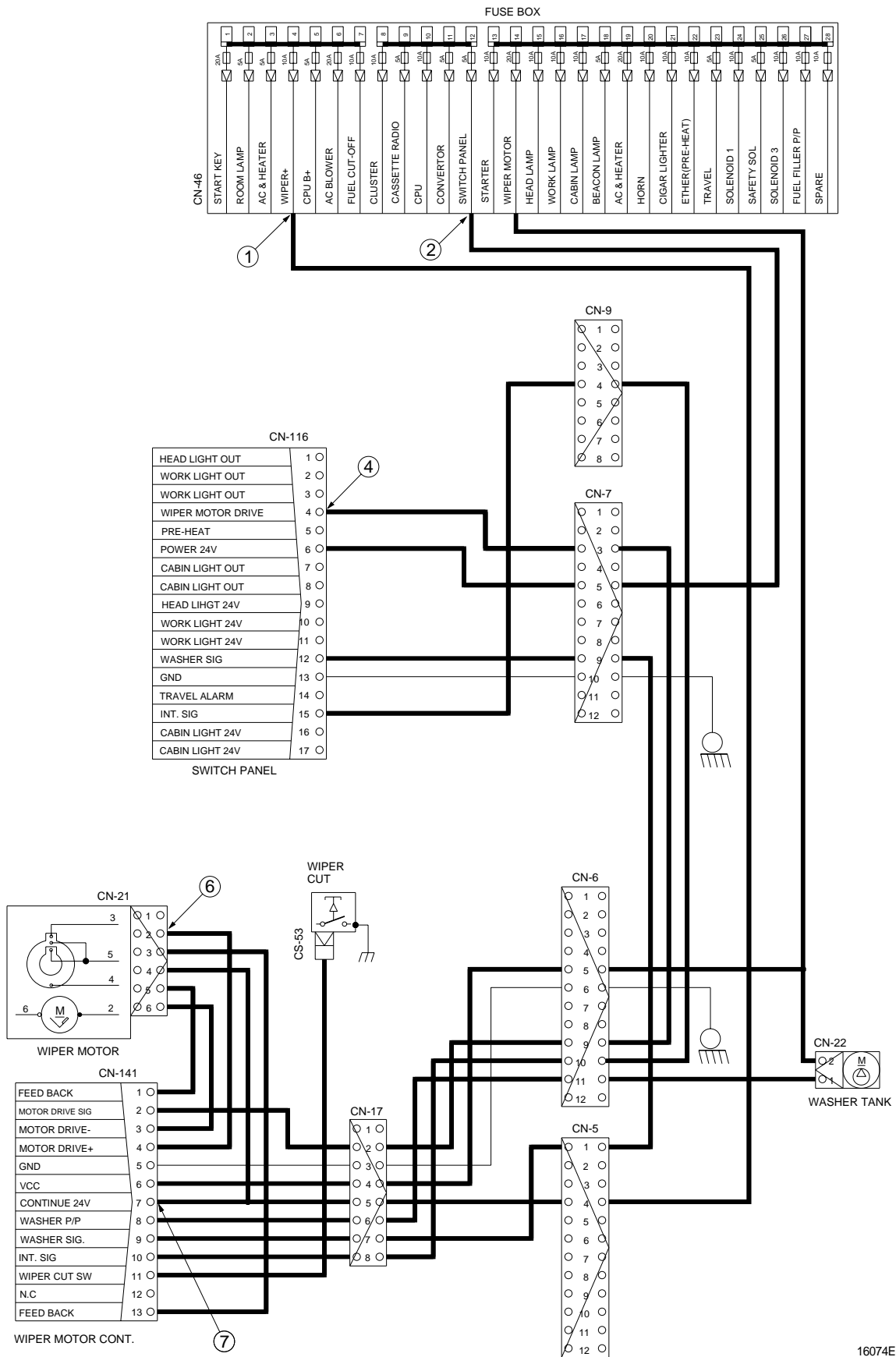

16074EL10

CONTROLLER CIRCUIT

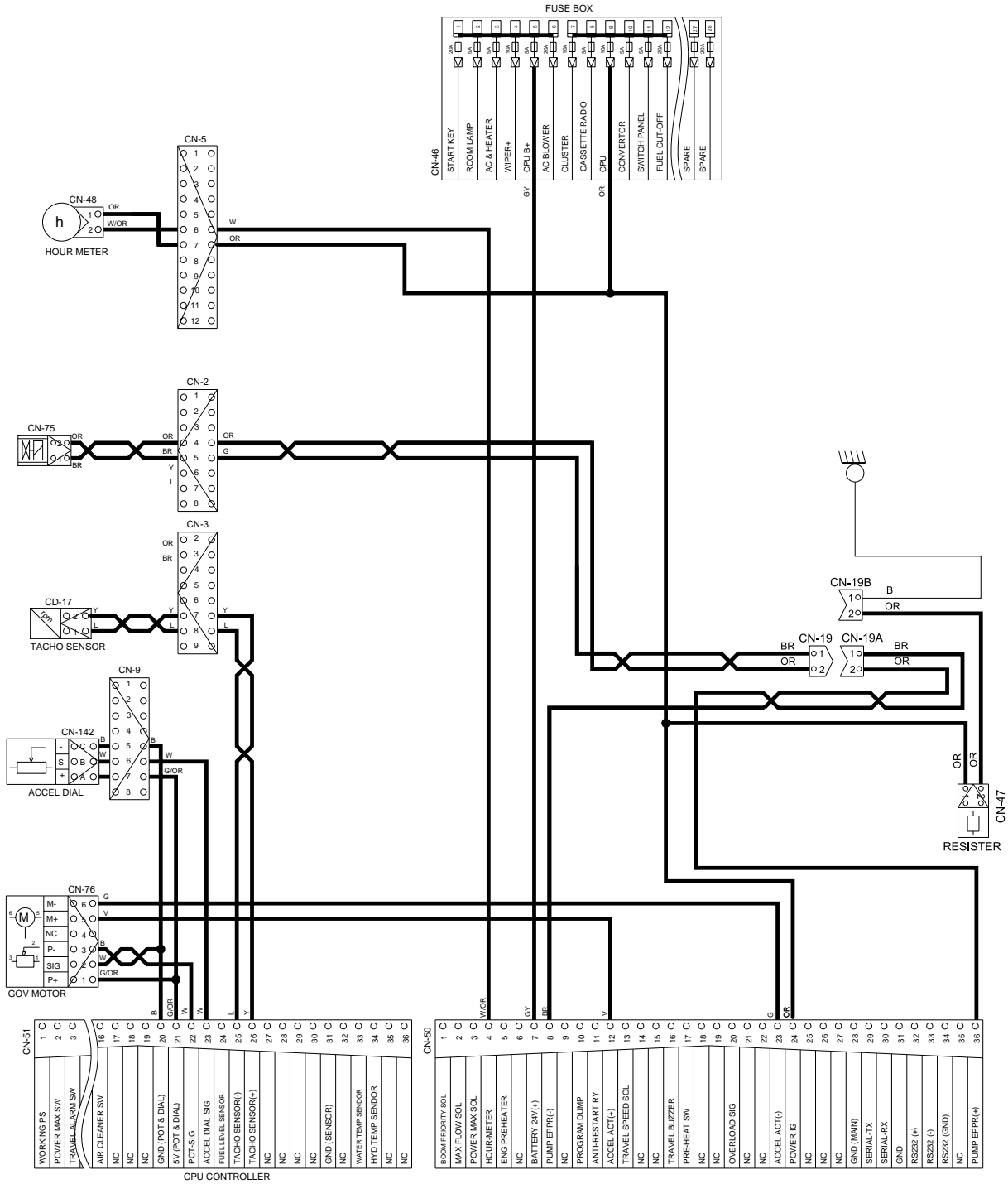

16074EL11

MONITORING CIRCUIT

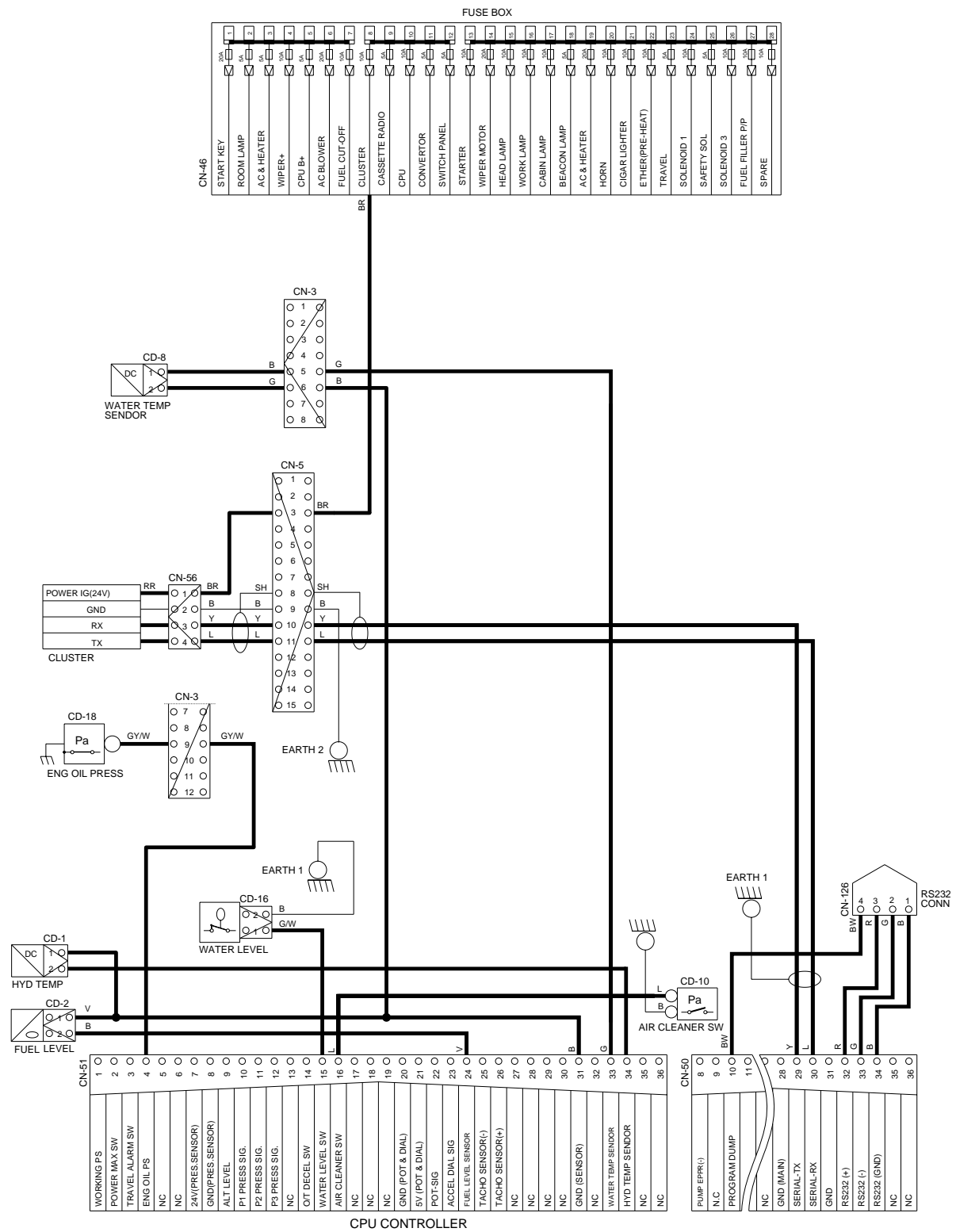

ELECTRIC CIRCUIT FOR HYDRAULIC

