

GROUP 11 ENGINE CONTROL SYSTEM

1. CPU CONTROLLER MOUNTING

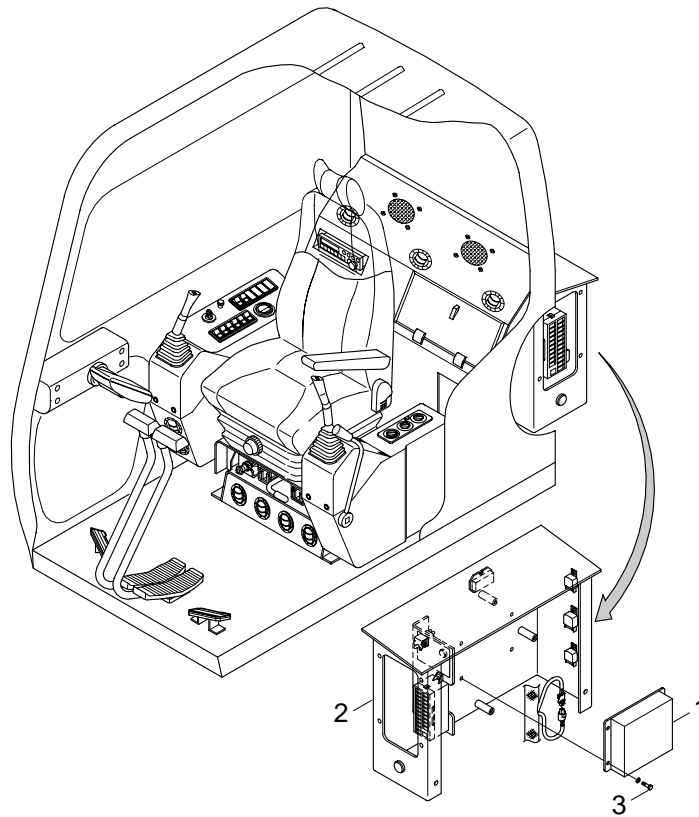

1 CPU controller

2 Electric box

3 Bolt(M8)

2. CPU CONTROLLER ASSEMBLY

- 1) Remove 4 CPU controller mounting bolt(3).
- 2) Disconnect 4 connectors from CPU controller.
- 3) Remove 6 pieces of screw and open the cover of CPU controller.
- 4) Inspection : Check PCB(Printed Circuit Board)
 - (1) If any damage is found, replace CPU controller assembly.
 - (2) If not, but CAPO system does not work then replace **A** only.(A : EPROM)
 - ※ Removal : Insert small screwdriver or knife to bottom of EPROM and lift up carefully.
 - ※ Assembly : Assemble EPROM to mach with semicircle mark.

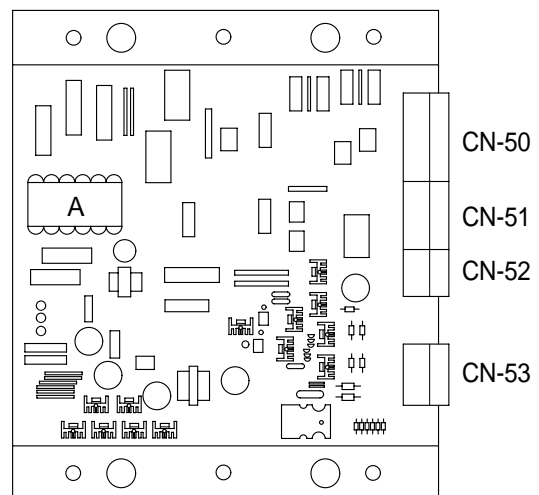

3. ENGINE GOVERNOR MOTOR

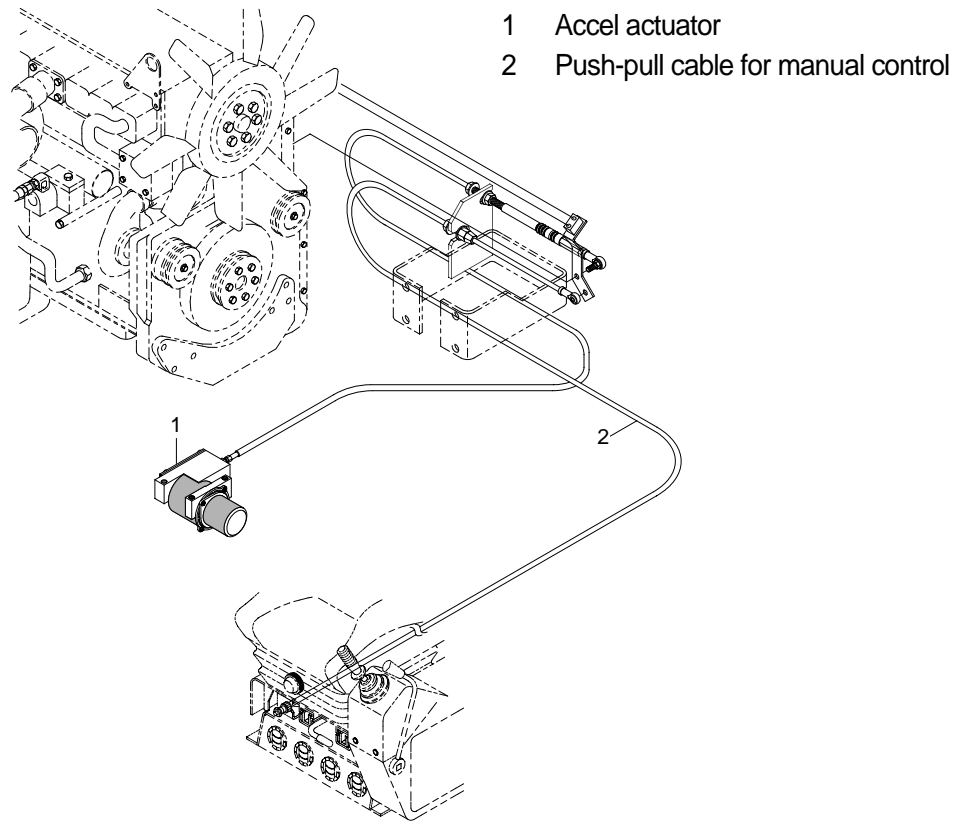

1) ENGINE THROTTLE LEVER

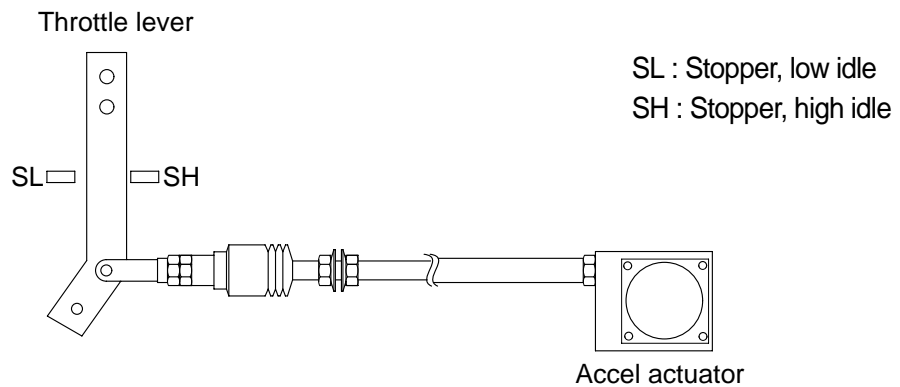

2) EMERGENCY CABLE (Push-pull cable)

It controls engine speed by connecting onto the lever of the injection pump when the malfunction of the CPU controller or the accel actuator happen.

2) ACCEL ACTUATOR

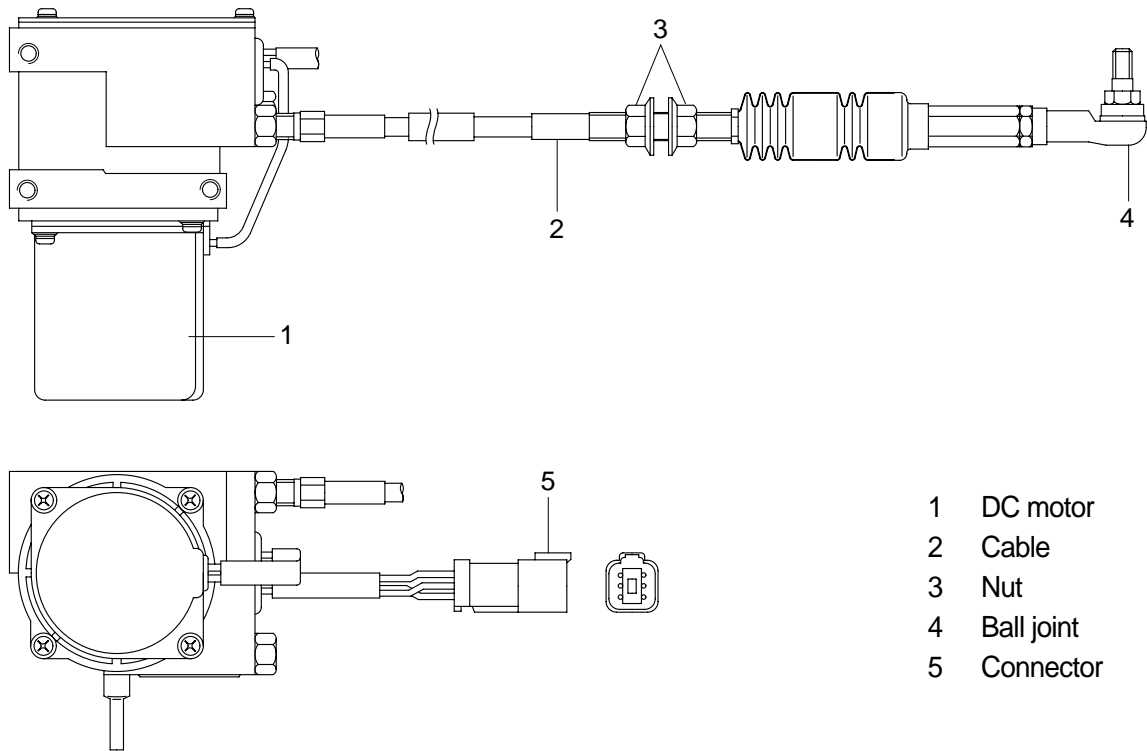

- 1 DC motor
- 2 Cable
- 3 Nut
- 4 Ball joint
- 5 Connector

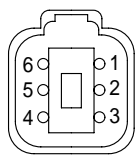
Connector		
Type	6P, female	
Line color & description	1	White(Potentiometer 5V)
	2	Blue(Potentiometer SIG)
	3	Black(Potentiometer GND)
	4	-
	5	Green(Motor+)
	6	Yellow(Motor -)
Inspection	Check resistance Spec : 1~2 Ω (Between No.5-6) 0.8~1.2kΩ (Between No.1-3)	

4. ENGINE SPEED SENSOR

1) DETECT ACTUAL ENGINE RPM AND SEND SIGNAL TO TACHOMETER

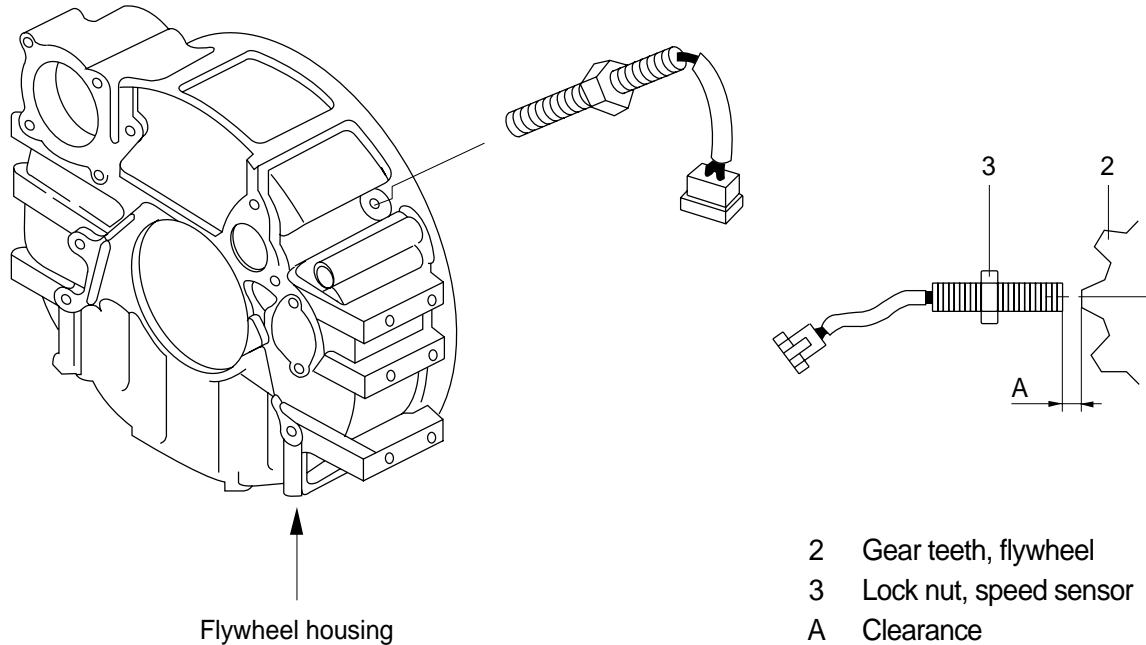

2) INSTALLATION

- (1) Clean contacting point of sensor.
- (2) Loosen lock nut.
- (3) Screw speed sensor into flywheel housing.
- (4) Turn it back 135° when it contacts with gear teeth.
- (5) Tight lock nut and connect wiring.

3) INSPECTION

- (1) Check resistance
 - SPEC : 300 Ω
- (2) Check voltage while engine run.
 - SPEC : 2~28Vac, dependent on the engine speed(rpm)