

# GROUP 2 ELECTRICAL CIRCUIT

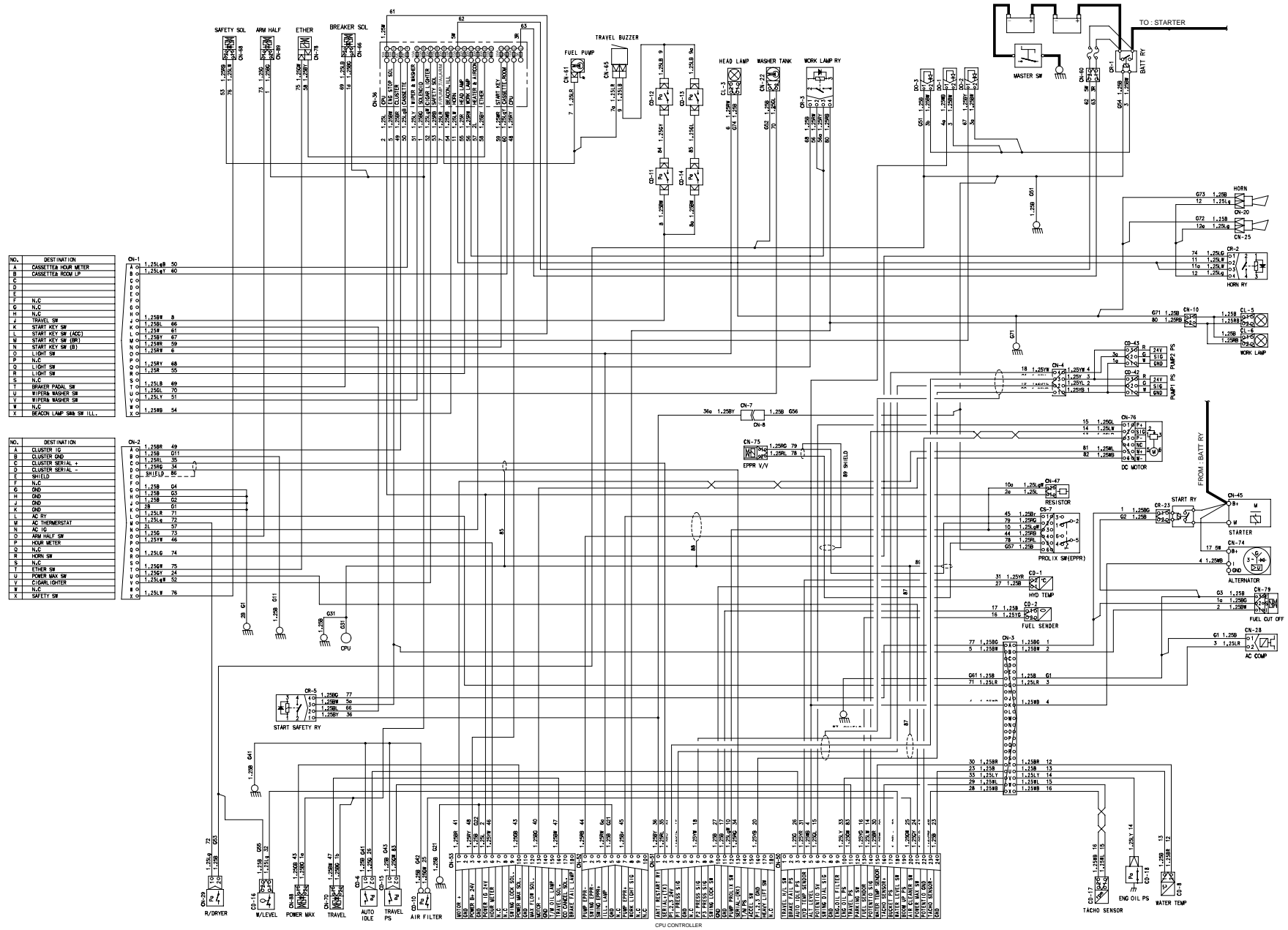

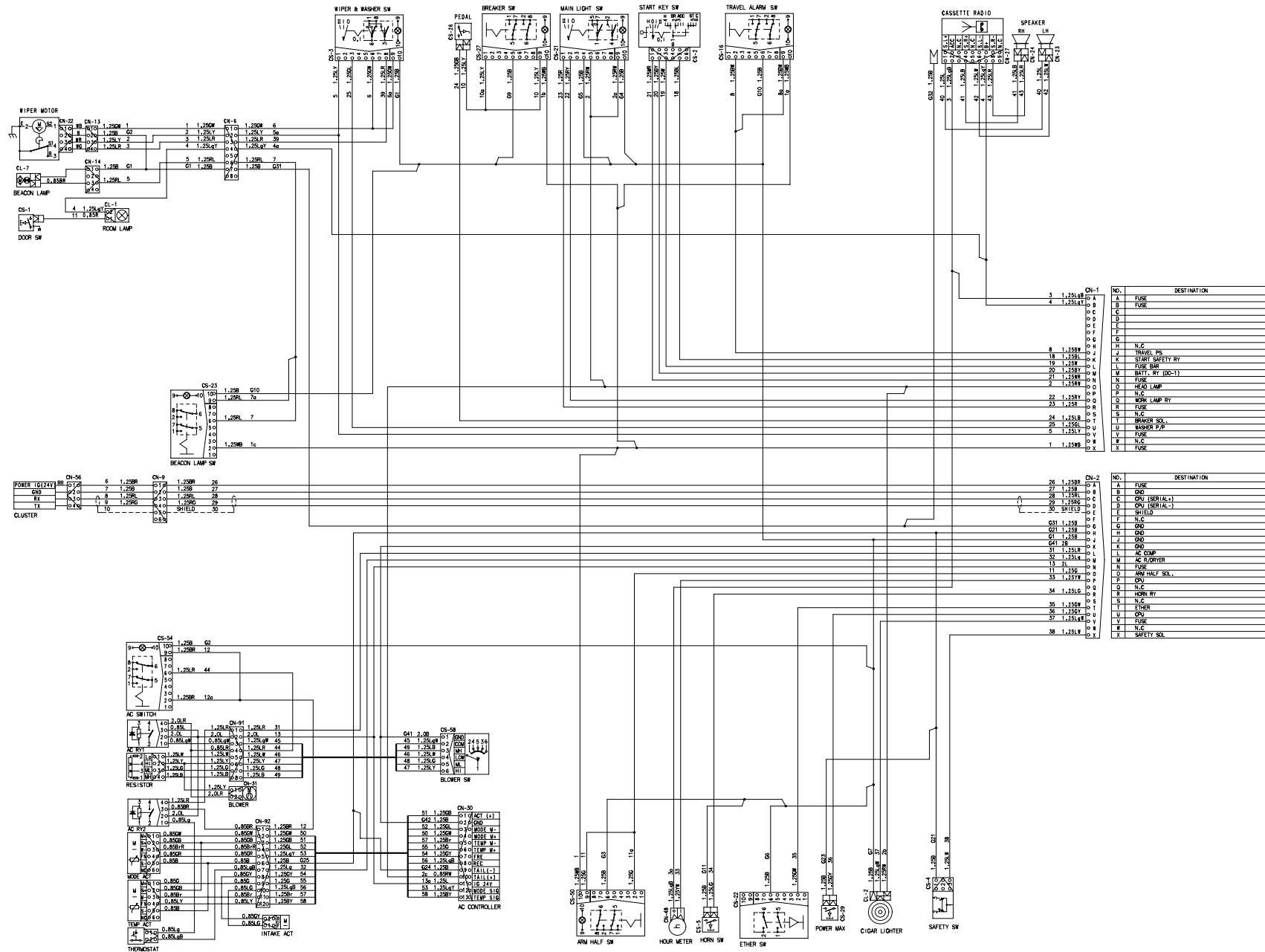

NO.	DESTINATION
A	FUSE
B	FUSE
C	
D	
E	
F	
G	
H	N/C
J	TRAVEL AL
K	SWT SAFETY RY
L	FUSE SWH
M	BATT. RY (DC-1)
N	FUSE
O	HEAD LAMP
P	N/C
Q	WORK LAMP RY
R	FUSE
S	N/C
T	BREAKER SW.
U	WASHER P.D.
V	FUSE
W	N/C
X	FUSE

NO.	DESTINATION
A	FUSE
B	GRD
C	CRU (SERIAL-1)
D	CRU (SERIAL-1)
E	SHIELD
F	N/C
G	GRD
H	GRD
J	GRD
K	GRD
L	AC COMP
M	AC DRIVER
N	FUSE
O	ARM HALF SW.
P	CRU
Q	N/C
R	HORN RY
S	N/C
T	ETHER
U	CRU
V	FUSE
W	N/C
X	SAFETY SW.

## 1. POWER CIRCUIT

The negative terminal of battery is grounded to the machine chassis through master switch.

When the start switch is in the OFF position, the current flows from the positive battery terminal as shown below.

### 1) OPERATING FLOW

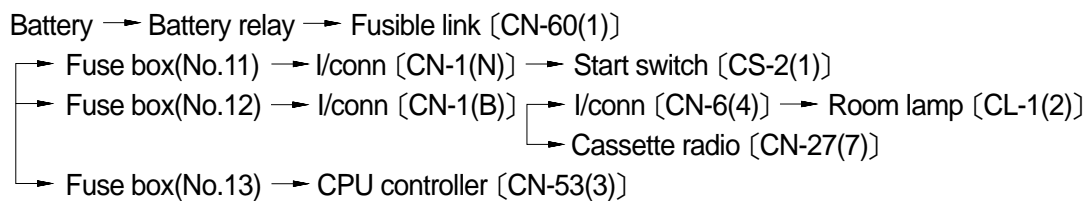

※ I/conn : Intermediate connector

### 2) CHECK POINT

Engine	Start switch	Check point	Voltage
OFF	OFF	①- GND(Battery 1EA) ②- GND(Battery 2EA) ③- GND(Battery 2EA) ④- GND(Fusible link)	10~12.5V 20~25V 20~25V 20~25V

※ GND : Ground



## 2. STARTING CIRCUIT

### 1) OPERATING FLOW

Battery(+) terminal → Battery relay(M8, B<sup>+</sup> terminal) → Fusible link [CN-60(1)]  
 → Fuse box(No.11) → I/conn [CN-1(N)] → Start switch [CS-2(1)]

#### (1) When start key switch is in ON position

→ Start switch ON [CS-2(2)] → I/conn [CN-1(M)] → Battery relay [M4 terminal]  
 → Battery relay operating(All power is supplied with the electric component)  
 → Start switch ON [CS-2(3)] → I/conn [CN-1(L)]  
 → Fuse box(No.1)  
 → Fuse box(No.2) → I/conn [CN-3(B)] → Fuel cut-off [CN-79(1)]

#### (2) When start key switch is in START position

Start switch START [CS-2(5)] → I/conn [CN-1(K)] → Start safety relay [CR-5(2)]  
 → I/conn [CN-3(A)] → Start relay [CR-23(1)]

## 2) CHECK POINT

Engine	Start switch	Check point	Voltage
OPERATING	START	①- GND(Battery) ②- GND(Start key) ③- GND(Battery relay M4) ④- GND(Start B+) ⑤- GND(Start M) ⑥- GND(Start relay) ⑦- GND(Battery relay M8)	20~25V

※ GND : Ground



### 3. CHARGING CIRCUIT

When the starter is activated and the engine is started, the operator releases the key switch to the ON position.

Charging current generated by operating alternator flows into the battery through the Battery relay(CR-1).

The current also flows from alternator to each electrical component and controller through the fuse box.

#### 1) OPERATING FLOW

##### (1) Warning flow

Alternator "I" terminal → I/conn [CN-3(K)] → CPU Alternator power level [CN-50(5)]  
→ Cluster charging warning lamp

##### (2) Charging flow

Alternator B+ terminal → Battery relay(M8) → Battery(+) terminal

#### 2) CHECK POINT

Engine	Start switch	Check point	Voltage
RUN	ON	①- GND(Battery voltage) ②- GND(Battery relay) ③- GND(Alternator B terminal) ④- GND(Alternator I terminal) ⑤- GND(CPU)	20~30V

※ GND : Ground





## 4. HEAD AND WORK LIGHT CIRCUIT

### 1) OPERATING FLOW

Fuse box(No.16) → I/conn [CN-1(R)] → Main light switch [CS-21(1)]

Fuse box(No.17) → Work light relay [CR-3(2, 3)]

#### (1) Head light switch ON : 1st step

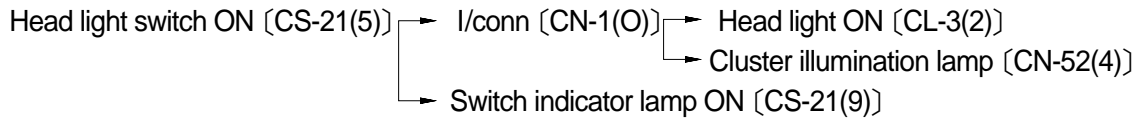

#### (2) Work light switch ON : 2nd step

Work light switch ON [CS-21(2)] → I/conn [CN-1(Q)] → Work light relay [CR-3(1)]

I/conn [CN-10(2)] → Work light ON [CL-6(2), CL-5(2)]

I/conn [CN-10(2)] → Cluster work light pilot lamp ON [CN-52(8)]

### 2) CHECK POINT

Engine	Start switch	Check point	Voltage
STOP	ON	①- GND(Fuse box) ③- GND(Switch power input) ⑤- GND(Switch power output) ⑦- GND(Head lamp)	20~25V
STOP	ON	②- GND(Fuse box) ④- GND(Switch signal input) ⑥- GND(Switch signal output) ⑧- GND(Relay coil) ⑨- GND(Relay power input) ⑩- GND(Relay power output) ⑪- GND(Work lamp)	20~25V

※ GND : Ground

# HEAD AND WORK LIGHT CIRCUIT

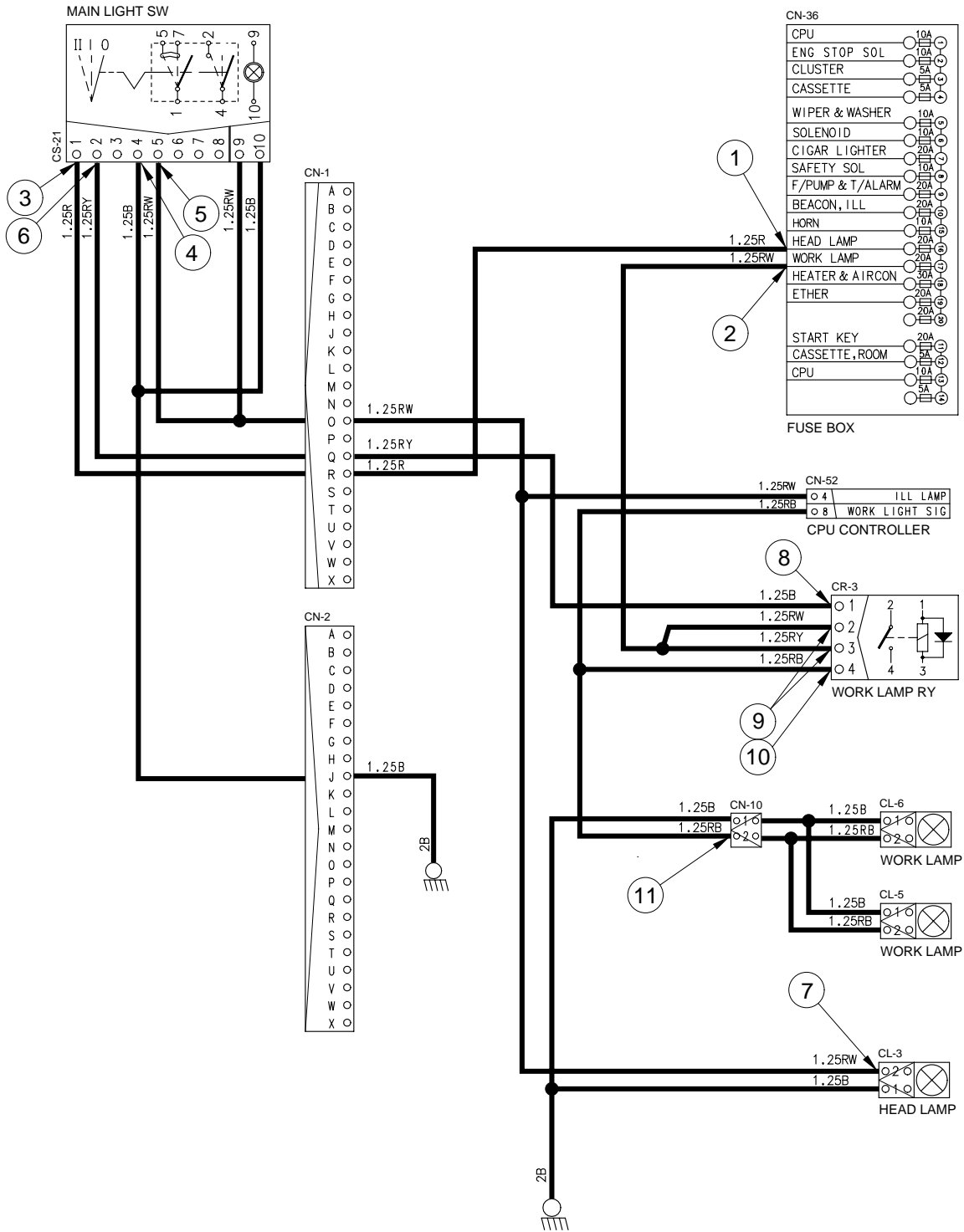

## 5. BEACON LAMP CIRCUIT

### 1) OPERATING FLOW

Fuse box(No.10) → I/conn [CN-1(X)] → Beacon lamp switch [CS-23(2)]

#### ※ When Lamp switch ON

Beacon lamp switch ON [CS-23(6)] → Switch indicator lamp ON [CS-23(9)]  
 → I/conn [CN-6(6)] → I/conn [CN-14(3)]  
 → Beacon lamp ON [CL-7]

### 2) CHECK POINT

Engine	Start switch	Check point	Voltage
STOP	ON	①- GND(Fuse box) ②- GND(Switch power input) ③- GND(Switch power output) ④- GND(Beacon lamp)	20~25V

※ GND : Ground

# BEACON LAMP CIRCUIT

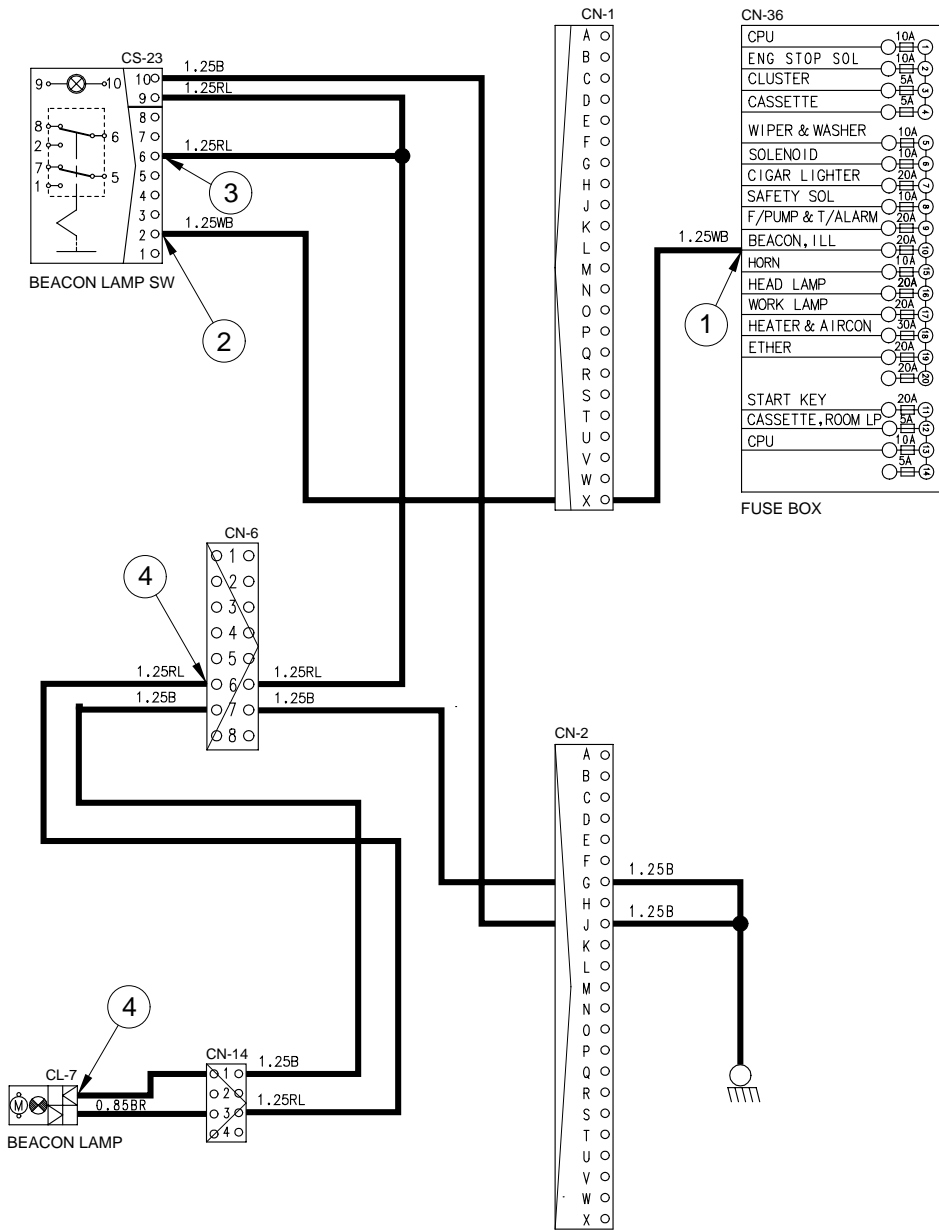

## 6. WIPER AND WASHER CIRCUIT

### 1) OPERATING FLOW

#### (1) Wiper motor switch ON : 1st step

Fuse box(No.5) → I/conn [CN-1(V)] → Wiper and washer switch [CS-3(1) → (6)]  
 → I/conn [CN-6(1)] → I/conn [CN-13(1)] → Wiper motor operation [CN-21(1)]

#### (2) Washer switch ON : 2nd step

Fuse box(No.5) → I/conn [CN-1(V)] → Wiper and washer switch [CS-3(1) → (3)]  
 → I/conn [CN-1(U)] → Washer tank [CN-22(2) → (1)]  
 → Washer operation  
 → I/conn [CN-6(1)] → I/conn [CN-13(1)]  
 → Wiper motor operation [CN-21(1)]

#### (3) Auto parking(When switch OFF)

Wiper & washer switch OFF [CS-3(6) → (8)] → Wiper motor [CN-21(1)]  
 → Fuse box(No.5) → I/conn [CN-1(V)] → I/conn [CN-6(2)] → I/conn [CN-13(3)]  
 → Wiper & washer switch [CN-21(3) → (4)] → Wiper motor stop

### 2) CHECK POINT

Engine	Start switch	Check point	Voltage
STOP	ON	①- GND(Fuse box) ②- GND(Switch power input) ③- GND(Switch power output) ④- GND(Wiper power input) ⑤- GND(Wiper power input) ⑥- GND(Wiper motor) ⑦- GND(Switch power output)	20~25V

※ GND : Ground



# CONTROLLER CIRCUIT

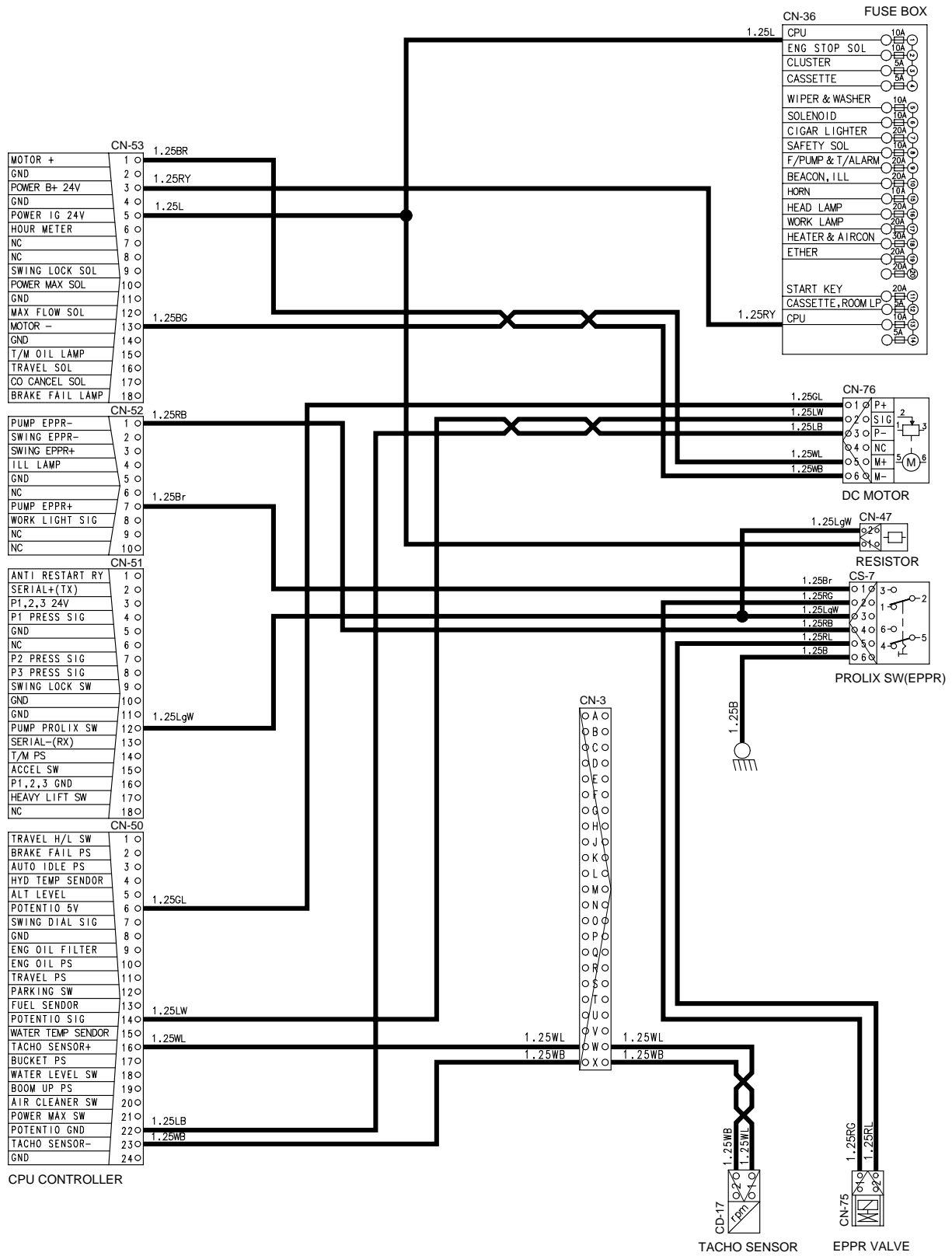

# ELECTRIC CIRCUIT FOR HYDRAULIC

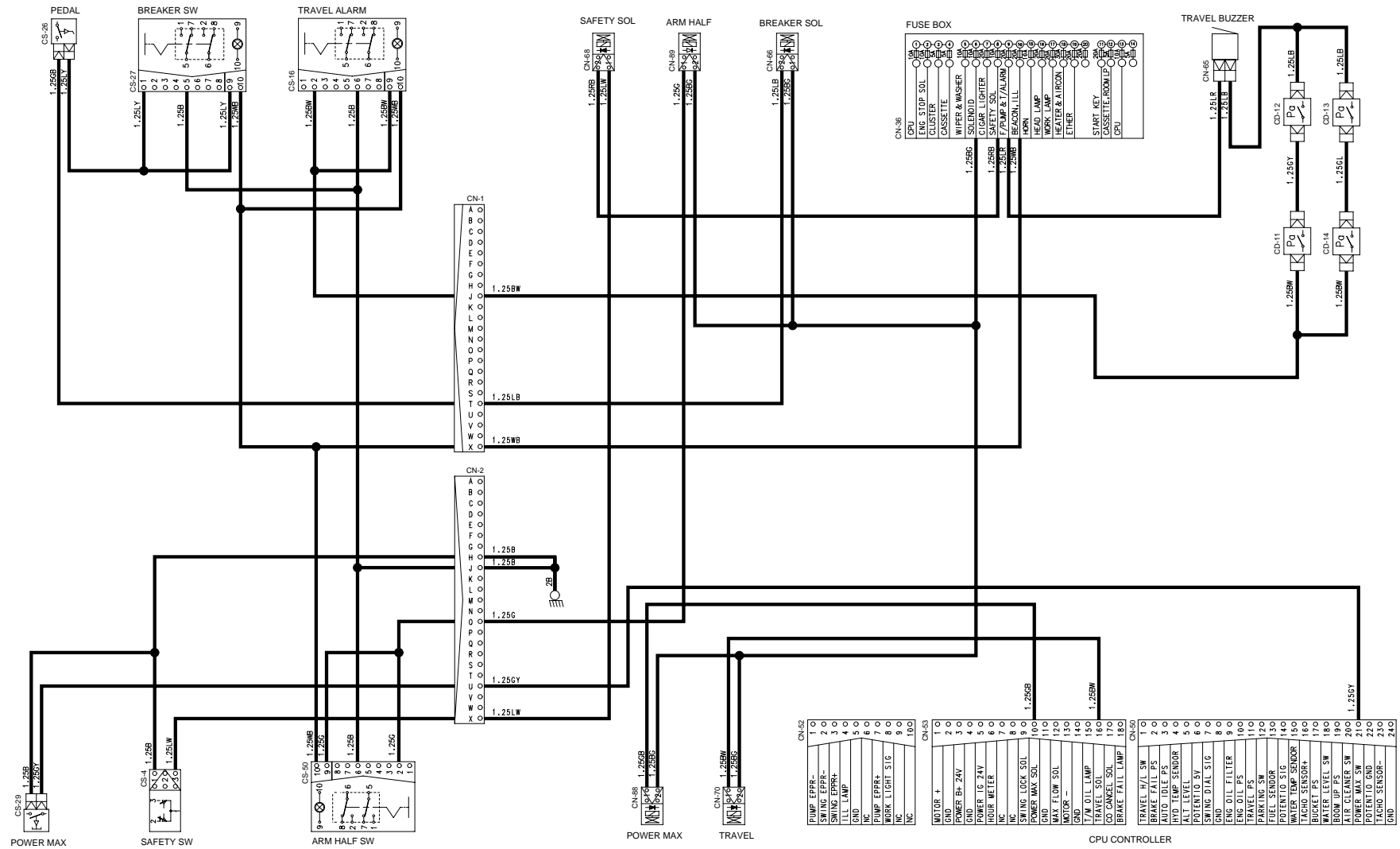



# MONITORING CIRCUIT

