

GROUP 3 TRACK AND WORK EQUIPMENT

1. TRACK

1) TRACK ROLLER (R160LC-9S, R180LC-9S : -#0491)

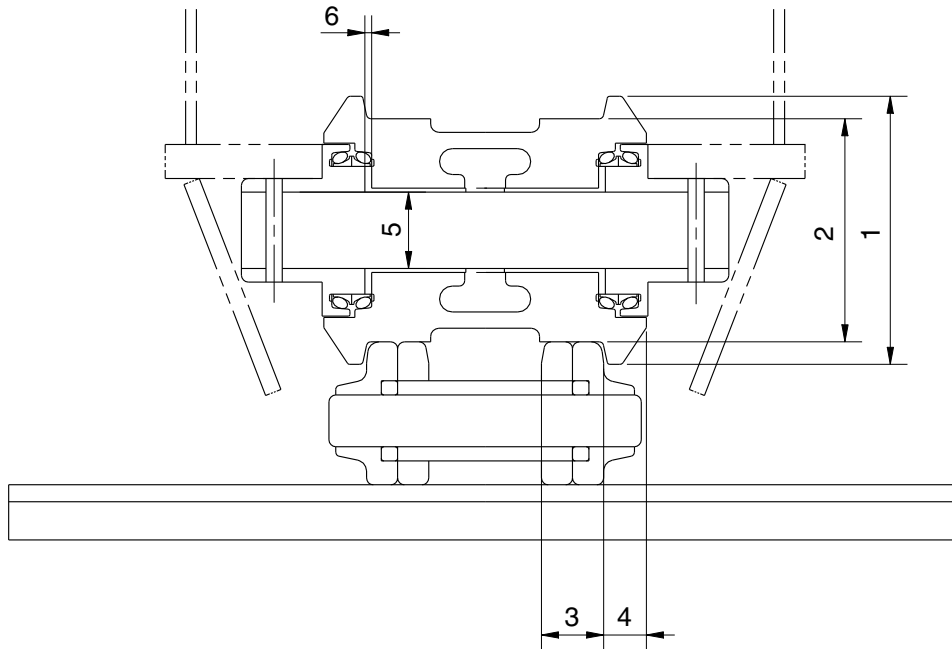

21037MS01

Unit : mm

No.	Check item	Criteria			Remedy
		Standard size		Repair limit	
1	Outside diameter of flange	Ø 195		-	Rebuild or replace
2	Outside diameter of tread	Ø 160		Ø 148	
3	Width of tread	44		50	
4	Width of flange	33.3		-	
5	Clearance between shaft and bushing	Standard size & tolerance		Standard clearance	Clearance limit
		Shaft	Hole		
		Ø70 $\begin{matrix} 0 \\ -0.03 \end{matrix}$	Ø70 $\begin{matrix} +0.35 \\ +0.3 \end{matrix}$	0.32 ~ 0.38	2.0
6	Side clearance of roller (both side)	Standard clearance		Clearance limit	
		0.26 ~ 1.22		2.0	

TRACK ROLLER (R180LC-9S : #0492-)

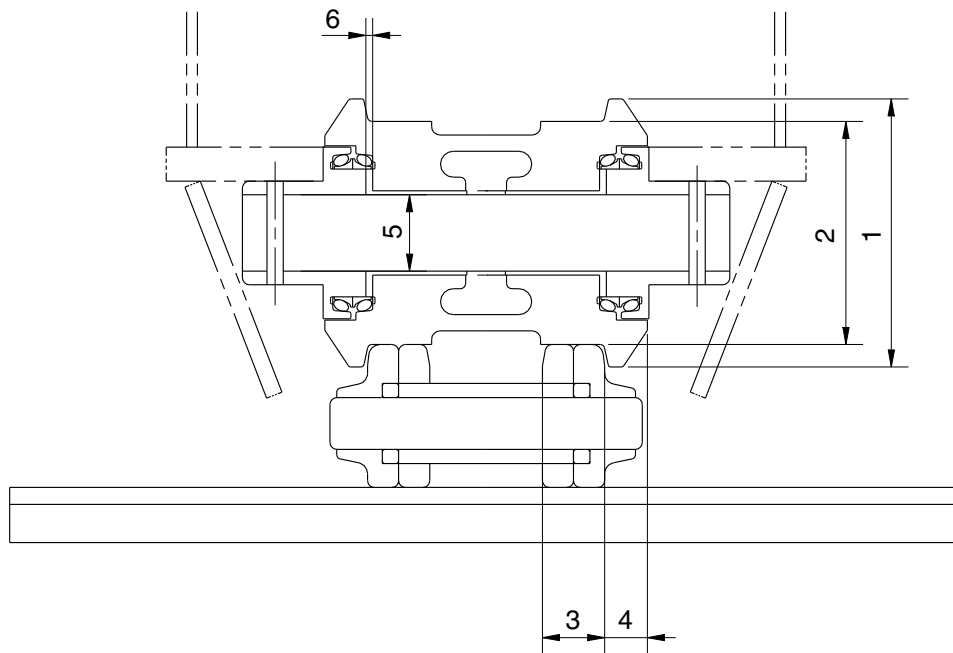

21037MS01

Unit : mm

No.	Check item	Criteria				Remedy
		Standard size		Repair limit		
1	Outside diameter of flange	Ø 185		-		Rebuild or replace
2	Outside diameter of tread	Ø 150		Ø 138		
3	Width of tread	45		51		
4	Width of flange	29		-		
5	Clearance between shaft and bushing	Standard size & tolerance		Standard clearance	Clearance limit	Replace bushing
		Shaft	Hole			
		Ø 65 $\begin{matrix} 0 \\ -0.3 \end{matrix}$	Ø 65 $\begin{matrix} +0.37 \\ +0.32 \end{matrix}$	0.32 ~ 0.4	2.0	
6	Side clearance of roller (both side)	Standard clearance		Clearance limit		Replace
		0.23 ~ 1.32		2.0		

2) CARRIER ROLLER

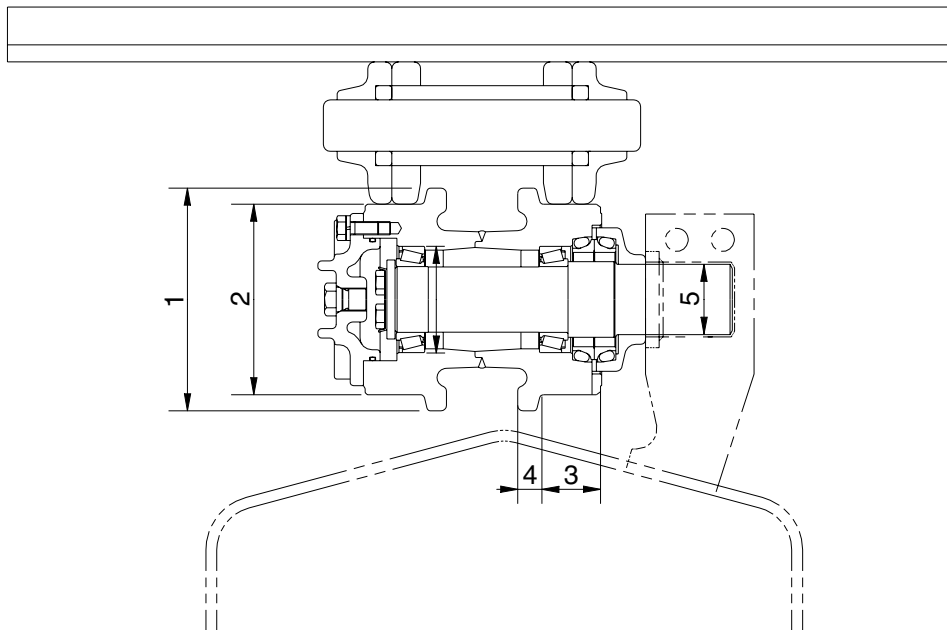

16077MSS02

Unit : mm

No.	Check item	Criteria			Remedy
		Standard size		Repair limit	
1	Outside diameter of flange	ø 169		ø 155	Rebuild or replace
2	Outside diameter of tread	ø 144		ø 134	
3	Width of tread	44		49	
4	Width of flange	17		-	
5	Clearance between shaft and bushing	Standard size & Tolerance		Standard clearance	Clearance limit
		Shaft	Hole		
		ø 55 -0.05 -0.1	ø 55 +0.3 +0.1	0.15 to 0.48	1.2

3) IDLER

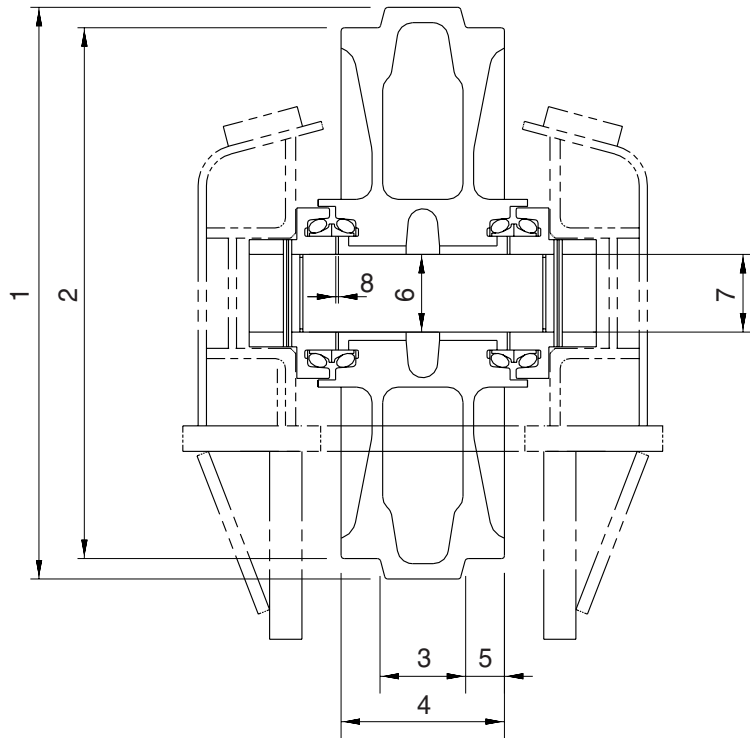

21037MS03

Unit : mm

No.	Check item	Criteria			Remedy	
		Standard size		Repair limit		
1	Outside diameter of flange	ø 560		-	Rebuild or replace	
2	Outside diameter of tread	ø 520		ø 510		
3	Width of protrusion	84		-		
4	Total width	160		-		
5	Width of tread	38		43		
6	Clearance between shaft and bushing	Standard size & Tolerance		Standard clearance	Clearance limit	
		Shaft	Hole			
		ø 75 $\begin{matrix} 0 \\ -0.03 \end{matrix}$	ø 75.35 $\begin{matrix} +0.05 \\ 0 \end{matrix}$	0.35 to 0.43	2.0	Replace bushing
7	Clearance between shaft and support	ø 750 $\begin{matrix} 0 \\ -0.03 \end{matrix}$	ø 75 $\begin{matrix} +0.07 \\ +0.03 \end{matrix}$	0.03 to 0.1	1.2	
8	Side clearance of idler (both side)	Standard clearance		Clearance limit		
		0.25 to 1.2		2.0		Replace bushing

4) TRACK

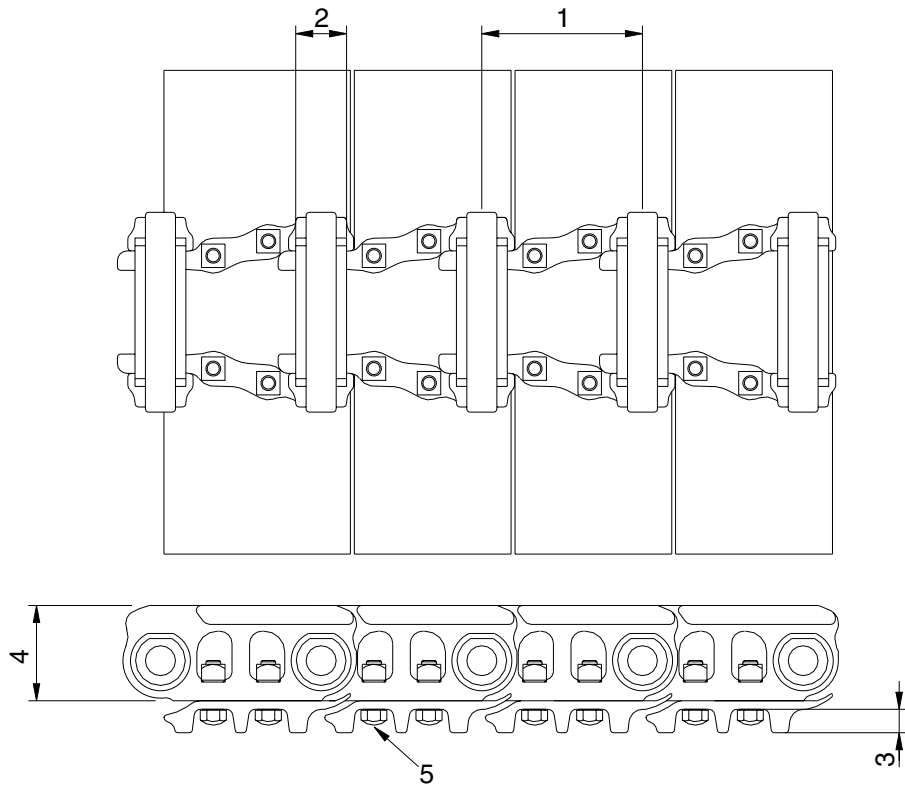

32077MS04

Unit : mm

No.	Check item	Criteria		Remedy
		Standard size	Repair limit	
1	Link pitch	171.45	178.95	Turn or replace
2	Outside diameter of bushing	∅ 54	∅ 46	
3	Height of grouser	25	16	Rebuild or replace
4	Height of link	101.6	93.6	
5	Tightening torque	Initial tightening torque : 40 ± 4 kgf · m		Retighten

5) TRACK FRAME AND RECOIL SPRING

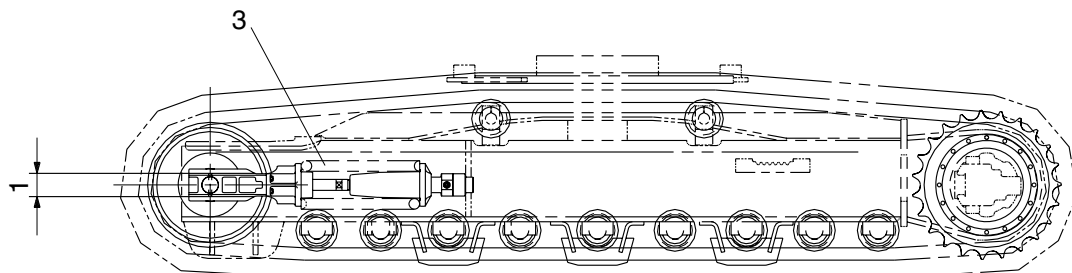
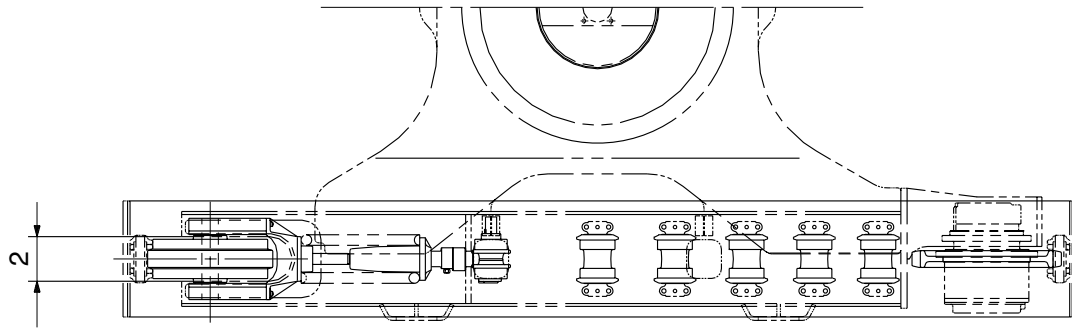

21037MS05

Unit : mm

No.	Check item	Criteria				Remedy	
			Standard size	Tolerance	Repair limit		
1	Vertical width of idler guide	Track frame	113	+2 0	117	Rebuild or replace	
		Idler support	110	-0.5 -1.0	106		
2	Horizontal width of idler guide	Track frame	272	+2 0	276		
		Idler support	270	-	267		
3	Recoil spring	Standard size		Repair limit		Replace	
		Free length	Installation length	Installation load	Free length		Installation load
		∅ 225 × 552	420	11,908kg	-		9,526kg

2. WORK EQUIPMENT

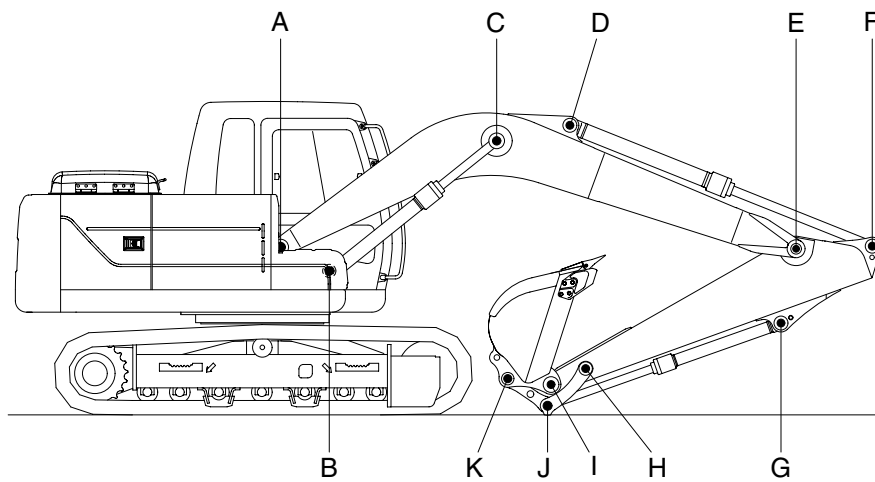

16097MS01

Unit : mm

Mark	Measuring point (Pin and Bushing)	Normal value	Pin		Bushing		Remedy & Remark
			Recomm. service limit	Limit of use	Recomm. service limit	Limit of use	
A	Boom Rear	75	74	73.5	75.5	76	Replace
B	Boom Cylinder Head	70	69	68.5	70.5	71	"
C	Boom Cylinder Rod	75	74	73.5	75.5	76	"
D	Arm Cylinder Head	70	69	68.5	70.5	71	"
E	Boom Front	75	74	73.5	75.5	76	"
F	Arm Cylinder Rod	70	69	68.5	70.5	71	"
G	Bucket Cylinder Head	70	69	68.5	70.5	71	"
H	Arm Link	70	69	68.5	70.5	71	"
I	Bucket and Arm Link	70	69	68.5	70.5	71	"
J	Bucket Cylinder Rod	70	69	68.5	70.5	71	"
K	Bucket Link	70	69	68.5	70.5	71	"