

GROUP 3 SPECIFICATIONS (R180LC-9S)

1. MAJOR COMPONENT

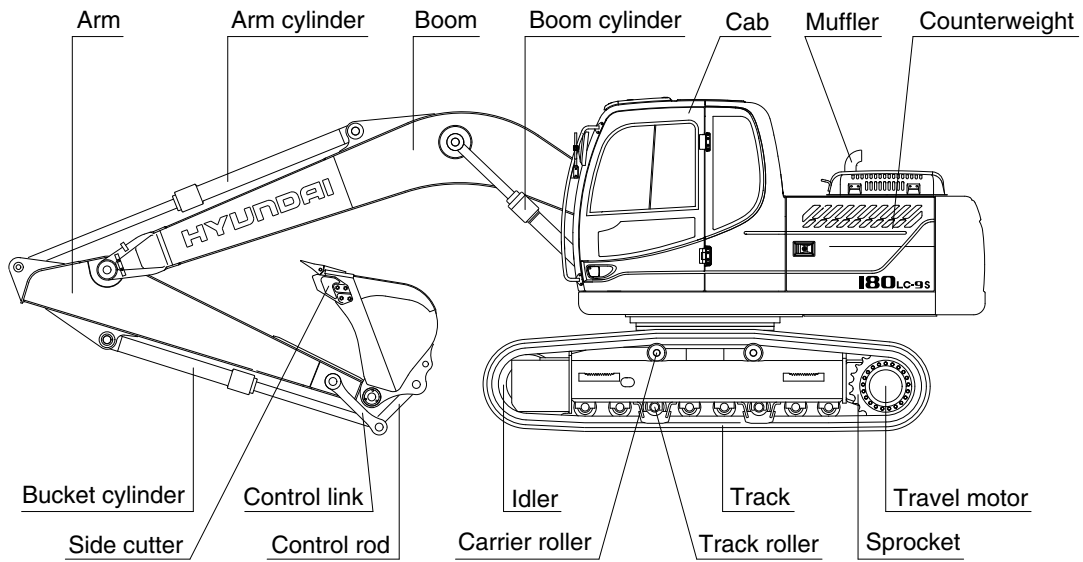
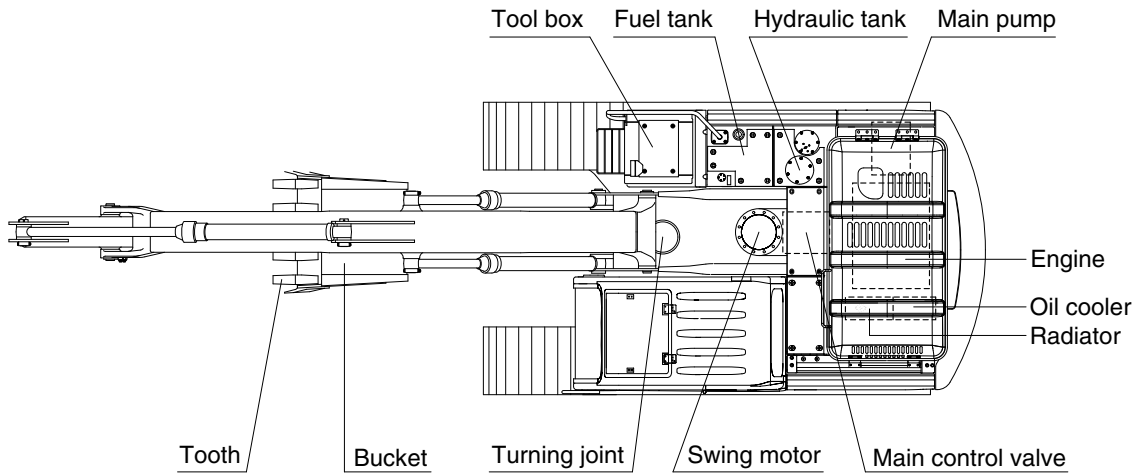

1809S2SP01

2. SPECIFICATIONS

1) R180LC-9S

· 5.1 m (16' 9") BOOM and 2.6 m (8' 6") ARM

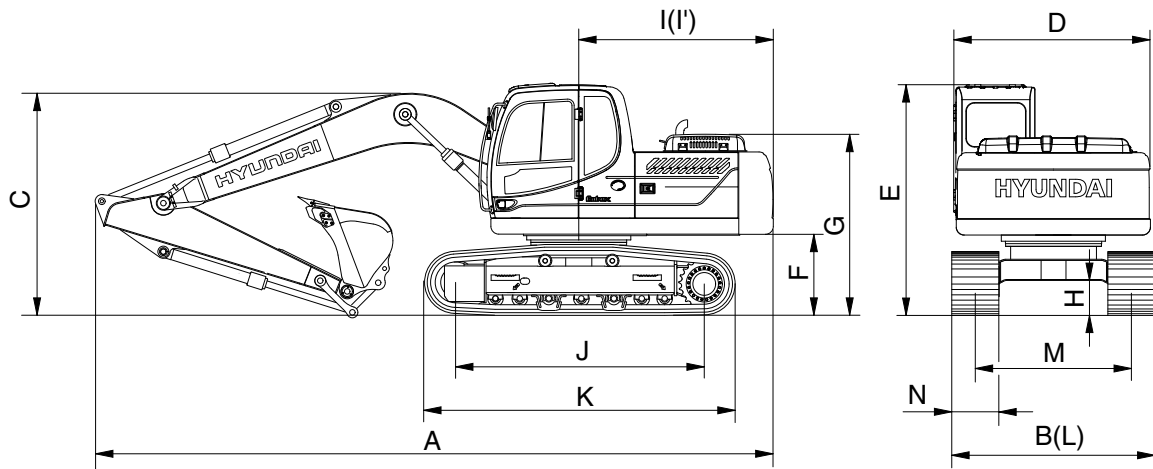

16092SP02

Description		Unit	Specification
Operating weight		kg (lb)	18600 (41010)
Bucket capacity (SAE heaped), standard		m ³ (yd ³)	0.76 (0.99)
Overall length	A	mm (ft-in)	8650 (28' 5")
Overall width, with 600 mm shoe	B		2850 (9' 4")
Overall height	C		2990 (9' 10")
Superstructure width	D		2475 (8' 1")
Overall height of cab	E		2980 (9' 9")
Ground clearance of counterweight	F		1055 (3' 6")
Engine cover height	G		2315 (7' 7")
Minimum ground clearance	H		460 (1' 6")
Rear-end distance	I		2480 (8' 2")
Rear-end swing radius	I'		2530 (8' 4")
Distance between tumblers	J		3360 (11' 0")
Undercarriage length	K		4150 (13' 7")
Undercarriage width	L		2850 (9' 4")
Track gauge	M		2250 (7' 5")
Track shoe width, standard	N		600 (24")
Travel speed (low/high)			km/hr (mph)
Swing speed		rpm	11
Gradeability		Degree (%)	30 (58)
Ground pressure (600 mm shoe)		kgf/cm ² (psi)	0.43 (6.11)
Max traction force		kg (lb)	17000 (37500)

2) R180LC-9S

· 5.1 m (16' 9") HYDRAULIC ADJUSTABLE BOOM AND 2.6 m (8' 6") ARM

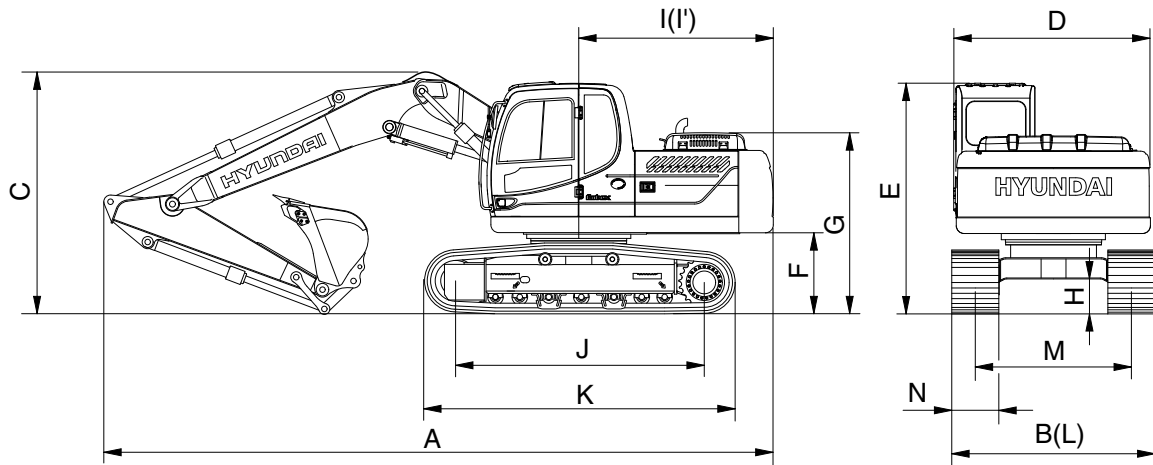

16092SP03

Description		Unit	Specification
Operating weight		kg (lb)	19090 (42090)
Bucket capacity (SAE heaped), standard		m ³ (yd ³)	0.76 (0.99)
Overall length	A	mm (ft-in)	8610 (28' 3")
Overall width, with 600 mm shoe	B		2850 (9' 4")
Overall height	C		3060 (10' 0")
Superstructure width	D		2475 (8' 1")
Overall height of cab	E		2980 (9' 9")
Ground clearance of counterweight	F		1055 (3' 6")
Engine cover height	G		2315 (7' 7")
Minimum ground clearance	H		460 (1' 6")
Rear-end distance	I		2480 (8' 2")
Rear-end swing radius	I'		2530 (8' 4")
Distance between tumblers	J		3360 (11' 0")
Undercarriage length	K		4150 (13' 7")
Undercarriage width	L		2850 (9' 4")
Track gauge	M		2250 (7' 5")
Track shoe width, standard	N		600 (24")
Travel speed (low/high)			km/hr (mph)
Swing speed		rpm	11
Gradeability		Degree (%)	30 (58)
Ground pressure (600 mm shoe)		kgf/cm ² (psi)	0.44 (6.26)
Max traction force		kg (lb)	17000 (37500)

3) R180LCD-9S

• 5.1 m (16' 9") BOOM and 2.6 m (8' 6") ARM

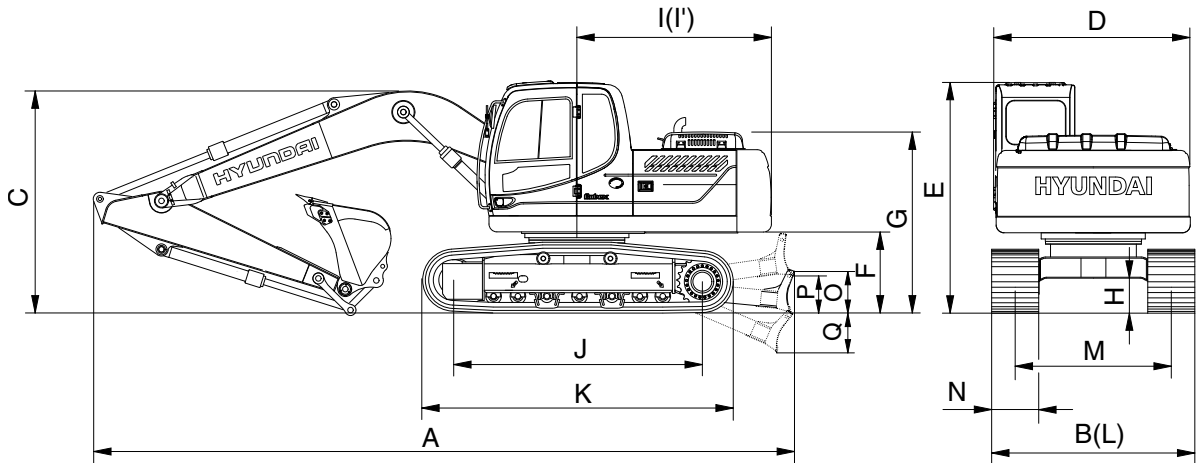

16092SP04

Description		Unit	Specification
Operating weight		kg (lb)	19660 (43210)
Bucket capacity (SAE heaped), standard		m ³ (yd ³)	0.76 (0.99)
Overall length	A	mm (ft-in)	9100 (29' 10")
Overall width, with 600 mm shoe	B		2850 (9' 4")
Overall height	C		2990 (9'10")
Superstructure width	D		2475 (8' 1")
Overall height of cab	E		2980 (9' 9")
Ground clearance of counterweight	F		1055 (3' 6")
Engine cover height	G		2315 (7' 7")
Minimum ground clearance	H		460 (1' 6")
Rear-end distance	I		2480 (8' 2")
Rear-end swing radius	I'		2530 (8' 4")
Distance between tumblers	J		3360 (11' 0")
Undercarriage length	K		4150 (13' 7")
Undercarriage width	L		2850 (9' 4")
Track gauge	M		2250 (7' 5")
Track shoe width, standard	N		600 (24")
Height of blade	O		640 (2' 1")
Ground clearance of blade up	P		615 (2' 0")
Depth of blade down	Q		675 (2' 3")
Travel speed (low/high)			km/hr (mph)
Swing speed		rpm	11
Gradeability		Degree (%)	30 (58)
Ground pressure (600 mm shoe)		kgf/cm ² (psi)	0.45 (6.40)
Max traction force		kg (lb)	17000 (37500)

4) R180NLC-9S

• 5.1 m (16' 9") BOOM and 2.6 m (8' 6") ARM

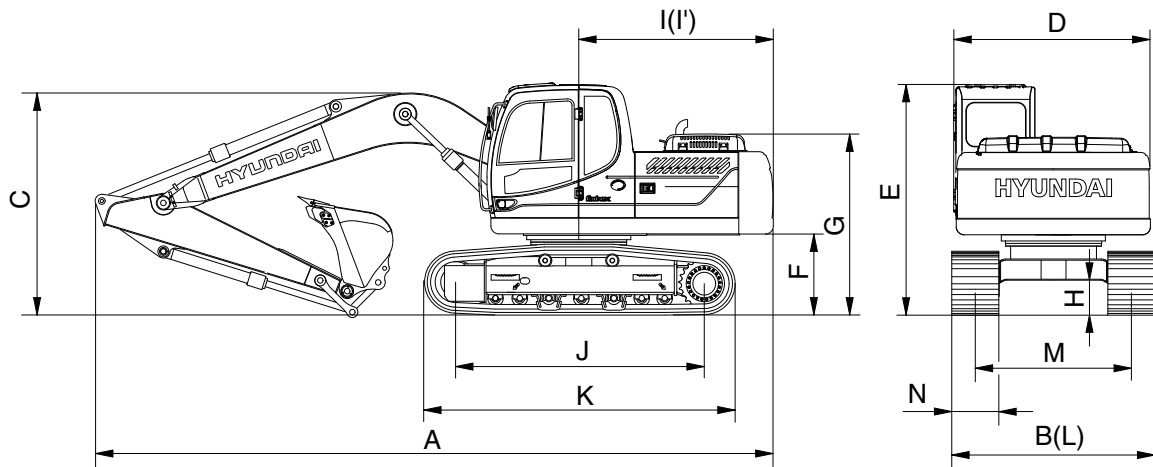

16092SP02

Description		Unit	Specification
Operating weight		kg (lb)	18510 (40810)
Bucket capacity (SAE heaped), standard		m ³ (yd ³)	0.76 (0.99)
Overall length	A	mm (ft-in)	8650 (28' 5")
Overall width, with 600 mm shoe	B		2600 (8' 6")
Overall height	C		2990 (9'10")
Superstructure width	D		2475 (8' 1")
Overall height of cab	E		2980 (9' 9")
Ground clearance of counterweight	F		1055 (3' 6")
Engine cover height	G		2315 (7' 7")
Minimum ground clearance	H		460 (1' 6")
Rear-end distance	I		2480 (8' 2")
Rear-end swing radius	I'		2530 (8' 4")
Distance between tumblers	J		3360 (11' 0")
Undercarriage length	K		4150 (13' 7")
Undercarriage width	L		2600 (8' 6")
Track gauge	M		2000 (6' 7")
Track shoe width, standard	N		600 (24")
Travel speed (low/high)		km/hr (mph)	3.2/5.2 (2.0/3.2)
Swing speed		rpm	11
Gradeability		Degree (%)	30 (58)
Ground pressure (600 mm shoe)		kgf/cm ² (psi)	0.42 (5.97)
Max traction force		kg (lb)	17000 (37500)

3. WORKING RANGE

1) 5.1 m (16' 9") MONO BOOM

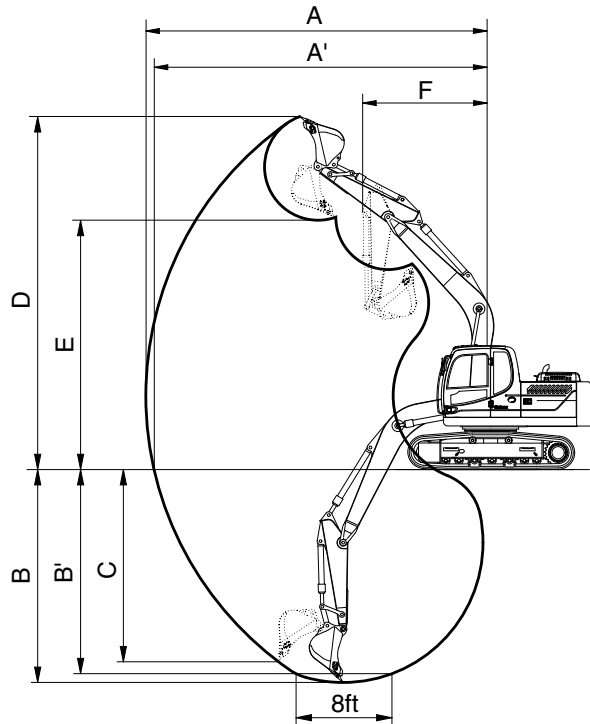

16092SP05

Description		2.2 m (7' 3") Arm	2.6 m (8' 6") Arm	3.1 m (10' 2") Arm
Max digging reach	A	8690 mm (28' 6")	9020 mm (29' 7")	9450 mm (31' 0")
Max digging reach on ground	A'	8530 mm (27'12")	8860 mm (29' 1")	9300 mm (30' 6")
Max digging depth	B	5660 mm (18' 7")	6060 mm (19'11")	6560 mm (21' 6")
Max digging depth (8 ft level)	B'	5430 mm (17'10")	5850 mm (19' 2")	6370 mm (20'11")
Max vertical wall digging depth	C	5120 mm (16'10")	5380 mm (17' 8")	5710 mm (18' 9")
Max digging height	D	8750 mm (28' 8")	8840 mm (29' 0")	8980 mm (29' 6")
Max dumping height	E	6110 mm (20' 1")	6220 mm (20' 5")	6390 mm (21' 0")
Min swing radius	F	3180 mm (10' 5")	3170 mm (10' 5")	3170 mm (10' 5")
Bucket digging force	SAE	107.9 [117.2] kN	107.9 [117.2] kN	107.9 [117.2] kN
		11000 [11940] kgf	11000 [11940] kgf	11000 [11940] kgf
		24250 [26330] lbf	24250 [23660] lbf	24250 [26330] lbf
	ISO	123.6 [134.2] kN	123.6 [134.2] kN	123.6 [134.2] kN
		12600 [13680] kgf	12600 [13680] kgf	12600 [13680] kgf
		27780 [30160] lbf	27780 [30160] lbf	27780 [30160] lbf
Arm crowd force	SAE	87.2 [94.7] kN	77.3 [83.9] kN	69.0 [74.9] kN
		8890 [9650] kgf	7880 [8560] kgf	7030 [7630] kgf
		19600 [21280] lbf	17370 [18860] lbf	15500 [16830] lbf
	ISO	91.0 [98.8] kN	80.3 [87.2] kN	71.4 [77.5] kN
		9280 [10080] kgf	8190 [8890] kgf	7280 [7900] kgf
		20460 [22210] lbf	18060 [19600] lbf	16050 [17430] lbf

[] : Power boost

2) 5.1 m (16' 9") HYDRAULIC ADJUSTABLE BOOM

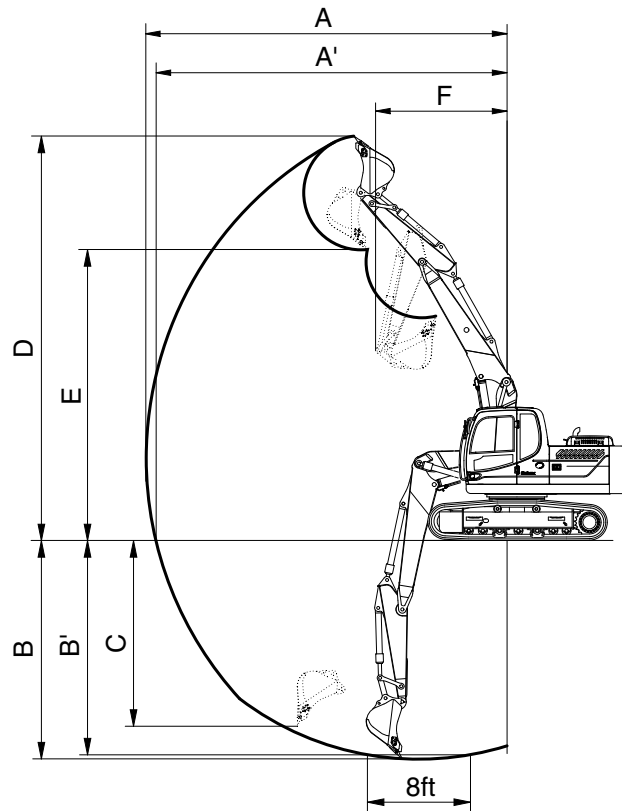

16092SP06

Description		2.2 m (7' 3") Arm	2.6 m (8' 6") Arm
Max digging reach	A	8760 mm (28' 9")	9110 mm (29' 11")
Max digging reach on ground	A'	8590 mm (28' 2")	8950 mm (29' 4")
Max digging depth	B	5430 mm (17' 10")	5830 mm (19' 2")
Max digging depth (8ft level)	B'	5330 mm (17' 6")	5730 mm (18' 10")
Max vertical wall digging depth	C	4630 mm (15' 2")	4980 mm (16' 4")
Max digging height	D	9420 mm (30' 11")	9610 mm (31' 6")
Max dumping height	E	6710 mm (22' 0")	6910 mm (22' 8")
Min swing radius	F	3100 mm (10' 2")	2970 mm (9' 9")
Bucket digging force	SAE	107.9 [117.2] kN	107.9 [117.2] kN
		11000 [11940] kgf	11000 [11940] kgf
		24250 [26330] lbf	24250 [26330] lbf
	ISO	123.6 [134.2] kN	123.6 [134.2] kN
		12600 [13680] kgf	12600 [13680] kgf
		27780 [30160] lbf	27780 [30160] lbf
Arm crowd force	SAE	87.2 [94.7] kN	77.3 [83.9] kN
		8890 [9650] kgf	7880 [8560] kgf
		19600 [21280] lbf	17370 [18860] lbf
	ISO	91.0 [98.8] kN	80.3 [87.2] kN
		9280 [10080] kgf	8190 [8890] kgf
		20460 [22210] lbf	18060 [19600] lbf

[] : Power boost



4. WEIGHT













Item	R180LC-9S		R180LCD-9S		180NLC-9S	
	kg	lb	kg	lb	kg	lb
Upper structure assembly	7880	17370	←		←	
Main frame weld assembly	1470	3240	←		←	
Engine assembly	440	970	←		←	
Fan clutch assembly	45	100	←		←	
Main pump assembly	100	220	←		←	
Main control valve assembly	140	310	←		←	
Swing motor assembly	250	550	←		←	
Hydraulic oil tank assembly	165	360	←		←	
Fuel tank assembly	130	290	←		←	
Counterweight	2900	6390	←		←	
Cab assembly	440	970	←		←	
Lower chassis assembly	7670	16910	8670	19110	7580	16710
Track frame weld assembly	2130	4700	2370	5230	1980	4370
Swing bearing	260	570	←		←	
Travel motor assembly	300	660	←		←	
Turning joint	60	130	←		←	
Track recoil spring	140	310	←		←	
Idler	160	350	←		←	
Carrier roller	20	45	←		←	
Track roller	40	90	←		←	
Track-chain assembly (600 mm standard triple grouser shoe)	1180	2600	←		←	
Front attachment assembly (5.1 m boom, 2.6 m arm, 0.76 m ³ SAE heaped bucket)	3020	6660	←		←	
5.1 m boom assembly	1060	2340	←		←	
2.6 m arm assembly	560	1240	←		←	
0.76 m ³ SAE heaped bucket	570	1260	←		←	
Boom cylinder assembly	155	340	←		←	
Arm cylinder assembly	180	400	←		←	
Bucket cylinder assembly	125	260	←		←	
Bucket control link assembly	120	265	←		←	
Dozer blade assembly	-	-	715	1575	-	-
Dozer blade cylinder assembly	-	-	66	146	-	-

5. LIFTING CAPACITIES

1) R180LC-9S

(1) 5.1 m (16' 9") boom, 2.6 m (8' 6") arm equipped with 0.76 m³ (SAE heaped) bucket and 600 mm (24") triple grouser shoe and 2900 kg (6390 lb) counterweight.

-  : Rating over-front
-  : Rating over-side or 360 degree

Load point height		Load radius										At max. reach					
		1.5 m (5.0 ft)		3.0 m (10.0 ft)		4.5 m (15.0 ft)		6.0 m (20.0 ft)		7.5 m (25.0 ft)		Capacity		Reach			
														m (ft)			
7.5 m (25.0 ft)	kg														*3380	*3380	6.11
	lb														*7450	*7450	(20.0)
6.0 m (20.0 ft)	kg							*3020	*3020			*3360	2660	7.37			
	lb							*6660	*6660			*7410	5860	(24.2)			
4.5 m (15.0 ft)	kg							*3770	3720			*3410	2190	8.11			
	lb							*8310	8200			*7520	4830	(26.6)			
3.0 m (10.0 ft)	kg			*7910	*7910	*5310	*5310	*4300	3560	*2810	2420	3130	1970	8.48			
	lb			*17440	*17440	*11710	*11710	*9480	7850	*6190	5340	6900	4340	(27.8)			
1.5 m (5.0 ft)	kg			*8120	*8120	*6650	5270	*4920	3380	*3650	2350	3050	1900	8.53			
	lb			*17900	*17900	*14660	11620	*10850	7450	*8050	5180	6720	4190	(28.0)			
Ground Line	kg			*7910	*7910	*7500	5010	5220	3240	*3470	2280	3170	1970	8.28			
	lb			*17440	*17440	*16530	11050	11510	7140	*7650	5030	6990	4340	(27.2)			
-1.5 m (-5.0 ft)	kg	*6710	*6710	*10690	9550	*7620	4900	5140	3170			3560	2220	7.69			
	lb	*14790	*14790	*23570	21050	*16800	10800	11330	6990			7850	4890	(25.2)			
-3.0 m (-10.0 ft)	kg	*9990	*9990	*10280	9680	*6960	4930	*4870	3200			*3750	2830	6.64			
	lb	*22020	*22020	*22660	21340	*15340	10870	*10740	7050			*8270	6240	(21.8)			
-4.5 m (-15.0 ft)	kg			*7470	*7470	*4960	*4960										
	lb			*16470	*16470	*10930	*10930										

Note 1. Lifting capacity are based on SAE J1097 and ISO 10567.

2. Lifting capacity of the ROBEX series does not exceed 75% of tipping load with the machine on firm, level ground or 87% of full hydraulic capacity.













3. The load point is a hook located on the back of the bucket.

4. *indicates load limited by hydraulic capacity.

2) R180LCD-9S

(1) 5.1 m (16' 9") boom, 2.6 m (8' 6") arm equipped with 0.76 m³ (SAE heaped) bucket and 600 mm (24") triple grouser shoe and 2900 kg (6390 lb) counterweight.

-  : Rating over-front
-  : Rating over-side or 360 degree

Load point height		Load radius										At max. reach					
		1.5 m (5.0 ft)		3.0 m (10.0 ft)		4.5 m (15.0 ft)		6.0 m (20.0 ft)		7.5 m (25.0 ft)		Capacity		Reach			
														kg	lb	m (ft)	
7.5 m (25.0 ft)	kg																
	lb												*3380	*3380			6.11
													*7450	*7450			(20.0)
6.0 m (20.0 ft)	kg							*3020	*3020				*3360	2800			7.37
	lb							*6660	*6660				*7410	6170			(24.2)
4.5 m (15.0 ft)	kg							*3770	*3770				*3410	2320			8.11
	lb							*8310	*8310				*7520	5110			(26.6)
3.0 m (10.0 ft)	kg			*7910	*7910	*5310	*5310	*4300	3750	*2810	2570	*3500	2090				8.48
	lb			*17440	*17440	*11710	*11710	*9480	8270	*6190	5670	*7720	4610				(27.8)
1.5 m (5.0 ft)	kg			*8120	*8120	*6650	5550	*4920	3570	*3650	2490	3490	2020				8.53
	lb			*17900	*17900	*14660	12240	*10850	7870	*8050	5490	7690	4450				(28.0)
Ground Line	kg			*7910	*7910	*7500	5280	*5380	3430	*3470	2430	3630	2100				8.28
	lb			*17440	*17440	*16530	11640	*11860	7560	*7650	5360	8000	4630				(27.2)
-1.5 m (-5.0 ft)	kg	*6710	*6710	*10690	10060	*7620	5180	*5460	3360			*3810	2360				7.69
	lb	*14790	*14790	*23570	22180	*16800	11420	*12040	7410			*8400	5200				(25.2)
-3.0 m (-10.0 ft)	kg	*9990	*9990	*10280	10180	*6960	5200	*4870	3390			*3750	3000				6.64
	lb	*22020	*22020	*22660	22440	*15340	11460	*10740	7470			*8270	6610				(21.8)
-4.5 m (-15.0 ft)	kg			*7470	*7470	*4960	*4960										
	lb			*16470	*16470	*10930	*10930										

Note 1. Lifting capacity are based on SAE J1097 and ISO 10567.

2. Lifting capacity of the ROBEX series does not exceed 75% of tipping load with the machine on firm, level ground or 87% of full hydraulic capacity.

3. The load point is a hook located on the back of the bucket.













4. *indicates load limited by hydraulic capacity.

3) R180NLC-9S

(1) 5.1 m (16' 9") boom, 2.6 m (8' 6") arm equipped with 0.76 m³ (SAE heaped) bucket and 600 mm (24") triple grouser shoe and 2900 kg (6390 lb) counterweight.

•  : Rating over-front

•  : Rating over-side or 360 degree

Load point height		Load radius										At max. reach		
		1.5 m (5 ft)		3.0 m (10 ft)		4.5 m (15 ft)		6.0 m (20 ft)		7.0 m (25 ft)		Capacity		Reach
														m (ft)
7.5 m (25 ft)	kg											*3380	3290	6.11
	lb											*7450	7250	(20.0)
6.0 m (20 ft)	kg						*3020	*3020				*3360	2320	7.37
	lb						*6660	*6660				*7410	5110	(24.2)
4.5 m (15 ft)	kg						*3770	3250				*3410	1890	8.11
	lb						*8310	7170				*7520	4170	(26.6)
3.0 m (10 ft)	kg			*7910	*7910	*5310	4930	*4300	3100	*2810	2090	3110	1690	8.48
	lb			*17440	*17440	*11710	10870	*9480	6830	*6190	4610	6860	3730	(27.8)
1.5 m (5 ft)	kg			*8120	*8120	*6650	4550	*4920	2930	*3650	2020	3030	1620	8.53
	lb			*17900	*17900	*14660	10030	*10850	6460	*8050	4450	6680	3570	(28.0)
Ground Line	kg			*7910	*7910	*7500	4290	5180	2790	*3470	1960	3150	1680	8.28
	lb			*17440	*17440	*16530	9460	11420	6150	*7650	4320	6940	3700	(27.2)
-1.5 m (-5 ft)	kg	*6710	*6710	*10690	7980	*7620	4190	5110	2720			3540	1900	7.69
	lb	*14790	*14790	*23570	17590	*16800	9240	11270	6000			7800	4190	(25.2)
-3.0 m (-10 ft)	kg	*9990	*9990	*10280	8100	*6960	4210	*4870	2750			*3750	2440	6.64
	lb	*22020	*22020	*22660	17860	*15340	9280	*10740	6060			*8270	5380	(21.8)
-1.5 m (-15 ft)	kg			*7470	*7470	*4960	4390							
	lb			*16470	*16470	*10930	9680							

Note 1. Lifting capacity are based on SAE J1097 and ISO 10567.

2. Lifting capacity of the ROBEX series does not exceed 75% of tipping load with the machine on firm, level ground or 87% of full hydraulic capacity.

3. The load point is a hook located on the back of the bucket.

4. *indicates load limited by hydraulic capacity.

6. BUCKET SELECTION GUIDE

1) GENERAL BUCKET

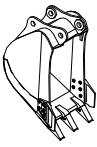
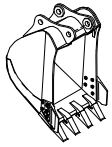
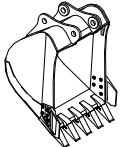
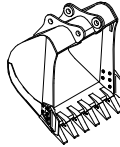
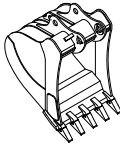
				
0.39 m ³ SAE heaped bucket	0.50 m ³ SAE heaped bucket	0.64, ※ 0.76 m ³ SAE heaped bucket	0.89, 1.05 m ³ SAE heaped bucket	◆ 0.69 m ³ SAE heaped bucket

Capacity		Width		Weight	Recommendation				
					5.1 m (16' 9") Mono boom			5.1 m (16' 9") Hyd adjustable boom	
SAE heaped	CECE heaped	Without side cutter	With side cutter		2.2 m arm (7' 3")	2.6 m arm (8' 6")	3.1 m arm (10' 2")	2.2 m arm (7' 3")	2.6 m arm (8' 6")
0.39 m ³ (0.51 yd ³)	0.34 m ³ (0.44 yd ³)	620 mm (24.4")	740 mm (29.1")	410 kg (900 lb)					
0.50 m ³ (0.65 yd ³)	0.44 m ³ (0.58 yd ³)	760 mm (29.9")	880 mm (34.6")	470 kg (1040 lb)					
0.64 m ³ (0.84 yd ³)	0.55 m ³ (0.72 yd ³)	920 mm (36.2")	1040 mm (40.9")	510 kg (1120 lb)					
※ 0.76 m ³ (0.99 yd ³)	0.65 m ³ (0.85 yd ³)	1060 mm (41.7")	1180 mm (46.5")	570 kg (1260 lb)					
0.89 m ³ (1.16 yd ³)	0.77 m ³ (1.01 yd ³)	1220 mm (48.0")	1340 mm (52.8")	610 kg (1340 lb)					
1.05 m ³ (1.37 yd ³)	0.90 m ³ (1.18 yd ³)	1400 mm (55.1")	1520 mm (59.8")	680 kg (1500 lb)					
◆ 0.69 m ³ (0.90 yd ³)	0.62 m ³ (0.81 yd ³)	990 mm (39.0")	-	700 kg (1540 lb)					

◆ : Heavy duty bucket

※ : Standard

 Applicable for materials with density of 2000 kg/m³ (3370 lb/yd³) or less

 Applicable for materials with density of 1600 kg/m³ (2700 lb/yd³) or less

 Applicable for materials with density of 1100 kg/m³ (1850 lb/yd³) or less

7. UNDERCARRIAGE

1) TRACKS

X-leg type center frame is integrally welded with reinforced box-section track frames. The design includes dry tracks, lubricated rollers, idlers, sprockets, hydraulic track adjusters with shock absorbing springs and assembled track-type tractor shoes with triple grousers.

2) TYPES OF SHOES

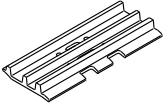
Model	Shapes		Triple grouser			
						
R180LC-9S	Shoe width	mm (in)	500 (20)	600 (24)	700 (28)	800 (32)
	Operating weight	kg (lb)	18350 (40450)	18600 (41010)	18850 (41560)	19100 (42110)
	Ground pressure	kgf/cm ² (psi)	0.51 (7.25)	0.43 (6.11)	0.37 (5.26)	0.33 (4.69)
	Overall width	mm (ft-in)	2750 (9' 0")	2850 (9' 4")	2950 (9' 8")	3050 (10' 0")
R180LCD-9S	Shoe width	mm (in)	500 (20)	600 (24)	700 (28)	800 (32)
	Operating weight	kg (lb)	19350 (42660)	19600 (43210)	19850 (43760)	20100 (44310)
	Ground pressure	kgf/cm ² (psi)	0.54 (7.54)	0.45 (6.40)	0.39 (5.55)	0.35 (4.98)
	Overall width	mm (ft-in)	2750 (9' 0")	2850 (9' 4")	2950 (9' 8")	3050 (10' 0")

3) NUMBER OF ROLLERS AND SHOES ON EACH SIDE

Item	Quantity
Carrier rollers	2 EA
Track rollers	8 EA
Track shoes	51 EA

4) SELECTION OF TRACK SHOE

Suitable track shoes should be selected according to operating conditions.

Method of selecting shoes

Confirm the category from the list of applications in **table 2**, then use **table 1** to select the shoe.

Wide shoes (Categories B and C) have limitations on applications. Before using wide shoes, check the precautions, then investigate and study the operating conditions to confirm if these shoes are suitable.

Select the narrowest shoe possible to meet the required flotation and ground pressure.

Application of wider shoes than recommendations will cause unexpected problem such as bending of shoes, crack of link, breakage of pin, loosening of shoe bolts and the other various problems.

※ **Table 1**

Track shoe	Specification	Category
500 mm triple grouser	Option	A
600 mm triple grouser	Standard	A
700 mm triple grouser	Option	B
800 mm triple grouser	Option	C

※ **Table 2**

Category	Applications	Applications
A	Rocky ground, river beds, normal soil	<ul style="list-style-type: none"> Travel at low speed on rough ground with large obstacles such as boulders or fallen trees
B	Normal soil, soft ground	<ul style="list-style-type: none"> These shoes cannot be used on rough ground with large obstacles such as boulders or fallen trees Travel at high speed only on flat ground Travel slowly at low speed if it is impossible to avoid going over obstacles
C	Extremely soft ground (swampy ground)	<ul style="list-style-type: none"> Use the shoes only in the conditions that the machine sinks and it is impossible to use the shoes of category A or B These shoes cannot be used on rough ground with large obstacles such as boulders or fallen trees Travel at high speed only on flat ground Travel slowly at low speed if it is impossible to avoid going over obstacles

8. SPECIFICATIONS FOR MAJOR COMPONENTS

1) ENGINE

Item	Specification
Model	Mitsubishi S6S-DT
Type	4-cycle turbocharged charge air cooled diesel engine
Cooling method	Water cooling
Number of cylinders and arrangement	6 cylinders, in-line
Firing order	1-5-3-6-2-4
Combustion chamber type	Direct injection type
Cylinder bore × stroke	94 × 120 mm (3.70" × 4.72")
Piston displacement	4996 cc (305 cu in)
Compression ratio	19.5 : 1
Rated gross horse power (SAE J1995)	126Hp (94 kW) at 2100 rpm
Maximum torque	42.5 kgf · m (307 lbf · ft) at 1500 rpm
Engine oil quantity	16.5 l (4.4 U.S. gal)
Dry weight	355 kg (780 lb)
High idling speed	2200 ± 50 rpm
Low idling speed	950 ± 100 rpm
Rated fuel consumption	169.3 g/Hp · hr at 2100 rpm
Starting motor	24 V-5.0 kW
Alternator	24 V-50 A
Battery	2 × 12 V × 100 Ah

2) MAIN PUMP

Item	Specification
Type	Variable displacement tandem axis piston pumps
Capacity	2 × 80 cc/rev
Maximum pressure	350 kgf/cm ² (4980 psi) [380 kgf/cm ² (5400 psi)]
Rated oil flow	2 × 160 l /min (42.3 U.S. gpm / 35.2 U.K. gpm)
Rated speed	2100 rpm

[] : Power boost

3) GEAR PUMP

Item	Specification
Type	Fixed displacement gear pump single stage
Capacity	15cc/rev
Maximum pressure	40 kgf/cm ² (570 psi)
Rated oil flow	30 l /min (7.9 U.S. gpm / 6.6 U.K. gpm)

4) MAIN CONTROL VALVE

Item	Specification
Type	11 spools two-block
Operating method	Hydraulic pilot system
Main relief valve pressure	350 kgf/cm ² (4980 psi)[380 kgf/cm ² (5400 psi)]
Overload relief valve pressure	400 kgf/cm ² (5690 psi)

[] : Power boost

5) SWING MOTOR

Item	Specification
Type	Two fixed displacement axial piston motor
Capacity	117.8 cc/rev
Relief pressure	285 kgf/cm ² (4053 psi)
Braking system	Automatic, spring applied hydraulic released
Braking torque	59 kgf · m (427 lbf · ft)
Brake release pressure	33~50 kgf/cm ² (469~711 psi)
Reduction gear type	2 - stage planetary

6) TRAVEL MOTOR

Item	Specification
Type	Variable displacement axial piston motor
Relief pressure	350 kgf/cm ² (4980 psi)
Reduction gear type	Planetary & differential type
Braking system	Automatic, spring applied hydraulic released
Brake release pressure	11 kgf/cm ² (156 psi)
Braking torque	49.3 kgf · m (357 lbf · ft)

7) CYLINDER

Item		Specification
Boom cylinder	Bore dia × Rod dia × Stroke	∅ 115 × ∅ 80 × 1090 mm
	Cushion	Extend only
Arm cylinder	Bore dia × Rod dia × Stroke	∅ 120 × ∅ 85 × 1355 mm
	Cushion	Extend and retract
Bucket cylinder	Bore dia × Rod dia × Stroke	∅ 110 × ∅ 75 × 995 mm
	Cushion	Extend only
Dozer cylinder	Bore dia × Rod dia × Stroke	∅ 110 × ∅ 85 × 320 mm
	Cushion	Extend only
Boom cylinder (adjust boom)	Bore dia × Rod dia × Stroke	∅ 115 × ∅ 80 × 960 mm
	Cushion	Extend only
Adjust cylinder	Bore dia × Rod dia × Stroke	∅ 160 × ∅ 95 × 650 mm
	Cushion	Extended only

※ Discoloration of cylinder rod can occur when the friction reduction additive of lubrication oil spreads on the rod surface.

※ Discoloration does not cause any harmful effect on the cylinder performance.

8) SHOE

Item		Width	Ground pressure	Link quantity	Overall width
R180LC-9S	Option	500 mm (20")	0.51 kgf/cm ² (7.25 psi)	51	2750 mm (9' 0")
	Standard	600 mm (24")	0.43 kgf/cm ² (6.11 psi)	51	2850 mm (9' 4")
	Option	700 mm (28")	0.37 kgf/cm ² (5.26 psi)	51	2950 mm (9' 8")
	Option	800 mm (32")	0.33 kgf/cm ² (4.69 psi)	51	3050 mm (10' 0")

9) BUCKET

Item	Capacity		Tooth quantity	Width	
	SAE heaped	CECE heaped		Without side cutter	With side cutter
R180LC-9S	0.76 m ³ (0.99 yd ³)	0.65 m ³ (0.85 yd ³)	5	1060 mm (41.7")	1180 mm (46.5")
	0.39 m ³ (0.51 yd ³)	0.34 m ³ (0.44 yd ³)	3	620 mm (24.4")	740 mm (29.1")
	0.50 m ³ (0.65 yd ³)	0.44 m ³ (0.58 yd ³)	4	760 mm (29.9")	880 mm (34.6")
	0.64 m ³ (0.84 yd ³)	0.55 m ³ (0.72 yd ³)	5	920 mm (36.2")	1040 mm (40.9")
	0.89 m ³ (1.16 yd ³)	0.77 m ³ (1.01 yd ³)	6	1220 mm (48.0")	1340 mm (52.8")
	1.05 m ³ (1.37 yd ³)	0.90 m ³ (1.18 yd ³)	6	1400 mm (55.1")	1520 mm (59.8")
	◆ 0.69 m ³ (0.90 yd ³)	0.62 m ³ (0.81 yd ³)	5	990 mm (39.0")	-

◆ : Heavy duty bucket

9. RECOMMENDED OILS

Use only oils listed below. Do not mix different brand oil.

Please use HYUNDAI genuine oil and grease.

Service point	Kind of fluid	Capacity ℓ (U.S. gal)	Ambient temperature °C (°F)						
			-50 (-58)	-30 (-22)	-20 (-4)	-10 (14)	0 (32)	10 (50)	20 (68)
Engine oil pan	Engine oil	16.5 (4.4)	★SAE 5W-40						
			SAE 30						
			SAE 10W						
			SAE 10W-30						
			SAE 15W-40						
Swing drive	Gear oil	5.0 (1.3)	★SAE 75W-90						
Final drive		5.8×2 (1.53×2)	SAE 80W-90						
Hydraulic tank	Hydraulic oil	Tank: 160 (42.3) System: 270 (71.3)	★ISO VG 15						
			ISO VG 32						
			ISO VG 46						
			ISO VG 68						
Fuel tank	Diesel fuel	270 (71.3)	★ASTM D975 NO.1						
			ASTM D975 NO.2						
Fitting (grease nipple)	Grease	As required	★NLGI NO.1						
			NLGI NO.2						
Radiator (reservoir tank)	Mixture of antifreeze and soft water★ ¹	17.5 (4.6)	Ethylene glycol base permanent type (50 : 50)						
			★ Ethylene glycol base permanent type (60 : 40)						

SAE : Society of Automotive Engineers

API : American Petroleum Institute

ISO : International Organization for Standardization

NLGI : National Lubricating Grease Institute

ASTM : American Society of Testing and Material

★¹ : Soft water

City water or distilled water

★ : Cold region

Russia, CIS, Mongolia