

# GROUP 2 ENGINE SYSTEM

## 1. ENGINE AND ACCESSORIES MOUNTING

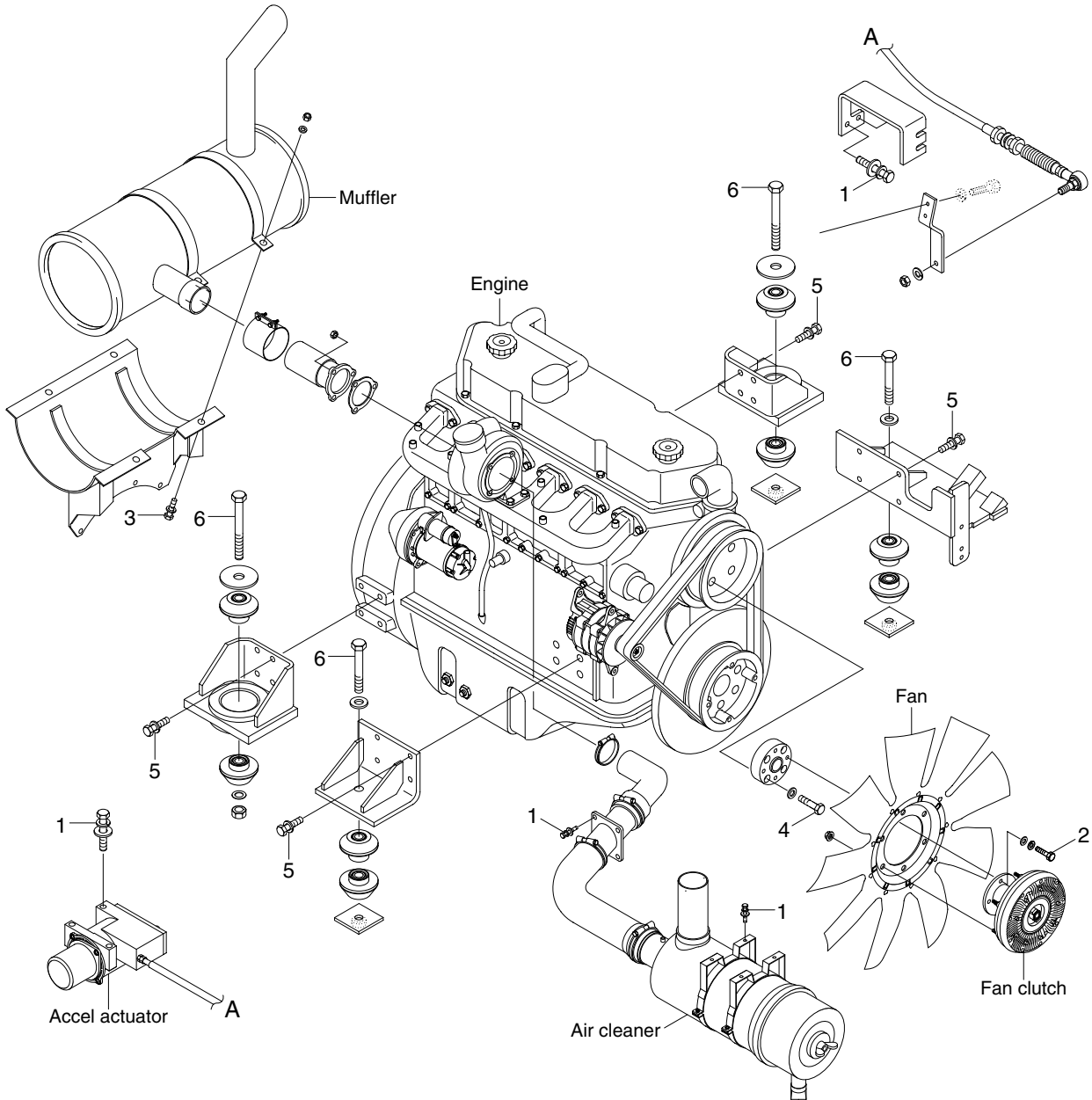

1609S9CM01

### · Tightening torque

Item	Size	kgf · m	lbf · ft
1	M 8×1.25	2.5±0.5	18.1±3.6
2	M10×1.5	4.4±0.5	31.8±3.6
3	M10×1.5	6.9±1.4	49.9±10.1

Item	Size	kgf · m	lbf · ft
4	M10×1.25	7.4±1.5	53.5±10.8
5	M12×1.75	10.0±1.0	72.3±7.2
6	M20×2.5	55±3.5	398±25.3

## 2. COOLING SYSTEM AND FUEL TANK MOUNTING

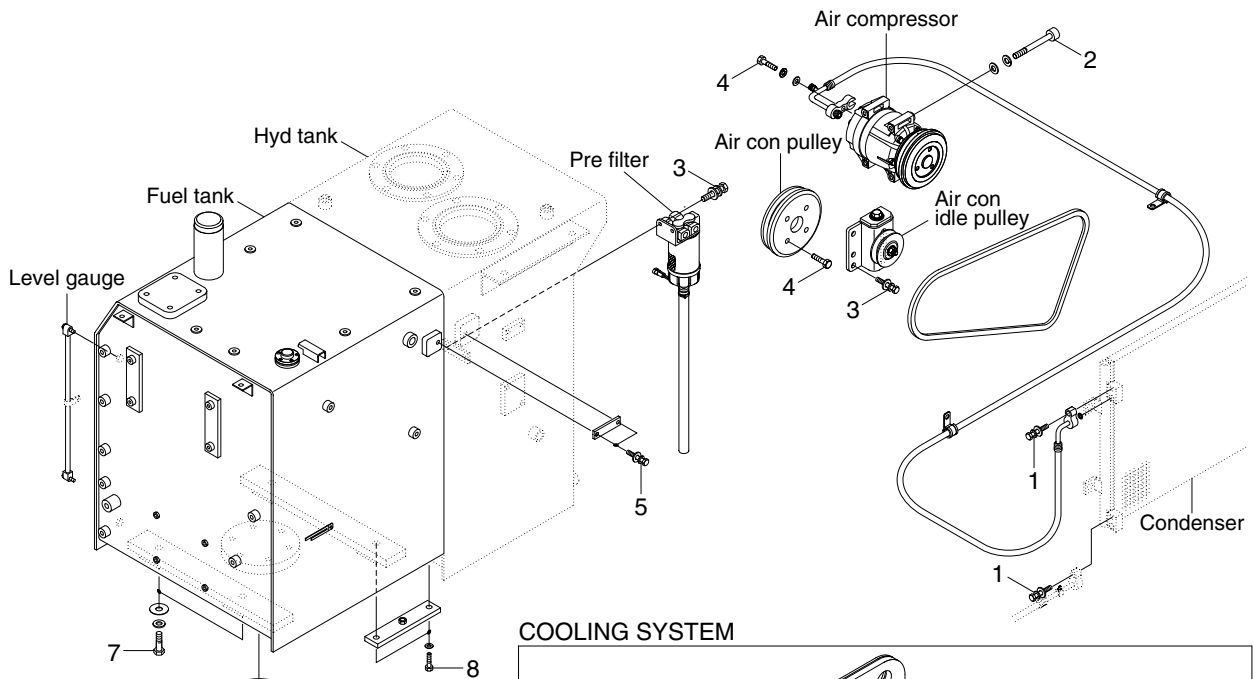

### COOLING SYSTEM

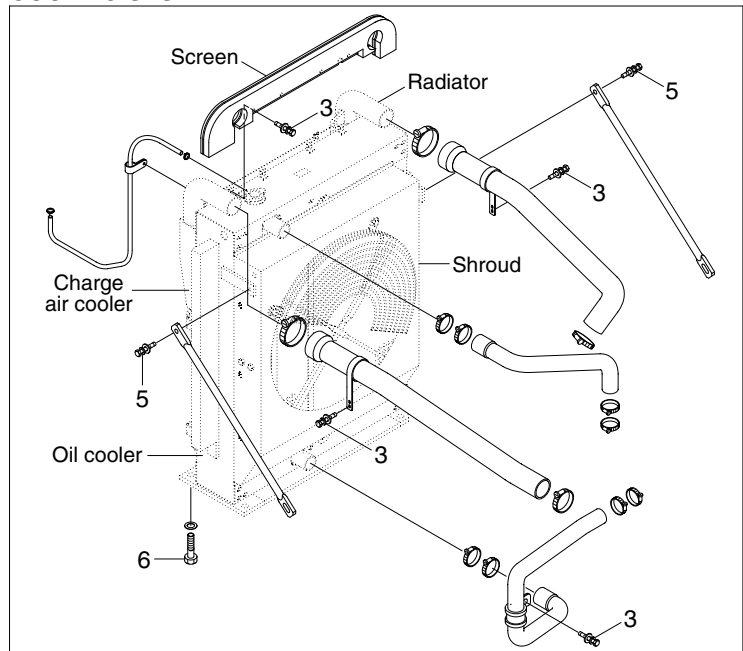

1609S9CM02

### ·Tightening torque

Item	Size	kgf·m	lbf·ft
1	M 8×1.25	2.5±0.5	18.1±3.6
2	M 8×1.25	4.05±0.8	29.3±5.8
3	M10×1.5	6.9±1.4	49.9±10.1
4	M10×1.5	8.3±1.7	60±12.3
5	M12×1.75	12.8±3.0	92.6±21.7

Item	Size	kgf·m	lbf·ft
6	M16×2.0	29.7±4.5	215±32.5
7	M20×2.5	46±5.1	333±36.9
8	M20×2.5	57.9±8.7	419±62.9
9	-	2.3±0.6	16.6±4.3
-	-	-	-