

GROUP 3 ELECTRIC SYSTEM

1. ELECTRIC COMPONENTS MOUNTING 1

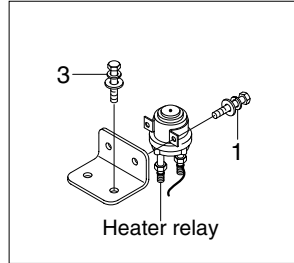

DETAIL A

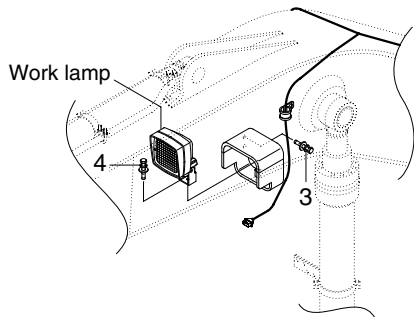
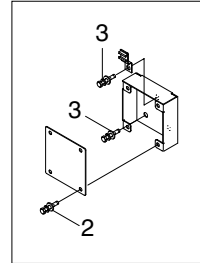

DETAIL B

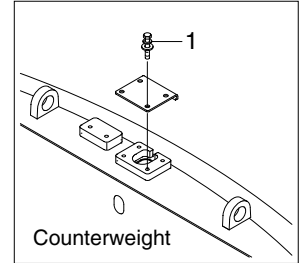

DETAIL C

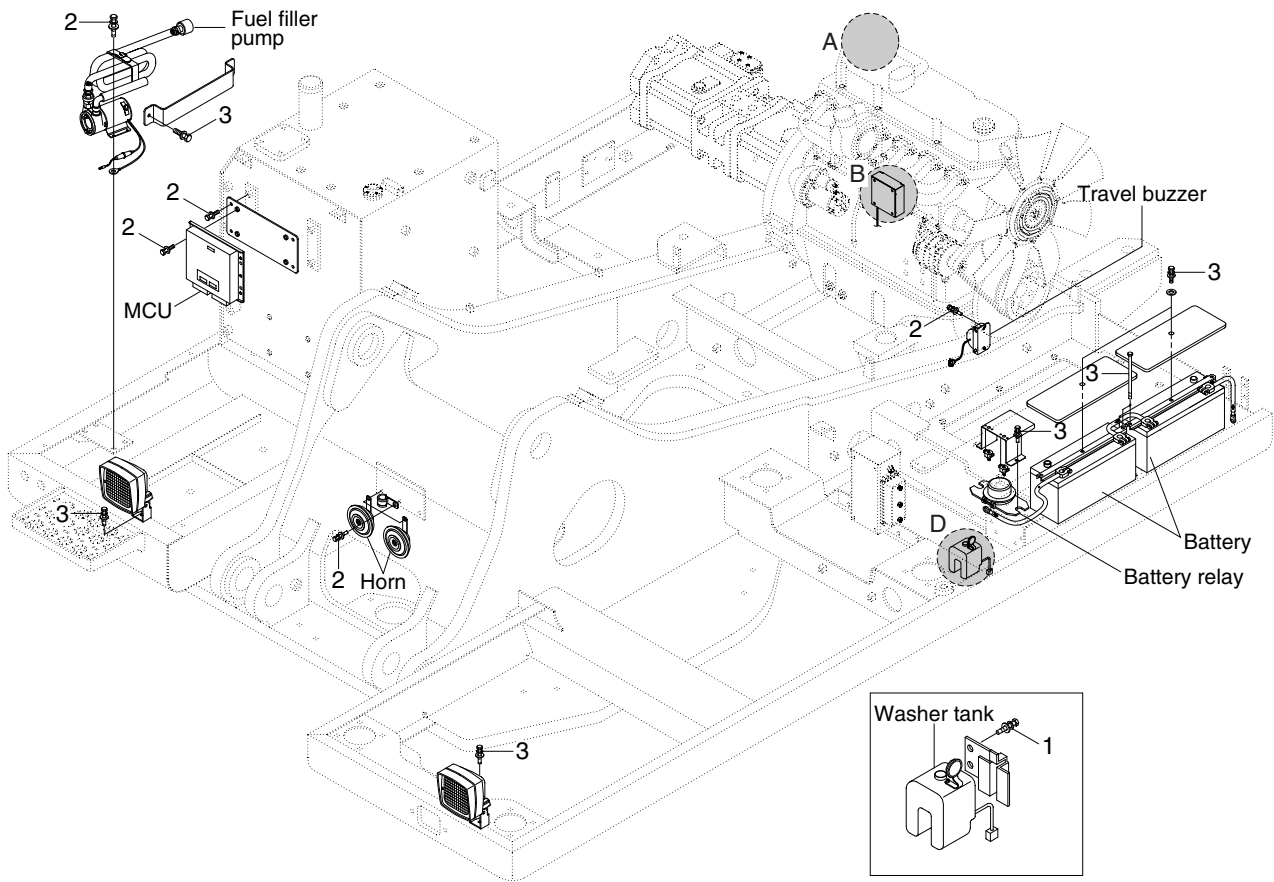

1609S9CM03

· Tightening torque

| Item | Size | kgf · m | lbf · ft |
|------|------------|------------|------------|
| 1 | M 6 × 1.0 | 1.05 ± 0.2 | 7.6 ± 1.45 |
| 2 | M 8 × 1.25 | 2.5 ± 0.5 | 18.1 ± 3.6 |

| Item | Size | kgf · m | lbf · ft |
|------|-------------|------------|-------------|
| 3 | M 10 × 1.5 | 6.9 ± 1.4 | 49.9 ± 10.1 |
| 4 | M 12 × 1.75 | 12.8 ± 3.0 | 92.6 ± 21.7 |

2. ELECTRIC COMPONENTS MOUNTING 2

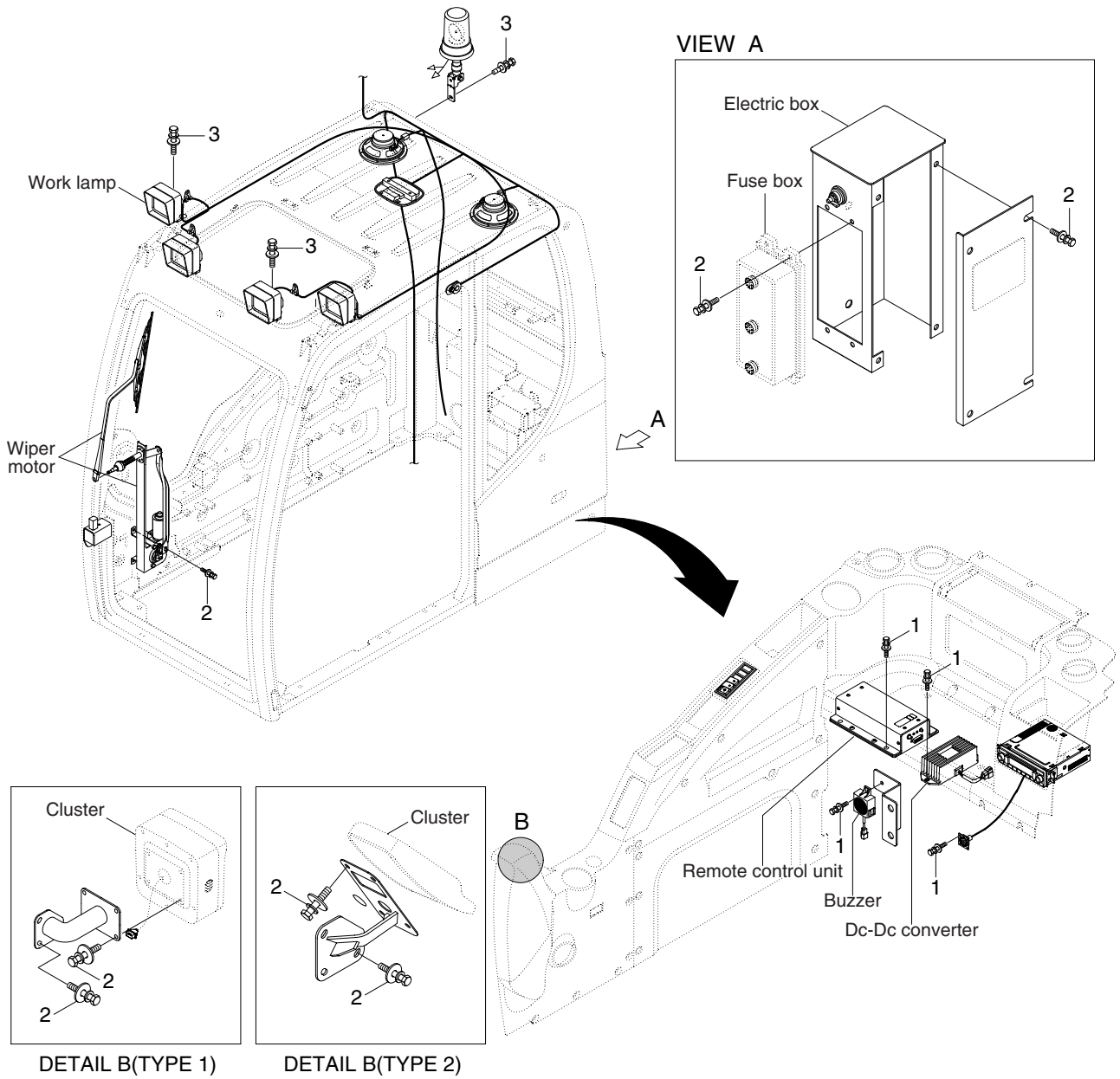

1609S9CM04

· Tightening torque

| Item | Size | kgf · m | lbf · ft |
|------|----------|----------|----------|
| 1 | M 6×1.0 | 1.05±0.2 | 7.6±1.45 |
| 2 | M 8×1.25 | 2.5±0.5 | 18.1±3.6 |

| Item | Size | kgf · m | lbf · ft |
|------|---------|---------|-----------|
| 3 | M10×1.5 | 6.9±1.4 | 49.9±10.1 |