

GROUP 3 TRACK AND WORK EQUIPMENT

1. TRACK

1) TRACK ROLLER

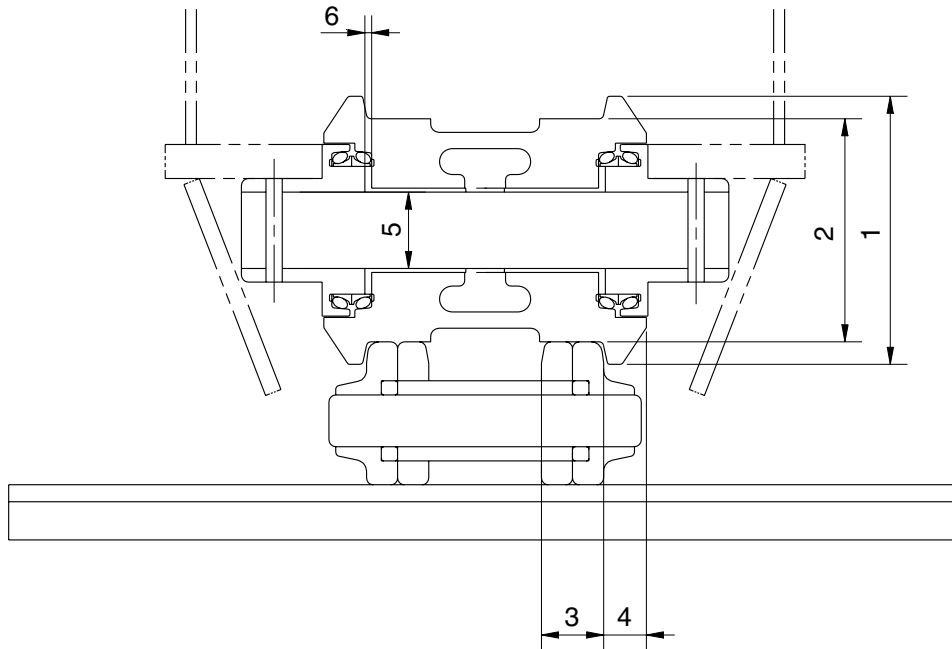

21037MS01

Unit : mm

| No. | Check item | Criteria | | | | Remedy |
|-----|--------------------------------------|--|---|-------------------------------------|------------------------|--------------------|
| | | Standard size | | Repair limit | | |
| 1 | Outside diameter of flange | ø 200 | | - | | Rebuild or replace |
| 2 | Outside diameter of tread | ø 160 | | ø 148 | | |
| 3 | Width of tread | 48 | | 54 | | |
| 4 | Width of flange | 21.5 | | - | | |
| 5 | Clearance between shaft and bushing | Standard size & tolerance | | Standard clearance 0.39 to 0.476 | Clearance limit 2.0 | Replace bushing |
| | | Shaft ø 70 $\begin{matrix} -0.29 \\ -0.33 \end{matrix}$ | Hole ø 70.1 $\begin{matrix} +0.46 \\ 0 \end{matrix}$ | | | |
| 6 | Side clearance of roller (both side) | Standard clearance | | Clearance limit | | Replace |
| | | 0.2 to 1.2 | | 2.0 | | |

2) CARRIER ROLLER

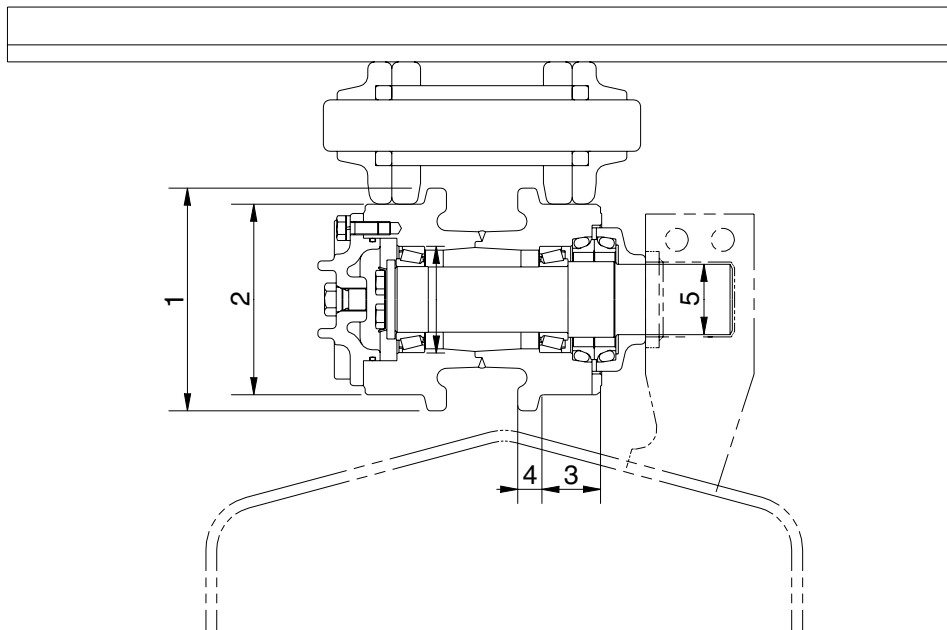

16077MSS02

Unit : mm

| No. | Check item | Criteria | | | | Remedy |
|-----|-------------------------------------|---------------------------|-------------------|--------------------|-----------------|--------------------|
| | | Standard size | | Repair limit | | |
| 1 | Outside diameter of flange | ø 169 | | ø 155 | | Rebuild or replace |
| 2 | Outside diameter of tread | ø 144 | | ø 134 | | |
| 3 | Width of tread | 44 | | 49 | | |
| 4 | Width of flange | 17 | | - | | |
| 5 | Clearance between shaft and bushing | Standard size & Tolerance | | Standard clearance | Clearance limit | Replace bushing |
| | | Shaft | Hole | | | |
| | | ø 55 -0.05 -0.1 | ø 55 +0.3 +0.1 | 0.15 to 0.48 | 1.2 | |

3) IDLER

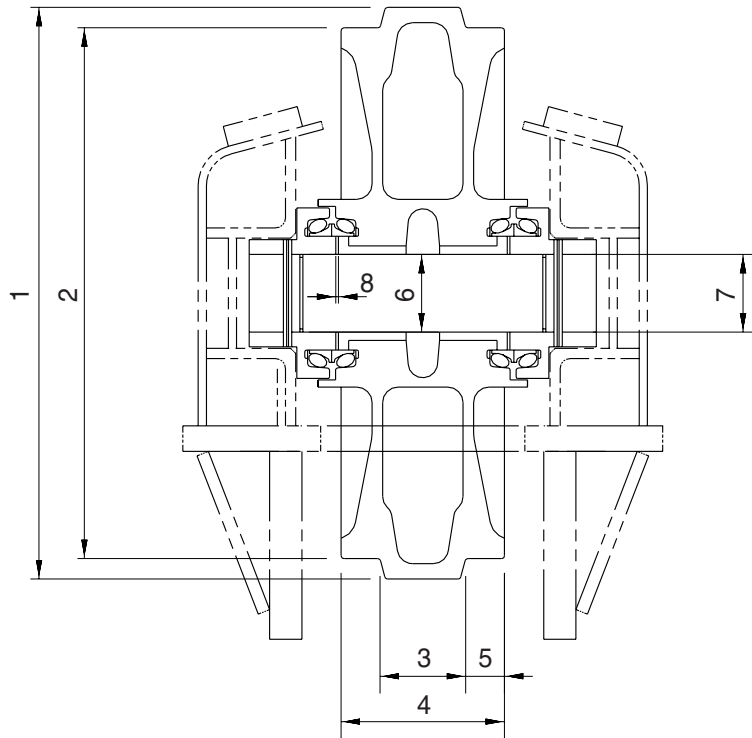

21037MS03

Unit : mm

| No. | Check item | Criteria | | | | Remedy |
|-----|-------------------------------------|--|---|--------------------|-----------------|--------------------|
| | | Standard size | | Repair limit | | |
| 1 | Outside diameter of flange | ø 560 | | - | | Rebuild or replace |
| 2 | Outside diameter of tread | ø 520 | | ø 510 | | |
| 3 | Width of protrusion | 84 | | - | | |
| 4 | Total width | 160 | | - | | |
| 5 | Width of tread | 38 | | 43 | | |
| 6 | Clearance between shaft and bushing | Standard size & Tolerance | | Standard clearance | Clearance limit | Replace bushing |
| | | Shaft | Hole | | | |
| | | ø 75 $\begin{matrix} 0 \\ -0.03 \end{matrix}$ | ø 75.35 $\begin{matrix} +0.05 \\ 0 \end{matrix}$ | 0.35 to 0.43 | 2.0 | |
| 7 | Clearance between shaft and support | ø 750 $\begin{matrix} 0 \\ -0.03 \end{matrix}$ | ø 75 $\begin{matrix} +0.07 \\ +0.03 \end{matrix}$ | 0.03 to 0.1 | 1.2 | Replace |
| 8 | Side clearance of idler (both side) | Standard clearance | | Clearance limit | | Replace bushing |
| | | 0.25 to 1.2 | | 2.0 | | |

4) TRACK

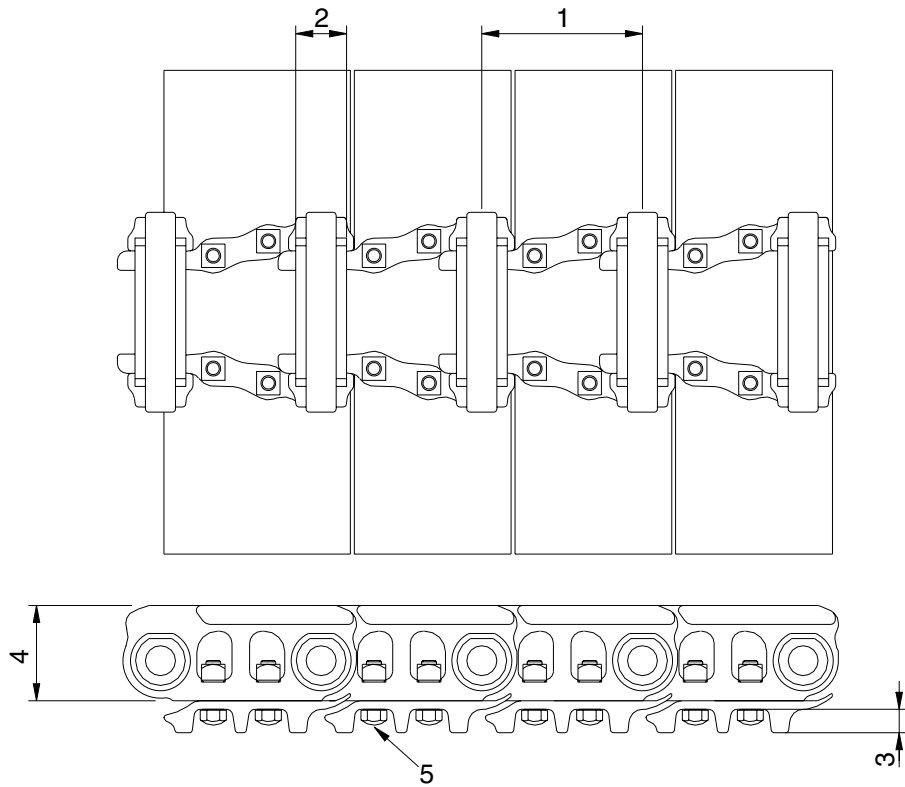

32077MS04

Unit : mm

| No. | Check item | Criteria | | Remedy |
|-----|-----------------------------|--|--------------|--------------------|
| | | Standard size | Repair limit | |
| 1 | Link pitch | 171.45 | 178.95 | Turn or replace |
| | | 171.45 | 178.95 | |
| 2 | Outside diameter of bushing | ∅ 54 | ∅ 46 | Rebuild or replace |
| 3 | Height of grouser | 25 | 16 | |
| 4 | Height of link | 101.6 | 93.6 | |
| 5 | Tightening torque | Initial tightening torque : 40 ± 4 kgf · m | | Retighten |

5) TRACK FRAME AND RECOIL SPRING

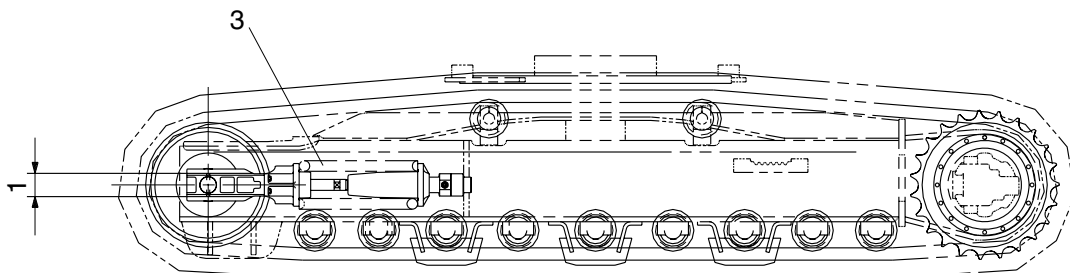
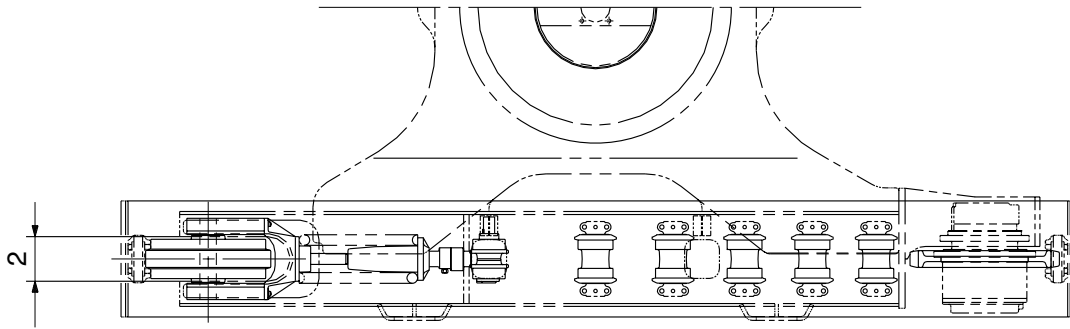

21037MS05

Unit : mm

| No. | Check item | Criteria | | | | Remedy | |
|-----|---------------------------------|---------------|---------------------|-------------------|--------------|--------------------|---------|
| | | | Standard size | Tolerance | Repair limit | | |
| 1 | Vertical width of idler guide | Track frame | 113 | +2 0 | 117 | Rebuild or replace | |
| | | Idler support | 110 | -0.5 -1.0 | 106 | | |
| 2 | Horizontal width of idler guide | Track frame | 272 | +2 0 | 276 | | |
| | | Idler support | 270 | - | 267 | | |
| 3 | Recoil spring | Standard size | | | Repair limit | | Replace |
| | | Free length | Installation length | Installation load | Free length | Installation load | |
| | | ∅ 225 × 552 | 420 | 11,908kg | - | 9,526kg | |

2. WORK EQUIPMENT

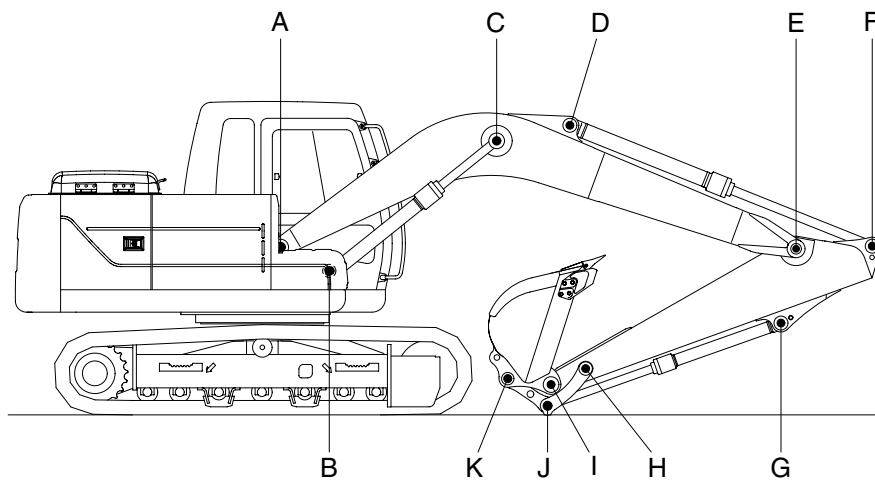

16097MS01

Unit : mm

| Mark | Measuring point (Pin and Bushing) | Normal value | Pin | | Bushing | | Remedy & Remark |
|------|--------------------------------------|-----------------|-----------------------------|-----------------|-----------------------------|-----------------|-----------------------|
| | | | Recomm. service limit | Limit of use | Recomm. service limit | Limit of use | |
| A | Boom Rear | 75 | 74 | 73.5 | 75.5 | 76 | Replace |
| B | Boom Cylinder Head | 70 | 69 | 68.5 | 70.5 | 71 | " |
| C | Boom Cylinder Rod | 75 | 74 | 73.5 | 75.5 | 76 | " |
| D | Arm Cylinder Head | 70 | 69 | 68.5 | 70.5 | 71 | " |
| E | Boom Front | 75 | 74 | 73.5 | 75.5 | 76 | " |
| F | Arm Cylinder Rod | 70 | 69 | 68.5 | 70.5 | 71 | " |
| G | Bucket Cylinder Head | 70 | 69 | 68.5 | 70.5 | 71 | " |
| H | Arm Link | 70 | 69 | 68.5 | 70.5 | 71 | " |
| I | Bucket and Arm Link | 70 | 69 | 68.5 | 70.5 | 71 | " |
| J | Bucket Cylinder Rod | 70 | 69 | 68.5 | 70.5 | 71 | " |
| K | Bucket Link | 70 | 69 | 68.5 | 70.5 | 71 | " |