

## GROUP 4 SINGLE OPERATION

### 1. BOOM UP OPERATION

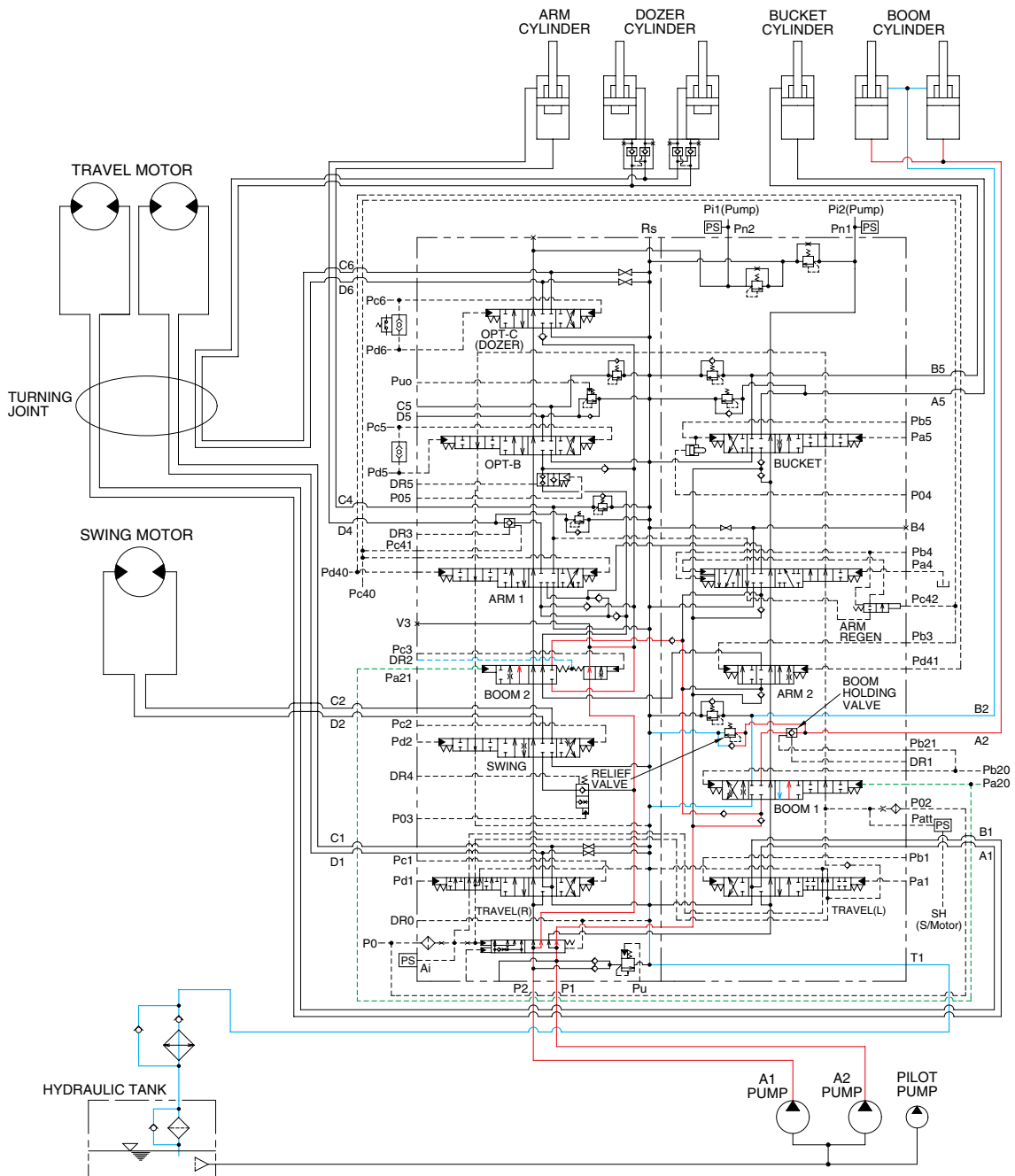

1609A3HC10

When the right control lever is pulled back, the boom spools in the main control valve are moved to the up position by the pilot oil pressure from the remote control valve.

The oil from the A1 and A2 pump flows into the main control valve and then goes to the large chamber of boom cylinders. At the same time, the oil from the small chamber of boom cylinders returns to the hydraulic oil tank through the boom spool in the main control valve. When this happens, the boom goes up. The excessive pressure in the boom cylinder head side is prevented by relief valve. When the boom is up and the control lever is returned to neutral position, the circuit for the holding pressure at the head side of the boom cylinder is closed by the boom holding valve. This prevents the hydraulic drift of boom cylinder.

## 2. BOOM DOWN OPERATION

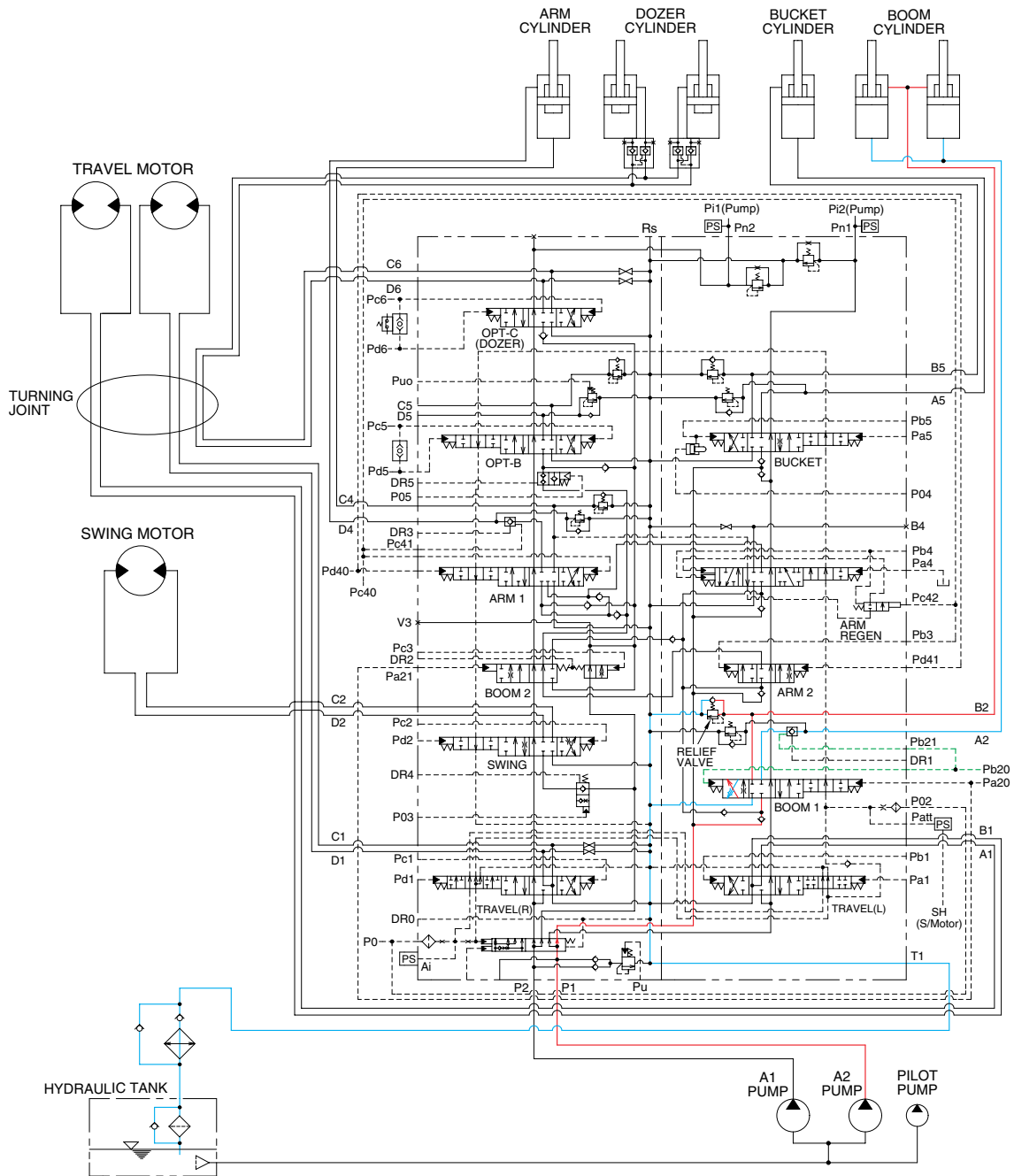

1609A3HC11

When the right control lever is pushed forward, the boom 1 spool in the main control valve is moved to the down position by the pilot oil pressure from the remote control valve.

The oil from the A2 pump flows into the main control valve and then goes to the small chamber of boom cylinders. At the same time, the oil from the large chamber of boom cylinders returns to the hydraulic tank through the boom 1 spool in the main control valve.

When the down speed of boom is faster, the oil returned from the large chamber of boom cylinder combines with the oil from the A2 pump, and flows into the small chamber of the cylinder.

This prevents cylinder cavitation by the negative pressure when the A2 pump flow can not match the boom down speed. And the excessive pressure in the boom cylinder rod side is prevented by the relief valve.

### 3. ARM IN OPERATION

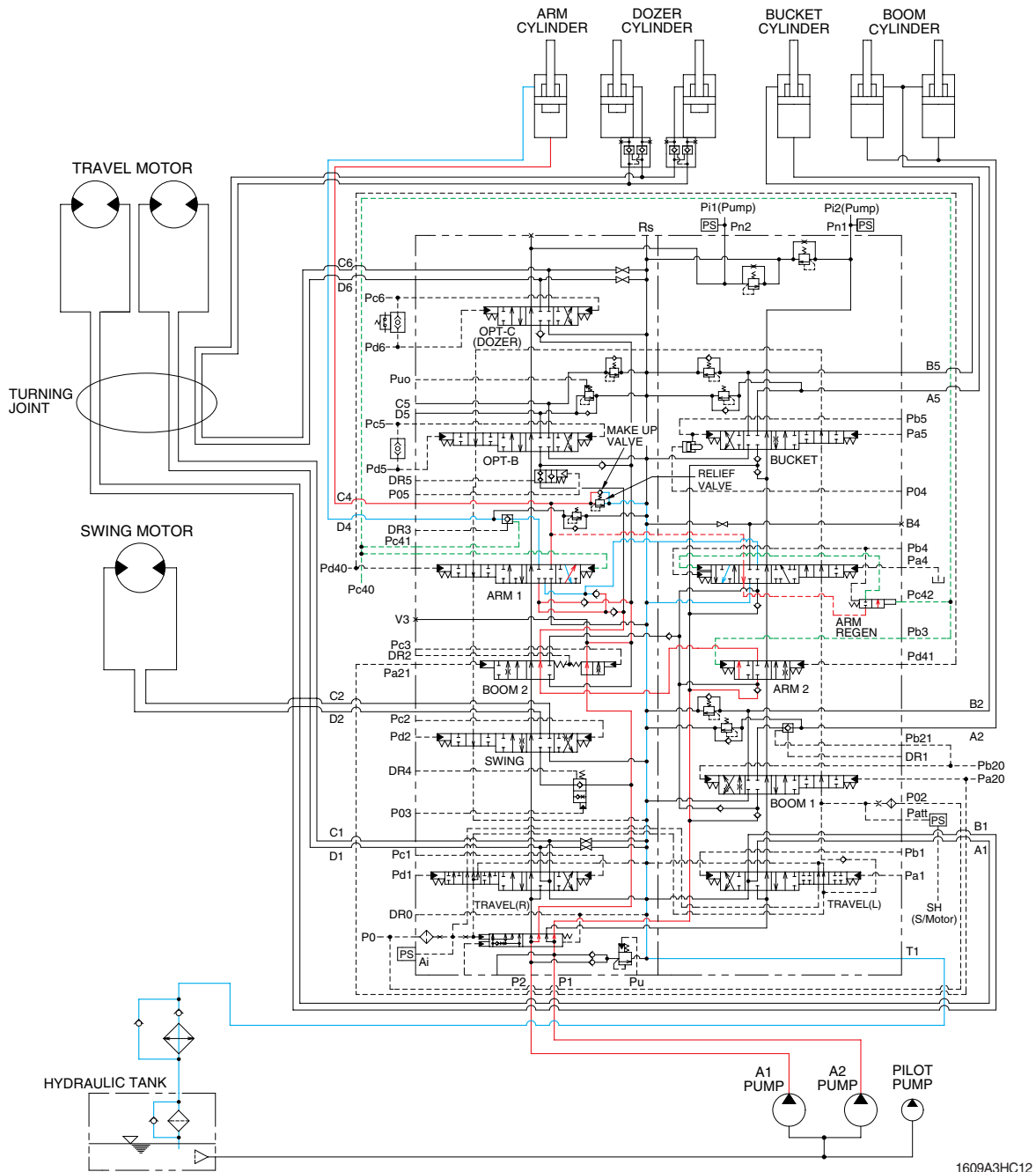

1609A3HC12

When the left control lever is pulled back, the arm spools in the main control valve are moved to the arm in position by the pilot oil pressure from the remote control valve.

The oil from the A1 and A2 pump flows into the main control valve and then goes to the large chamber of arm cylinder.

At the same time, the oil from small chamber of arm cylinder returns to the hydraulic oil tank through the arm spool in the main control valve. When this happens, the arm rolls in.

The excessive pressure in the arm cylinder head side is prevented by relief valve.

The cavitation which will happen to the head side of the arm cylinder is also prevented by the make-up valve in the main control valve.

## 4. ARM OUT OPERATION

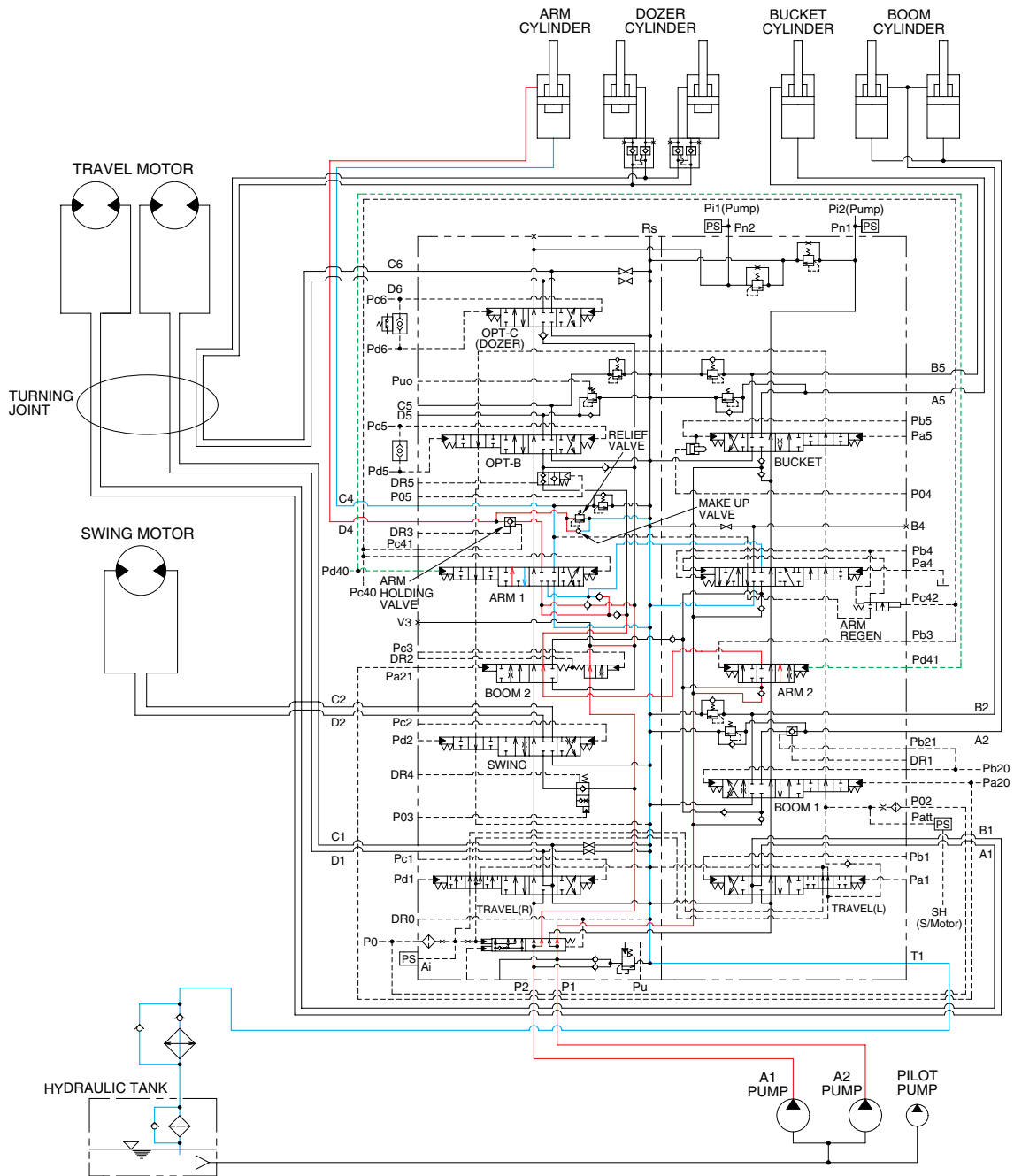

1609A3HC13

When the left control lever is pushed forward, the arm spools in the main control valve are moved to the arm out position by the pilot oil pressure from the remote control valve.

The oil from the A1 and A2 pump flows into the main control valve and then goes to the small chamber of arm cylinder. At the same time, the oil from the large chamber of arm cylinder returns to the hydraulic oil tank through the arm spool in the main control valve. When this happens, the arm rolls out. The cavitation which will happen to the rod side of the arm cylinder is also prevented by the make-up valve in the main control valve. When the arm is roll out and the control lever is returned to neutral position, the circuit for the holding pressure at the rod side of the arm cylinder is closed by the arm holding valve. This prevent the hydraulic drift of arm cylinder.

## 5. BUCKET IN OPERATION

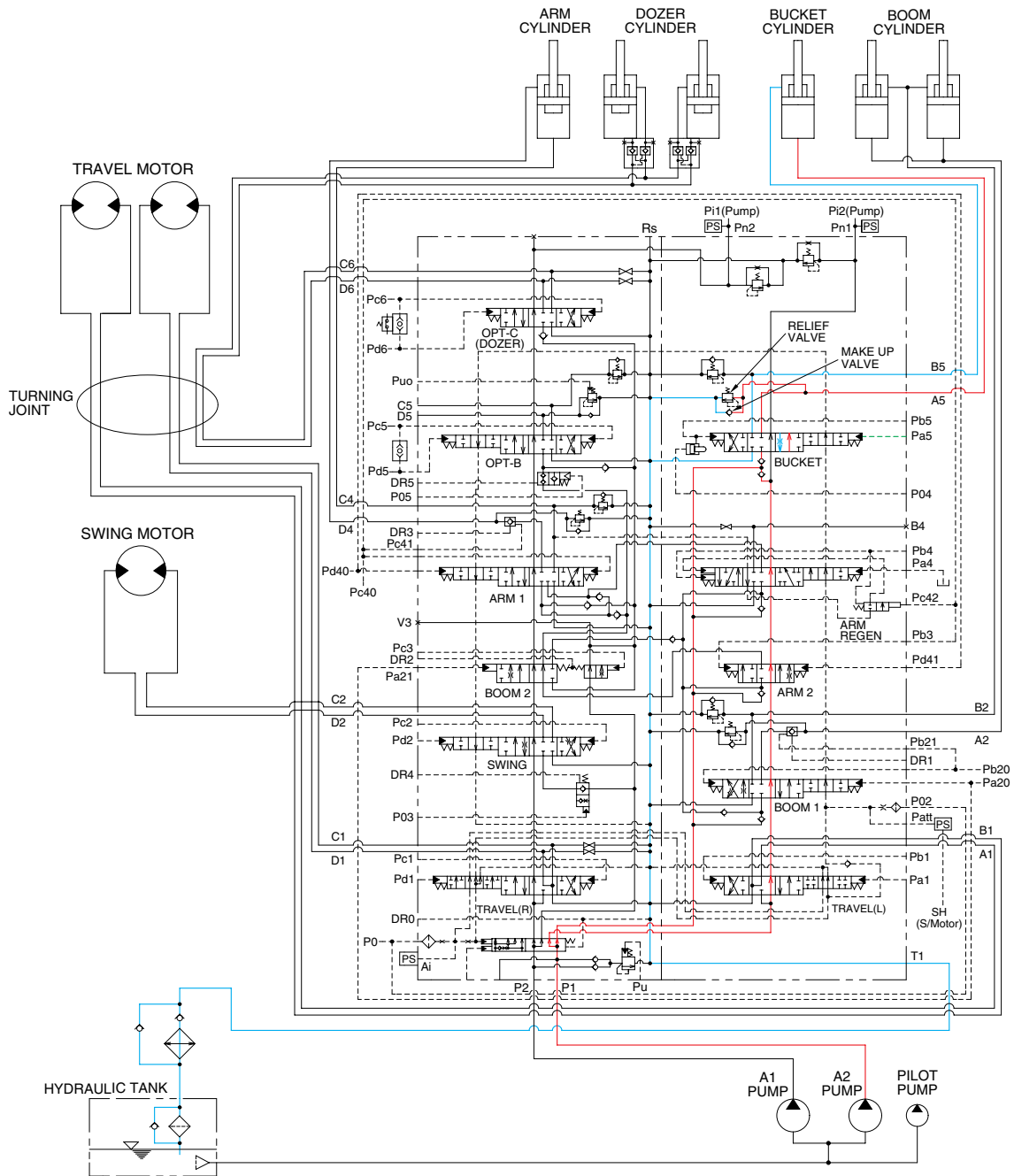

1609A3HC14

When the right control lever is pulled left, the bucket spool in the main control valve is moved to the roll in position by the pilot oil pressure from the remote control valve.

The oil from the A2 pump flows into the main control valve and then goes to the large chamber of bucket cylinder.

At the same time, the oil from the small chamber of bucket cylinder returns to the hydraulic oil tank through the bucket spool in the main control valve. When this happens, the bucket rolls in.

The excessive pressure in the bucket cylinder head side is prevented by relief valve.

The cavitation which will happen to the head side of the bucket cylinder is also prevented by the make-up valve in the main control valve.

## 6. BUCKET OUT OPERATION

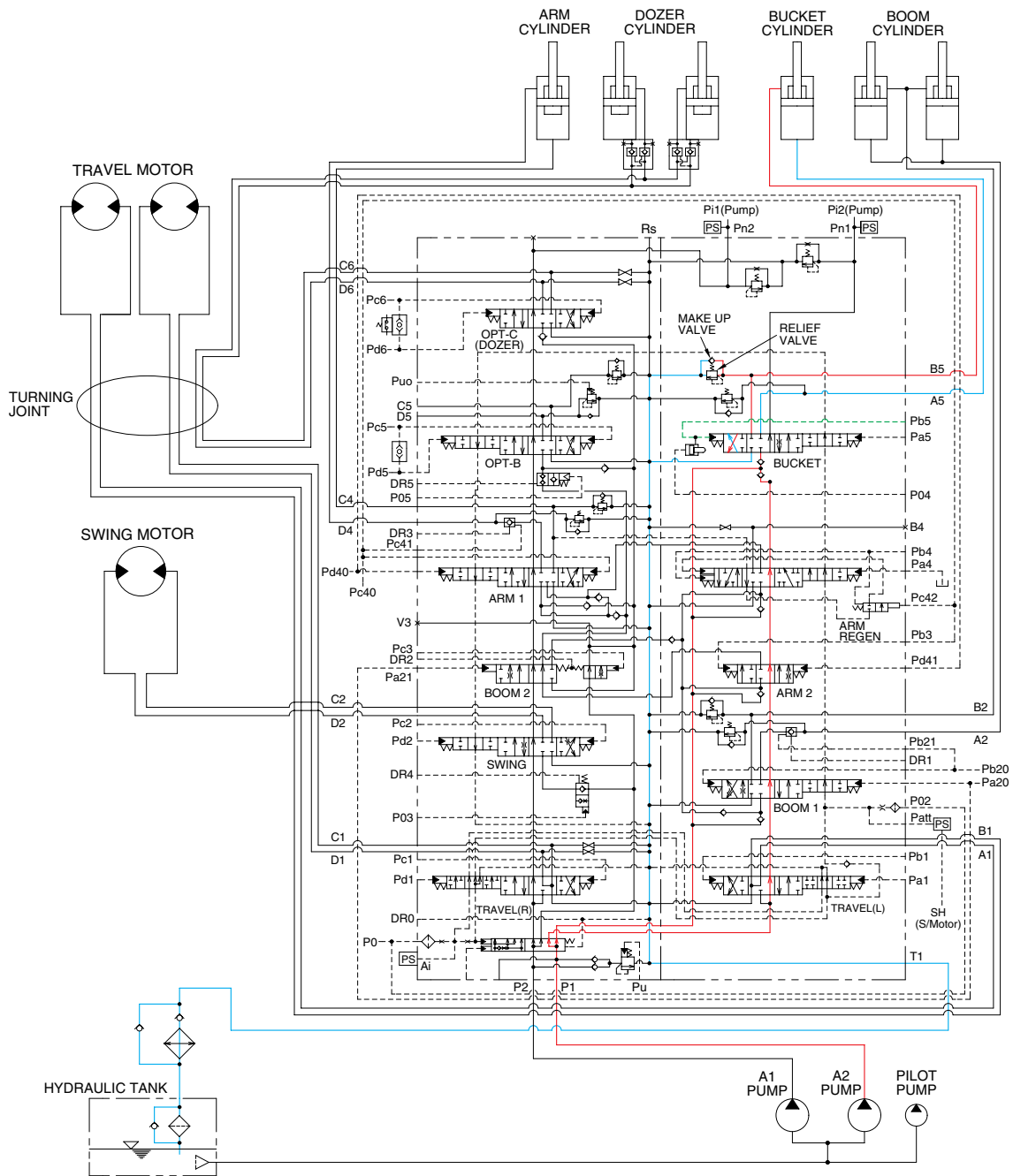

When the right control lever is pushed right, the bucket spool in the main control valve is moved to the bucket out position by the pilot oil pressure from the remote control valve. The oil from the A2 pump flows into the main control valve and then goes to the small chamber of bucket cylinder. At the same time, the oil from the large chamber of bucket cylinder returns to the hydraulic oil tank through the bucket spool in the main control valve. When this happens, the bucket rolls out. The cavitation which will happen to the rod side of the bucket cylinder is also prevented by the make-up valve in the main control valve.

## 7. DOZER UP OPERATION

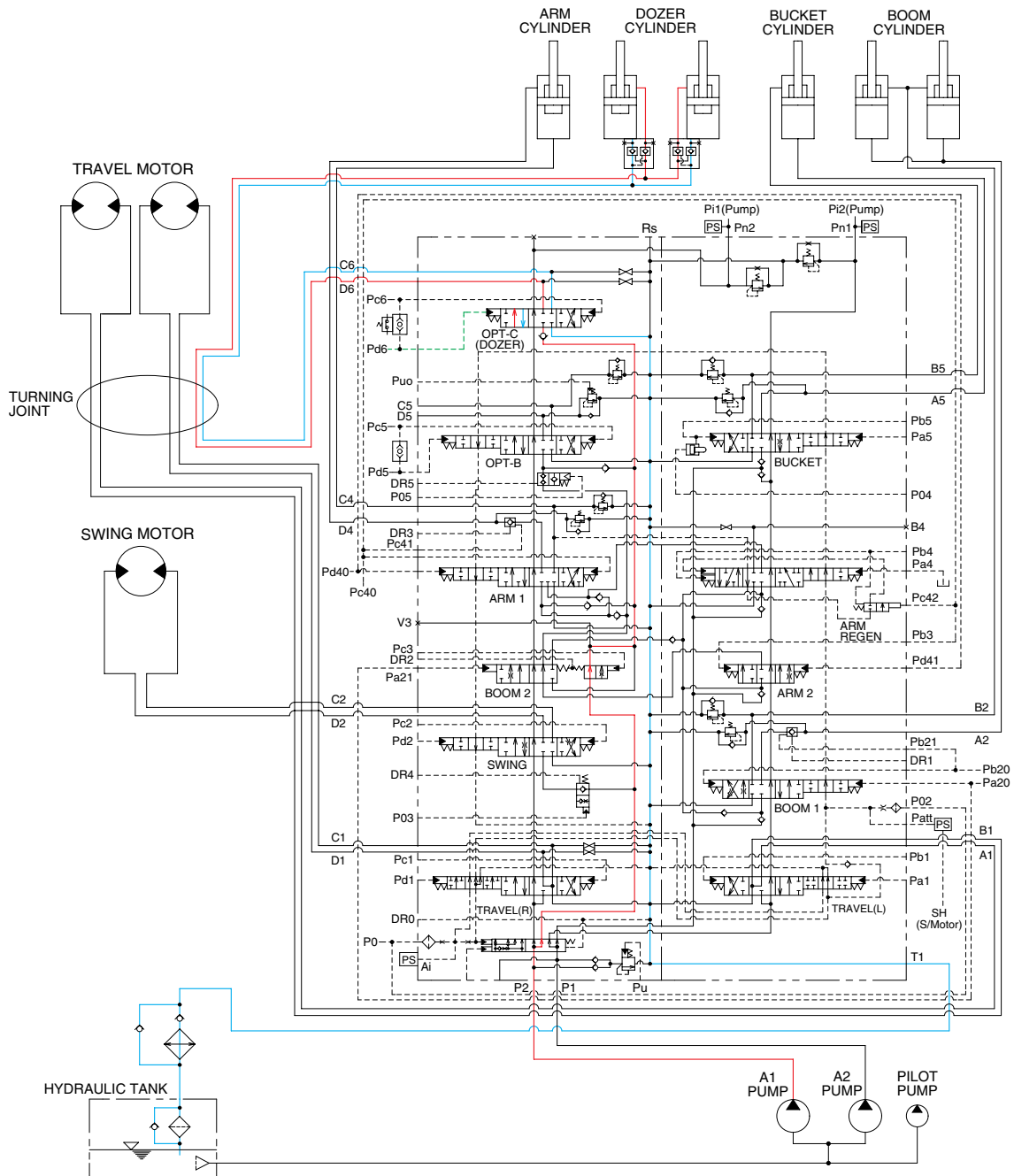

When the dozer control lever is pulled back, the dozer spool in the main control valve is moved to the dozer up position by the pilot oil pressure from the remote control valve.

The oil from the A1 pump flows into the main control valve and then goes to the small chamber of dozer cylinder.

At the same time, the oil from the large chamber of dozer cylinders returns to the hydraulic oil tank through the dozer spool in the main control valve. When this happens, the dozer goes up.

## 8. DOZER DOWN OPERATION

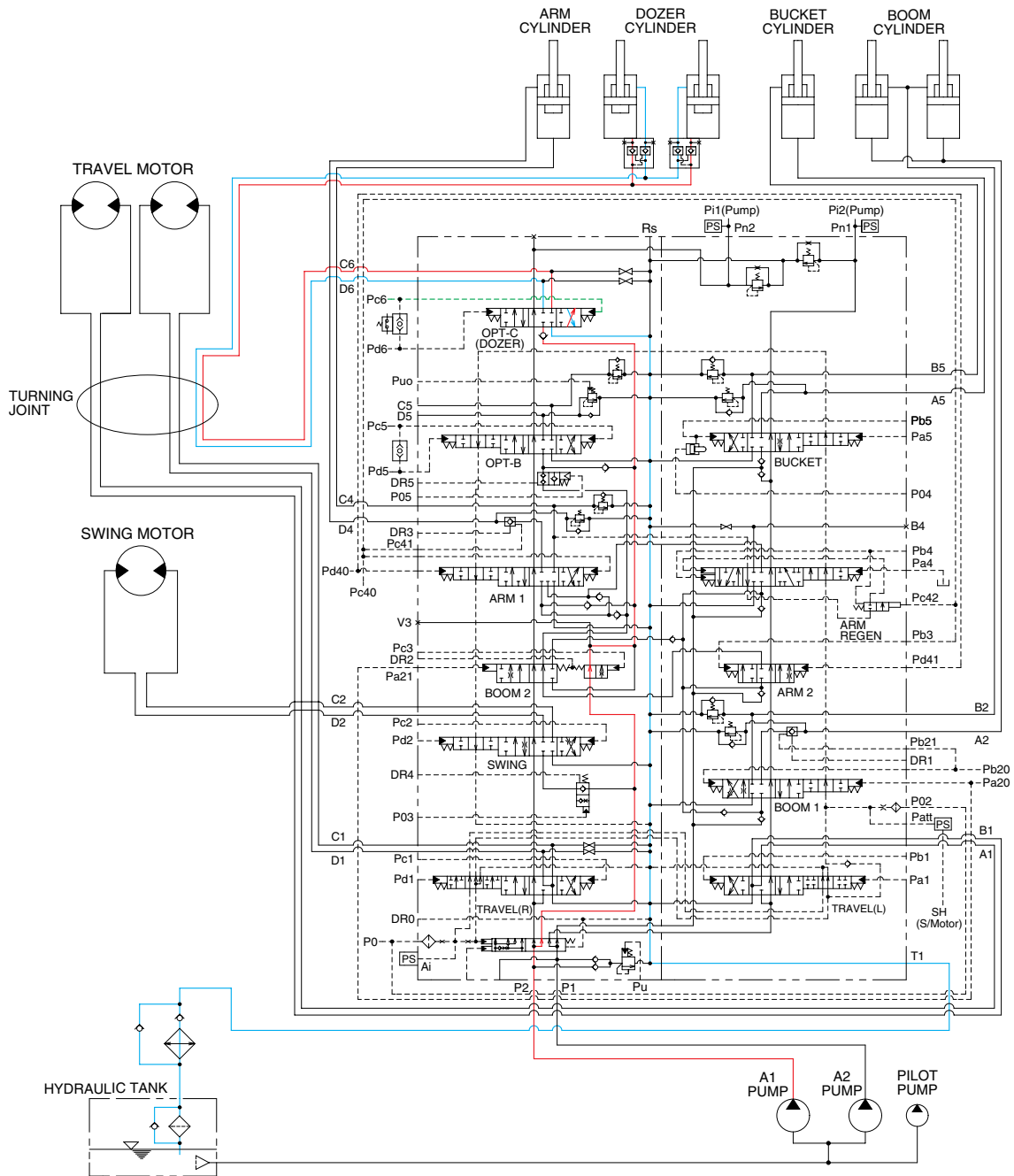

1609A3HC17

When the dozer control lever is pushed forward, the dozer spool in the main control valve is moved to the dozer down position by the pilot oil pressure from the remote control valve.

The oil from the A1 pump flows into the main control valve and then goes to the large chamber of dozer cylinder.

At the same time, the oil from the small chamber of dozer cylinders returns to the hydraulic oil tank through the dozer spool in the main control valve. When this happens, the dozer goes down.



## 9. SWING OPERATION

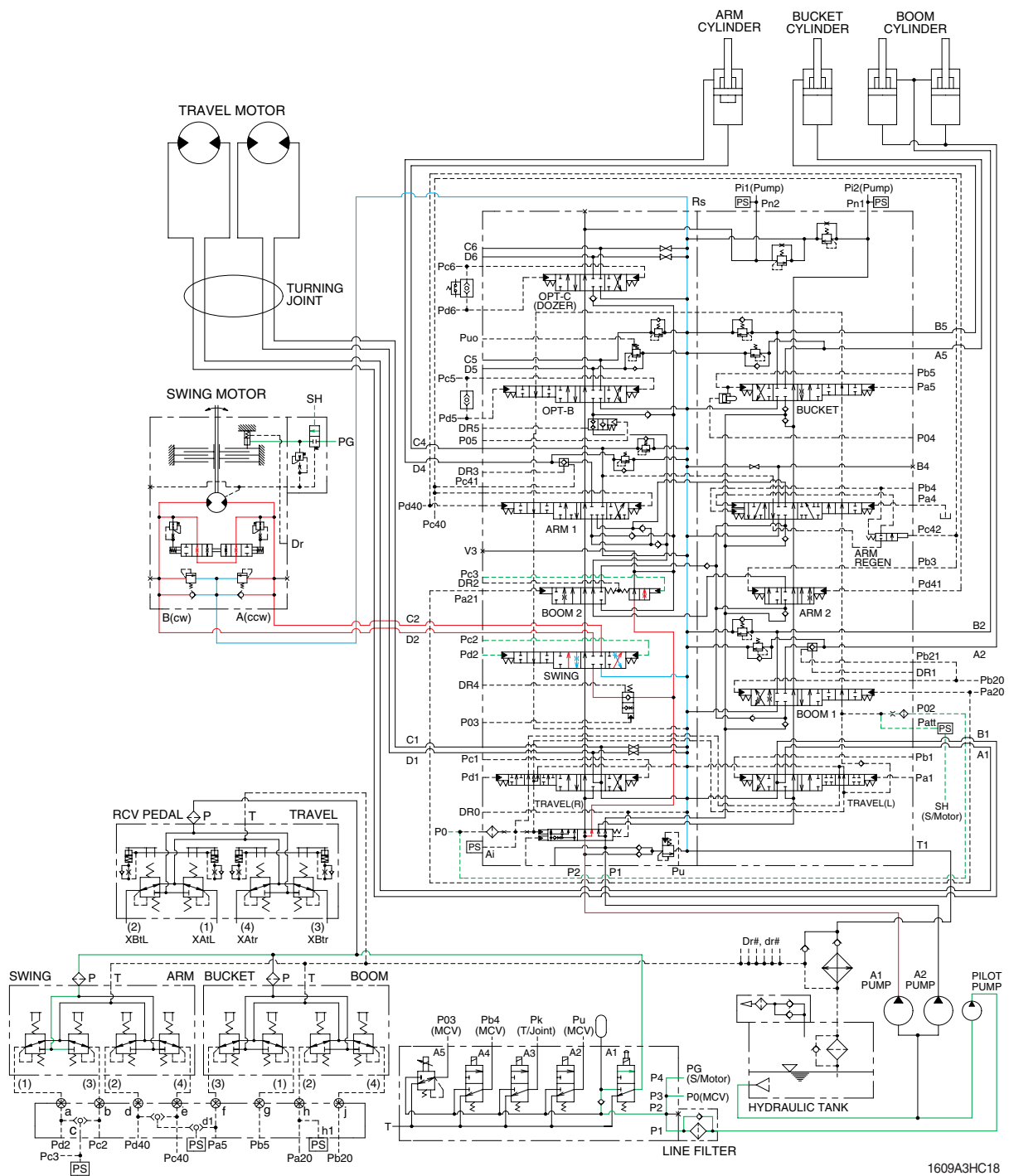

1609A3HC18

When the left control lever is pushed left or right, the swing spool in the main control valve is moved to the left or right swing position by the pilot oil pressure from the remote control valve.

Also the swing operation preference function is operated by the pilot pressure Pc3 (refer to page 2-38).

The oil from the A1 pump flows into the main control valve and then goes to the swing motor.

At the same time, the return oil from the swing motor returns to the hydraulic oil tank through the swing spool in the main control valve.

When this happens, the upper structure swings to the left or right.

The swing parking brake, make up valve and the motor brake valve are provided in the swing motor.

The cavitation which will happen to the swing motor is also prevented by the make up valve in the swing motor itself.

## SWING CIRCUIT OPERATION

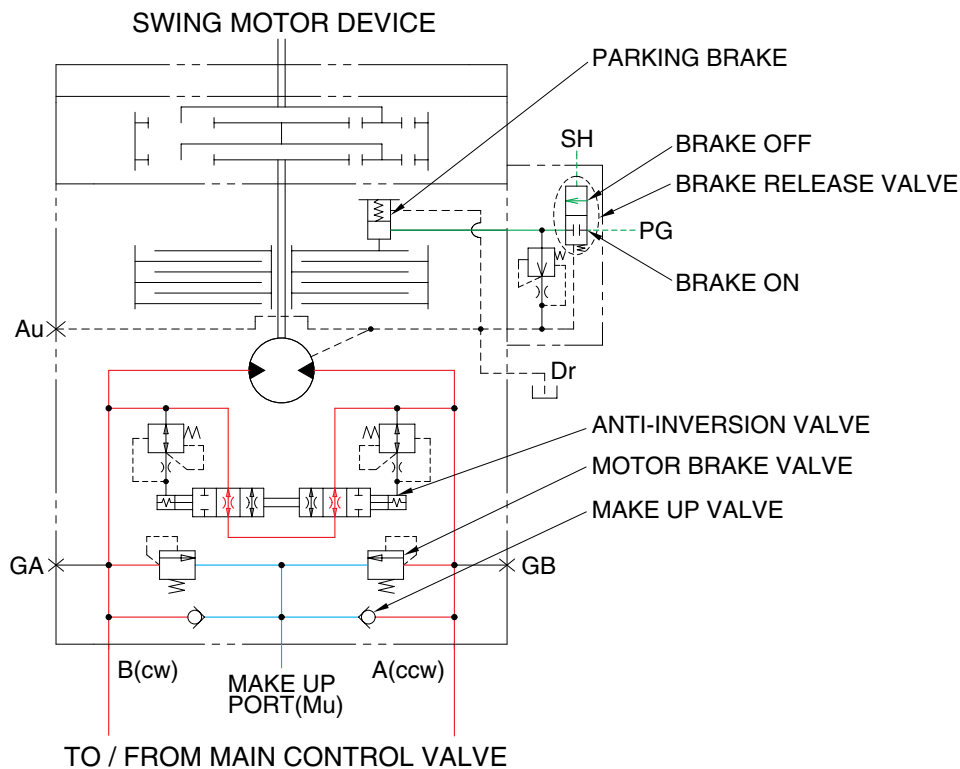

14W93HC18A

### 1) MOTOR BRAKE VALVE

Motor brake valve for the swing motor limits to cushion the starting and stopping pressure of swing operation and controls the swing motor operating pressure.

### 2) MAKE UP VALVE

The make up valves prevent cavitation by supplying return oil to the vacuum side of the motor.

### 3) PARKING BRAKE

This is function as a parking brake only when all of the RCV lever (except dozer lever and travel pedal) are not operated.

#### PARKING BRAKE "OFF" OPERATION

The parking brake is released by the pilot pressure oil from the pilot pump.

When the RCV lever placed in the operating position, the pilot oil flows into SH port through the MCV. This pressure transferred to the brake release valve and the brake release valve is change over. Then the pilot oil pressure PG lift the brake piston and release the parking brake.

#### PARKING BRAKE "ON" OPERATION

When all of the RCV lever placed in the neutral position, the pressure of the pilot oil passage down. Then the brake release valve returned to the neutral position and the oil is returned from the brake piston to the tank. And the brake is set to 'ON'.

### 4) ANTI-INVERSION VALVE

This anti-inversion valve absorbs shocks produced as swing motion stops and reduced oscillation cause by swing motion.

## 8. TRAVEL FORWARD AND REVERSE OPERATION

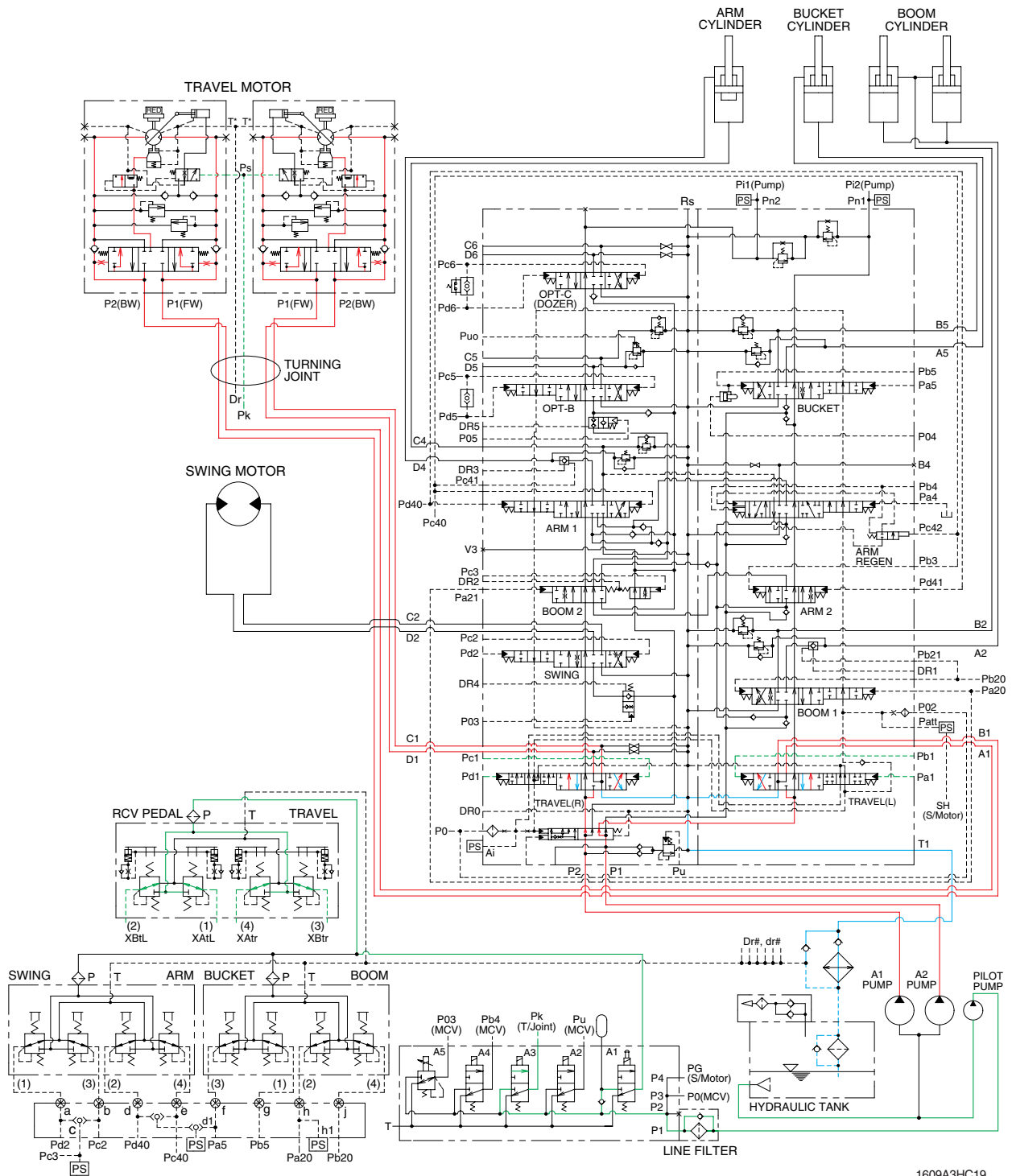

1609A3HC19

When the travel levers are pushed forward or reverse position, the travel spools in the main control valve are moved to the forward or reverse travel position by the pilot oil pressure from the remote control valve.

The oil from the each pump flows into the main control valve and then goes to the each travel motor through the turning joint.

The return oil from both travel motors returns to the hydraulic oil tank through the turning joint and the travel spools in the main control valve.

When this happens, the machine moves to the forward or reverse.

## TRAVEL CIRCUIT OPERATION

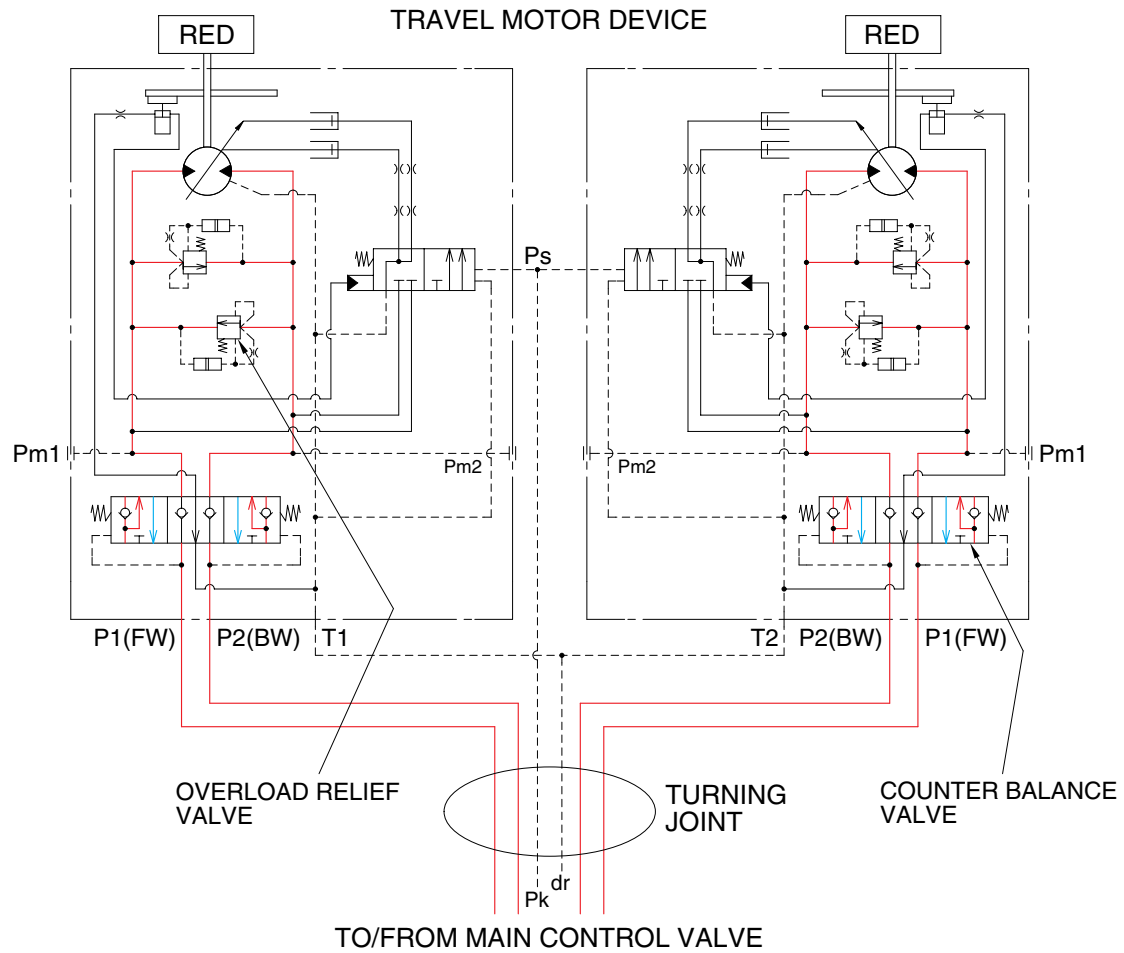

16093HC19A

Valves are provided on travel motors to offer the following functions.

### 1) COUNTER BALANCE VALVE

When stopping the motor of slope descending, this valve to prevent the motor over run.

### 2) OVERLOAD RELIEF VALVE

Relief valve limit the circuit pressure below 350 kgf/cm<sup>2</sup> to prevent high pressure generated at a time of stopping the machine. Stopping the motor, this valve sucks the oil from lower pressure passage for preventing the negative pressure and the cavitation of the motor.