

## SECTION 4 ELECTRICAL SYSTEM

Group 1 Component Location .....	4-1
Group 2 Electrical Circuit .....	4-3
Group 3 Electrical Component Specification .....	4-21
Group 4 Connectors .....	4-29

# SECTION 4 ELECTRICAL SYSTEM

## GROUP 1 COMPONENT LOCATION

### 1. LOCATION 1

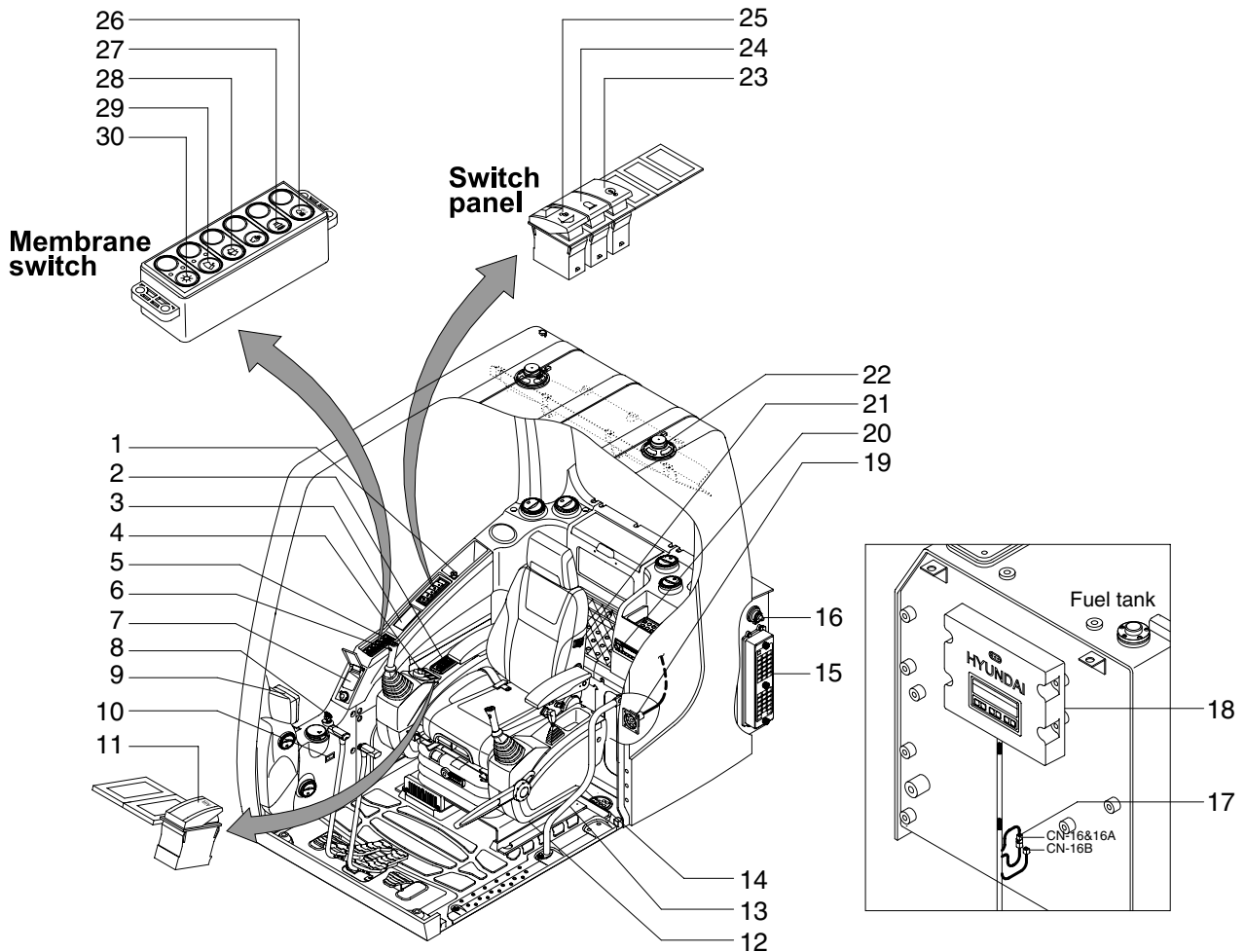

1409A4EL12

- |                            |                                 |                        |
|----------------------------|---------------------------------|------------------------|
| 1 Cigar lighter            | 11 Air compressor switch        | 21 Heated seat switch  |
| 2 Air conditioner switch   | 12 Safety lever                 | 22 Speaker             |
| 3 Remote controller        | 13 Power max switch             | 23 Overload switch     |
| 4 Accel dial switch        | 14 One touch decel switch       | 24 Beacon switch       |
| 5 Horn switch              | 15 Emergency engine connector   | 25 Quick clamp switch  |
| 6 Breaker operation switch | 16 Fuse & relay box             | 26 Cab light switch    |
| 7 Handsfree                | 17 Master switch                | 27 Travel alarm switch |
| 8 Start switch             | 18 Machine control unit         | 28 Washer switch       |
| 9 Cluster                  | 19 RS232 & J1939 service socket | 29 Wiper switch        |
| 10 Hour meter              | 20 Radio & USB player           | 30 Main light switch   |

## 2. LOCATION 2

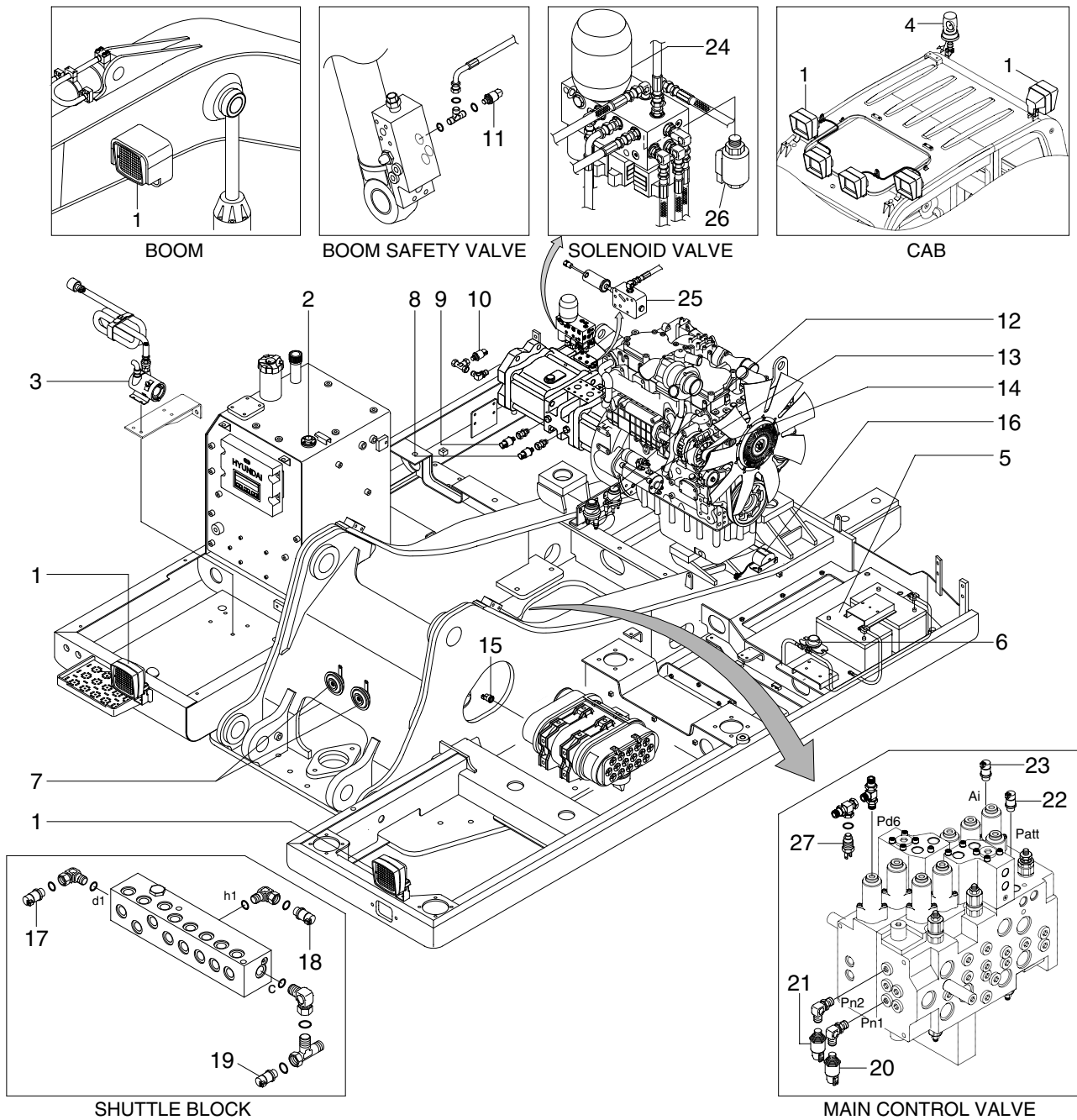

1609A4EL13

- |                      |                                  |                               |
|----------------------|----------------------------------|-------------------------------|
| 1 Lamp               | 10 P3 pressure sensor            | 19 Swing pressure sensor      |
| 2 Fuel sender        | 11 Overload pressure sensor      | 20 Negative 1 pressure sensor |
| 3 Fuel filler pump   | 12 Heater relay                  | 21 Negative 2 pressure sensor |
| 4 Beacon lamp        | 13 Alternator                    | 22 Attach pressure sensor     |
| 5 Battery            | 14 Start relay                   | 23 Travel pressure sensor     |
| 6 Battery relay      | 15 Air cleaner switch            | 24 Solenoid valve             |
| 7 Horn               | 16 Travel alarm buzzer           | 25 Pump EPPR valve            |
| 8 P1 pressure sensor | 17 Arm/Bucket in pressure sensor | 26 Boom priority EPPR valve   |
| 9 P2 pressure sensor | 18 Boom up pressure sensor       | 27 Dozer pressure switch      |