

SECTION 3 HYDRAULIC SYSTEM

Group 1 Hydraulic Circuit	3-1
---------------------------------	-----

SECTION 3 HYDRAULIC SYSTEM

GROUP 1 HYDRAULIC CIRCUIT

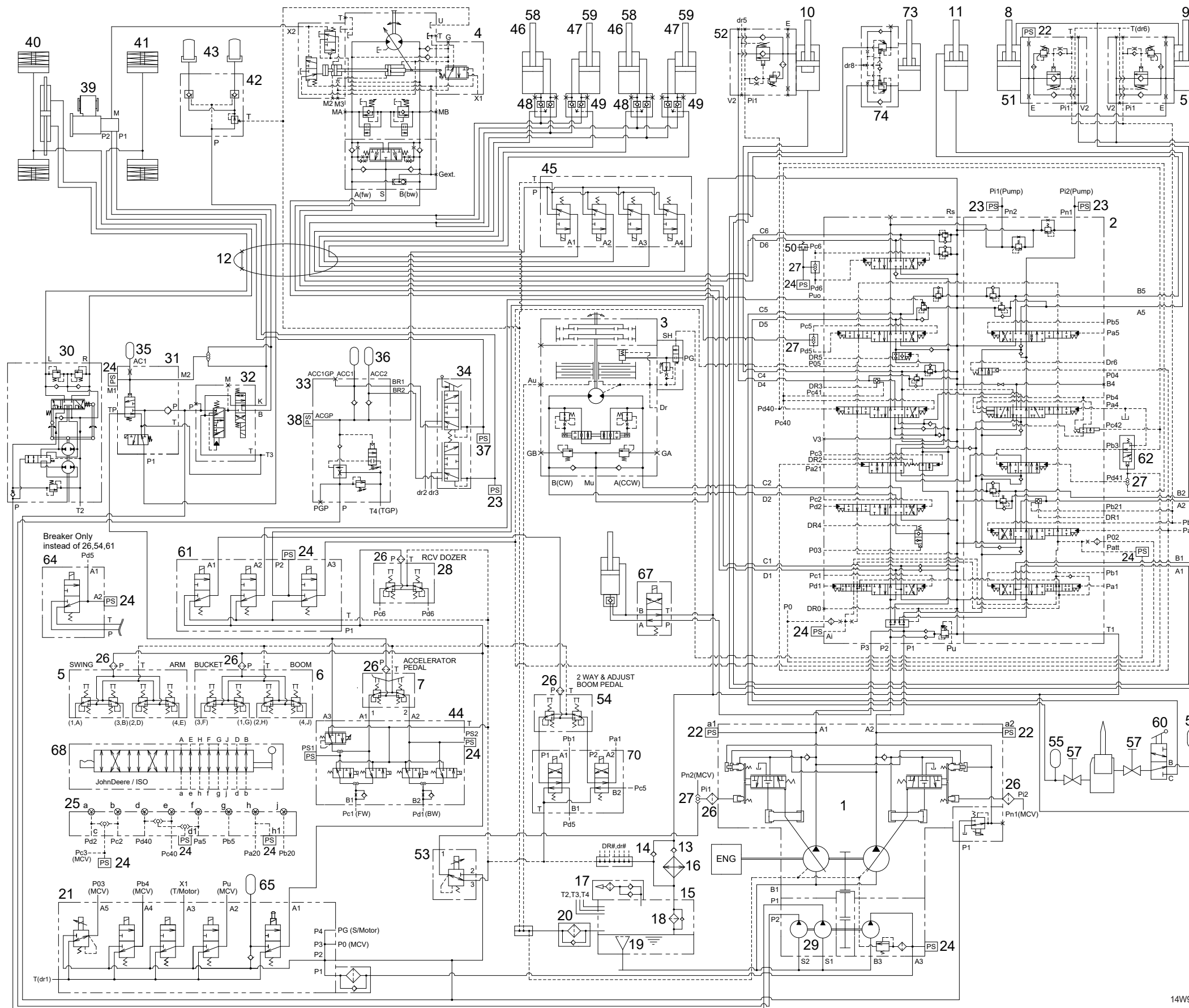

- 1 Main pump
- 2 Main control valve
- 3 Swing motor
- 4 Travel motor
- 5 RCV lever(LH)
- 6 RCV lever(RH)
- 7 Accelerator pedal
- 8 Boom cylinder(LH)
- 9 Boom cylinder(RH)
- 10 Arm cylinder
- 11 Bucket cylinder
- 12 Turning joint
- 13 Check valve
- 14 Check valve
- 15 Hydraulic tank
- 16 Oil cooler
- 17 Air breather
- 18 Bypass valve & return element
- 19 Strainer assy
- 20 Drain filter
- 21 5 solenoid valve & pilot line filter
- 22 Pressure sensor(500k)
- 23 Pressure sensor(100k)
- 24 Pressure sensor(50k)
- 25 Shuttle block
- 26 Last guard filter
- 27 Shuttle valve
- 28 RCV dozer(option)
- 29 Power train pump
- 30 Steering valve
- 31 Travel control valve
- 32 TCV valve
- 33 Brake supply valve
- 34 Brake valve
- 35 Accumulator(option)
- 36 Accumulator(option)
- 37 Pressure sensor(5k)
- 38 Pressure sensor(200k)
- 39 Transmission
- 40 Front axle
- 41 Rear axle
- 42 Locking valve
- 43 Oscillating cylinder
- 44 5 solenoid valve(option)
- 45 4 solenoid valve(option)
- 46 Outrigger cylinder(LH, option)
- 47 Outrigger cylinder(RH, option)
- 48 Pilot check valve(LH, option)
- 49 Pilot check valve(RH, option)
- 50 Pressure switch(option)
- 51 Boom safety lock valve(option)
- 52 Arm safety lock valve(option)
- 53 EPPR valve(option)
- 54 2 way & adjust boom pedal(option)
- 55 Accumulator(option)
- 56 Accumulator(option)
- 57 Stop valve(option)
- 58 Dozer cylinder(LH, option)
- 59 Dozer cylinder(RH, option)
- 60 Breaker selector valve(option)
- 61 Solenoid valve(option)
- 62 Selector valve(option)
- 64 Breaker solenoid valve(option)
- 65 Accumulator(option)
- 67 Quick clamp solenoid valve(option)
- 68 Pattern change valve(option)
- 70 Selector solenoid valve(option)
- 73 Adjustable boom cylinder(option)
- 74 Adjustable boom safety lock valve(option)

14W93HC01