

SECTION 5 MECHATRONICS SYSTEM

Group 1 Outline.....	5-1
Group 2 Mode Selection System	5-3
Group 3 Automatic Deceleration System	5-6
Group 4 Power Boost System	5-7
Group 5 Travel Speed Control System	5-8
Group 6 Automatic Warming Up System	5-9
Group 7 Engine Overheat Prevention System	5-10
Group 8 Variable Power Control System	5-11
Group 9 Attachment Flow Control System	5-12
Group 10 Anti-Restart System	5-13
Group 11 Self-Diagnostic System	5-14
Group 12 Engine Control System	5-20
Group 13 EPPR Valve	5-21
Group 14 Monitoring System	5-26
Group 15 Fuel Warmer System	5-51

SECTION 5 MECHATRONICS SYSTEM

GROUP 1 OUTLINE

The ADVANCED CAPO (Computer Aided Power Optimization) system controls engine and pump mutual power at an optimum and less fuel consuming state for the selected work by mode selection, auto-deceleration, power boost function, etc. It monitors machine conditions, for instance, engine speed, coolant temperature, hydraulic oil temperature, and hydraulic oil pressure, etc. It consists of a MCU, a cluster, an ECM, EPPR valves, and other components. The MCU and the cluster protect themselves from over-current and high voltage input, and diagnose malfunctions caused by short or open circuit in electric system, and display error codes on the cluster.

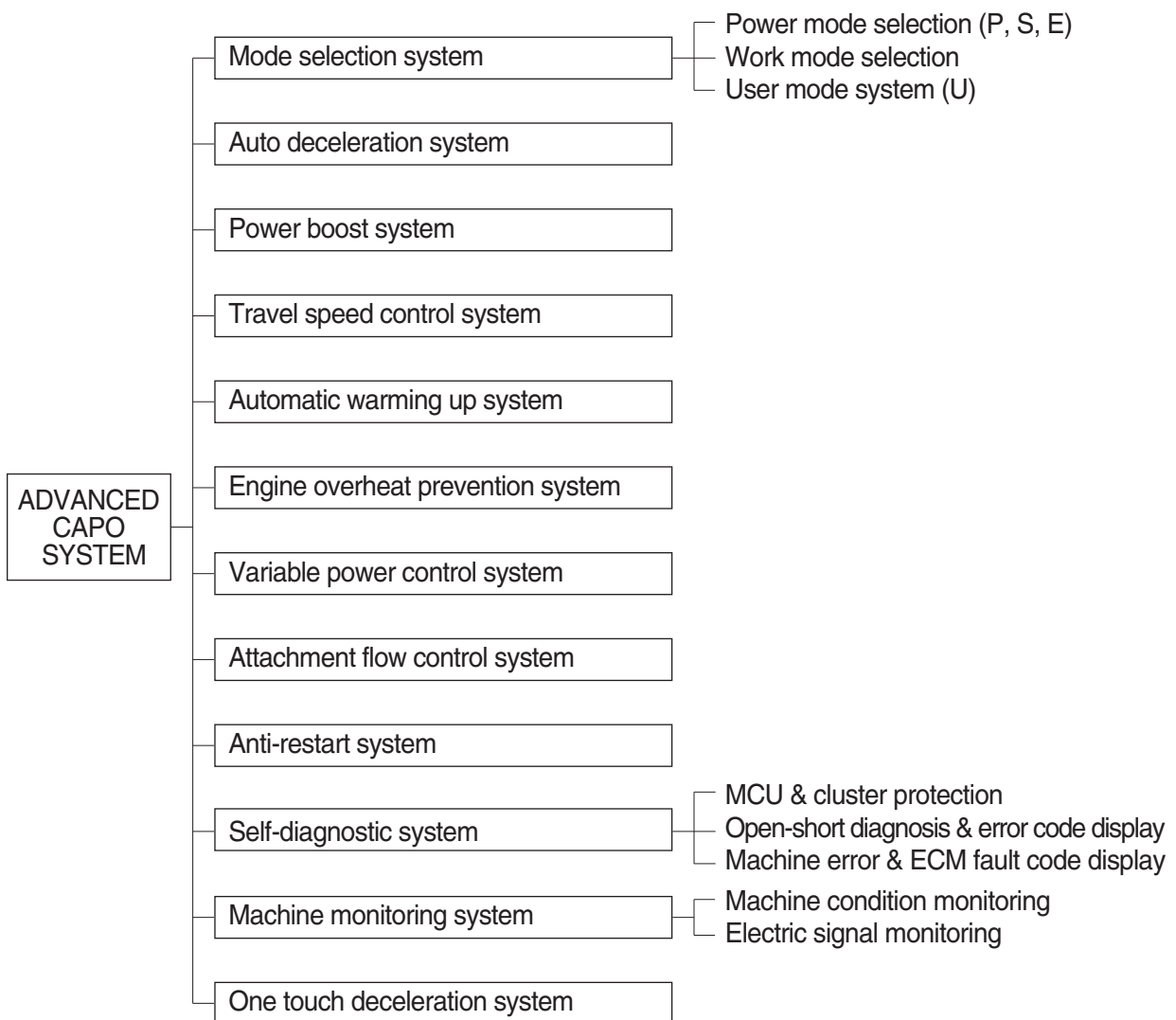

SYSTEM DIAGRAM

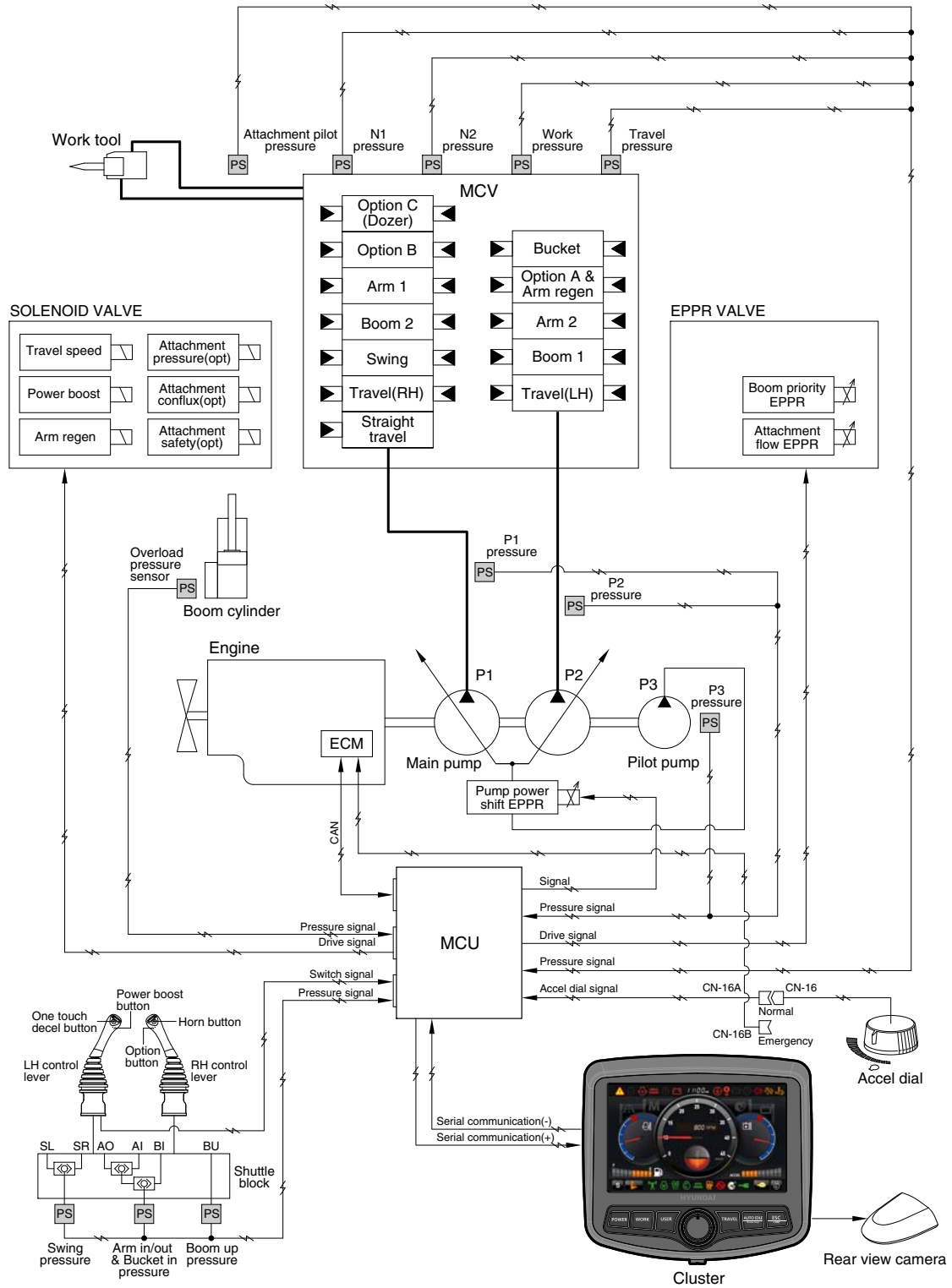

145Z9A5MS01

GROUP 2 MODE SELECTION SYSTEM

1. POWER MODE SELECTION SYSTEM

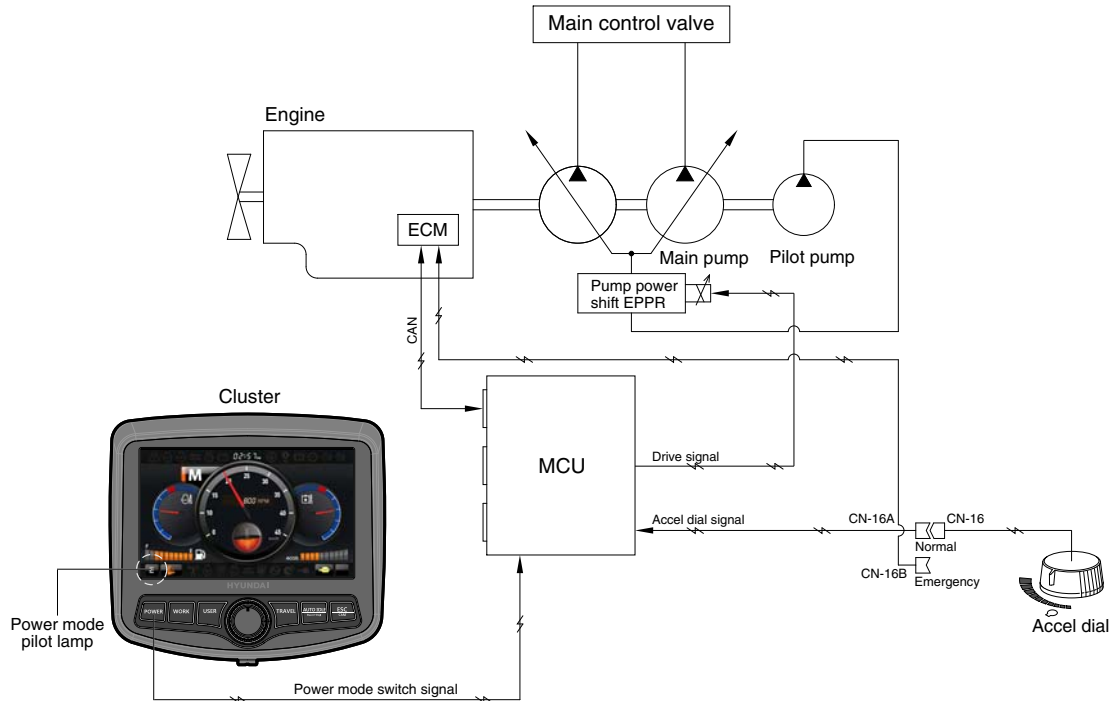

2609A5MS02

Mode selection system (micro computer based electro-hydraulic pump and engine mutual control system) optimizes the engine and pump performance.

The combination of 3 power modes (P, S, E) and accel dial position (10 set) makes it possible to use the engine and pump power more effectively corresponding to the work conditions from a heavy and great power requesting work to a light and precise work.

Power mode	Application	Engine rpm				Power shift by EPPR valve			
		Standard		Option		Standard		Option	
		Unload	Load	Unload	Load	Current (mA)	Pressure (kgf/cm ²)	Current (mA)	Pressure (kgf/cm ²)
P	Heavy duty power	1850±50	1950±50	2100±50	2050±50	290±30	10	160±30	0
S	Standard power	1750±50	1850±50	2000±50	1950±50	360±30	13±3	250±30	5±3
E	Economy operation	1650±50	1750±50	1750±50	1850±50	360±30	15±3	280±30	10±3
AUTO DECEL	Engine deceleration	1100±100	-	1100±100	-	700±30	38±3	700±30	38±3
One touch decel	Engine quick deceleration	1000±100	-	1000±100	-	700±30	38±3	700±30	38±3
KEY START	Key switch start position	1000±100	-	1000±100	-	700±30	38±3	700±30	38±3

※ Power shift (Standard/Option) can be changed by "Service menu" in "Management" on the cluster.

2. WORK MODE SELECTION SYSTEM

Work mode consists of the general operation (bucket) and the optional attachment (breaker, crusher).

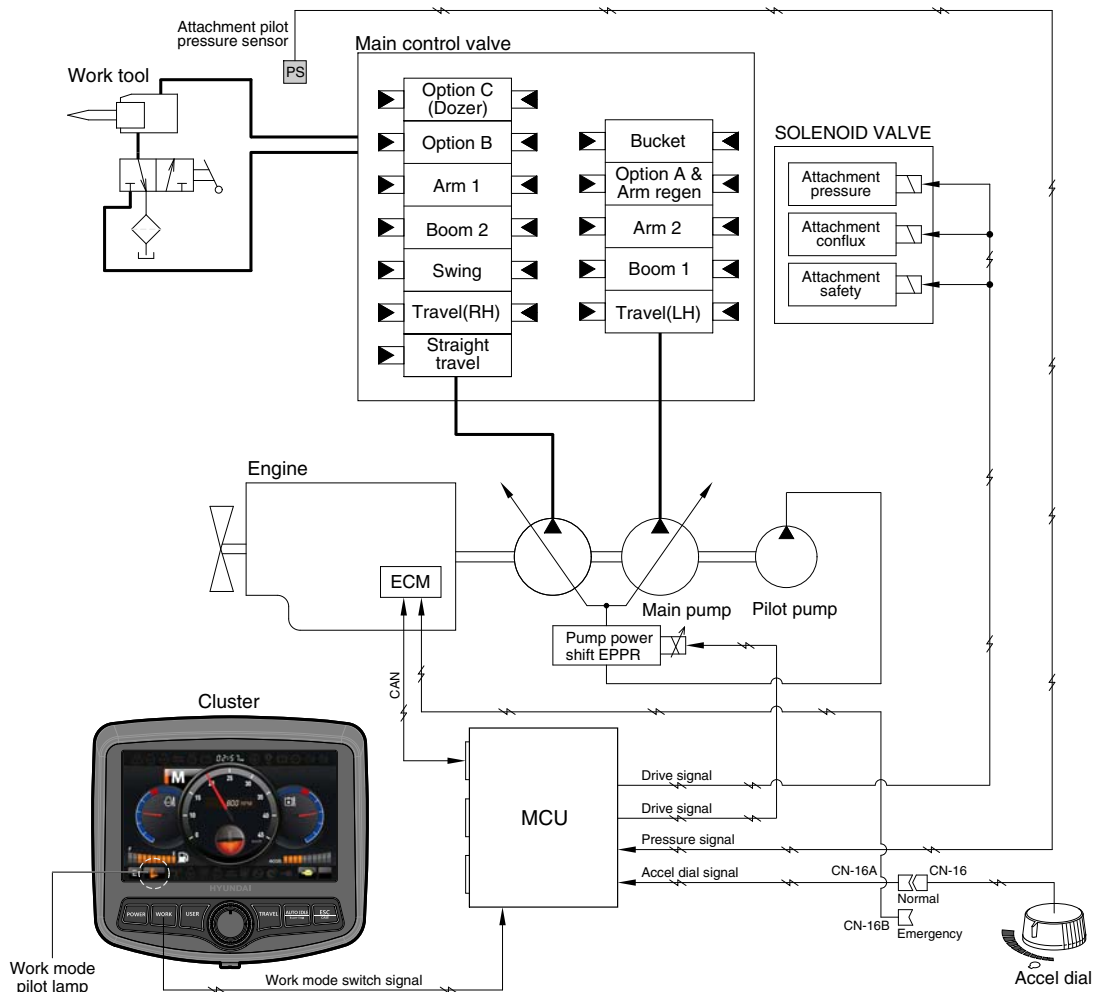

145Z9A5MS02

1) GENERAL WORK MODE (bucket)

This mode is used to general digging work.

2) ATT WORK MODE (breaker, crusher)

It controls the pump flow and system pressure according to the operation of breaker or crusher.

Description	General mode	Work tool	
	Bucket	Breaker	Crusher
Attachment safety solenoid	OFF	ON	ON
Attachment pressure solenoid	OFF	OFF	ON
Attachment conflux solenoid	OFF	OFF	ON/OFF
Attachment flow EPPR current	100 mA	100~700 mA	100~700 mA

3. USER MODE SELECTION SYSTEM

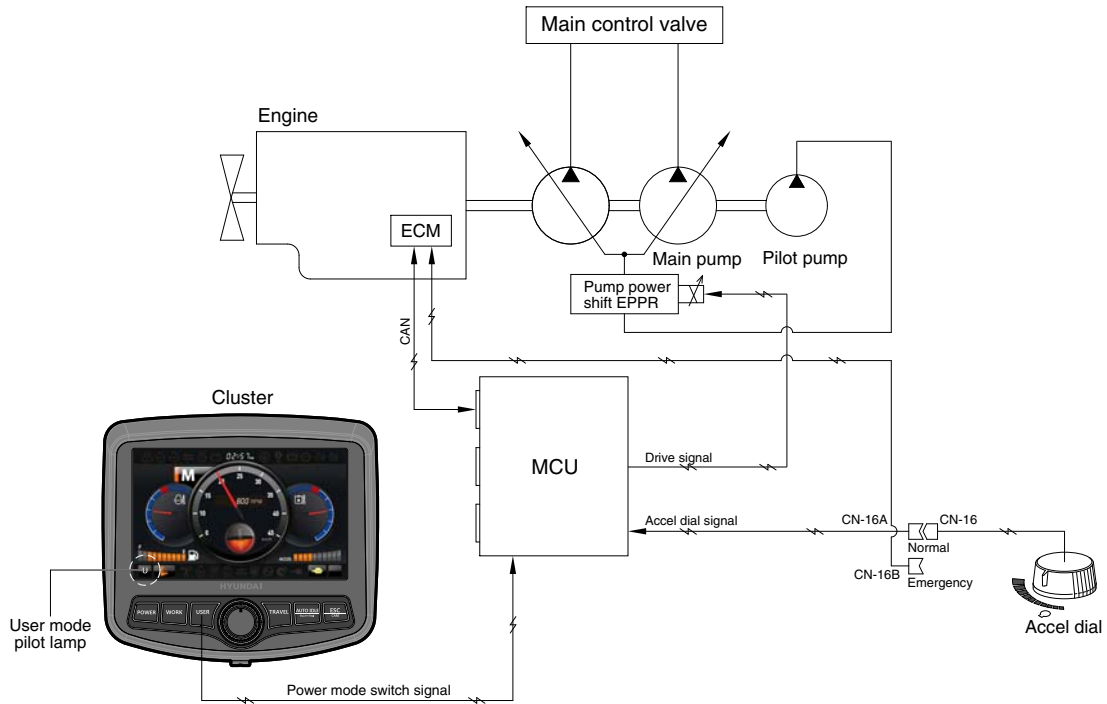

2609A5MS04

1) High idle rpm, auto idle rpm and EPPR pressure can be adjusted and memorized in the U-mode.

2) LCD segment vs parameter setting

Step ()	Engine speed (rpm)	Idle speed (rpm)	Power shift (bar)
1	1300	800	0
2	1400	850	3
3	1500	900	6
4	1600	950	9
5	1700	1000 (low idle)	12
6	1800	1050	16
7	1900	1100 (decel rpm)	20
8	2000	1150	26
9	2050	1200	32
10	2100	1250	38

GROUP 3 AUTOMATIC DECELERATION SYSTEM

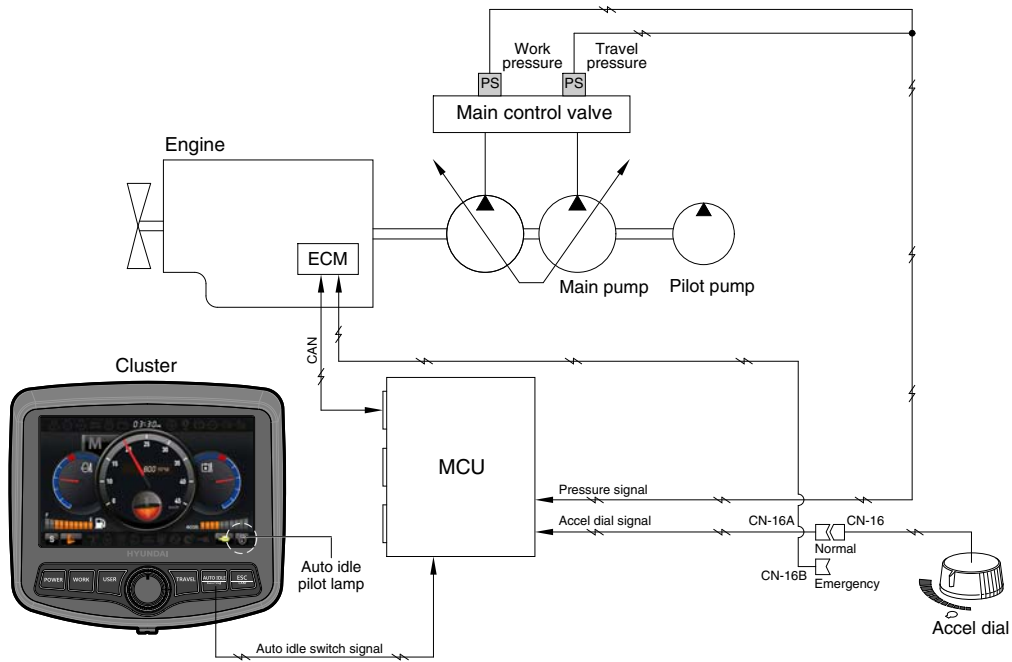

2609A5MS05

1. WHEN AUTO IDLE PILOT LAMP ON

When all of the work equipment control levers including swing and travel levers are at neutral for 4 seconds, MCU sends throttle command to ECM to reduce the engine speed to 1100 rpm. If the control levers are at neutral for 1 minute, MCU reduces the engine speed to 1000 rpm. As the result of reducing the engine speed, fuel consumption and noise are effectively cut down during non-operation of the control levers.

When the Auto idle pilot lamp is turned off by pressing the switch or any control lever is operated, the reduced engine speed rises up to the speed before deceleration in a second.

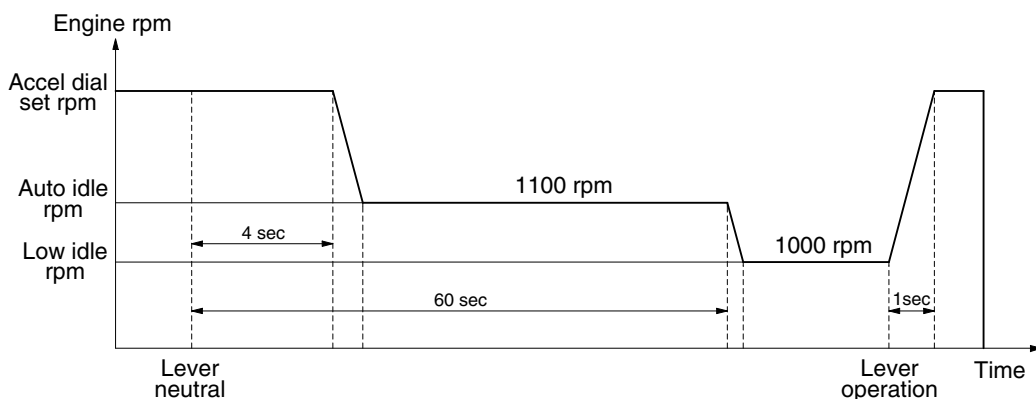

145Z9A5MS03

2. WHEN AUTO IDLE PILOT LAMP OFF

The engine speed can be set as desired using the accel dial switch, and even if the control levers are neutral, the engine speed is not reduced.

※ Auto idle function can be activated when accel dial position is over 4.

GROUP 4 POWER BOOST SYSTEM

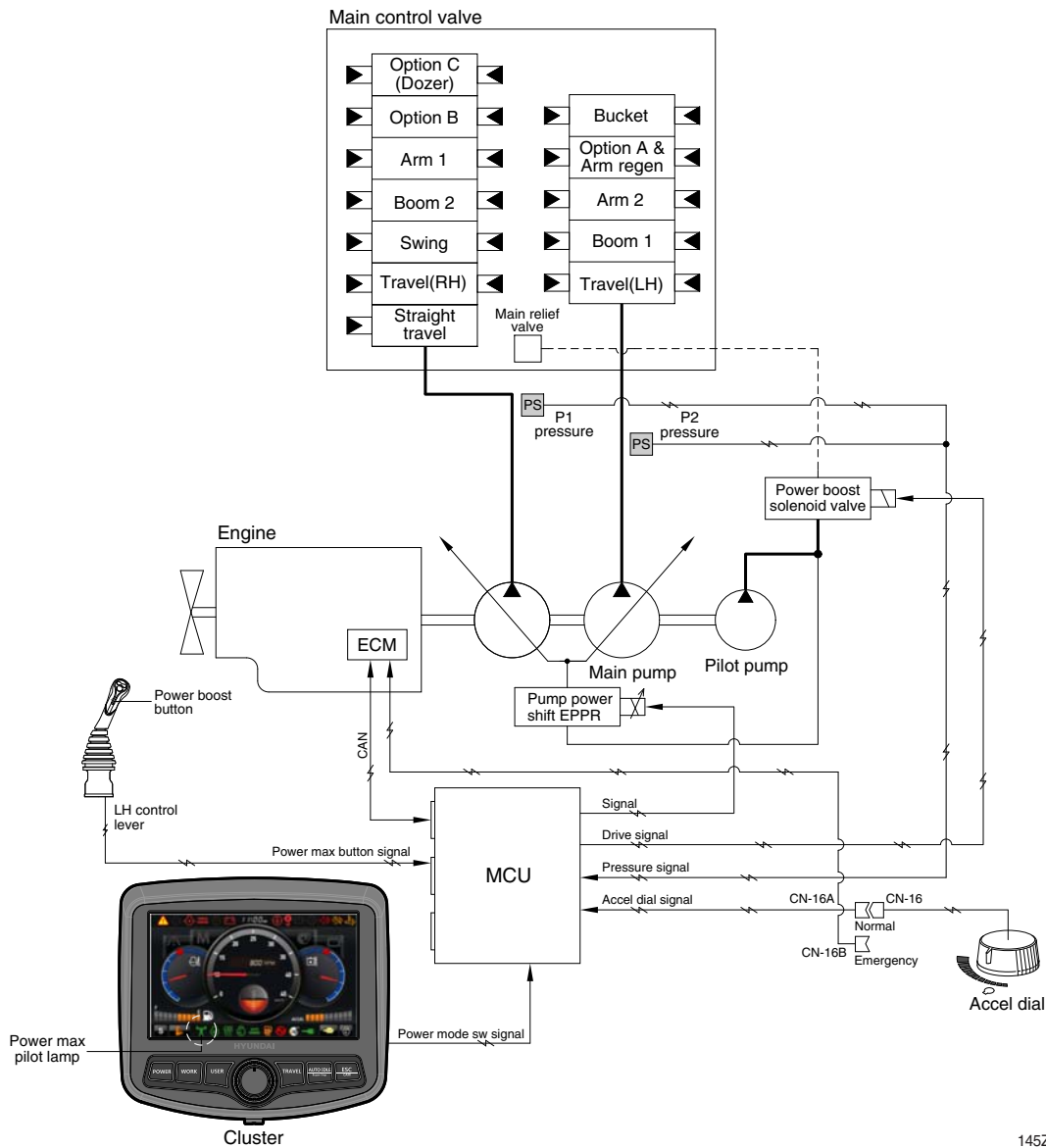

145Z9A5MS04

- When the power boost switch on the left control lever knob is pushed ON, the power mode is set P mode and maximum digging power is increased by 10 %.
- When the power boost function is activated, the power boost solenoid valve pilot pressure raises the set pressure of the main relief valve to increase the digging power.

Description	Condition	Function
Activated	Power boost switch : ON Accel dial : over 8	- Power mode : P - Accel dial power : 9 - Power boost solenoid : ON - Power boost pilot lmap : ON - Operating time : max 8 seconds
Canceled	Power boost switch : OFF	- Pre-set power mode - Power boost solenoid : OFF - Power boost pilot lamp : OFF

- ※ When the auto power boost is set to Enable and power mode is set to P mode on the cluster, the digging power is automatically increased as working conditions by the MCU. It is operated max 8 seconds.

GROUP 5 TRAVEL SPEED CONTROL SYSTEM

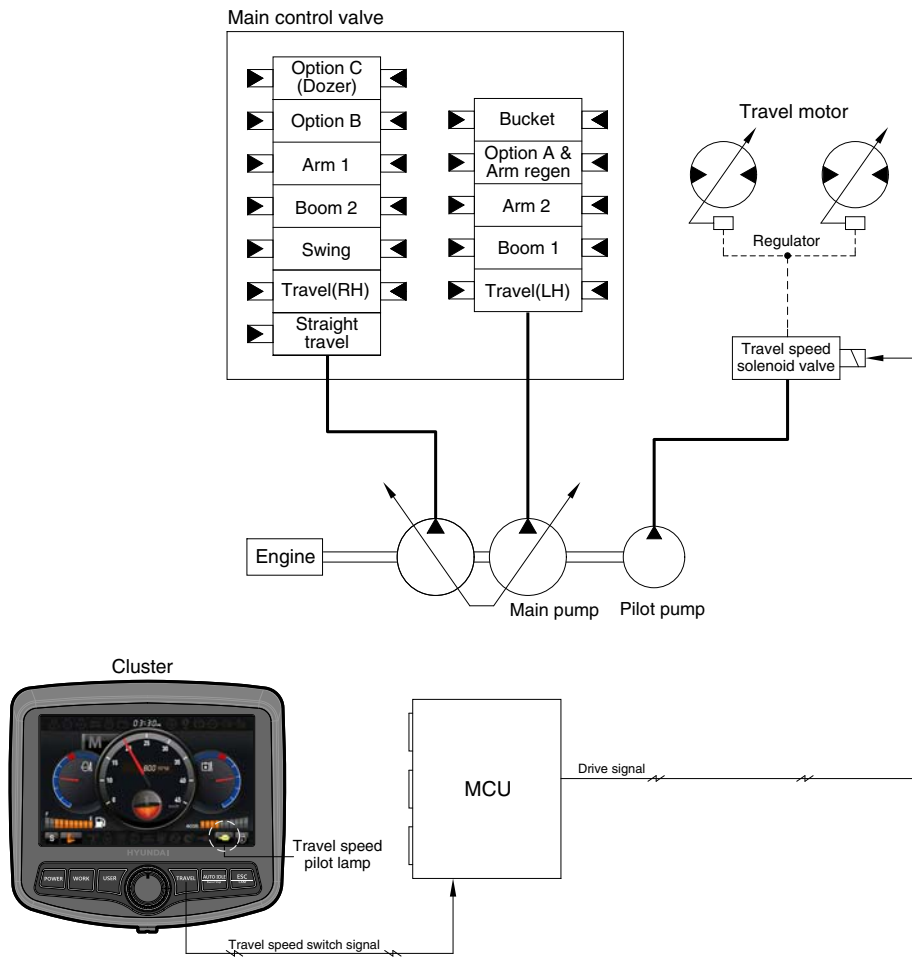

145Z9A5MS05

Travel speed can be switched manually by pressing the travel speed switch on the cluster.

Speed	Travel speed solenoid valve	Lamp on cluster	Operation
Low	OFF	Turtle	Low speed, high driving torque in the travel motor
High	ON	Rabbit	High speed, low driving torque in the travel motor

※ Default : Turtle (Low)

GROUP 6 AUTOMATIC WARMING UP SYSTEM

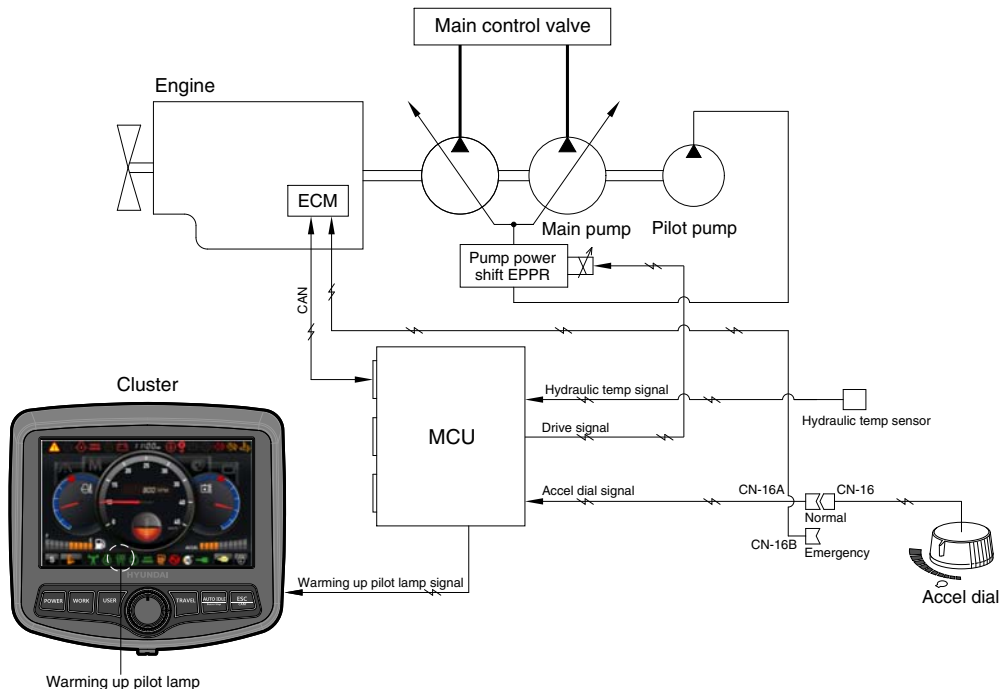

2609A5MS08

1. The MCU receives the engine coolant temperature from the ECM, and if the coolant temperature is below 30°C, engine speed increases to 1200 rpm after 1 minute from engine start. At this time the mode does not change. If the coolant temperature sensor has fault, the hydraulic oil temperature signal is substituted.
2. In case of the coolant temperature increases up to 30°C, the engine speed is decreased to key start speed. And if an operator changes power mode set during the warming up function, the MCU cancels the automatic warming up function.

3. LOGIC TABLE

Description	Condition	Function
Actuated	- Coolant temperature : below 30°C (after engine run)	- Power mode : Default (E mode) - Warming up time : 10 minutes (max) - Warming up pilot lamp : ON
Canceled	- Coolant temperature : Above 30°C - Warming up time : Above 10 minutes - Changed power mode set by operator - RCV lever or pedal operating - Auto idle cancel ※ If any of the above conditions is applicable, the automatic warming up function is canceled	- Power mode : set mode - Warming up pilot lamp : OFF

GROUP 7 ENGINE OVERHEAT PREVENTION SYSTEM

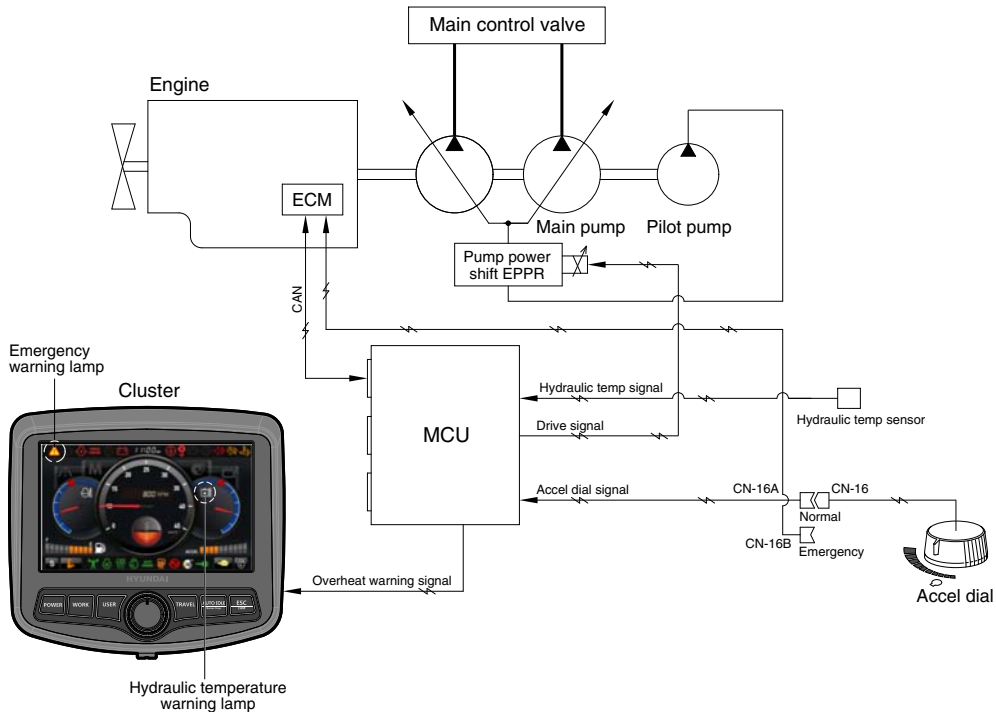

2609A5MS09

1. If the engine coolant temperature or the hydraulic oil temperature is overheated over 100°C, the warning lamp is ON and the pump input torque or the engine speed is reduced as below logic table.

2. LOGIC TABLE

Description		Condition	Function
First step warning	Activated	- Coolant temperature : Above 103°C - Hydraulic oil temperature : Above 100°C	- Warning lamp : ON , buzzer : OFF - Pump input torque is reduced.
	Canceled	- Coolant temperature : Less than 100°C - Hydraulic oil temperature : Less than 95°C	- Warning lamp & buzzer : ON - Pump input torque is reduced.
Second step warning	Activated	- Coolant temperature : Above 107°C - Hydraulic oil temperature : Above 105°C	- Emergency warning lamp pops up on the center of LCD and the buzzer sounds. - Engine speed is reduced after 10 seconds.
	Canceled	- Coolant temperature : Less than 103°C - Hydraulic oil temperature : Less than 100°C	- Return to pre-set the engine speed. - Hold pump absorption torque on the first step warning.

GROUP 8 VARIABLE POWER CONTROL SYSTEM

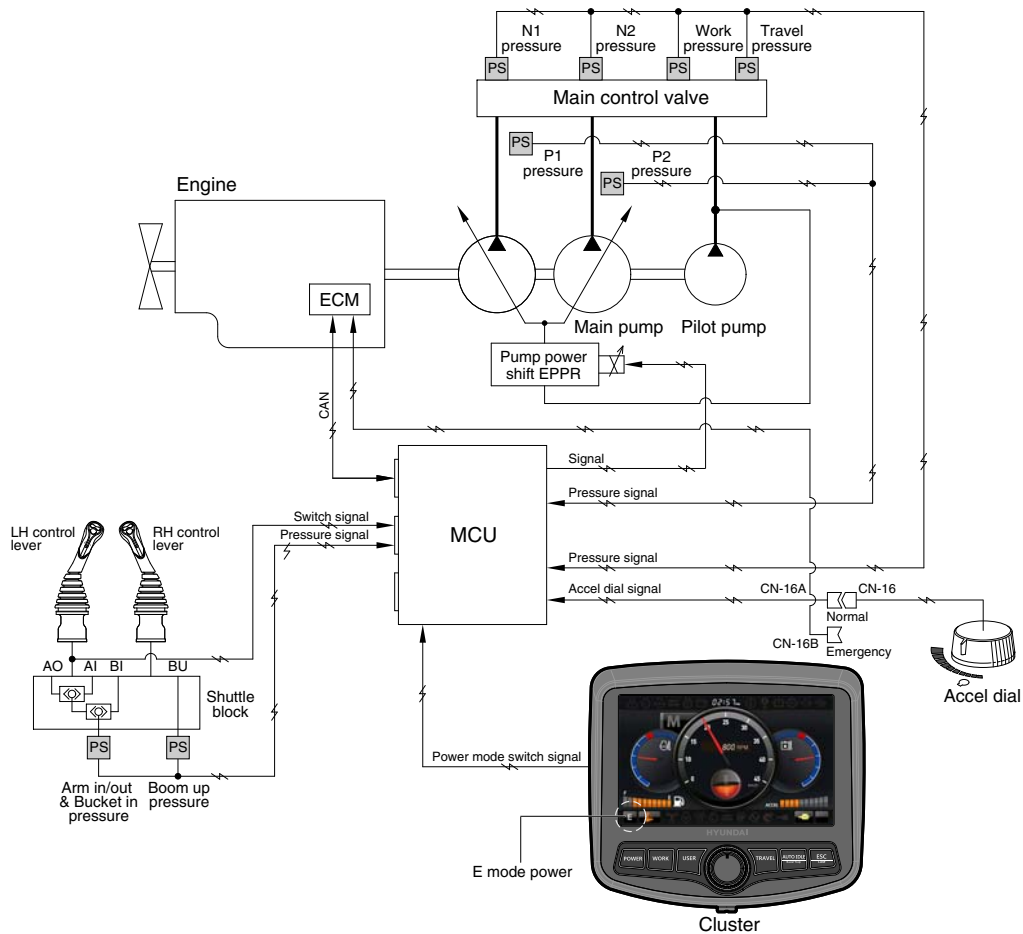

2609A5MS10

- The variable power control system controls the engine and pump mutual power according to RCV lever stroke and pump load. It makes fuel saving and smooth control at precise work.

Description	Working condition
Power mode	E
Work mode	General (bucket)
Pressure sensor	Normal

※ The variable power control function can be activated when the power mode is set to E mode.

GROUP 9 ATTACHMENT FLOW CONTROL SYSTEM

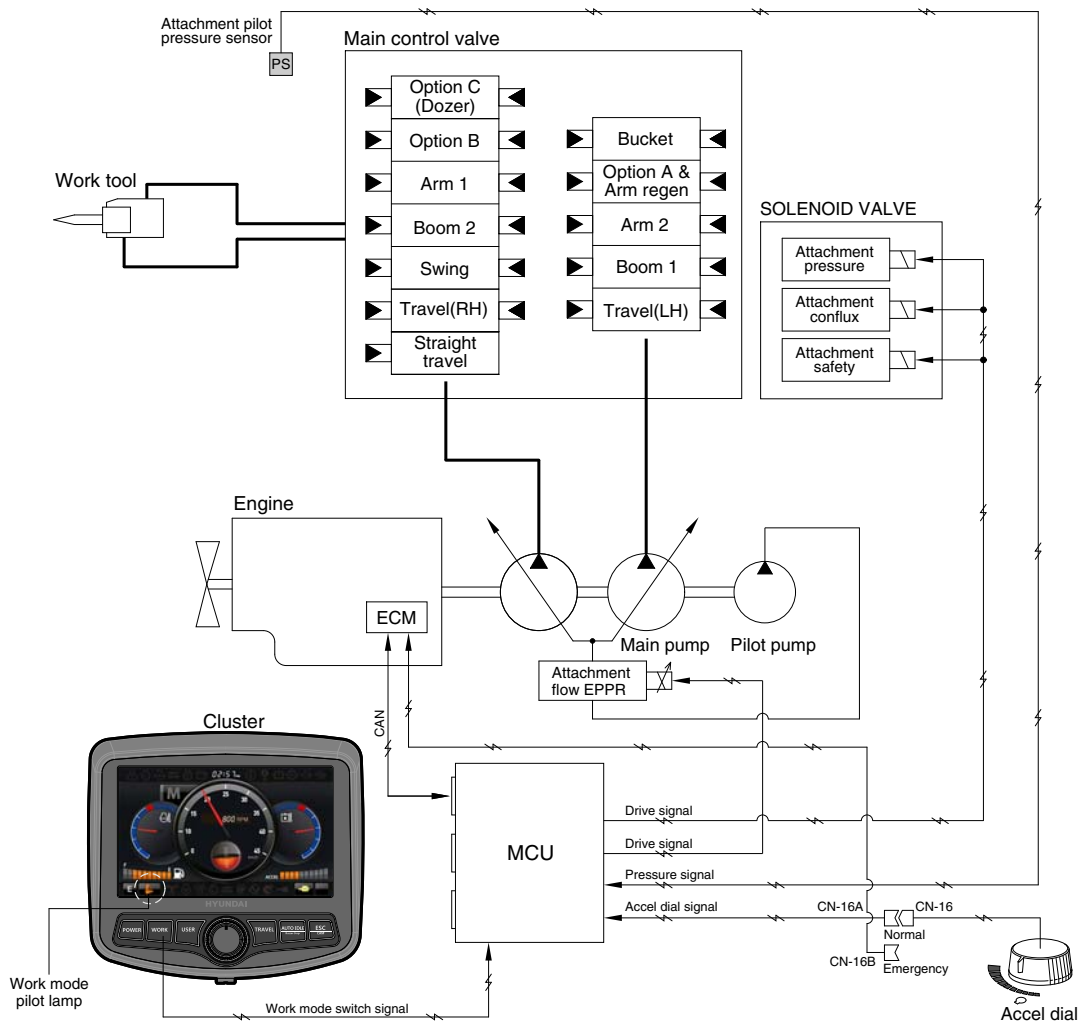

145Z9A5MS06

- The system is used to control the pump delivery flow according to set of the work tool on the cluster by the attachment flow EPPR valve.

Description	Work tool	
	Breaker	Crusher
Flow level	Max 7 step, reduced 10 lpm each step	Max 4 step, reduced 20 lpm each step
Attach safety solenoid	ON	ON
Attach pressure solenoid	OFF	ON
Attach conflux solenoid	OFF	ON/OFF

※ Refer to the page 5-38 for the attachment kinds and max flow.

GROUP 10 ANTI-RESTART SYSTEM

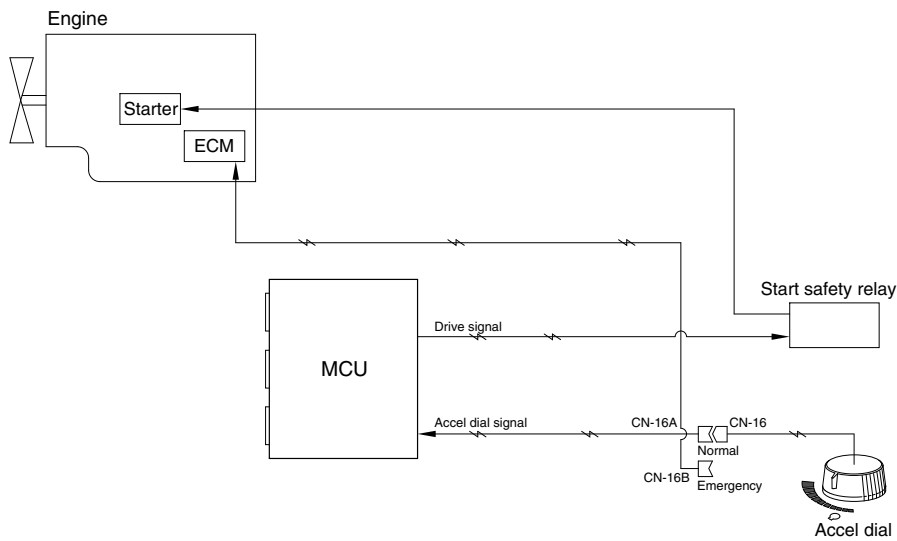

2609A5MS12

1. ANTI-RESTART FUNCTION

After a few seconds from the engine starts to run, MCU turns off the start safety relay to protect the starter from inadvertent restarting.

2. When a replacement or taking-off of the MCU is needed, connect CN-16 and CN-16B to ensure the engine start without the MCU.

GROUP 11 SELF-DIAGNOSTIC SYSTEM

1. OUTLINE

When any abnormality occurs in the ADVANCED CAPO system caused by electric parts malfunction and by open or short circuit, the MCU diagnoses the problem and sends the error codes to the cluster and also stores them in the memory.

2. MONITORING

1) Active fault



- The active faults of the MCU or engine ECM can be checked by this menu.

2) Logged fault



- The logged faults of the MCU or engine ECM can be checked by this menu.

3) Delete fault



- The logged faults of the MCU or engine ECM can be deleted by this menu.

3. MACHINE ERROR CODES TABLE

Error code		Description
HCESPN	FMI	
101	3	Hydraulic oil temperature sensor circuit - Voltage above normal, or shorted to high source.
	4	Hydraulic oil temperature circuit - Voltage below normal, or shorted to low source.
105	0	Working pressure sensor data above normal range.
	1	Working pressure sensor data below normal range.
	2	Working pressure sensor data error.
	4	Working pressure sensor circuit - Voltage below normal, or shorted to Low source.
108	0	Travel oil pressure sensor data above normal range.
	1	Travel oil pressure sensor data below normal range.
	2	Travel oil pressure sensor data error.
	4	Travel oil pressure sensor circuit - Voltage below normal, or shorted to low source.
120	0	Main pump 1 (P1) pressure sensor data above normal range.
	1	Main pump 1 (P1) pressure sensor data below normal range.
	2	Main pump 1 (P1) pressure sensor data error.
	4	Main pump 1 (P1) pressure sensor circuit - Voltage below normal, or shorted to low source.
121	0	Main pump 2 (P2) pressure sensor data above normal range.
	1	Main pump 2 (P2) pressure sensor data below normal range.
	2	Main pump 2 (P2) pressure sensor data error.
	4	Main pump 2 (P2) pressure sensor circuit - Voltage below normal, or shorted to low source.
122	0	Overload pressure sensor data above normal range.
	1	Overload pressure sensor data below normal range.
	2	Overload pressure sensor data error.
	4	Overload pressure sensor circuit - Voltage below normal, or shorted to low source.
123	0	Negative 1 pressure sensor data above normal range.
	1	Negative 1 pressure sensor data below normal range.
	2	Negative 1 pressure sensor data error.
	4	Negative 1 pressure sensor circuit - Voltage below normal, or shorted to low source.
124	0	Negative 2 Pressure sensor data above normal range.
	1	Negative 2 Pressure sensor data below normal range.
	2	Negative 2 Pressure sensor data error.
	4	Negative 2 Pressure sensor circuit - Voltage below normal, or shorted to low source.
125	0	Pilot pump (P3) pressure sensor data above normal range.
	1	Pilot pump (P3) pressure sensor data below normal range.
	2	Pilot pump (P3) pressure sensor data error.
	4	Pilot pump (P3) pressure sensor circuit - Voltage below normal, or shorted to low source.
127	0	Boom up pilot pressure sensor data above normal range.
	1	Boom up pilot pressure sensor data below normal range.
	2	Boom up pilot pressure sensor data error.
	4	Boom up pilot pressure sensor circuit - Voltage below normal, or shorted to low source.
133	0	Arm in/out & bucket in pilot pressure sensor data above normal range.
	1	Arm in/out & bucket in pilot pressure sensor data below normal range.
	2	Arm in/out & bucket in pilot pressure sensor data error.
	4	Arm in/out & bucket in pilot pressure sensor circuit - Voltage below normal, or shorted to low source.

※ Some error codes are not applied to this machine.

※ SPN : Suspect Parameter Number

FMI : Failure Mode Identifier

Error code		Description
HCESPN	FMI	
135	0	Swing pilot pressure sensor data above normal range.
	1	Swing pilot pressure sensor data below normal range.
	2	Swing pilot pressure sensor data error.
	4	Swing pilot pressure sensor circuit - Voltage below normal, or shorted to low source.
138	0	Attachment pilot pressure sensor data above normal range.
	1	Attachment pilot pressure sensor data below normal range.
	2	Attachment pilot pressure sensor data error.
	4	Attachment pilot pressure sensor circuit - Voltage below normal, or shorted to low source.
140	5	Pump EPPR valve circuit - Current below normal, or open circuit.
	6	Pump EPPR valve circuit - Current above normal.
141	5	Boom priority EPPR valve circuit - Current below normal, or open circuit.
	6	Boom priority EPPR valve circuit - Current above normal.
143	5	Travel EPPR valve circuit - Current below normal, or open circuit.
	6	Travel EPPR valve circuit - Current above normal.
144	5	Attachment flow EPPR valve circuit - Current below normal, or open circuit.
	6	Attachment flow EPPR valve circuit - Current above normal.
145	5	Remote cooling fan EPPR valve circuit - Current below normal, or open circuit.
	6	Remote cooling fan EPPR valve circuit - Current above normal.
150	5	Left rotate EPPR valve circuit - Current below normal, or open circuit.
	6	Left rotate EPPR valve circuit - Current above normal.
151	5	Right rotate EPPR valve circuit - Current below normal, or open circuit.
	6	Right rotate EPPR valve circuit - Current above normal.
152	5	Left tilt EPPR valve circuit - Current below normal, or open circuit.
	6	Left tilt EPPR valve circuit - Current above normal.
153	5	Right tilt EPPR valve circuit - Current below normal, or open circuit.
	6	Right tilt EPPR valve circuit - Current above normal.
166	5	Power max solenoid circuit - Current below normal, or open circuit.
	6	Power max solenoid circuit - Current above normal.
167	5	Travel speed solenoid circuit - Current below normal, or open circuit.
	6	Travel speed solenoid circuit - Current above normal.
168	5	Attachment pressure solenoid circuit - Current below normal, or open circuit.
	6	Attachment pressure solenoid circuit - Current above normal.
169	5	Attachment conflux solenoid circuit - Current below normal, or open circuit.
	6	Attachment conflux solenoid circuit - Current above normal.
170	5	Arm regeneration solenoid circuit - Current below normal, or open circuit.
	6	Arm regeneration solenoid circuit - Current above normal.
171	5	Attachment safety solenoid circuit - Current below normal, or open circuit.
	6	Attachment safety solenoid circuit - Current above normal.
181	5	Remote cooling fan reverse solenoid circuit - Current below normal, or open circuit.
	6	Remote cooling fan reverse solenoid circuit - Current above normal.
301	5	Fuel level sensor circuit - Voltage above normal, or shorted to high source.
	6	Fuel level sensor circuit - Voltage below normal, or shorted to low source.
304	3	Engine coolant temperature sensor circuit - Voltage above normal, or shorted to high source.
	4	Engine coolant temperature sensor circuit - Voltage below normal, or shorted to low source.
310	8	Engine speed signal error - Abnormal frequency or pulse width.
322	3	Engine preheat relay circuit - Voltage above normal, or shorted to high source.
	4	Engine preheat relay circuit - Voltage below normal, or shorted to low source.
325	3	Fuel warmer relay circuit - Voltage above normal, or shorted to high source.
	4	Fuel warmer relay circuit - Voltage below normal, or shorted to low source.

※ Some error codes are not applied to this machine.

※ SPN : Suspect Parameter Number

FMI : Failure Mode Identifier

Error code		Description
HCESPN	FMI	
340	3	Potentiometer (G/A) circuit - Voltage above normal, or shorted to high source.
	4	Potentiometer (G/A) circuit - Voltage below normal, or shorted to low source.
341	5	Governor actuator circuit - Current below normal, or open circuit.
	6	Governor actuator circuit - Current above normal.
501	0	Transmission oil pressure sensor data above normal range.
	1	Transmission oil pressure sensor data below normal range.
	2	Transmission oil pressure sensor data error.
	4	Transmission oil pressure sensor circuit - Voltage below normal, or shorted to low source.
503	0	Brake pressure sensor data above normal range.
	1	Brake pressure sensor data below normal range.
	2	Brake pressure sensor data error.
	4	Brake pressure sensor circuit - Voltage below normal, or shorted to low source.
505	0	Working brake pressure sensor data above normal range.
	1	Working brake pressure sensor data below normal range.
	2	Working brake pressure sensor data error.
	4	Working brake pressure sensor circuit - Voltage below normal, or shorted to low source.
506	3	Working brake lamp circuit - Voltage above normal, or shorted to high source.
	4	Working brake lamp circuit - Voltage below normal, or shorted to low source.
520	3	Ram lock lamp circuit - Voltage above normal, or shorted to high source.
	4	Ram lock lamp circuit - Voltage below normal, or shorted to low source.
525	5	Ram lock solenoid circuit - Current below normal, or open circuit.
	6	Ram lock solenoid circuit - Current above normal.
530	0	Travel F pilot pressure sensor data above normal range.
	1	Travel F pilot pressure sensor data below normal range.
	2	Travel F pilot pressure sensor data error.
	4	Travel F pilot pressure sensor circuit - Voltage below normal, or shorted to low source.
531	0	Travel R pilot pressure sensor data above normal range.
	1	Travel R pilot pressure sensor data below normal range.
	2	Travel R pilot pressure sensor data error.
	4	Travel R pilot pressure sensor circuit - Voltage below normal, or shorted to low source.
701	3	Hourmeter circuit - Voltage above normal, or shorted to high source.
	4	Hourmeter circuit - Voltage below normal, or shorted to low source.
705	0	MCU input voltage high.
	1	MCU input voltage low.
707	1	Alternator node I voltage low.
714	3	Acc. dial circuit - Voltage above normal, or shorted to high source.
	4	Acc. dial circuit - Voltage below normal, or shorted to low source.
715	3	Rotate signal input circuit - Voltage above normal, or shorted to high source.
	4	Rotate signal input circuit - Voltage below normal, or shorted to low source.
716	3	Tilt signal input circuit - Voltage above normal, or shorted to high source.
	4	Tilt signal input circuit - Voltage below normal, or shorted to low source.
722	3	Travel alarm (buzzer) circuit - Voltage above normal, or shorted to high source.
	4	Travel alarm (buzzer) circuit - Voltage below normal, or shorted to low source.
830	12	MCU internal memory error.
840	2	Cluster communication data error.
841	2	ECM communication data error.
843	2	Option #1 (CAN 2) communication data error.
850	2	RMCU communication data error.

※ Some error codes are not applied to this machine.

※ SPN : Suspect Parameter Number

FMI : Failure Mode Identifier

4. ENGINE FAULT CODE

J1939 Code	Description	Refer to Procedure
27-3	Engine Exhaust Gas Recirculation Valve Position Sensor : Voltage Above Normal	Valve Position Sensor - Test
27-4	Engine Exhaust Gas Recirculation Valve Position Sensor : Voltage Below Normal	Valve Position Sensor - Test
29-2	Accelerator Pedal Position 2 : Erratic, Intermittent, or Incorrect (Engines equipped with a throttle switch)	Throttle Switch Circuit - Test
29-2	Accelerator Pedal Position 2 : Erratic, Intermittent or Incorrect (Engines equipped with an analog throttle)	Analog Throttle Position Sensor Circuit - Test
29-3	Accelerator Pedal Position 2 : Voltage Above Normal (Engines equipped with an analog throttle)	Analog Throttle Position Sensor Circuit - Test
29-3	Accelerator Pedal Position 2 : Voltage Above Normal (Engines equipped with a digital throttle)	Digital Throttle Position Sensor Circuit - Test
29-4	Accelerator Pedal Position 2 : Voltage Below Normal (Engines equipped with an analog throttle)	Analog Throttle Position Sensor Circuit - Test
29-4	Accelerator Pedal Position 2 : Voltage Below Normal (Engines equipped with a digital throttle)	Digital Throttle Position Sensor Circuit - Test
29-8	Accelerator Pedal Position 2 : Abnormal Frequency, Pulse Width or Period	Digital Throttle Position Sensor Circuit - Test
91-2	Accelerator Pedal Position 1 : Erratic, Intermittent, or Incorrect (Engines equipped with a throttle switch)	Throttle Switch Circuit - Test
91-2	Accelerator Pedal Position 1 : Erratic, Intermittent or Incorrect (Engines equipped with an analog throttle)	Analog Throttle Position Sensor Circuit - Test
91-3	Accelerator Pedal Position 1 : Voltage Above Normal (Engines equipped with an analog throttle)	Analog Throttle Position Sensor Circuit - Test
91-3	Accelerator Pedal Position 1 : Voltage Above Normal (Engines equipped with a digital throttle)	Digital Throttle Position Sensor Circuit - Test
91-4	Accelerator Pedal Position 1 : Voltage Below Normal (Engines equipped with an analog throttle)	Analog Throttle Position Sensor Circuit - Test
91-4	Accelerator Pedal Position 1 : Voltage Below Normal (Engines equipped with a digital throttle)	Digital Throttle Position Sensor Circuit - Test
91-8	Accelerator Pedal Position 1 : Abnormal Frequency, Pulse Width or Period	Digital Throttle Position Sensor Circuit - Test
97-15	Water In Fuel Indicator : High - least severe (1)	Fuel System Water Separator Has Water
97-16	Water In Fuel Indicator : High - moderate severity (2)	Fuel System Water Separator Has Water
100-1	Engine Oil Pressure : Low - most severe (3)	Low Engine Oil Pressure
100-3	Engine Oil Pressure : Voltage Above Normal	Engine Pressure Sensor Open or Short Circuit - Test
100-4	Engine Oil Pressure : Voltage Below Normal	Engine Pressure Sensor Open or Short Circuit - Test
100-17	Engine Oil Pressure : Low - least severe (1)	Low Engine Oil Pressure
100-21	Engine Oil Pressure : Data Drifted Low	5 V Sensor Supply Circuit - Test
102-16	Engine Intake Manifold #1 Pressure : High - moderate severity (2)	Intake Manifold Air Pressure Is High
102-18	Engine Intake Manifold #1 Pressure : Low - moderate severity (2)	Intake Manifold Air Pressure Is Low

J1939 Code	Description	Refer to Procedure
105-3	Engine Intake Manifold #1 Temperature : Voltage Above Normal	Engine Temperature Sensor Open or Short Circuit - Test (Passive Sensors)
105-4	Engine Intake Manifold #1 Temperature : Voltage Below Normal	Engine Temperature Sensor Open or Short Circuit - Test (Passive Sensors)
105-15	Engine Intake Manifold #1 Temperature : High - least severe (1)	Intake Manifold Air Temperature Is High
105-16	Engine Intake Manifold #1 Temperature : High - moderate severity (2)	Intake Manifold Air Temperature Is High
107-15	Engine Air Filter 1 Differential Pressure : High - least severe (1)	Inlet Air Is Restricted
108-3	Barometric Pressure : Voltage Above Normal	Engine Pressure Sensor Open or Short Circuit - Test
108-4	Barometric Pressure : Voltage Below Normal	Engine Pressure Sensor Open or Short Circuit - Test
108-21	Barometric Pressure : Data Drifted Low	5 V Sensor Supply Circuit - Test
110-0	Engine Coolant Temperature : High - most severe (3)	Coolant Temperature Is Too High
110-3	Engine Coolant Temperature : Voltage Above Normal	Engine Temperature Sensor Open or Short Circuit - Test (Passive Sensors)
110-4	Engine Coolant Temperature : Voltage Below Normal	Engine Temperature Sensor Open or Short Circuit - Test (Passive Sensors)
110-15	Engine Coolant Temperature : High - least severe (1)	Coolant Temperature Is Too High
110-16	Engine Coolant Temperature : High - moderate severity (2)	Coolant Temperature Is Too High
111-1	Engine Coolant Level : Low - most severe (3)	Coolant Level Is Low
157-3	Engine Injector Metering Rail #1 Pressure : Voltage Above Normal	Engine Pressure Sensor Open or Short Circuit - Test
157-4	Engine Injector Metering Rail #1 Pressure : Voltage Below Normal	Engine Pressure Sensor Open or Short Circuit - Test
157-15	Engine Injector Metering Rail #1 Pressure : High - least severe (1)	Fuel Rail Pressure Problem
157-17	Engine Injector Metering Rail #1 Pressure : Low - least severe (1)	Fuel Rail Pressure Problem
168-2	Battery Potential / Power Input 1 : Erratic, Intermittent or Incorrect	Ignition Keyswitch Circuit and Battery Supply Circuit - Test
168-3	Battery Potential / Power Input 1 : Voltage Above Normal	Ignition Keyswitch Circuit and Battery Supply Circuit - Test
168-4	Battery Potential / Power Input 1 : Voltage Below Normal	Ignition Keyswitch Circuit and Battery Supply Circuit - Test
172-3	Engine Air Inlet Temperature : Voltage Above Normal	Engine Temperature Sensor Open or Short Circuit - Test (Passive Sensors)
172-4	Engine Air Inlet Temperature : Voltage Below Normal	Engine Temperature Sensor Open or Short Circuit - Test (Passive Sensors)
174-3	Engine Fuel Temperature 1 : Voltage Above Normal	Engine Temperature Sensor Open or Short Circuit - Test (Passive Sensors)
174-4	Engine Fuel Temperature 1 : Voltage Below Normal	Engine Temperature Sensor Open or Short Circuit - Test (Passive Sensors)

J1939 Code	Description	Refer to Procedure
174-15	Engine Fuel Temperature 1 : High - least severe (1)	Fuel Temperature Is High
174-16	Engine Fuel Temperature 1 : High - moderate severity (2)	Fuel Temperature Is High
190-8	Engine Speed : Abnormal Frequency, Pulse Width or Period	Engine Speed/Timing Sensor Circuit - Test
190-15	Engine Speed : High - least severe (1)	Engine Overspeeds
412-3	Engine Exhaust Gas Recirculation Temperature : Voltage Above Normal	Engine Temperature Sensor Open or Short Circuit - Test (Passive Sensors)
412-4	Engine Exhaust Gas Recirculation Temperature : Voltage Below Normal	Engine Temperature Sensor Open or Short Circuit - Test (Passive Sensors)
412-15	Engine Exhaust Gas Recirculation Temperature : High - least severe (1)	NRS Exhaust Gas Temperature Is High
412-16	Engine Exhaust Gas Recirculation Temperature : High - moderate severity (2)	NRS Exhaust Gas Temperature Is High
558-2	Accelerator Pedal 1 Low Idle Switch : Erratic, Intermittent or Incorrect	Idle Validation Switch Circuit - Test
626-5	Engine Start Enable Device 1 : Current Below Normal	Ether Starting Aid - Test
626-6	Engine Start Enable Device 1 : Current Above Normal	Ether Starting Aid - Test
630-2	Calibration Memory : Erratic, Intermittent or Incorrect	Flash Programming
631-2	Calibration Module : Erratic, Intermittent or Incorrect	ECM Memory - Test
637-11	Engine Timing Sensor : Other Failure Mode	Engine Speed/Timing Sensor Circuit - Test
639-9	J1939 Network #1 : Abnormal Update Rate	CAN Data Link Circuit - Test
649-3	Engine Exhaust Back Pressure Regulator Solenoid : Voltage Above Normal	Motorized Valve - Test
649-5	Engine Exhaust Back Pressure Regulator Solenoid : Current Below Normal	Motorized Valve - Test
649-6	Engine Exhaust Back Pressure Regulator Solenoid : Current Above Normal	Motorized Valve - Test
649-7	Engine Exhaust Back Pressure Regulator Solenoid : Not Responding Properly	Motorized Valve - Test
651-2	Engine Injector Cylinder #01 : Erratic, Intermittent or Incorrect	Injector Data Incorrect - Test
651-5	Engine Injector Cylinder #01 : Current Below Normal	Injector Solenoid Circuit - Test
651-6	Engine Injector Cylinder #01 : Current Above Normal	Injector Solenoid Circuit - Test
652-2	Engine Injector Cylinder #02 : Erratic, Intermittent or Incorrect	Injector Data Incorrect - Test
652-5	Engine Injector Cylinder #02 : Current Below Normal	Injector Solenoid Circuit - Test
652-6	Engine Injector Cylinder #02 : Current Above Normal	Injector Solenoid Circuit - Test
653-2	Engine Injector Cylinder #03 : Erratic, Intermittent or Incorrect	Injector Data Incorrect - Test

J1939 Code	Description	Refer to Procedure
653-5	Engine Injector Cylinder #03 : Current Below Normal	Injector Solenoid Circuit - Test
653-6	Engine Injector Cylinder #03 : Current Above Normal	Injector Solenoid Circuit - Test
654-2	Engine Injector Cylinder #04 : Erratic, Intermittent or Incorrect	Injector Data Incorrect - Test
654-5	Engine Injector Cylinder #04 : Current Below Normal	Injector Solenoid Circuit - Test
654-6	Engine Injector Cylinder #04 : Current Above Normal	Injector Solenoid Circuit - Test
655-2	Engine Injector Cylinder #05 : Erratic, Intermittent or Incorrect (1206E-E66 Engine Only)	Injector Data Incorrect - Test
655-5	Engine Injector Cylinder #05 : Current Below Normal (1206E-E66 Engine Only)	Injector Solenoid Circuit - Test
655-6	Engine Injector Cylinder #05 : Current Above Normal (1206E E66 Engine Only)	Injector Solenoid Circuit - Test
656-2	Engine Injector Cylinder #06 : Erratic, Intermittent or Incorrect (1206E-E66 Engine Only)	Injector Data Incorrect - Test
656-5	Engine Injector Cylinder #06 : Current Below Normal (1206E-E66 Engine Only)	Injector Solenoid Circuit - Test
656-6	Engine Injector Cylinder #06 : Current Above Normal (1206E-E66 Engine Only)	Injector Solenoid Circuit - Test
676-6	Engine Glow Plug Relay : Current Above Normal	Starting Aid (Glow Plug) Relay Circuit - Test
678-3	ECU 8 Volts DC Supply : Voltage Above Normal	Digital Throttle Position Sensor Circuit - Test
678-4	ECU 8 Volts DC Supply : Voltage Below Normal	Digital Throttle Position Sensor Circuit - Test
723-8	Engine Speed Sensor #2 : Abnormal Frequency, Pulse Width or Period	Engine Speed/Timing Sensor Circuit - Test
1075-5	Engine Electric Lift Pump For Engine Fuel Supply : Current Below Normal	Fuel Pump Relay Circuit - Test
1075-6	Engine Electric Lift Pump For Engine Fuel Supply : Current Above Normal	Fuel Pump Relay Circuit - Test
1076-5	Engine Fuel Injection Pump Fuel Control Valve : Current Below Normal	Solenoid Valve - Test
1076-6	Engine Fuel Injection Pump Fuel Control Valve : Current Above Normal	Solenoid Valve - Test
1188-3	Engine Turbocharger 1 Wastegate Drive : Voltage Above Normal	Solenoid Valve - Test
1188-5	Engine Turbocharger 1 Wastegate Drive : Current Below Normal	Solenoid Valve - Test
1188-6	Engine Turbocharger 1 Wastegate Drive : Current Above Normal	Solenoid Valve - Test
1196-9	Anti-theft Component Status States : Abnormal Update Rate	Data Link Circuit - Test
1239-0	Engine Fuel Leakage 1: High - most severe (3)	Fuel Rail Pressure Problem
2659-15	Engine Exhaust Gas Recirculation (EGR) Mass Flow Rate : High - least severe (1)	TBA
2791-3	Engine Exhaust Gas Recirculation (EGR) Valve Control : Voltage Above Normal	Motorized Valve - Test

J1939 Code	Description	Refer to Procedure
2791-5	Engine Exhaust Gas Recirculation (EGR) Valve Control : Current Below Normal	Motorized Valve - Test
2791-6	Engine Exhaust Gas Recirculation (EGR) Valve Control : Current Above Normal	Motorized Valve - Test
2791-7	Engine Exhaust Gas Recirculation (EGR) Valve Control : Not Responding Properly	Motorized Valve - Test
2882-2	Engine Alternate Rating Select : Erratic, Intermittent, or Incorrect	Mode Selection Circuit - Test
2970-2	Accelerator Pedal 2 Low Idle Switch : Erratic, Intermittent, or Incorrect	Idle Validation Switch Circuit - Test
3242-3	Particulate Trap Intake Gas Temperature : Voltage Above Normal	Engine Temperature Sensor Open or Short Circuit - Test (Active Sensors)
3242-4	Particulate Trap Intake Gas Temperature : Voltage Below Normal	Engine Temperature Sensor Open or Short Circuit - Test (Active Sensors)
3242-17	Particulate Trap Intake Gas Temperature : Low - least severe (1)	Diesel Particulate Filter Temperature Is High
3242-18	Particulate Trap Intake Gas Temperature : Low - moderate severity (2)	Diesel Particulate Filter Temperature Is Low
3358-3	Engine Exhaust Gas Recirculation Inlet Pressure : Voltage Above Normal	Engine Pressure Sensor Open or Short Circuit - Test
3358-4	Engine Exhaust Gas Recirculation Inlet Pressure : Voltage Below Normal	Engine Pressure Sensor Open or Short Circuit - Test
3358-13	Engine Exhaust Gas Recirculation Inlet Pressure : Calibration Required	Sensor Calibration Required - Test
3358-21	Engine Exhaust Gas Recirculation Inlet Pressure : Data Drifted Low	5 V Sensor Supply Circuit - Test
3509-3	Sensor Supply Voltage 1 : Voltage Above Normal	5 V Sensor Supply Circuit - Test
3509-4	Sensor Supply Voltage 1 : Voltage Below Normal	5 V Sensor Supply Circuit - Test
3510-3	Sensor Supply Voltage 2 : Voltage Above Normal	5 V Sensor Supply Circuit - Test
3510-4	Sensor Supply Voltage 2 : Voltage Below Normal	5 V Sensor Supply Circuit - Test
3563-3	Engine Intake Manifold #1 Absolute Pressure : Voltage Above Normal	Engine Pressure Sensor Open or Short Circuit - Test
3563-4	Engine Intake Manifold #1 Absolute Pressure : Voltage Below Normal	Engine Pressure Sensor Open or Short Circuit - Test
3563-13	Engine Intake Manifold #1 Absolute Pressure : Calibration Required	Sensor Calibration Required - Test
3563-21	Engine Intake Manifold #1 Absolute Pressure : Data Drifted Low	5 V Sensor Supply Circuit - Test
3719-0	Particulate Trap #1 Soot Load Percent : High - most severe (3)	Diesel Particulate Filter Collects Excessive Soot
3719-16	Particulate Trap #1 Soot Load Percent : High - moderate severity (2)	Diesel Particulate Filter Collects Excessive Soot
4783-3	Diesel Particulate Filter #1 Mean Soot Signal : Voltage Above Normal	Soot Sensor - Test
4783-4	Diesel Particulate Filter #1 Mean Soot Signal : Voltage Below Normal	Soot Sensor - Test

J1939 Code	Description	Refer to Procedure
4783-9	Diesel Particulate Filter #1 Mean Soot Signal : Abnormal Update Rate	Soot Sensor - Test
4783-12	Diesel Particulate Filter #1 Mean Soot Signal : Failure	Soot Sensor - Test
4783-13	Diesel Particulate Filter #1 Mean Soot Signal : Calibration Required	Soot Sensor - Test
4783-19	Diesel Particulate Filter #1 Mean Soot Signal : Data Error	Soot Sensor - Test
4783-21	Diesel Particulate Filter #1 Mean Soot Signal : Data Drifted Low	Soot Sensor - Test
5019-3	Engine Exhaust Gas Recirculation Outlet Pressure : Voltage Above Normal	Engine Pressure Sensor Open or Short Circuit - Test
5019-4	Engine Exhaust Gas Recirculation Outlet Pressure : Voltage Below Normal	Engine Pressure Sensor Open or Short Circuit - Test
5019-13	Engine Exhaust Gas Recirculation Outlet Pressure : Calibration Required	Sensor Calibration Required - Test
5019-21	Engine Exhaust Gas Recirculation Outlet Pressure : Data Drifted Low	5 V Sensor Supply Circuit - Test
5571-0	High Pressure Common Rail Fuel Pressure Relief Valve : Active	Fuel Rail Pressure Problem
5576-2	Aftertreatment #1 Identification Number Module : Erratic, Intermittent or incorrect	Diesel Particulate Filter Identification Signal - Test
5576-8	Aftertreatment #1 Identification Number Module : Abnormal Frequency, Pulse Width, or Period	Diesel Particulate Filter Identification Signal - Test
5576-14	Aftertreatment #1 Identification Number Module : Special Instruction	Diesel Particulate Filter Identification Signal - Test
5625-3	Exhaust Back Pressure Regulator Position : Voltage Above Normal	Valve Position Sensor - Test
5625-4	Exhaust Back Pressure Regulator Position : Voltage Below Normal	Valve Position Sensor - Test
5629-31	Particulate Trap Active Regeneration Inhibited Due To Low Exhaust Gas Pressure - least severe (1)	Diesel Particulate Filter Collects Excessive Soot

GROUP 12 ENGINE CONTROL SYSTEM

1. MCU and Engine ECM (Electronic Control Module)

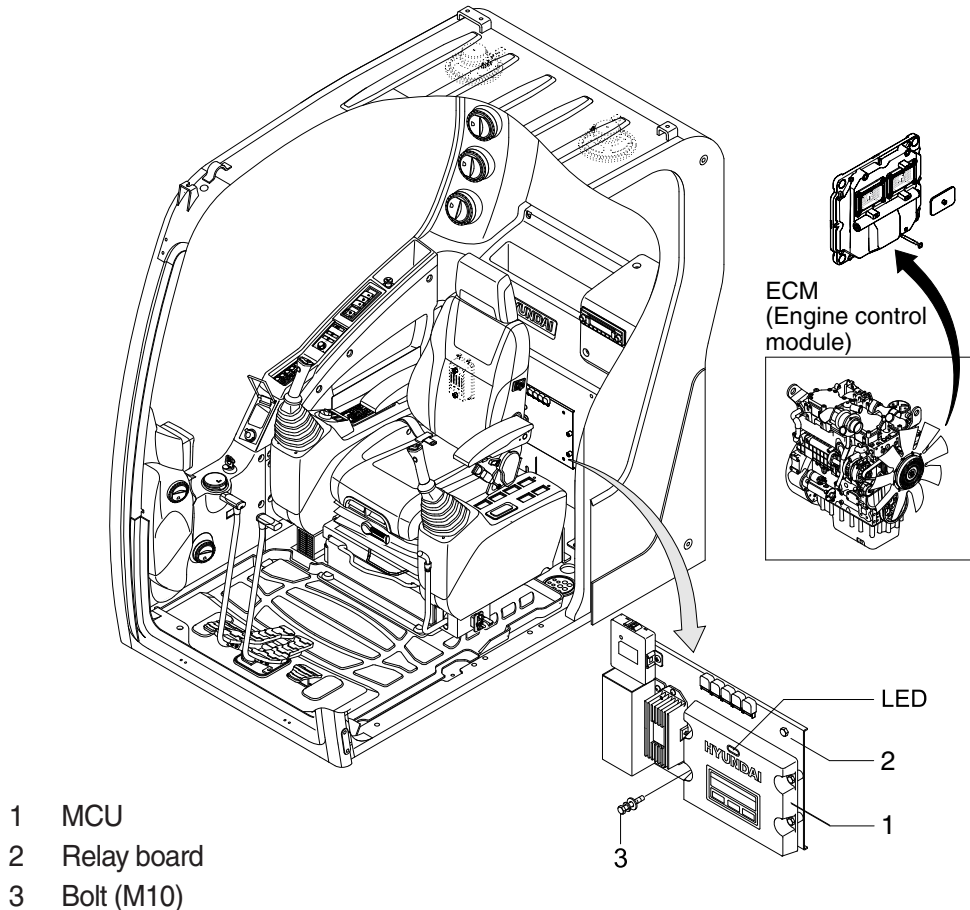

145Z9A5MS07

2. MCU ASSEMBLY

1) To match the pump absorption torque with the engine torque, MCU varies EPPR valve output pressure, which control pump discharge amount whenever feedbacked engine speed drops under the reference rpm of each mode set.

2) Three LED lamps on the MCU display as below.

LED lamp	Trouble	Service
G is turned ON	Normal	-
G and R are turned ON	Trouble on MCU	• Change the MCU
G and Y are turned ON	Trouble on serial communication line	• Check if serial communication lines between controller and cluster are disconnected
Three LED are turned OFF	Trouble on MCU power	• Check if the input power wire (24 V, GND) of controller is disconnected • Check the fuse

G : green, R : red, Y : yellow

GROUP 13 EPPR VALVE

1. PUMP EPPR VALVE

1) COMPOSITION

EPPR (Electro Proportional Pressure Reducing) valve consists of electro magnet and spool valve installed at main pump.

(1) Electro magnet valve

Receive electric current from MCU and move the spool proportionally according to the specific amount of electric current value.

(2) Spool valve

Is the two way direction control valve for pilot pressure to reduce main pump flow.

When the electro magnet valve is activated, pilot pressure enters into flow regulator of main pump.

(3) Pressure and electric current value for each mode

Mode		Pressure		Electric current (mA)	Engine rpm (at accel dial 10)
		kgf/cm ²	psi		
Standard (Stage : 1.0)	P	10	142	290 ± 30	1850 ± 50
	S	13 ± 3	185 ± 40	360 ± 30	1750 ± 50
	E	15 ± 3	213 ± 40	365 ± 30	1650 ± 50
Option (Stage : 2.0)	P	0	0	160 ± 30	2100 ± 50
	S	5 ± 3	71 ± 40	250 ± 30	2000 ± 50
	E	10 ± 3	142 ± 40	280 ± 30	1750 ± 50

2) HOW TO SWITCH THE STAGE (1.0 ↔ 2.0) ON THE CLUSTER

You can switch the EPPR valve pressure set by selecting the stage (1.0 ↔ 2.0).

- Management
 - Service menu

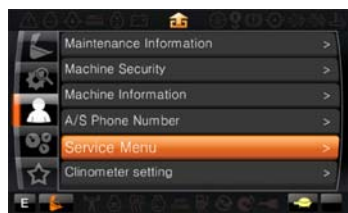

Enter the password



- Power shift (standard/option) : Power shift pressure can be set by option menu.

3) OPERATING PRINCIPLE (pump EPPR valve)

(1) Structure

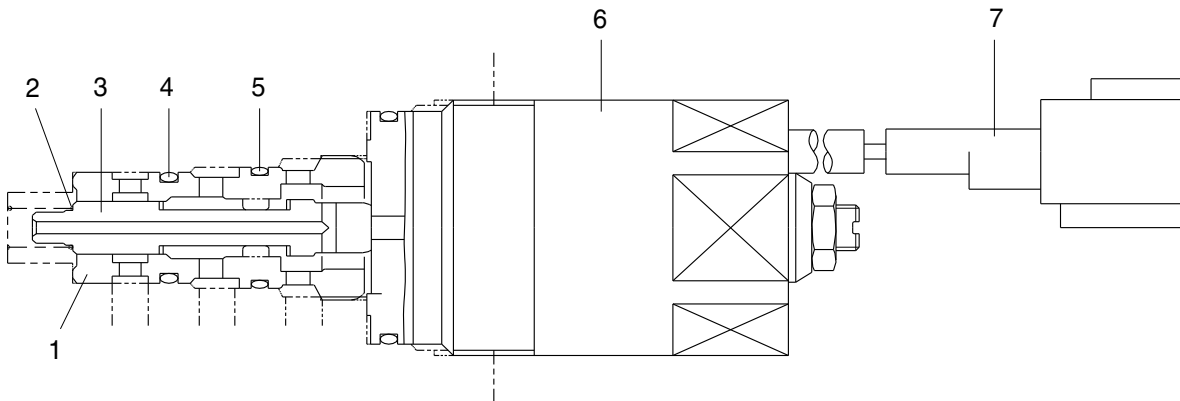

5-22(1)

- 1 Sleeve
- 2 Spring
- 3 Spool

- 4 O-ring
- 5 O-ring

- 6 Solenoid valve
- 7 Connector

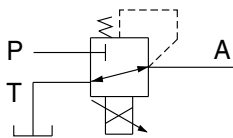

P Pilot oil supply line (pilot pressure)

T Return to tank

A Secondary pressure to flow regulator at main pump

(2) Neutral

Pressure line is blocked and A oil returns to tank.

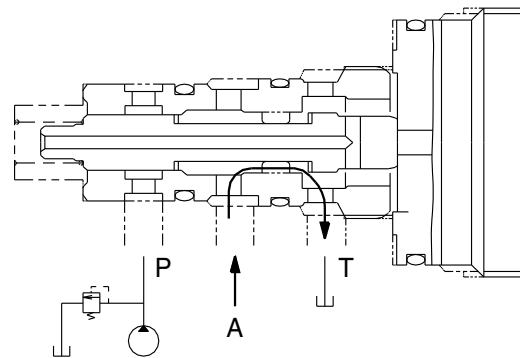
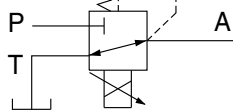

(3) Operating

Secondary pressure enters into A.

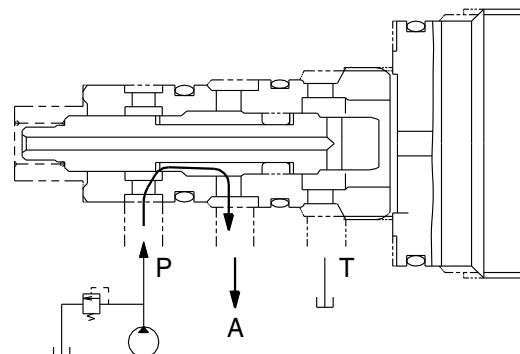
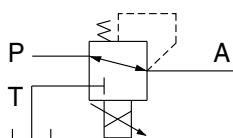

5-22(2)

4) EPPR VALVE CHECK PROCEDURE

(1) Check electric current value at EPPR valve

- ① Disconnect connector CN-75 from EPPR valve.
- ② Insert the adapter to CN-75 and install multimeter as figure.
- ③ Start engine.
- ④ Set S-mode and cancel auto decel mode.
- ⑤ Position the accel dial at 10.
- ⑥ If rpm display show approx 1750 ± 50 rpm check electric current at bucket circuit relief position.

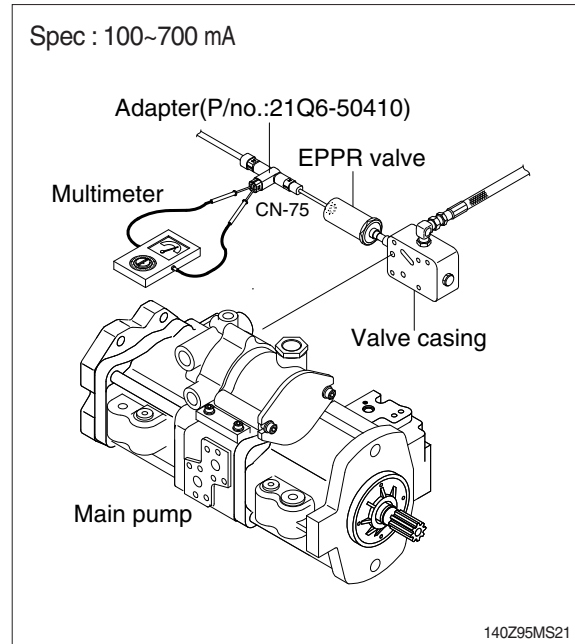

(2) Check pressure at EPPR valve

- ① Remove plug and connect pressure gauge as figure.
 - Gauge capacity : 0 to 50 kgf/cm² (0 to 725 psi)
- ② Start engine.
- ③ Set S-mode and cancel auto decel mode.
- ④ Position the accel dial at 10.
- ⑤ If rpm display approx 1750 ± 50 rpm check pressure at relief position of bucket circuit by operating bucket control lever.
- ⑥ If pressure is not correct, adjust it.
- ⑦ After adjust, test the machine.

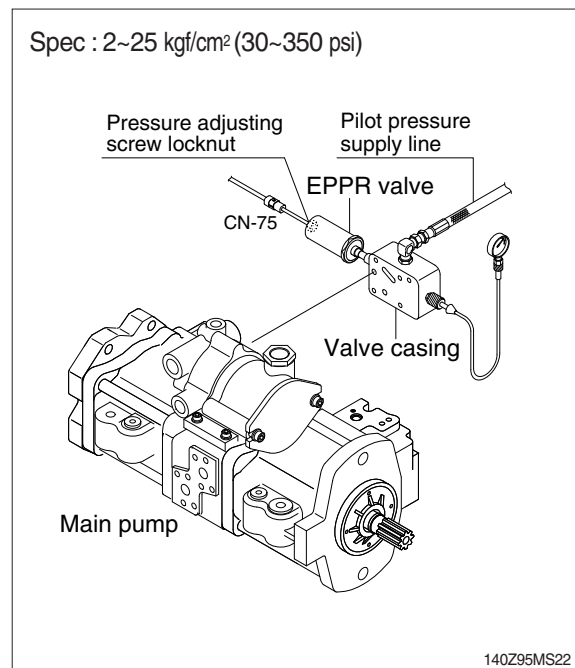

2. BOOM PRIORITY EPPR VALVE

1) COMPOSITION

The boom priority EPPR valve is built in a manifold and mainly consisting of valve body and coil. This EPPR valve installed under the solenoid valve.

2) CONTROL

The boom priority EPPR valve has to be controlled by a specific electronic amplifier card, which is supplying the coil with a current 580 mA at 30 Ω and 24 V.

3) OPERATING PRINCIPLE

(1) Structure

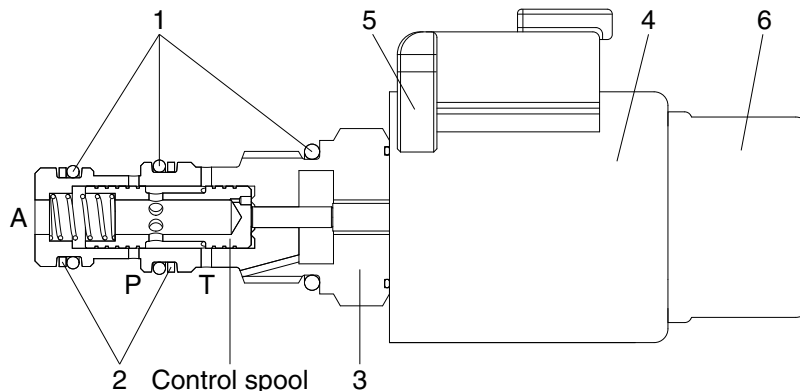

21095MS14

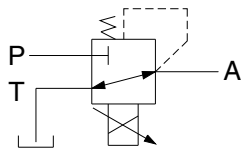

P : Pilot supply line
 T : Return to tank
 A : Secondary pressure to flow MCV

- | | | |
|----------------|--------------|-------------|
| 1 O-ring | 3 Valve body | 5 Connector |
| 2 Support ring | 4 Coil | 6 Cover cap |

(2) Operation

In de-energized mode the inlet port (P) is closed and the outlet port (A) is connected to tank port (T).

In energized mode the solenoid armature presses onto the control spool with a force corresponding to the amount of current. This will set a reduced pressure at port A. The setting is proportional to the amount of current applied.

(3) Maximum pressure relief

If a pressure from outside is applied on port A the valve may directly switch to tank port (T) and protect the system before overload.

2) EPPR VALVE CHECK PROCEDURE

(1) Check electric current value at EPPR valve

- ① Disconnect connector CN-133 from EPPR valve.
- ② Insert the adapter to CN-133 and install multimeter as figure.
- ③ Start engine.
- ④ If rpm display approx 1750 ± 50 rpm check electric current in case of combined boom up and swing operation.

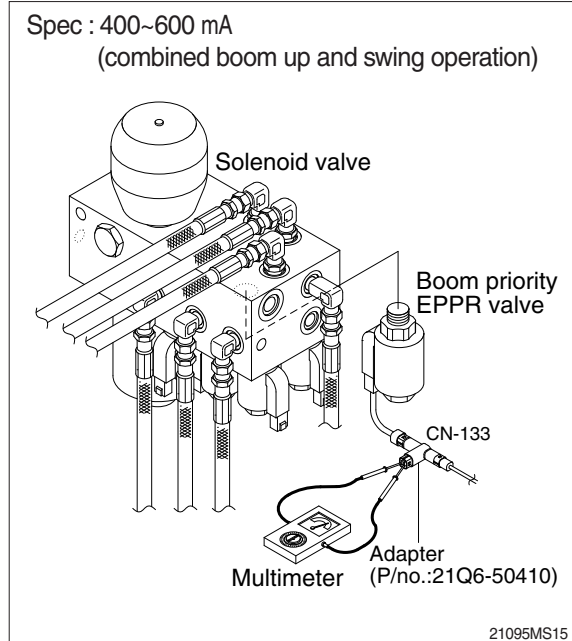

(2) Check pressure at EPPR valve

- ① Remove hose from A5 port and connect pressure gauge as figure.
 - Gauge capacity : 0 to 50 kgf/cm² (0 to 725 psi)
- ② Start engine.
- ③ If rpm display approx 1750 ± 50 rpm check pressure at relief position of bucket circuit by operating bucket control lever.
- ④ If pressure is not correct, adjust it.
- ⑤ After adjust, test the machine.

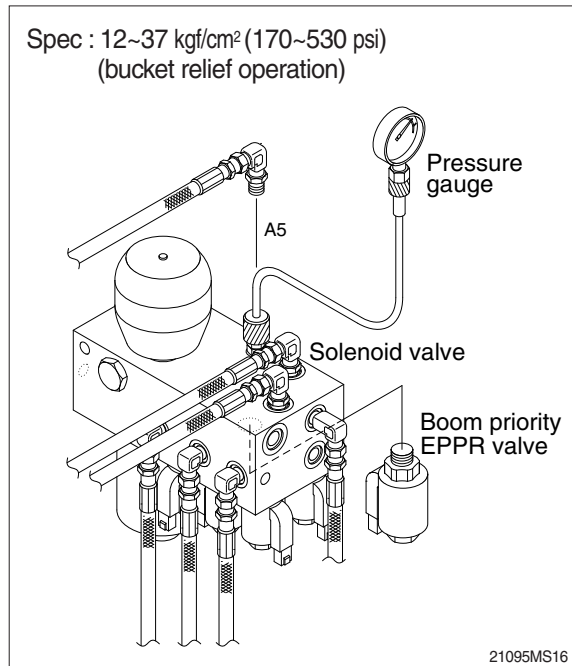

GROUP 14 MONITORING SYSTEM

1. OUTLINE

Monitoring system consists of the monitor part and switch part.

The monitor part gives warnings when any abnormality occurs in the machine and informs the condition of the machine.

Various select switches are built into the monitor panel, which act as the control portion of the machine control system.

2. CLUSTER

1) MONITOR PANEL

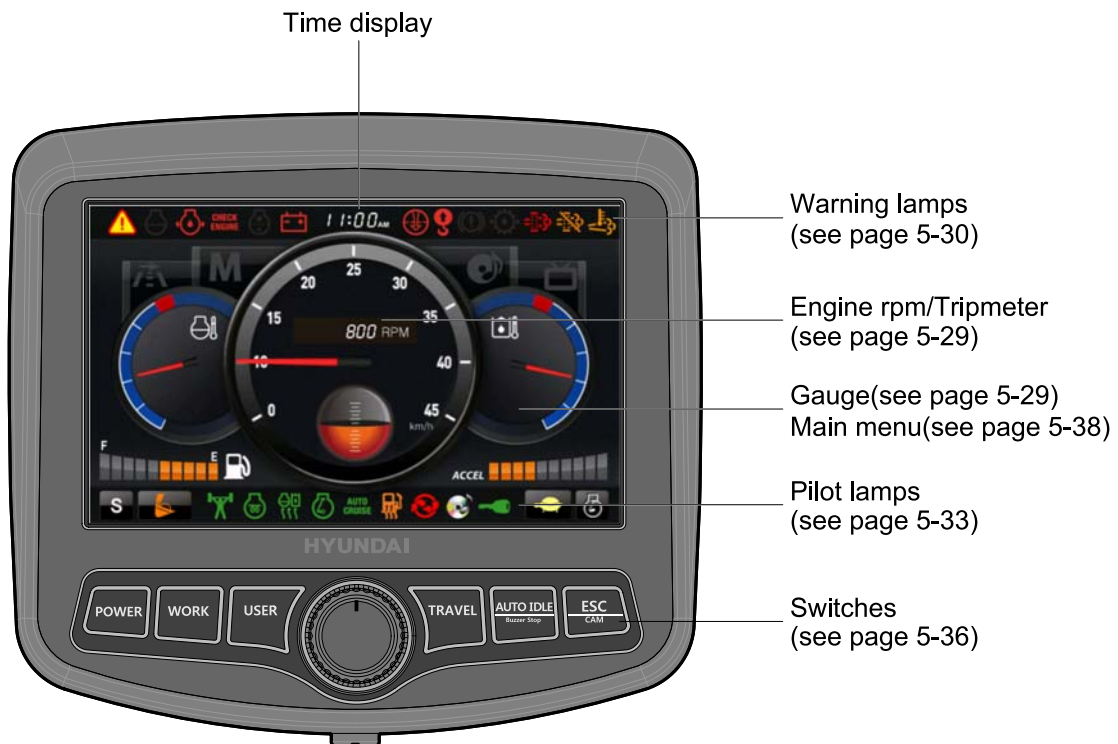

145Z9A5MS14

※ The warning lamp pops up and/or blinks and the buzzer sounds when the machine has a problem.

The warning lamp blinks until the problem is cleared. Refer to page 5-49 for details.

※ This cluster is adjustable.

- Vertical (forward/backward) : each 15°
- Horizontal (left only) : 15°

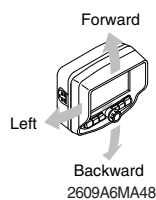

2) CLUSTER CHECK PROCEDURE

(1) Start key : ON

① Check monitor

- a. Buzzer sounding for 4 seconds with HYUNDAI logo on cluster.
- ※ If the ESL mode is set to the enable, enter the password to start engine.

② After initialization of cluster, the operating screen is displayed on the LCD.

Also, self diagnostic function is carried out.

- a. Engine rpm display : 0 rpm
- b. Engine coolant temperature gauge : White range
- c. Hydraulic oil temperature gauge : White range
- d. Fuel level gauge : White range

③ Indicating lamp state

- a. Power mode pilot lamp : E mode or U mode
- b. Work mode pilot lamp : General operation mode (bucket)
- c. Travel speed pilot lamp : Low (turtle)

(2) Start of engine

① Check machine condition

- a. RPM display indicates at present rpm
- b. Gauge and warning lamp : Indicate at present condition.
- ※ When normal condition : All warning lamp OFF
- c. Work mode selection : General work
- d. Power mode selection : E mode or U mode
- e. Travel speed pilot lamp : Low (turtle)

② When warming up operation

- a. Warming up pilot lamp : ON
- b. After engine started, engine speed increases to 1200 rpm.
- ※ Others same as above.

③ When abnormal condition

- a. The warning lamp lights up and the buzzer sounds.
- b. If BUZZER STOP switch is pressed, buzzer sound is canceled but the lamp warning lights up until normal condition.
- ※ The pop-up warning lamp moves to the original position and blink when the select switch is pushed. Also the buzzer stops.

3. CLUSTER CONNECTOR

No.	Name	Signal
1	Battery 24V	20~32V
2	Camera signal 3	NTSC
3	GND	-
4	Serial + (TX)	0~5V
5	Power IG (24V)	20~32V
6	Camera signal 2	NTSC
7	Camera signal 1	NTSC
8	Serial - (RX)	0~5V

※ NTSC : the united states National
Television System Committee

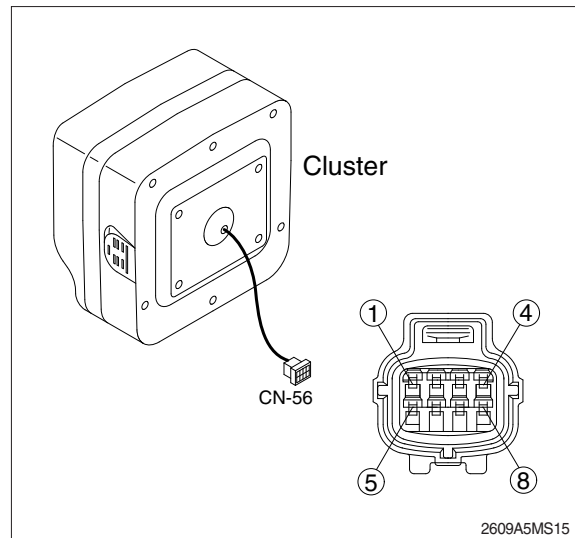

2) GAUGE

(1) Operation screen

When you first turn starting switch ON, the operation screen will appear.

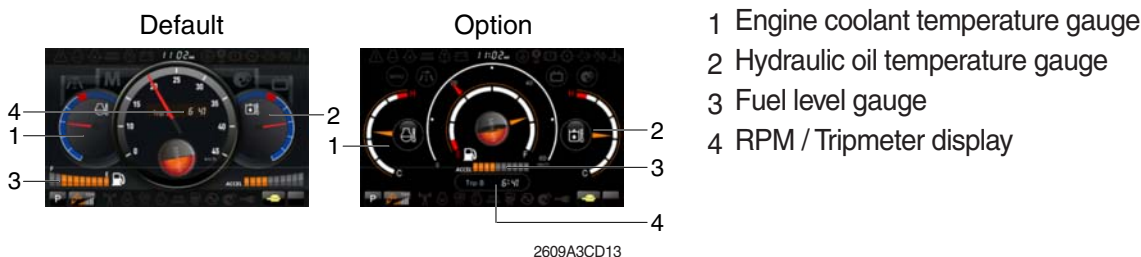

※ Operation screen type can be set by the screen type menu of the display.

Refer to page 5-46 for details.

(2) Engine coolant temperature gauge

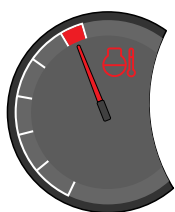

2609A3CD14

① This gauge indicates the temperature of coolant.

- White range : 40-107°C (104-225°F)
- Red range : Above 107°C (225°F)

② If the indicator is in the red range or  lamp blinks in red, turn OFF the engine and check the engine cooling system.

※ If the gauge indicates the red range or  lamp blinks in red even though the machine is on the normal condition, check the electric device as that can be caused by the poor connection of electricity or sensor.

(3) Hydraulic oil temperature gauge

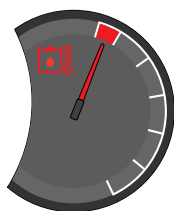

2609A3CD15

① This gauge indicates the temperature of hydraulic oil.

- White range : 40-105°C(104-221°F)
- Red range : Above 105°C(221°F)

② If the indicator is in the red range or  lamp blinks is red, reduce the load on the system. If the gauge stays in the red range, stop the machine and check the cause of the problem.

※ If the gauge indicates the red range or  lamp blinks in red even though the machine is on the normal condition, check the electric device as that can be caused by the poor connection of electricity or sensor.

(4) Fuel level gauge



2609A3CD16

① This gauge indicates the amount of fuel in the fuel tank.

② Fill the fuel when the red range, or  lamp blinks in red.

※ If the gauge indicates the red range or  lamp blinks in red even though the machine is on the normal condition, check the electric device as that can be caused by the poor connection of electricity or sensor.

(5) RPM / Tripmeter display



2609A3CD17

① This displays the engine speed or the tripmeter.

※ Refer to page 5-49 for details.

3) WARNING LAMPS





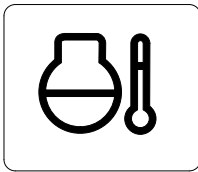

2209A3CD18

※ Each warning lamp on the top of the LCD pops up on the center of LCD and the buzzer sounds when the each warning is happened. The pop-up warning lamp moves to the original position and blinks when the select switch is pushed. And the buzzer stops. Refer to page 5-37 for the select switch.

(1) Engine coolant temperature warning lamp





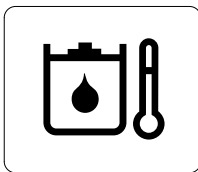

21093CD08A

- ① Engine coolant temperature warning is indicated two steps.
 - 103°C over : The  lamp blinks and the buzzer sounds.
 - 107°C over : The  lamp pops up on the center of LCD and the buzzer sounds.
- ② The pop-up  lamp moves to the original position and blinks when the select switch is pushed. Also, the buzzer stops and  lamp keeps blink.
- ③ Check the cooling system when the lamp keeps ON.

(2) Hydraulic oil temperature warning lamp



21093CD08C

- ① Hydraulic oil temperature warning is indicated two steps.
 - 100°C over : The  lamp blinks and the buzzer sounds.
 - 105°C over : The  lamp pops up on the center of LCD and the buzzer sounds.
- ② The pop-up  lamp moves to the original position and blinks when the select switch is pushed. Also, the buzzer stops and  lamp keeps blink.
- ③ Check the hydraulic oil level and hydraulic oil cooling system.

(3) Fuel level warning lamp



21093CD08B

- ① This warning lamp blinks and the buzzer sounds when the level of fuel is below 31 ℓ (8.2 U.S. gal).
- ② Fill the fuel immediately when the lamp blinks.

(4) Emergency warning lamp



21093CD30

- ① This lamp pops up and the buzzer sounds when each of the below warnings is happened.
 - Engine coolant overheating (over 107°C)
 - Hydraulic oil overheating (over 105°C)
 - Pump EPPR circuit abnormal or open
 - Attachment flow EPPR circuit abnormal or open
 - MCU input voltage abnormal
 - Accel dial circuit abnormal or open
 - Cluster communication data error
 - Engine ECM communication data error
- ※ **The pop-up warning lamp moves to the original position and blinks when the select switch is pushed. Also the buzzer stops. This is same as following warning lamps.**
- ② When this warning lamp blinks, machine must be checked and serviced immediately.

(5) Engine oil pressure warning lamp

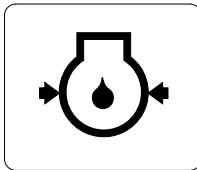

21093CD32

- ① This lamp blinks when the engine oil pressure is low.
- ② If the lamp blinks, shut OFF the engine immediately. Check oil level.

(6) Check engine warning lamp

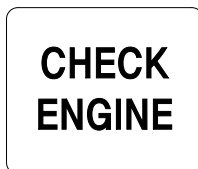

21093CD33

- ① This lamp blinks when the communication between MCU and engine ECM on the engine is abnormal, or if the cluster received any fault code from engine ECM.
- ② Check the communication line between them.
If the communication line is OK, then check the fault codes on the cluster.

(7) Battery charging warning lamp

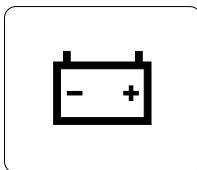

21093CD34

- ① This lamp blinks when the battery charging voltage is low.
- ② Check the battery charging circuit when this lamp blinks.

(8) Air cleaner warning lamp

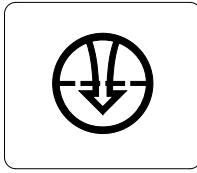

21093CD35

- ① This lamp blinks when the filter of air cleaner is clogged.
- ② Check the filter and clean or replace it.

(9) Overload warning lamp (opt)

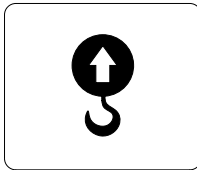

21093CD36

- ① When the machine is overload, the overload warning lamp blinks during the overload switch is ON. (if equipped)
- ② Reduce the machine load.

4) PILOT LAMPS



2609A3CD22

(1) Mode pilot lamps

No	Mode	Pilot lamp	Selected mode
1	Power mode		Heavy duty power work mode
			Standard power mode
			Economy power mode
2	User mode		User preferable power mode
3	Work mode		General operation mode
			Breaker operation mode
			Crusher operation mode
4	Travel mode		Low speed traveling
			High speed traveling
5	Auto idle mode		Auto idle
6	Work tool mode		Oil flow level of breaker or crusher mode

(2) Power max pilot lamp



21093CD38

- ① The lamp will be ON when pushing power max switch on the LH RCV lever.
 - ② The power max function is operated maximum 8 seconds.
- ※ Refer to the operator's manual page 3-28 for power max function.

(3) Preheat pilot lamp

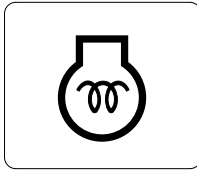

21093CD39

- ① Turning the start key switch ON position starts preheating in cold weather.
- ② Start the engine after this lamp is OFF.

(4) Warming up pilot lamp

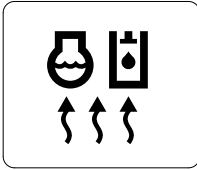

21093CD40

- ① This lamp is turned ON after 1 minute from engine start when the coolant temperature is below 30°C (86°F).
- ② The automatic warming up is cancelled when the engine coolant temperature is above 30°C, or when 10 minutes have passed since starting the engine.

(5) Decel pilot lamp

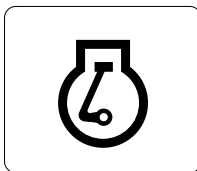

21093CD41

- ① Operating one touch decel switch on the RCV lever makes the lamp ON.
 - ② Also, the lamp will be ON and engine speed will be lowered automatically to save fuel consumption when all levers and pedals are at neutral position, and the auto idle function is selected.
- ※ **One touch decel is not available when the auto idle pilot lamp is turned ON.**
- ※ **Refer to the operator's manual page 3-28.**

(6) Fuel warmer pilot lamp

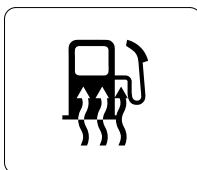

21093CD43

- ① This lamp is turned ON when the coolant temperature is below 10°C (50°F) or the hydraulic oil temperature 20°C (68°F).
- ② The automatic fuel warming is cancelled when the engine coolant temperature is above 60°C, or the hydraulic oil temperature is above 45°C since the start switch was ON position.

(7) Maintenance pilot lamp

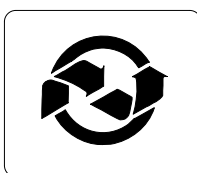

2609A3CD23

- ① This lamp will be ON when the consuming parts are needed to change or replace. It means that the change or replacement interval of the consuming parts remains below 30 hours.
 - ② Check the message in maintenance information of main menu. Also, this lamp lights ON for 3 minutes when the start switch is ON position.
- ※ **Refer to the page 5-42.**

(8) Entertainment pilot lamp

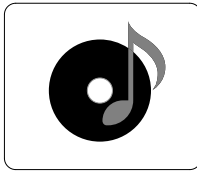

2609A3CD133

- ① This lamp is on when MP3 or video files are playing.
- ※ **Refer to the page 5-48.**

(9) Smart key pilot lamp (opt)

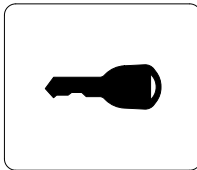

2609A3CD132

- ① This lamp is ON when the engine is started by the start button.
- ② This lamp is red when the a authentication fails, green when succeeds.
- ※ **Refer to the page 5-44.**

5) SWITCHES

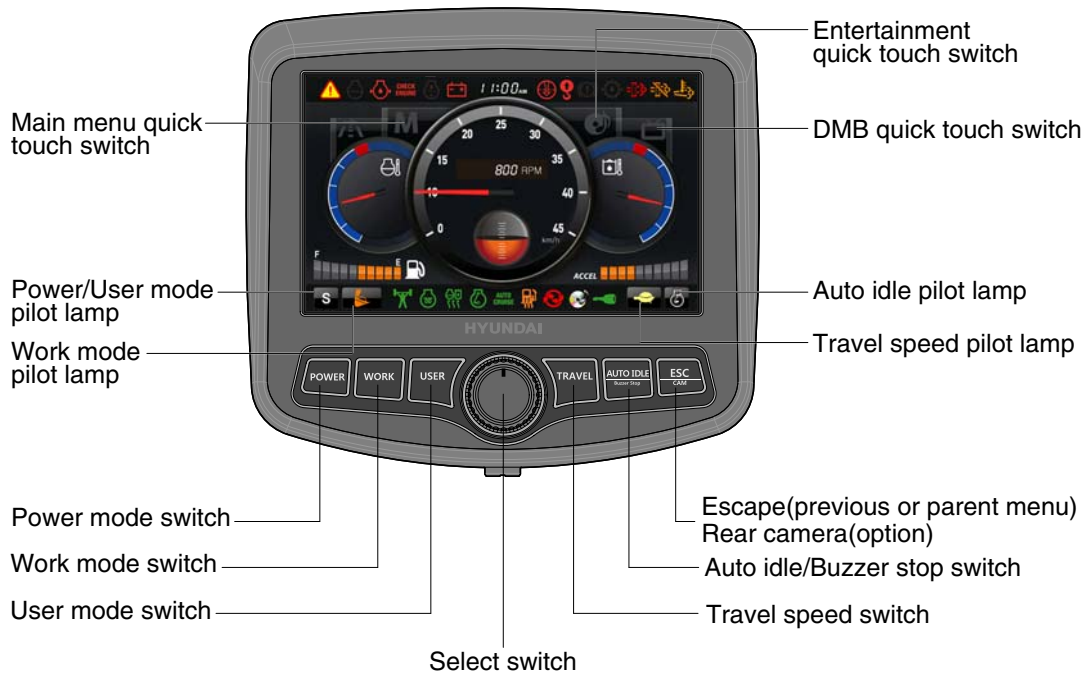

2609A3CD24

※ When the switches are selected, the pilot lamps are displayed on the LCD. Refer to the page 5-52 for details.

(1) Power mode switch

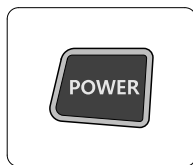



2609A3CD25

- This switch is to select the machine power mode and selected power mode pilot lamp is displayed on the pilot lamp position.
 - P : Heavy duty power work.
 - S : Standard power work.
 - E : Economy power work.
- The pilot lamp changes E → S → P → E in order.

(2) Work mode switch



2609A3CD26

- This switch is to select the machine work mode, which shifts from general operation mode to optional attachment operation mode.
 -  : General operation mode
 -  : Breaker operation mode (if equipped)
 -  : Crusher operation mode (if equipped)
 - Not installed : Breaker or crusher is not installed.

※ Refer to the operator's manual page 4-7 for details.

(3) User mode switch

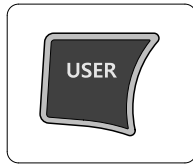

2609A3CD27

- ① This switch is used to memorize the current machine operating status in the MCU and activate the memorized user mode.
 - Memory : Push more than 2 seconds.
 - Action : Push within 2 seconds.
 - Cancel : Push this switch once more within 2 seconds.

(4) Select switch

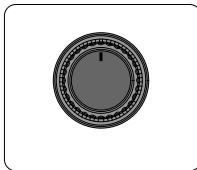

21093CD45E

- ① This switch is used to select or change the menu and input value.
- ② Knob push
 - Long (over 2 sec) : Return to the operation screen
 - Medium (0.5~2 sec) : Return to the previous screen
 - Short (below 0.5 sec) : Select menu
- ③ Knob rotation
This knob changes menu and input value.
 - Right turning : Down direction / Increase input value
 - Left turning : Up direction / Decreased input value

(5) Auto idle/ buzzer stop switch

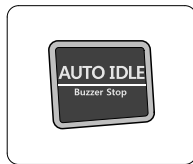



2609A3CD28

- ① This switch is used to activate or cancel the auto idle function.
 - Pilot lamp ON : Auto idle function is activated.
 - Pilot lamp OFF : Auto idle function is cancelled.
- ② The buzzer sounds when the machine has a problem.
In this case, push this switch and buzzer stops, but the warning lamp blinks until the problem is cleared.

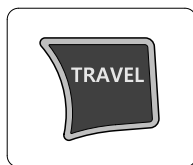
(6) Travel speed control switch



2609A3CD29

- ① This switch is used to select the travel speed alternatively.
 -  : Low speed
 -  : High speed

(7) Escape/Camera switch

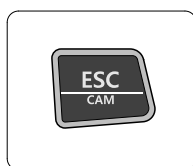

2609A3CD30

- ① This switch is used to return to the previous menu or parent menu.
- ② In the operation screen, pushing this switch will display the view of the camera on the machine (if equipped).
Please refer to page 5-49 for the camera.
- ③ If the camera is not installed, this switch is used only ESC function.

6) MAIN MENU

※ You can select or set the menu by the select switch or touch screen (M).

On the operation screen, tap M to access the main menu screen.

On the sub menu screen, you can tap the menu bar to access functions or applications





To return to the parent menu screen, tap the top menu bar. To return to operation screen, tap (🏠) icon.

· Operation screen



※ Please refer to select switch, page 5-56 for selection and change of menu and input value.

(1) Structure

No	Main menu	Sub menu	Description
1	 Mode 2609A3CD33	Work tool U mode power Boom/Arm speed Auto power boost Initial mode	Breaker, Crusher, Not installed User mode only Boom speed, Arm speed Enable, Disable Default, U mode, P mode
2	 Monitoring 2609A3CD34	Active fault Logged fault Delete logged fault Monitoring (analog) Monitoring (digital) Operating hours	MCU, Engine ECM MCU, Engine ECM All logged fault delete, Initialization canceled Machine information Switch status, Output status Operating hours for each mode
3	 Management 2609A3CD35	Maintenance information Machine security Machine Information A/S phone number Service menu Clinometer	Replacement, Change interval oils and filters ESL mode setting, Password change Cluster, MCU, Engine, Machine A/S phone number, A/S phone number change grade Power shift, Hourmeter, Replacement history, Lock lever, Upgrade, EPPR current level Clinometer setting
4	 Display 2609A3CD36	Display item Clock Brightness, Touch calibration Unit setup Language selection Screen type	Engine speed, Tripmeter A, Tripmeter B, Tripmeter C Clock Manual, Auto, Calibrating the touch screen Temperature, Pressure, Flow, Distance, Date format Korean, English, Chinese A type, B type
5	 Utilities 2609A3CD37	Entertainment Tripmeter Camera FMT DMB	Play MP4, codec. 3 kinds (A, B, C) Number of active, Display order, Camera No. FMT setting DMB select, DAB select, Channel scan, Exit

④ Auto power boost



2609A3CD45

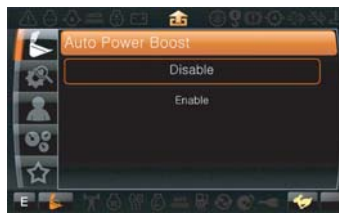

2609A3CD46

- The power boost function can be activated or cancelled.
- Enable - The digging power is automatically increased as working conditions by the MCU. It is operated max 8 seconds.
- Disable - Not operated.

⑤ Initial mode



2609A3CD47



2609A3CD48

- Default - The initial power mode is set E mode when the engine is started.
- U mode - The initial power mode is set U mode when the engine is started.

(3) Monitoring

① Active fault



2609A3CD51



2609A3CD52



2609A3CD53

- The active faults of the MCU or engine ECM can be checked by this menu.

② Logged fault



2609A3CD54



2609A3CD55



2609A3CD56

- The logged faults of the MCU or engine ECM can be checked by this menu.

③ Delete logged fault



- The logged faults of the MCU or engine ECM can be deleted by this menu.

④ Monitoring(analog)



- The machine status such as the engine rpm, oil temperature, voltage and pressure etc. can be checked by this menu.

⑤ Monitoring (digital)



- The switch status or output status can be confirmed by this menu.
- The activated switch or output pilot lamps  are light ON.

⑥ Operating hours



- The operating hour of each mode can be confirmed by this menu.

② Machine security



· ESL mode setting

- ESL : Engine Starting Limit
- ESL mode is designed to be a theft deterrent or will prevent the unauthorized operation of the machine.
- If the ESL mode was selected Enable, the password will be required when the start switch is turned ON.

- Machine security

Disable : Not used ESL function

Enable (always) : The password is required whenever the operator starts engine.



- **Interval** : The password is required when the operator starts engine first. But the operator can restart the engine within the interval time without inputting the password.

The interval time can be set maximum 4 hours.

※ Default password : 00000 *

※ Password length : (5~10 digit) + *



- **Smart key (option)** : Smart key is registered when the operator starts engine by start button first. If smart key is not inside of the cabin, authentication process fails and the password entering is needed.

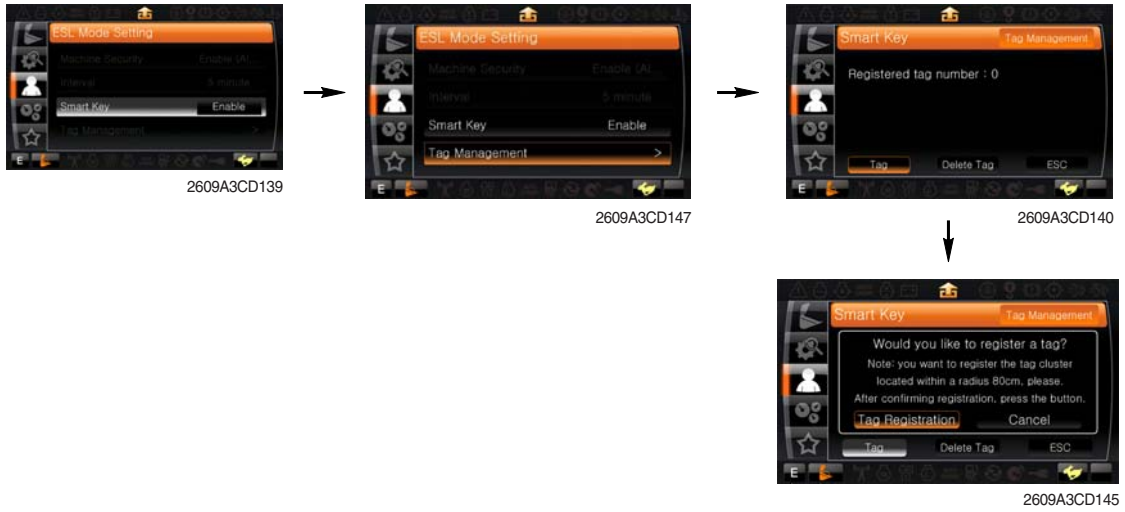

· **Password change**

- The password is 5~10 digits.

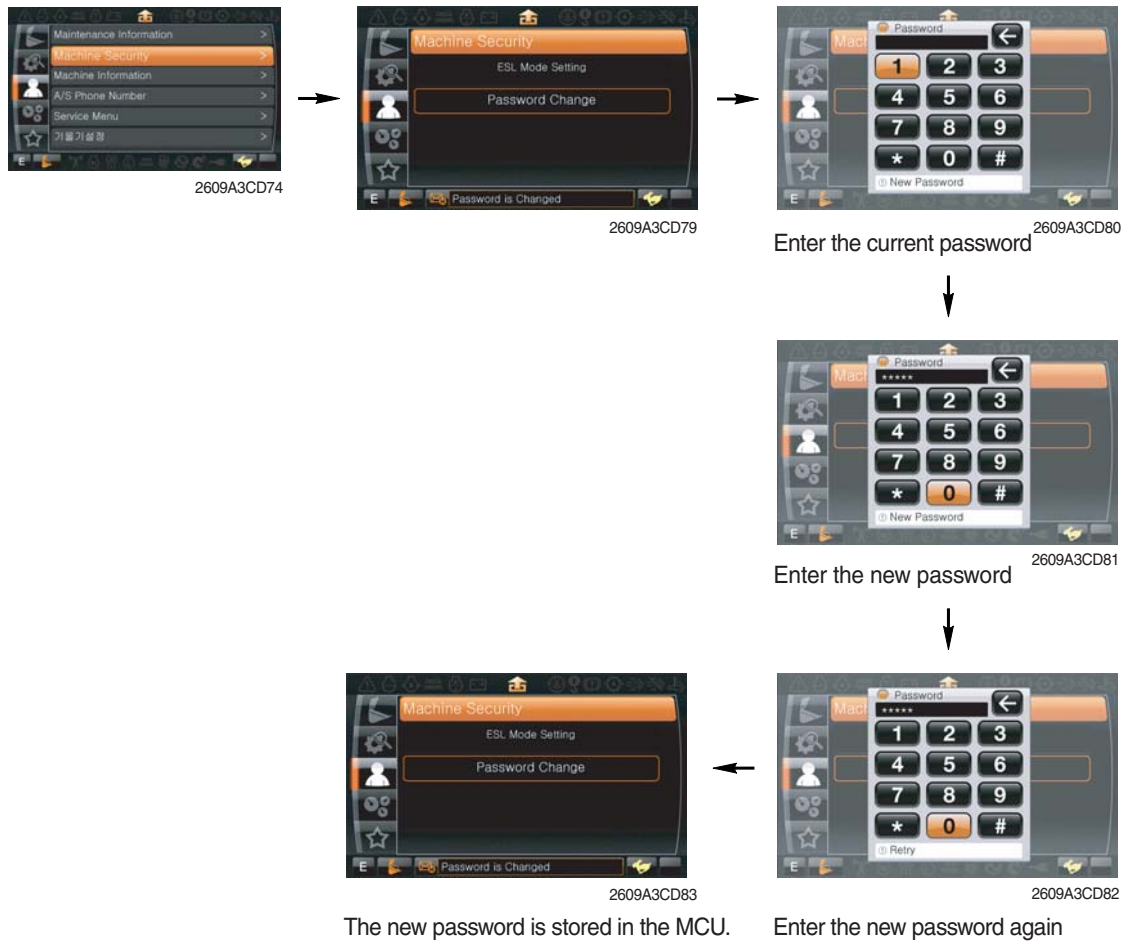

③ Machine Information



- This can confirm the identification of the cluster, MCU, engine and machine.

④ A/S phone number

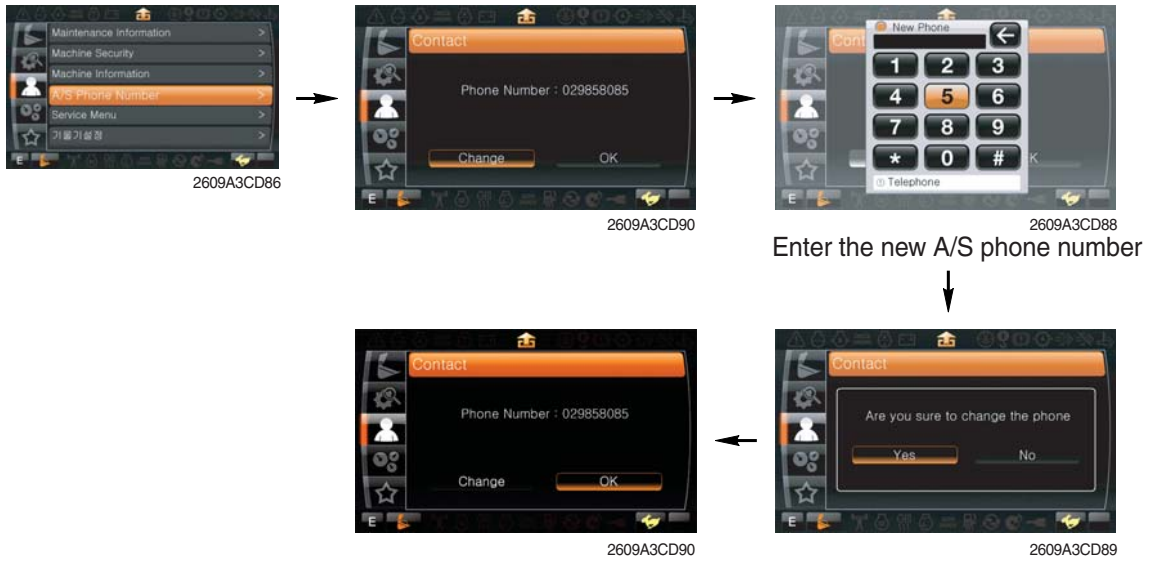

Enter the new A/S phone number

The new phone number is stored in MCU

⑤ Service menu

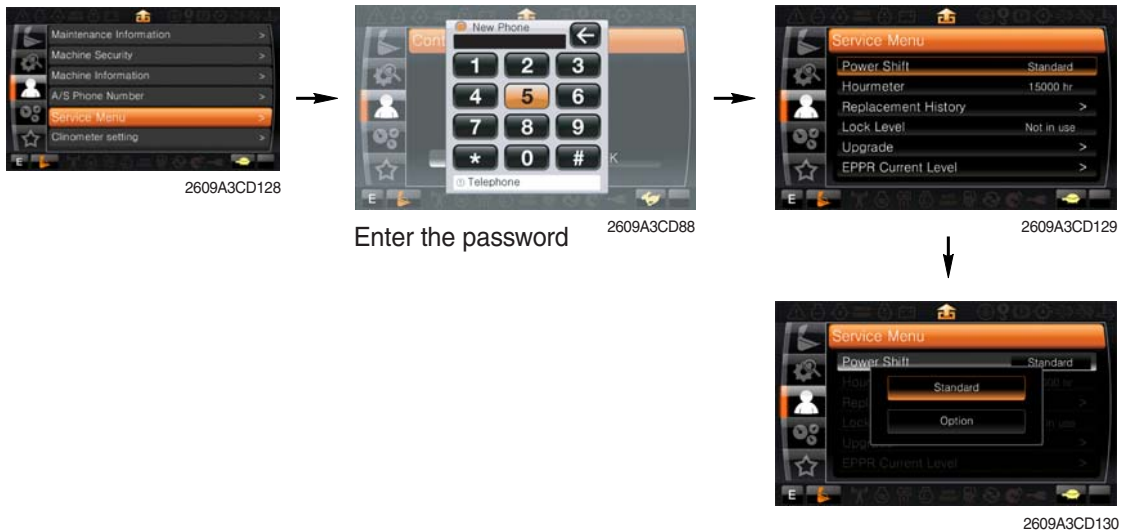

- Power shift (standard/option) : Power shift pressure can be set by option menu.
- Hourmeter : Operating hours since the machine line out can be checked by this menu.
- Replacement history : Replacement history of the MCU and cluster can be checked by this menu.
- Lock level (not in use/in use)
- Upgrade : Firm ware can be upgraded by this menu. (the USB port is located under the cluster)
- EPPR current level (attach EPPR/boom priority EPPR)

⑥ Clinometer

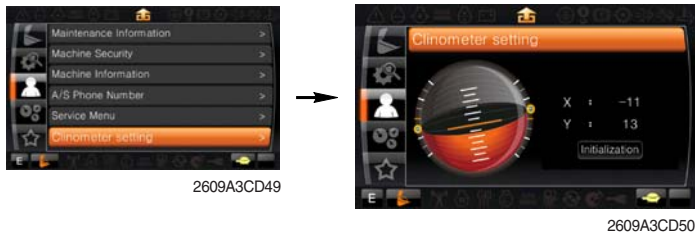

- When the machine is on the flatland, if tap the "initialization", the values of X, Y reset "0".
- You can confirm tilt of machine in cluster's operating screen.

(5) Display

① Display item



- The center display type of the LCD can be selected by this menu.
- The engine speed or each of the tripmeter (A,B,C) is displayed on the center display.

② Clock



- The first line's three spots "**/**/****" represent Month/Day/Year each.
- The second line shows the current time. (0:00~23:59)

③ Brightness and touch calibration

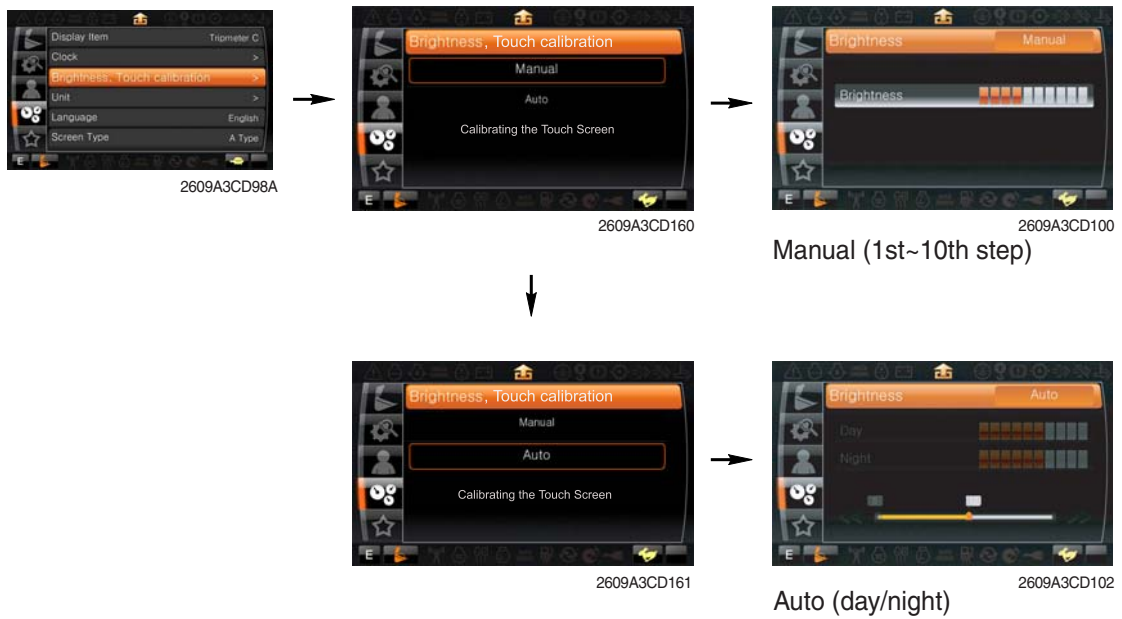

- If "Auto" is chosen, brightness for day and night can be differently set up. Also by using the bar in lower side, users can define which time interval belongs to day and night. (in bar figure, white area represents night time while orange shows day time)
- **Touch calibration** - When touch awareness goes wrong, this function use.
 Fall in the next step if touches the middle point of cross with fingernail.
 If touches total five points as follows, the setting is completed.

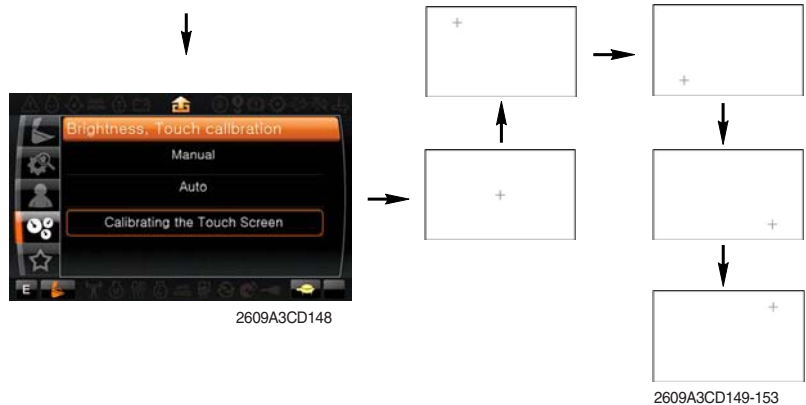

④ Unit



- Temperature : °C ↔ °F
- Pressure : bar ↔ MPa ↔ kgf/cm²
- Flow : lpm ↔ gpm
- Distance : km ↔ mile
- Date format : yy/mm/dd ↔ mm/dd/yy ↔ dd-Mar-yy

⑤ Language



- User can select preferable language and all displays are changed the selected language.

⑥ Screen type

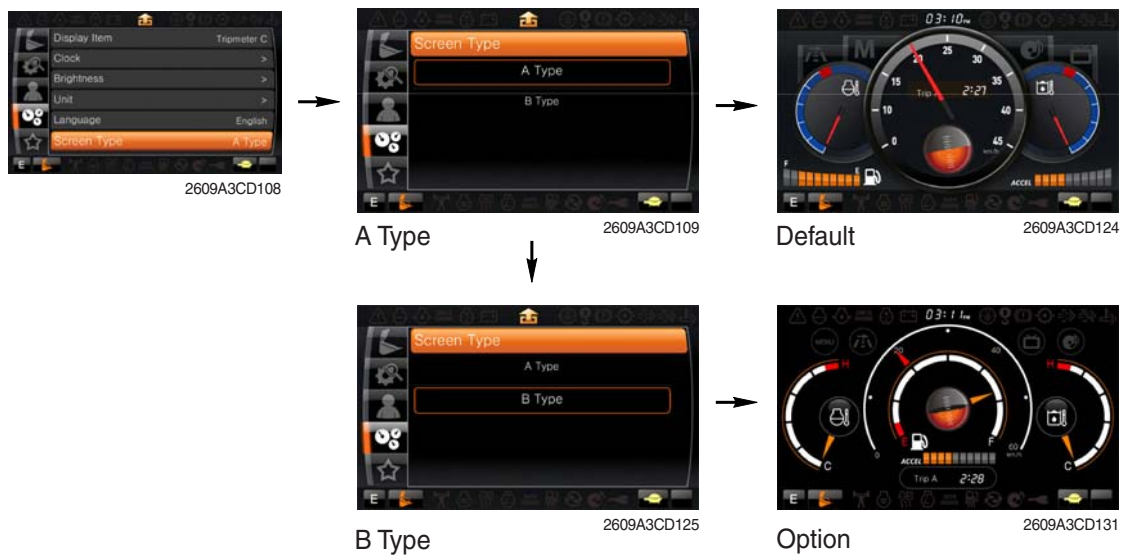

(6) Utilities

① Entertainment

- Play MP4 or codec file of external hard disk through USB port.
- The USB port is located under the cluster.



- Over 1100 engine rpm, the screen turns into the operation screen with MP4 or codec file playing for the safety.

② Tripmeter



- Maximum 3 kinds of tripmeters can be used at the same time.
- Each tripmeter can be turned on by choosing "Start" while it also can be turned off by choosing "Stop".
- If the tripmeter icon is activated in the operation screen, it can be controlled directly there.

③ Camera setting

- Three cameras can be installed on the machine and the display order can be set by this menu.
- If the camera was not equipped, this menu is not useful.



- Turning the select switch in clockwise direction, the next ordered will be shown and in counter-clockwise direction, the previously ordered will be shown.
- Push the select switch, the displayed screen will be enlargement.



④ FMT setting



2609A3CD121



2609A3CD154



2609A3CD155



2609A3CD156



2609A3CD157



2609A3CD158



2609A3CD159

- The function that can listen cluster's occurrence sound by inside speaker of cabin making frequency of audio identical in cluster's frequency and machine.
- Turn on the FMT function and sets frequency equally with frequency of audio in cabin.
 - Not in use : Cluster speaker only
 - In use (FMT only) : Cabin speaker only
 - In use (FMT+Built) : Cabin speaker + Cluster speaker

⑤ DMB (option)



2609A3CD112



2609A3CD113

GROUP 15 FUEL WARMER SYSTEM

1. SPECIFICATION

- 1) Operating voltage : 24 ± 4 V
- 2) Power : 350 ± 50 W
- 3) Current : 15 A

2. OPERATION

- 1) The current of fuel warmer system is automatically controlled without thermostat according to fuel temperature.
- 2) At the first state, the 15 A current flows to the fuel warmer and engine may be started in 1~2 minutes.
- 3) If the fuel starts to flow, ceramic-disk in the fuel warmer heater senses the fuel temperature to reduce the current as low as 1.5 A.
So, fuel is protected from overheating by this mechanism.

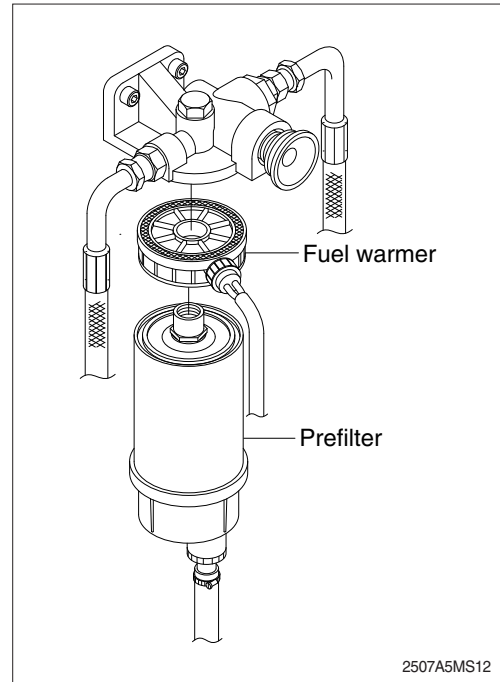

2507A5MS12

3. ELECTRIC CIRCUIT

