

SECTION 5 MECHATRONICS SYSTEM

Group 1 Outline	5-1
Group 2 Mode Selection System	5-3
Group 3 Automatic Deceleration System	5-5
Group 4 Power Boost System	5-6
Group 5 Travel Speed Control System	5-7
Group 6 Automatic Warming Up Function	5-8
Group 7 Engine Overheat Prevention Function	5-9
Group 8 Anti-Restart System	5-10
Group 9 Self-Diagnostic System	5-11
Group 10 Engine Control System	5-14
Group 11 EPPR(Electro Proportional Pressure Reducing) Valve	5-20
Group 12 Monitoring System	5-23

SECTION 5 MECHATRONICS SYSTEM

GROUP 1 OUTLINE

The NEW CAPO(Computer Aided Power Optimization) system controls engine and pump mutual power at an optimum and less fuel consuming state for the selected work by mode selection, auto-deceleration, power boost function, etc. It monitors machine conditions, for instance, engine speed, coolant temperature, hydraulic oil temperature, and hydraulic oil pressure, etc.

It consists of a MCU, a cluster, an accel actuator, an EPPR valve, and other components. The MCU and the cluster protect themselves from over-current and high voltage input, and diagnose malfunctions caused by short or open circuit in electric system, and display error codes on the cluster.

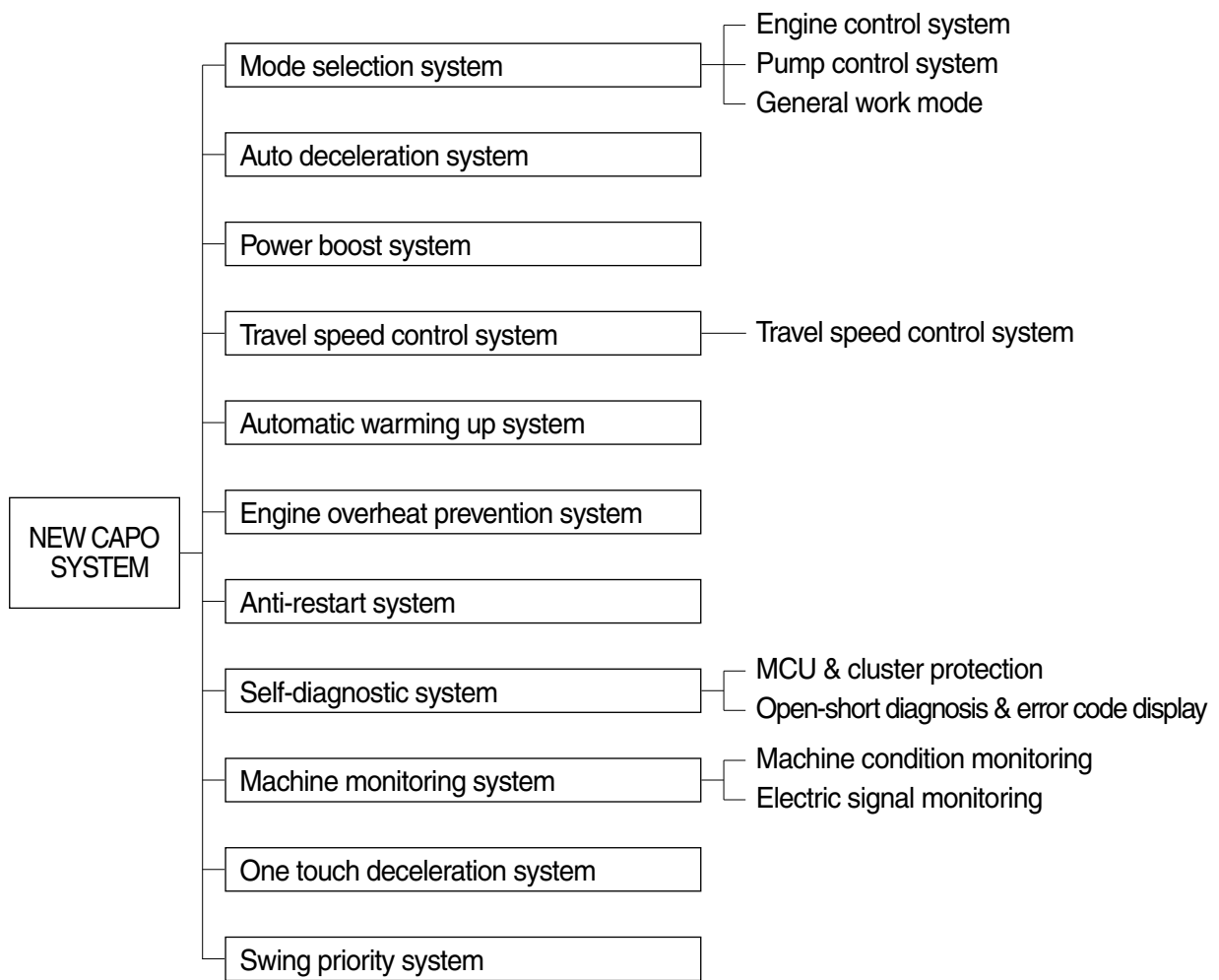

SYSTEM DIAGRAM

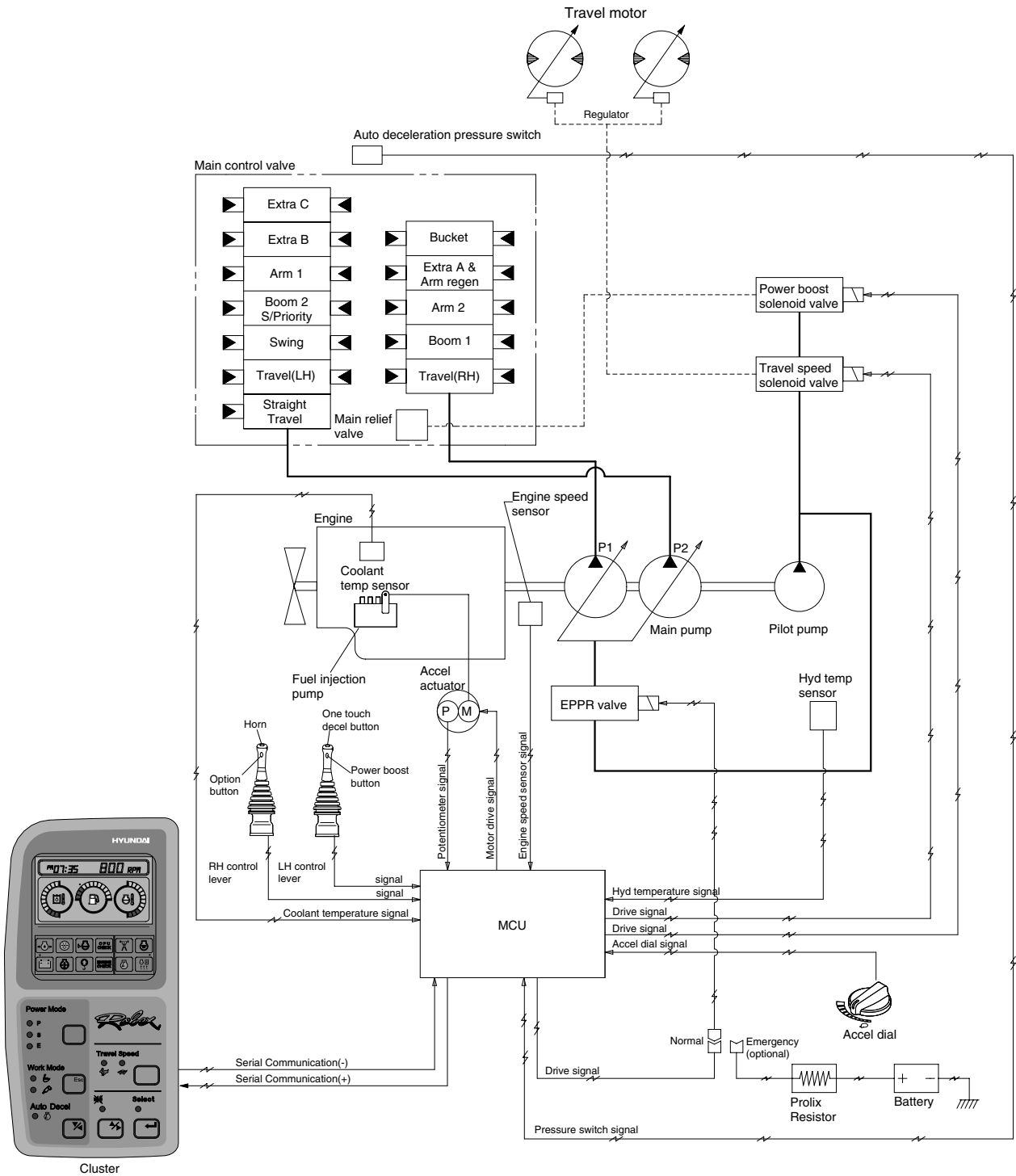

140V95MS01

GROUP 2 MODE SELECTION SYSTEM

1. POWER MODE SELECTION SYSTEM

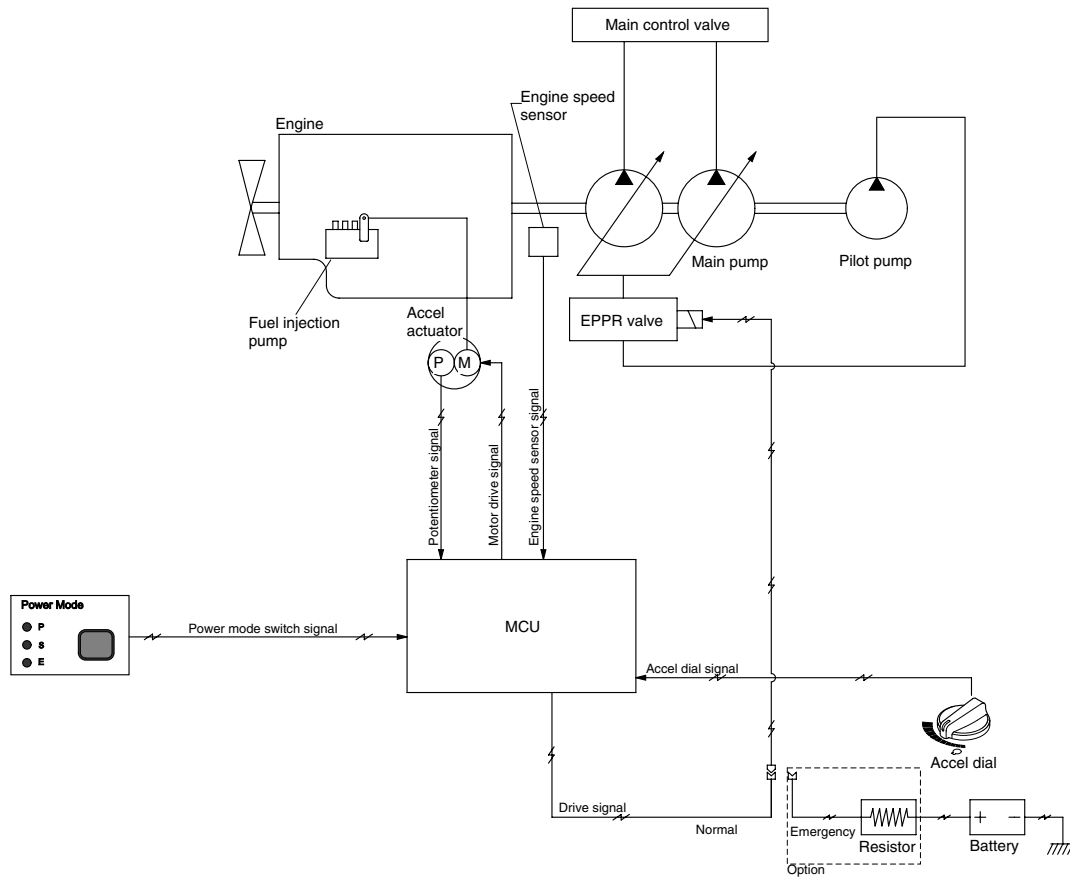

140V95MS07

Mode selection system(Micro computer based electro-hydraulic pump and engine mutual control system) optimizes the engine and pump performance.

The combination of 3 power modes(P, S, E) and accel dial position(10 set) makes it possible to use the engine and pump power more effectively corresponding to the work conditions from a heavy and great power requesting work to a light and precise work.

Mode	Application	Engine rpm				Power shift by EPPR valve			
		Default		Other case		Default		Other case	
		Unload	Load	Unload	Load	Current (mA)	Pressure (kgf/cm ²)	Current (mA)	Pressure (kgf/cm ²)
P	Maximum power	2100	1900	2150	1950	290±30	8	250	5
S	High power	1950±50	1750	2000	1800	360±30	12	280	7
E	Standard power	1800±50	1600	1850	1650	400±30	15	330	10
AUTO DECEL	Engine deceleration	1200±100	-	1200±100	-	700±30	38	700±30	38
One touch decel	Engine quick deceleration	950±100	-	950±100	-	700±30	38	700±30	38
KEY START	Key switch start position	950±100	-	950±100	-	700±30	38	700±30	38

※ Other case can be set by pressing the "travel speed" switch and "buzzer stop switch" for 2 seconds at the same time in "model & version" display on the cluster(for detail, see 5-21)

2. GENERAL WORK MODE

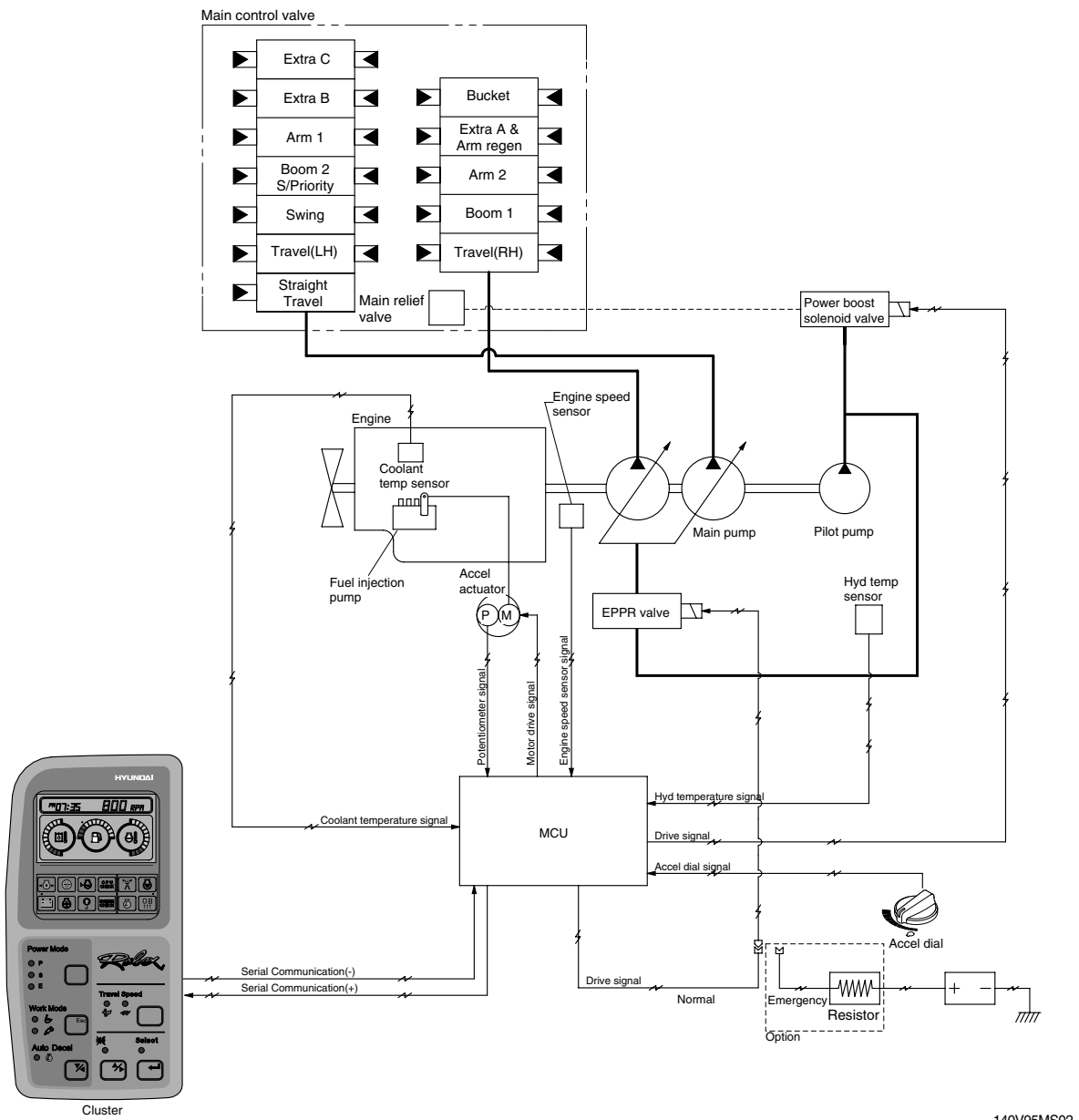

140V95MS02

GROUP 3 AUTOMATIC DECELERATION SYSTEM

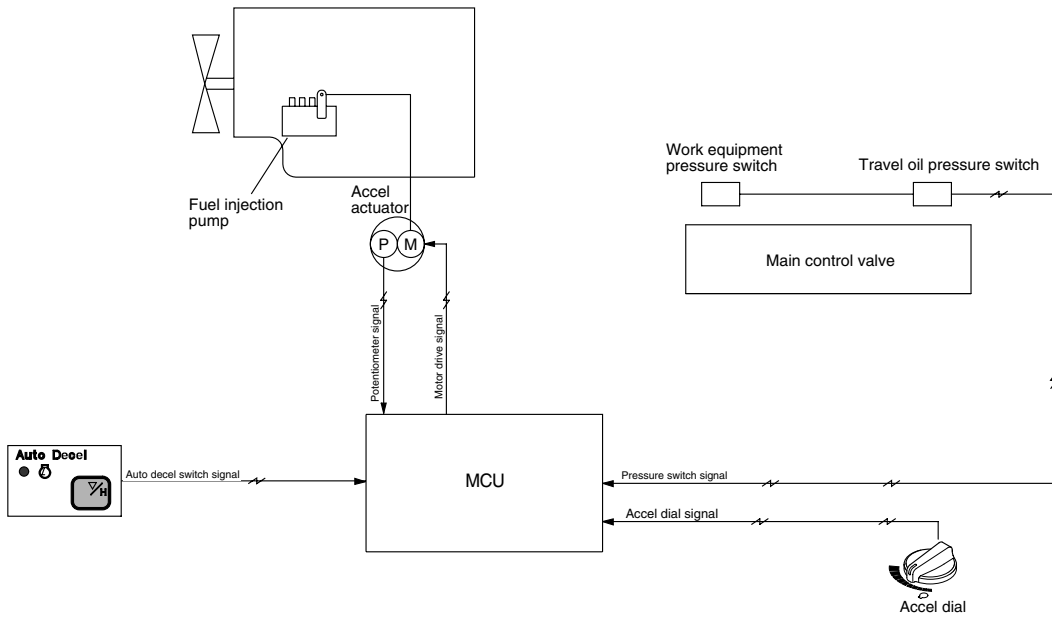

1. WHEN AUTO DECEL LAMP ON

If all the work equipment control levers including swing and travel levers are at neutral for at least 4 seconds, MCU drives the governor motor to reduce the engine speed to 1200rpm. As the result of reducing the engine speed, fuel consumption and noise are effectively cut down during non-operation of the control levers.

When the Auto decel lamp is turned off by pressing the switch or any control lever is operated, the reduced engine speed rises up to the speed set before deceleration in a second.

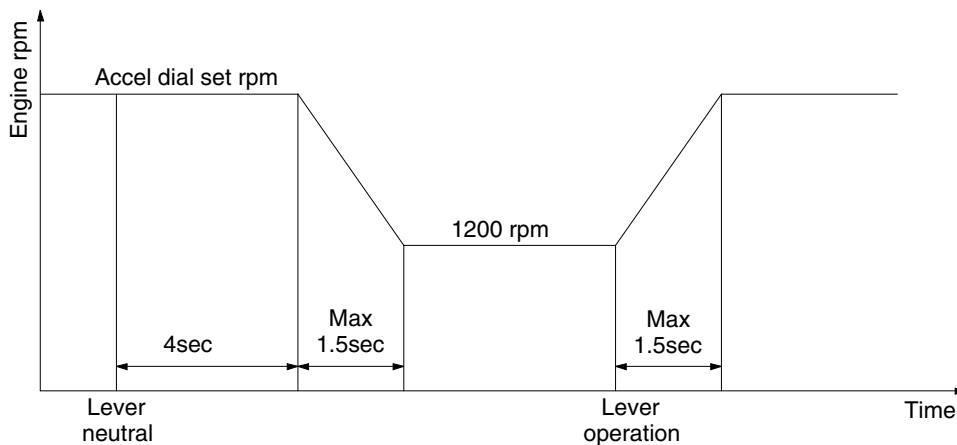

2. WHEN AUTO DECEL LAMP OFF

The engine speed can be set as desired using the engine speed switch, and even if the control levers are neutral, the engine speed is not reduced.

Note : Auto decel function can be activated when accel dial position is over 4.

GROUP 4 POWER BOOST SYSTEM

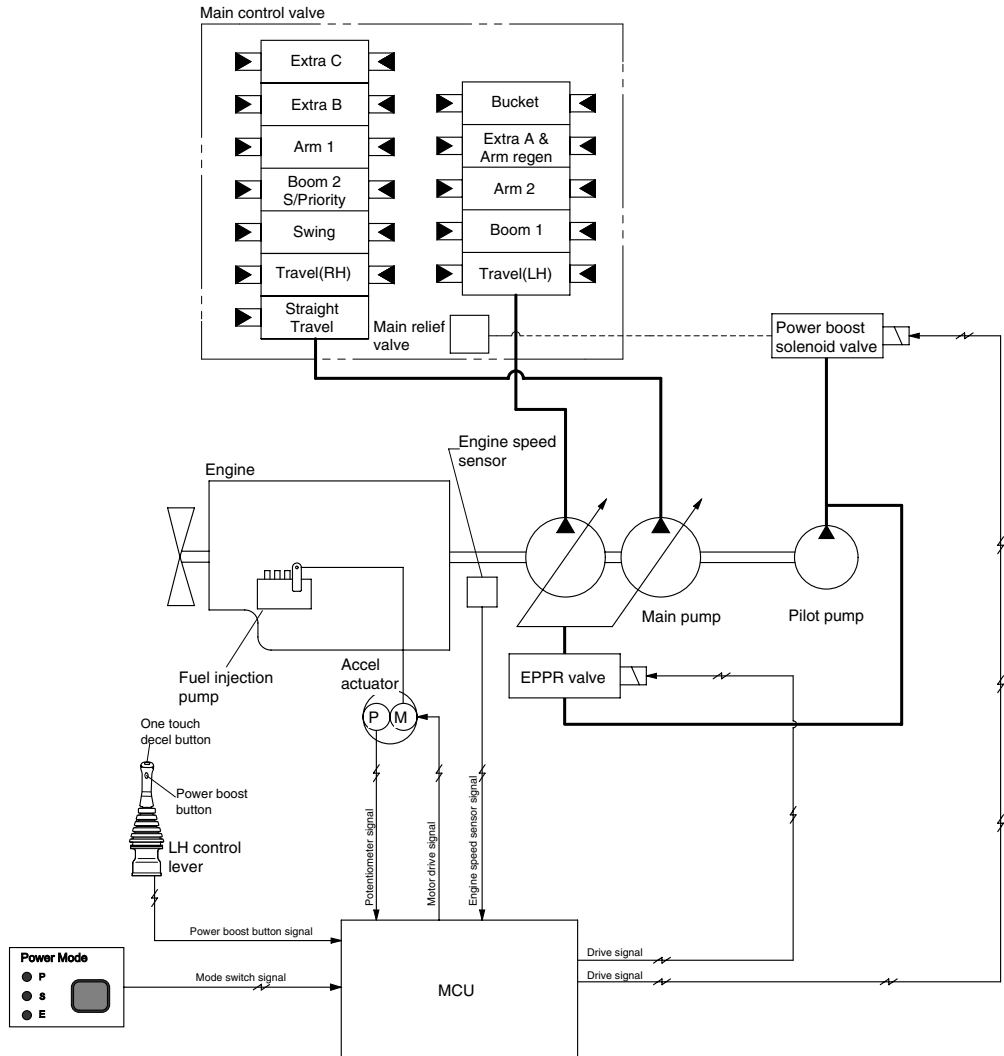

140V95MS03

- When the power boost switch on the left control lever knob is pushed ON, the maximum digging power is increased by 10%.
- When the power set is at H or S and the power boost function is activated, the power boost solenoid valve pilot pressure raises the set pressure of the main relief valve to increase the digging power.

Description	Power boost switch	
	OFF	ON
Power set	P, S or E	P or S
Main relief valve set pressure	330kgf/cm ²	360kgf/cm ²
Time of operation	-	Even when pressed continuously, it is canceled after 8 sec.

※ Default - Power boost solenoid valve : OFF

GROUP 5 TRAVEL SPEED CONTROL SYSTEM

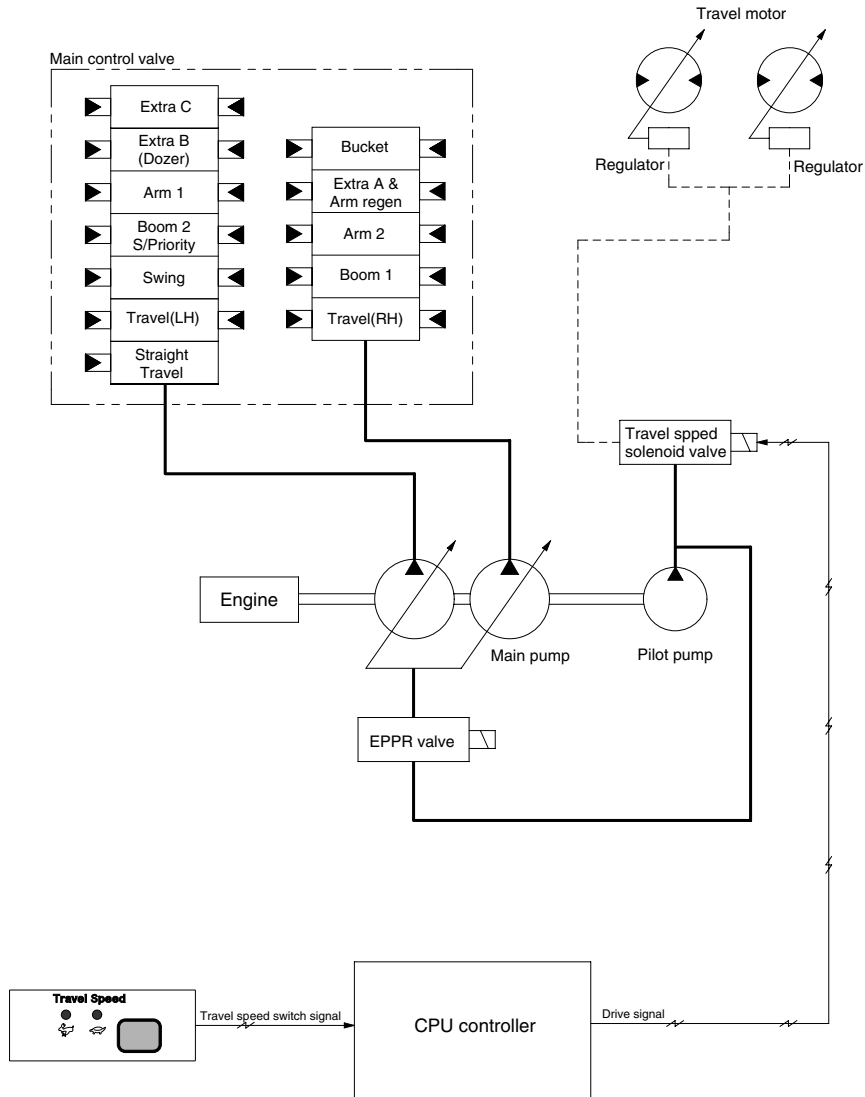

140V95MS08

Travel speed can be switched manually by pressing the travel speed switch on the cluster.

Speed	Travel speed solenoid valve	Lamp on cluster	Operation
Lo	OFF	Turtle	Low speed, high driving torque in the travel motor
Hi	ON	Rabbit	High speed, low driving torque in the travel motor

※ Default : Turtle(Lo)

GROUP 6 AUTOMATIC WARMING UP FUNCTION

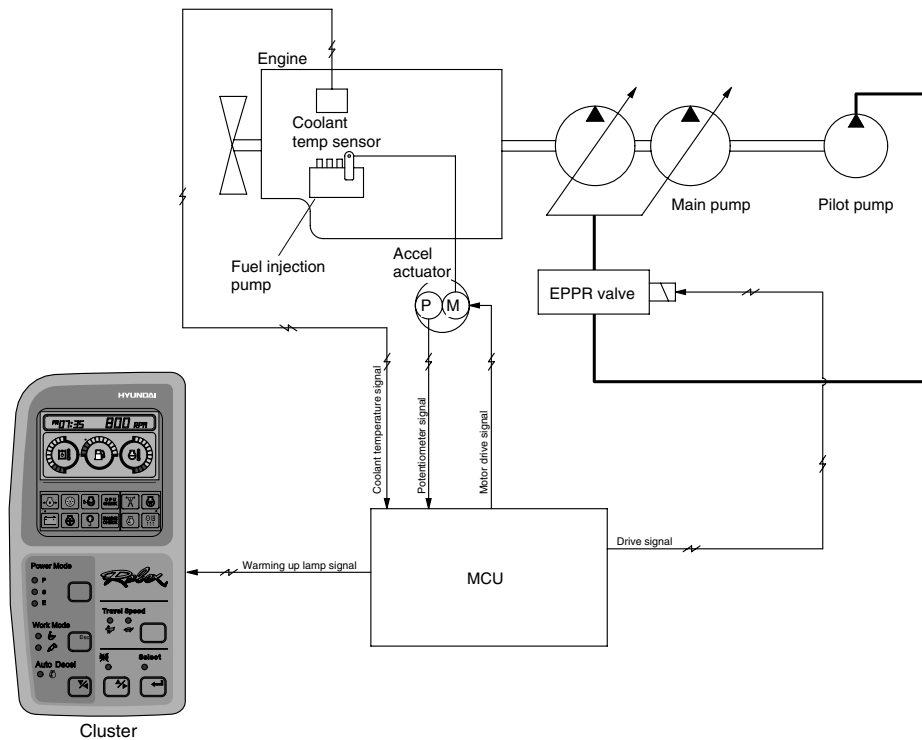

140V95MS04

1. The MCU reads engine coolant temperature through the temperature sensor, and if the coolant temperature is less than 30°C, it increases the engine speed from key start rpm to 1200rpm. At this time the mode does not change.
2. In case of the coolant temperature increases up to 30°C, the engine speed is decreased to key start speed. And if an operator changes mode set during the warming up function, the MCU cancels the automatic warming up function.

3. LOGIC TABLE

Description	Condition	Function
Actuated	- Coolant temperature : Less than 30°C(After engine run) - Accel dial position is under 3	- Mode : Default(S mode) - Warming up time : 10 minutes(Max) - Warming up lamp : ON
Canceled	- Coolant temperature : Above 30°C - Warming up time : Above 10 minutes - Changed mode set by operator - Increase engine speed by rotating accel dial clockwise ※ If any of the above conditions is applicable, the automatic warming up function is canceled	- Default mode - Default mode - Changed mode
Warming up lamp	- Coolant temperature : Above 30°C	- Warming up lamp : OFF

GROUP 7 ENGINE OVERHEAT PREVENTION FUNCTION

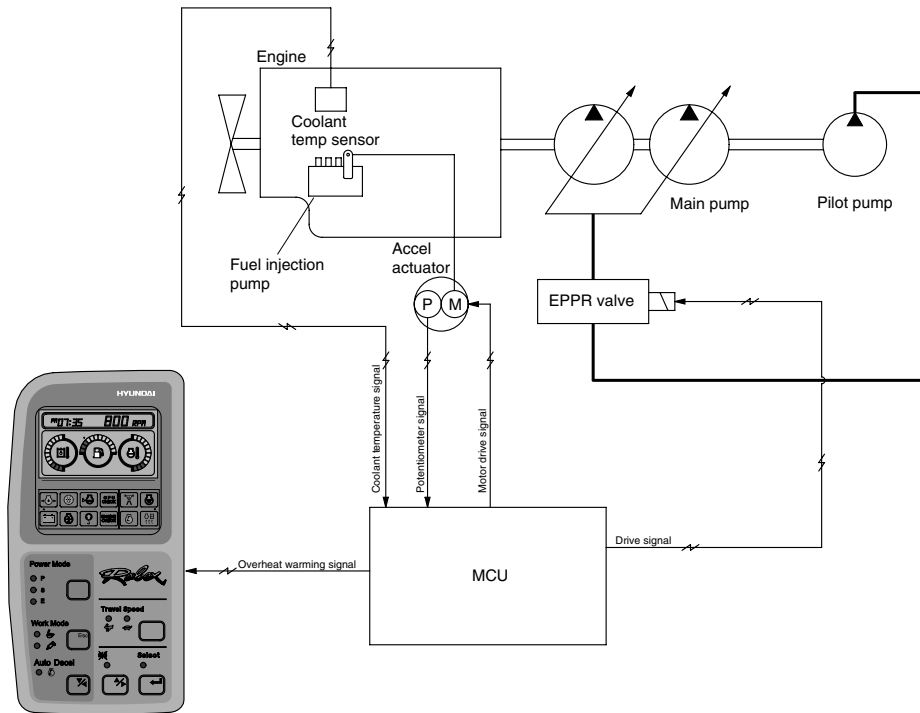

140V95MS05

1. MCU reads engine coolant temperature through the temperature sensor and when the engine coolant boils up to 110°C, it sends overheat warning signal to the cluster and decrease the engine speed same as accel dial 7 position.
2. If the coolant temperature drops less than 100°C, the MCU returns the mode to the mode set before. And if mode set is changed during the function, the MCU cancels the function. Even if the overheat prevention function is canceled by mode change, the overheat warning lamp turns OFF only when the coolant temperature is less than 100°C.

3. LOGIC TABLE

Description	Condition	Function
Actuated	- Coolant temperature : Above 110°C - Accel dial set : Above 8	- Engine rpm drop to accel dial 7 position - Overheat warning lamp & buzzer : ON
Canceled	- Coolant temperature : Less than 100°C - Changed mode set by operator ※ If any of the above conditions is applicable, engine overheat prevention function is canceled	- Return to the mode and accel dial set before - Hold on the changed set
Overheat warning lamp	- Coolant temperature : Less than 100°C	- Overheat warning lamp : OFF

GROUP 8 ANTI-RESTART SYSTEM

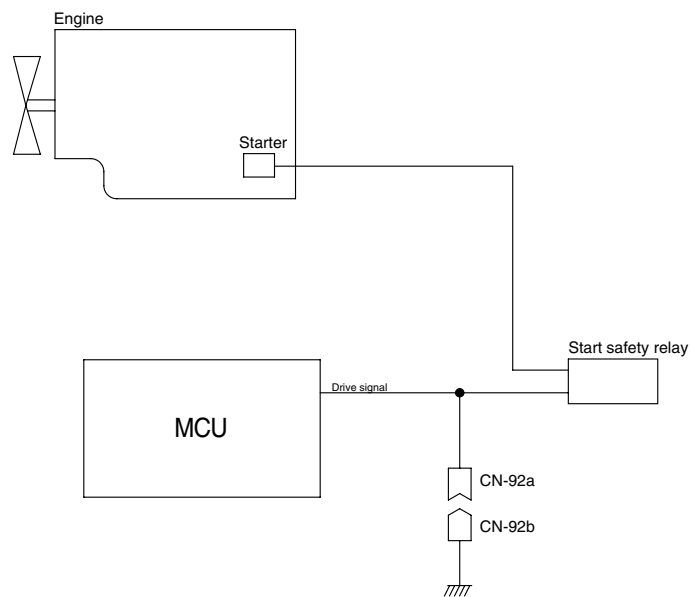

1. ANTI-RESTART FUNCTION

After 10 seconds from the engine starts to run, MCU turns off the start safety relay to protect the starter from inadvertent restarting.

2. When a replacement or taking-off of the MCU is needed, connect CN-92a and CN-92b to ensure the engine start without the MCU.

GROUP 9 SELF-DIAGNOSTIC SYSTEM

1. OUTLINE

When any abnormality occurs in the NEW CAPO system caused by electric parts malfunction and by open or short circuit, the MCU diagnoses the problem and sends the error codes to the cluster and also stores them in the memory.

2. CURRENT ERROR DISPLAY

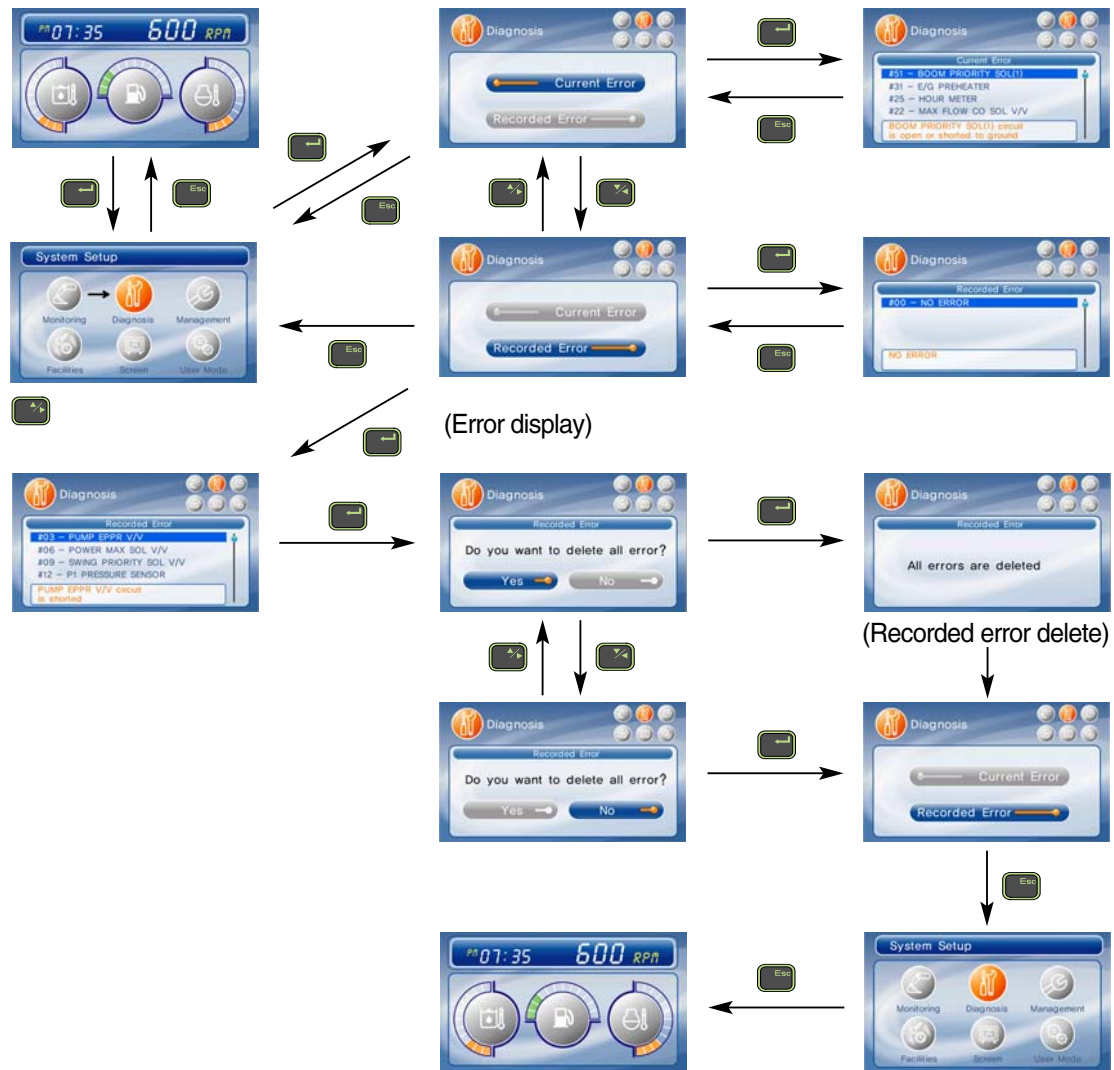

5. ERROR CODES TABLE

Fault code No.	Description
1	Short circuit in governor motor system
2	Potentiometer circuit is shorted to Vcc(5V) or battery +
3	Short circuit in pump EPPR valve system
4	Short circuit in boom down EPPR valve system
5	Short circuit in travel speed solenoid system
6	Short circuit in power boost solenoid system
7	Short circuit in max flow solenoid system
10	Short circuit in hour-meter system
11	Accel dial circuit is shorted to Vcc(5V) or battery +
12	P1 pressure sensor circuit is shorted to power supply(24V) line
13	P2 pressure sensor circuit is shorted to power supply(24V) line
14	P3 pressure sensor circuit is shorted to power supply(24) line
15	Boom down pressure circuit is shorted to power supply(24V) line
16	Governor motor circuit is open or shorted to ground
17	Potentiometer circuit is open or shorted to ground
18	Pump EPPR valve circuit is open or shorted to ground
19	Boom down EPPR valve circuit is open or shorted to ground
20	Travel speed solenoid circuit is open or shorted to ground
21	Power boost solenoid circuit is open or shorted to ground
22	Max flow solenoid circuit is open or shorted to ground
25	Hour-meter circuit is open or shorted to ground
26	Accel dial circuit is open or shorted to ground
27	P1 pressure sensor circuit is open or shorted to ground
28	P2 pressure sensor circuit is open or shorted to ground
29	P3 pressure sensor circuit is open or shorted to ground
30	Boom down pressure sensor circuit is open or shorted to ground
31	Engine preheater circuit is open or shorted to ground
32	Travel alarm buzzer circuit is open or shorted to ground
33	Alternator circuit is open or shorted to ground
34	Controller input voltage is below 18V
35	Controller input voltage is over 38V
36	Communication error with cluster
37	Engine speed sensor circuit is open or shorted to ground
38	Anti-restart relay circuit is open or shorted to ground
39	Accel actuator does not stop at a target position
40	There is more than 500rpm difference between target speed and actual speed

Fault code No.	Description
41	Hydraulic oil temperature sensor circuit is shorted to ground
42	Fuel level sensor circuit is shorted to ground
43	Coolant temperature sensor circuit is shorted to ground
44	Boom up pressure sensor circuit is shorted to power supply(24V) line
45	Hydraulic oil temperature sensor circuit is open or shorted to battery +
46	Fuel level sensor circuit is open or shorted to battery +
47	Coolant temperature sensor circuit is open or shorted to battery +
48	Boom up pressure sensor circuit is open or shorted to ground
49	Engine preheater circuit is shorted to battery +
51	Boom priority solenoid circuit is open or shorted to ground
56	Travel alarm buzzer circuit is shorted to battery +
58	Boom priority solenoid circuit is shorted to battery +

GROUP 10 ENGINE CONTROL SYSTEM

1. MCU MOUNTING

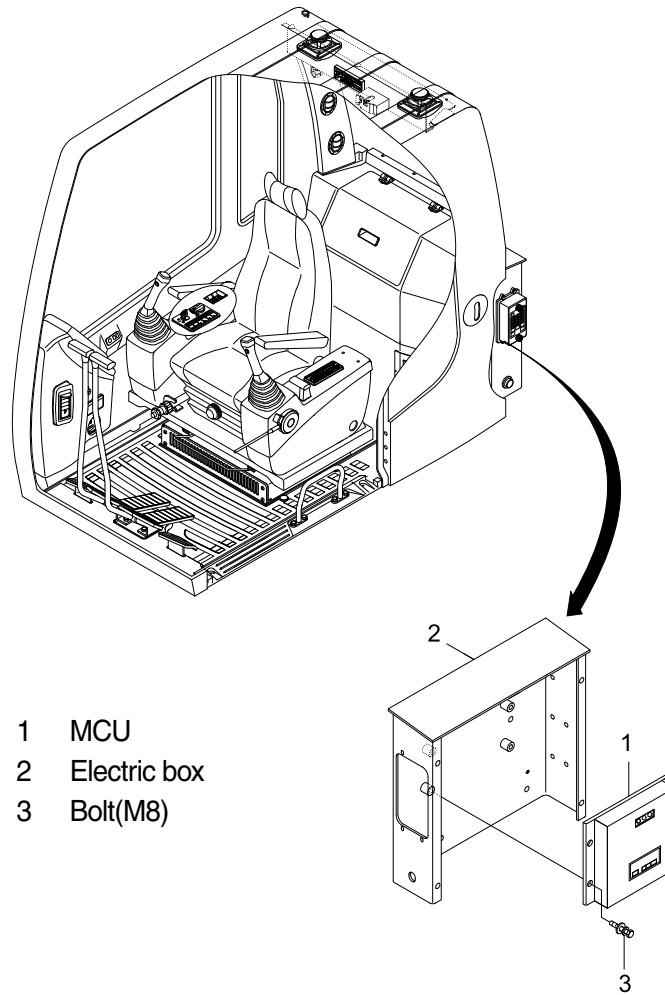

2. MCU ASSEMBLY

- 1) Remove four pieces of bolt(3) of electric box(2).
- 2) Disconnect 2 connectors from MCU.
- 3) Remove 6 pieces of screw and open the cover of MCU.
- 4) Inspection : Check PCB(Printed Circuit Board)
 - (1) If any damage is found, replace MCU assembly.
 - (2) If not, but CAPO system does not work please report it to HHI dealer or A/S department.

3. EXCHANGE METHOD OF THE ROM

- 1) Disassemble the ash tray(2).
- 2) Disassemble the wiper motor cover(3).
- 3) Disassemble the cluster(1).

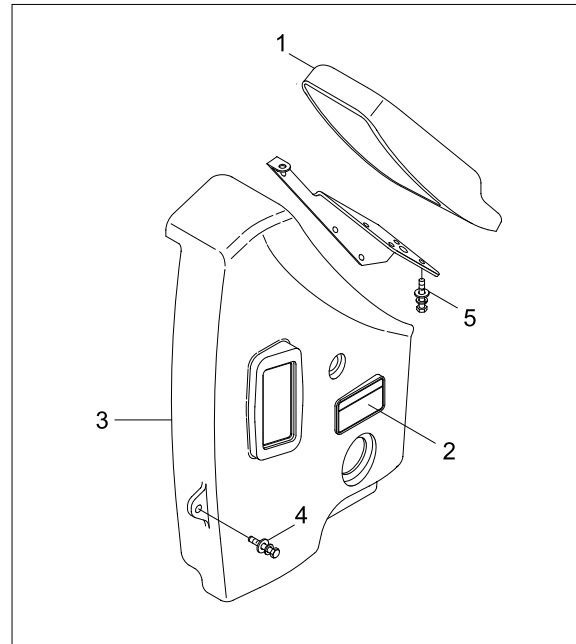

- 4) Loosen the screws(6EA) located back of the cluster.
- 5) Then you can open the upper case of the cluster easily.

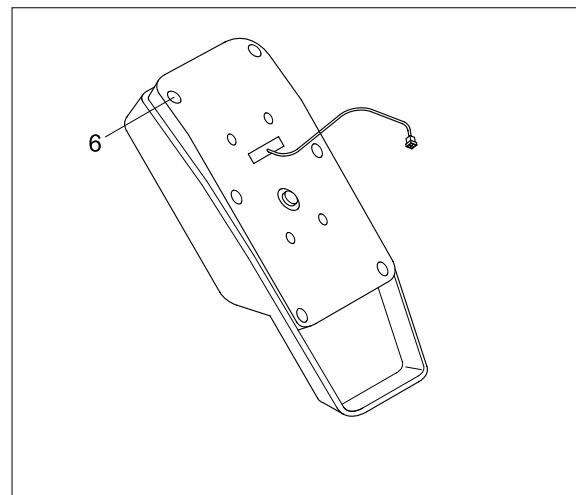

- 6) Install the new ROM.(Be careful of direction and assmelbe the cluster in the reverse order to removal).

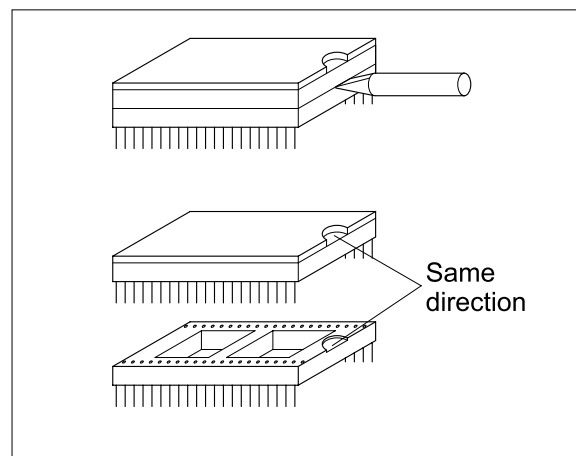

4. ENGINE ACCEL ACTUATOR

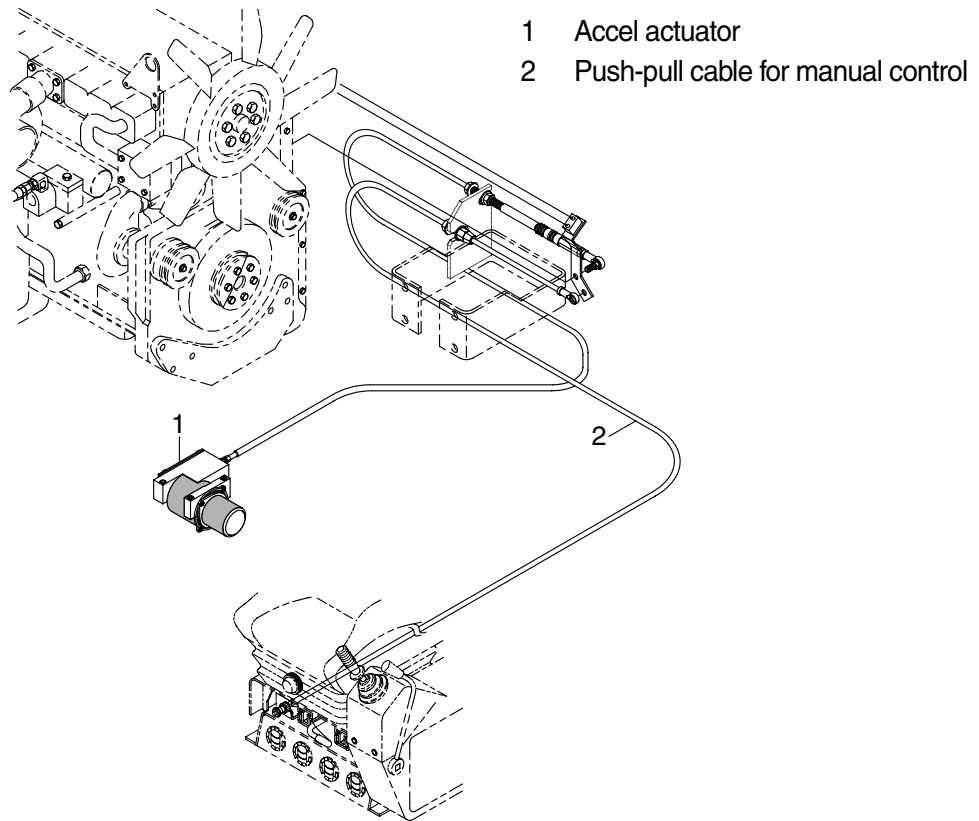

1) ENGINE THROTTLE LEVER

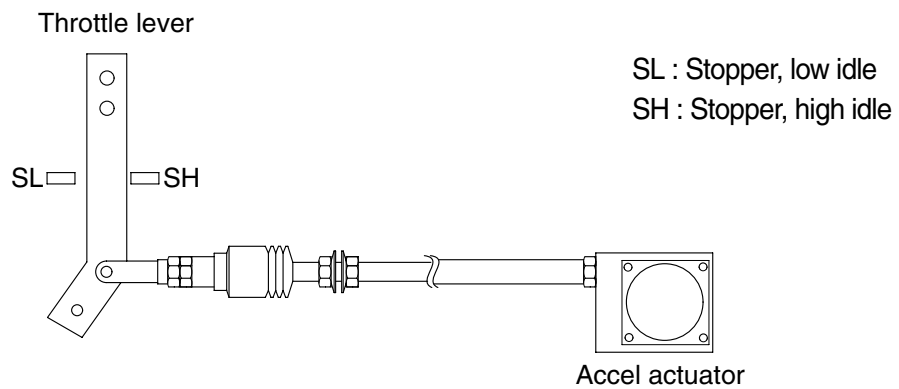

2) EMERGENCY CABLE (Push-pull cable)

It controls engine speed by connecting onto the lever of the injection pump when the malfunction of the MCU or the accel actuator happen.

3) ACCEL ACTUATOR

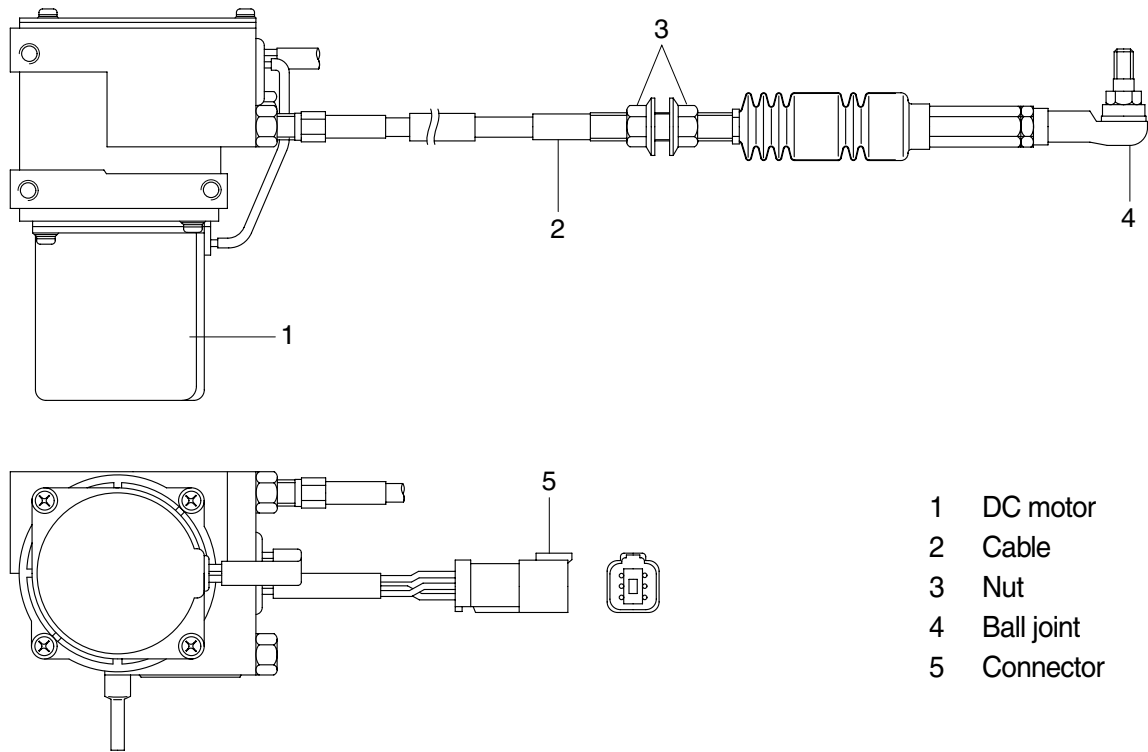

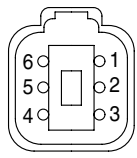
Connector		
Type	6P, female	
Line color & description	1	White(Potentiometer 5V)
	2	Blue(Potentiometer SIG)
	3	Black(Potentiometer GND)
	4	-
	5	Green(Motor+)
	6	Yellow(Motor -)
Inspection	Check resistance Spec : 1~2 Ω (Between No.5-6) 0.8~1.2kΩ (Between No.1-3)	

4) ACCEL ACTUATOR CABLE SETTING PROCEDURE

(1) Key OFF

- ① Connect the ball joint of cable to engine throttle lever.
- ② Pull the cable to high stopper and put nut **A** edge to yoke of the bracket.
 - ※ Make throttle lever not contact to the edge of high stopper.
- ③ Turn nut **A** to clockwise until touching to the edge of high stopper.
- ④ Make 1 turn more to clockwise in condition of the nut **A** contact to the edge of high stopper.

(2) Key START

- ⑤ Confirm if the engine speed on cluster is same as each mode specification.
- ⑥ If the engine speed displayed on cluster is higher than each mode specification, then turn the nut **A** to counter clockwise and make the engine speed same to each mode specification.
- ⑦ If the engine speed displayed on cluster is lower than each mode specification, then turn the nut **A** to clockwise and make the engine speed same to each mode specification.
- ⑧ Turn nut **B** to clockwise and fix the cable to bracket.

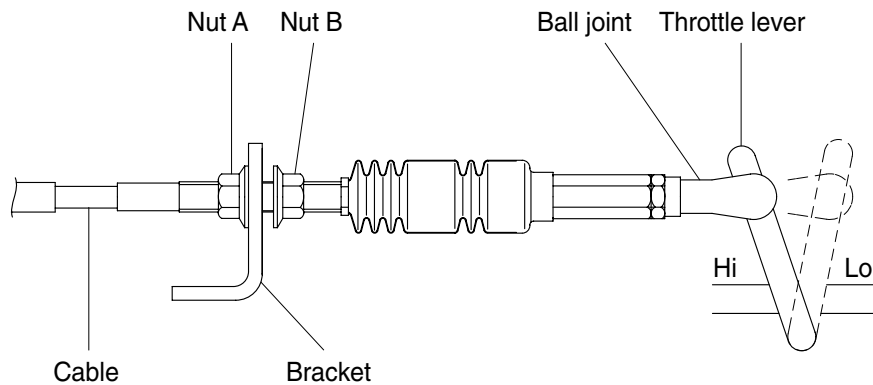

Mode	RPM
P	2100 ± 50
S	1950 ± 50
E	1800 ± 50
Auto decel	1200 ± 100
Key start	950 ± 100

5. ENGINE SPEED SENSOR

1) DETECT ACTUAL ENGINE RPM AND SEND SIGNAL TO TACHOMETER

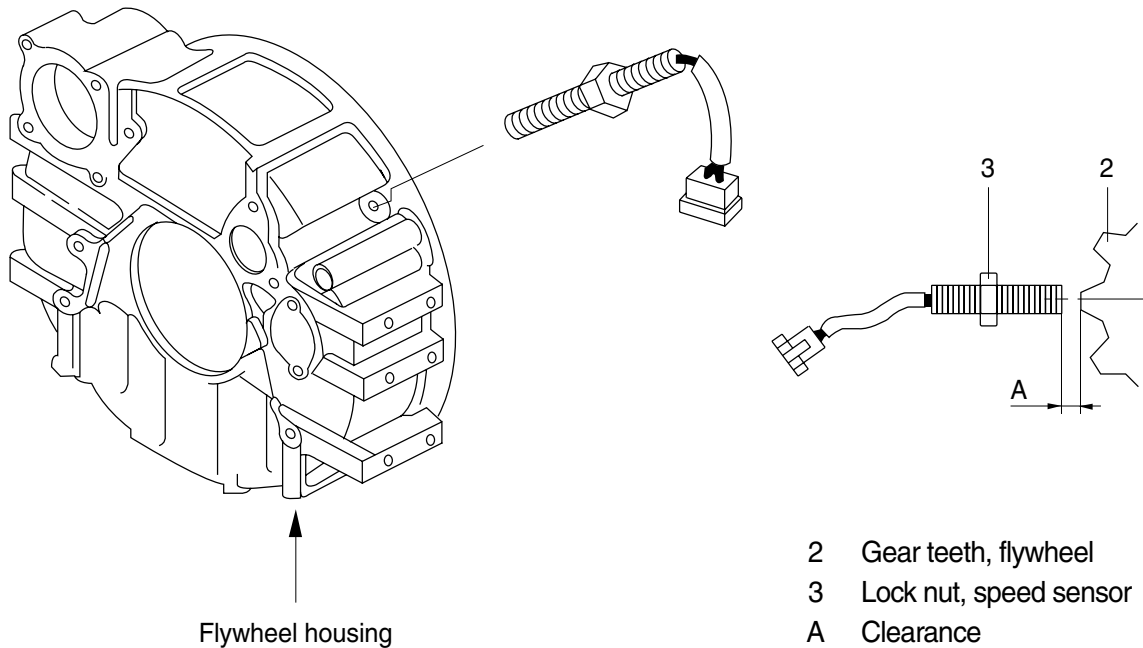

2) INSTALLATION

- (1) Clean contacting point of sensor.
- (2) Loosen lock nut.
- (3) Screw speed sensor into flywheel housing.
- (4) Turn it back 135° when it contacts with gear teeth.
- (5) Tight lock nut and connect wiring.

3) INSPECTION

- (1) Check resistance
 - SPEC : 300 Ω
- (2) Check voltage while engine run.
 - SPEC : 2~28Vac, dependent on the engine speed(rpm)

GROUP 11 EPPR VALVE

1. COMPOSITION OF EPPR VALVE

EPPR(Electro Proportional Pressure Reducing) valve consists of electro magnet and spool valve installed at main hydraulic pump.

1) ELECTRO MAGNET VALVE

Receive electric current from MCU and move the spool proportionally according to the specific amount of electric current value.

2) SPOOL VALVE

Is the two way direction control valve for pilot pressure to reduce hydraulic pump flow.

When the electro magnet valve is activated, pilot pressure enters into flow regulator of hydraulic pump. So, pump flow decreases to prevent engine stall.

3) PRESSURE AND ELECTRIC CURRENT VALUE FOR EACH MODE

Mode		Pressure		Electric current (mA)	Engine rpm (At accel dial 10)
		kgf/cm ²	psi		
Standard (Ver : 3.1)	P	8 ± 3	114 ± 40	290 ± 30	2100 ± 50
	S	12 ± 3	171 ± 40	360 ± 30	1950 ± 50
	E	15 ± 3	213 ± 40	400 ± 30	1800 ± 50
Option (Ver : 4.1)	P	5 ± 3	71 ± 40	250 ± 30	2150 ± 50
	S	7 ± 3	100 ± 40	280 ± 30	2000 ± 50
	E	10 ± 3	142 ± 40	330 ± 30	1850 ± 50

2. HOW TO SWITCH THE VERSION(3.1↔ 4.1) ON THE CLUSTER

You can switch the EPPR valve pressure set by selecting the version(3.1 ↔ 4.1).

- Dual mode
 - Changing the MCU mode



2. OPERATING PRINCIPLE

1) STRUCTURE

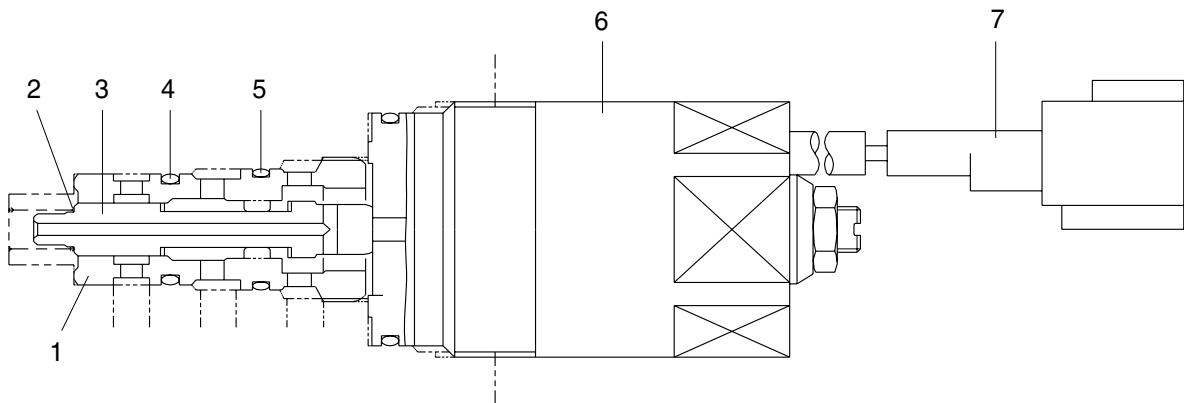

5-22(1)

- 1 Sleeve
- 2 Spring
- 3 Spool

- 4 O-ring
- 5 O-ring

- 6 Solenoid valve
- 7 Connector

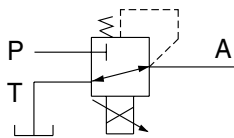

P Pilot oil supply line(Pilot pressure)

T Return to tank

A Secondary pressure to flow regulator at hydraulic pump

2) AT H MODE

Pressure line is blocked and A oil returns to tank.

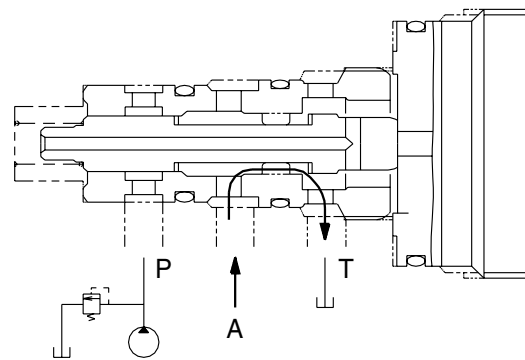
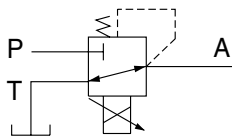

3) AT S MODE

Secondary pressure enters into A.

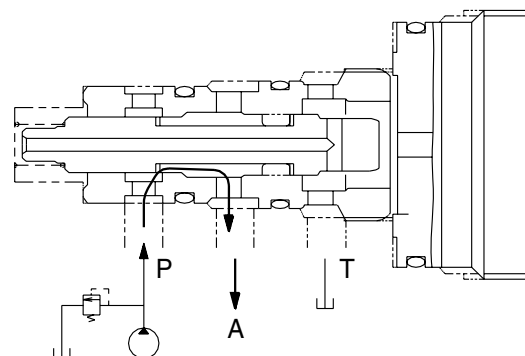
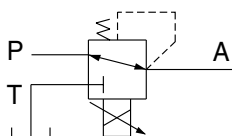

5-22(2)

3. EPPR VALVE CHECK PROCEDURE

1) CHECK ELECTRIC VALUE AT EPPR VALVE

- (1) Start engine.
- (2) Set S-mode and cancel auto decel mode.
- (3) Position the accel dial at 10.
- (4) If tachometer show approx 1950 ± 50 rpm, disconnect one wire harness from EPPR valve.
- (5) Install multimeter as figure.
- (6) Check electric current at bucket circuit relief position.

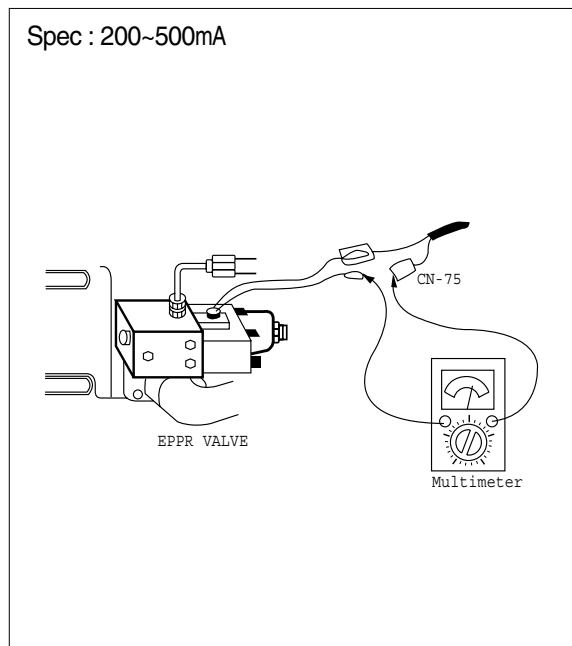

2) CHECK PRESSURE AT EPPR VALVE

- (1) Remove plug and connect pressure gauge as figure.
 - Gauge capacity : 0 to 40-50kgf/cm²
(0 to 580-725psi)
- (2) Start engine.
- (3) Set S-mode and cancel auto decel mode.
- (4) Position the accel dial at 10.
- (5) If tachometer show approx 1950 ± 50 rpm, check pressure at relief position of bucket circuit by operating bucket control lever.
- (6) If pressure is not correct, adjust it.
- (7) After adjust, test the machine.

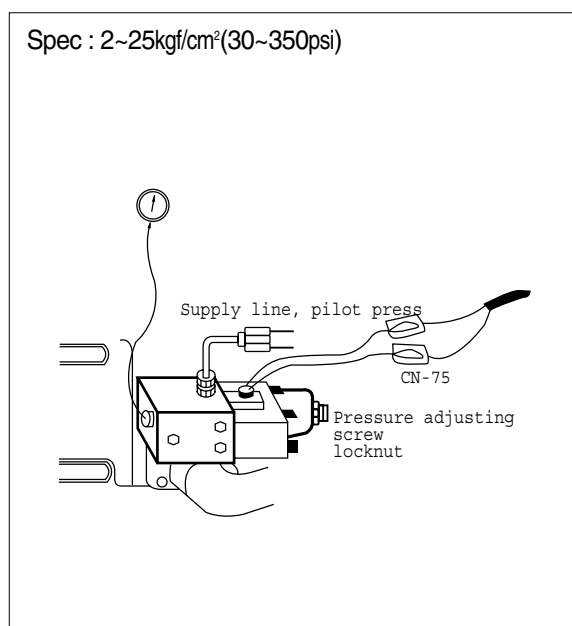

GROUP 12 MONITORING SYSTEM

1. OUTLINE

Monitoring system consists of the monitor part and switch part.

The monitor part gives warnings when any abnormality occurs in the machine and informs the condition of the machine.

Various select switches are built into the monitor panel, which act as the control portion of the machine control system.

2. CLUSTER

1) MONITOR PANEL

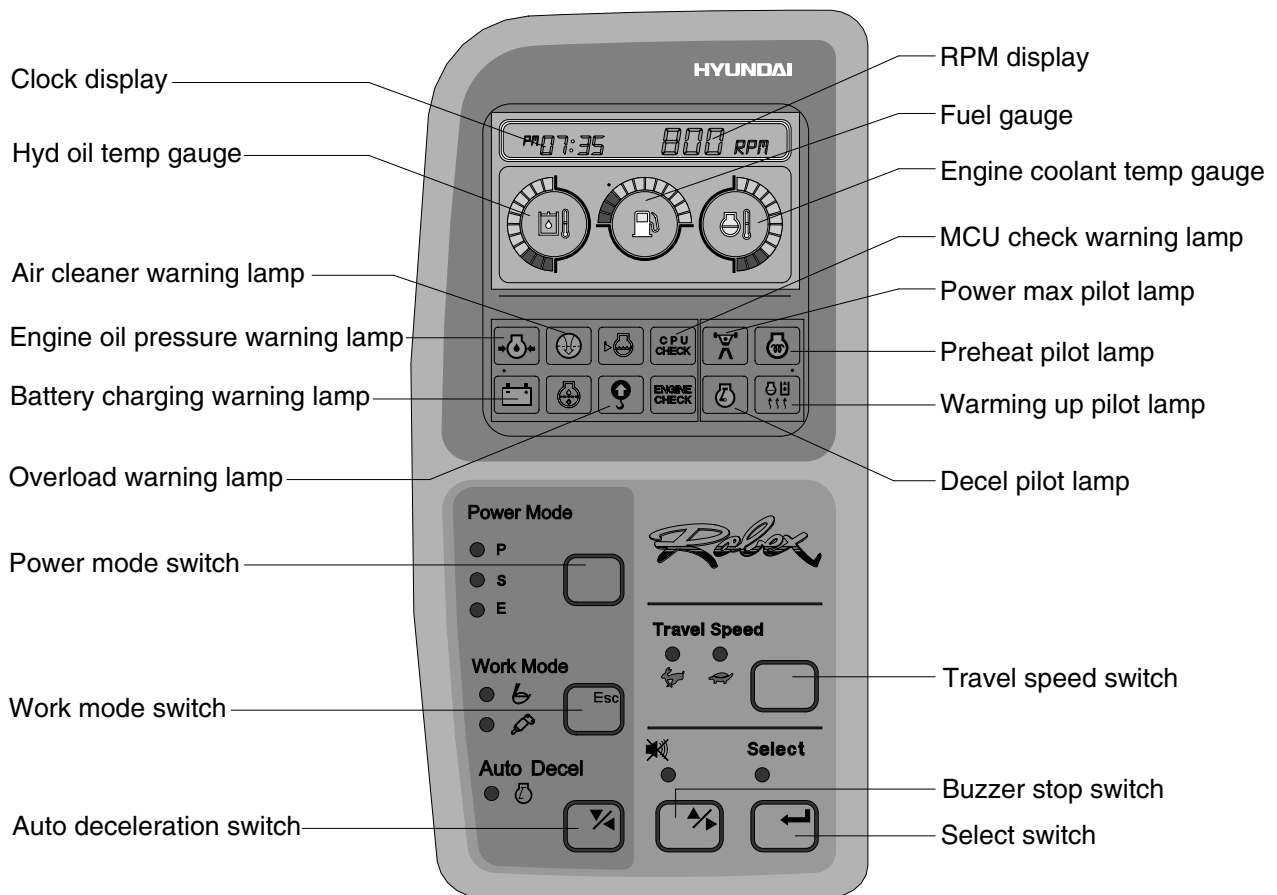

140V95MS06

2) CLUSTER CHECK PROCEDURE

(1) Start key : ON

- ① Check monitor initial 5 seconds
 - a. All lamps light up.
 - b. Buzzer sound.
- ② Check monitor after 5 seconds : Indicate cluster version and machine condition
 - a. Cluster program version : 「1.00」 ← Indicates program version 「1.00」 for 5 seconds.
 - b. Tachometer : 0rpm
 - c. Fuel gauge : All light up below appropriate level
 - d. Hydraulic temperature : All light up below appropriate level
 - e. Engine coolant temperature gauge : All light up below appropriate level
 - f. Warning lamp
 - ※ During start key **ON** the engine oil pressure lamp and battery charging lamp go on, but it is not abnormal.
 - ※ When engine coolant temperature below 30°C, the warming up lamp lights up.
- ③ Indicating lamp state
 - a. Work mode selection : General work
 - b. Power mode selection : S mode
 - c. User mode selection : No LED ON
 - d. Auto decel LED : ON
 - e. Travel speed pilot lamp : Low(Turtle)

(2) Start of engine

- ① Check machine condition
 - a. Tachometer indicates at present rpm
 - b. Gauge and warning lamp : Indicate at present condition.
 - ※ When normal condition : All warning lamp OFF
 - c. Work mode selection : General work
 - d. Power mode selection : S mode
 - e. User mode selection : No LED ON
 - f. Auto decel LED : ON
 - g. Travel speed pilot lamp : Low(Turtle)
- ② When warming up operation
 - a. Warming up lamp : ON
 - b. 10 seconds after engine started, engine speed increases to 1200rpm(Auto decel LED : ON)
 - ※ Others same as above ①.
- ③ When abnormal condition
 - a. The lamp lights up and the buzzer sounds.
 - b. If **BUZZER STOP** switch is pressed, buzzer sound is canceled but the lamp light up until normal condition.

3. CLUSTER CONNECTOR

No.	Signal	Input / Output
1	Power IG(24V)	Input(20~32V)
2	GND	Input(0V)
3	Serial-(RX)	Input(Vpp=12V)
4	Serial+(TX)	Output(Vpp=4V)

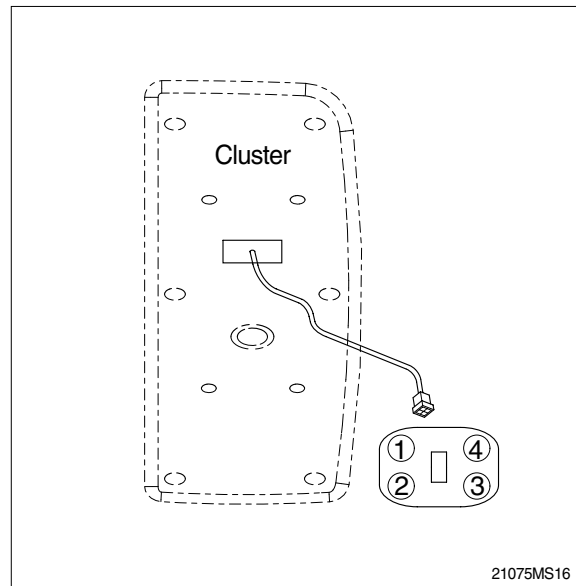

2) LCD main operation display

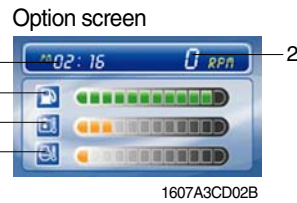
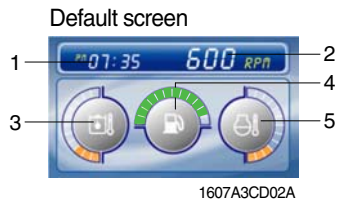

- 1 Time display
- 2 RPM display
- 3 Hydraulic oil temperature gauge
- 4 Fuel level gauge
- 5 Engine coolant temperature gauge

(1) Time display



- ① This displays the current time.

※ Refer to the page 5-36 to set time for details.

(2) RPM display



- ① This displays the engine rpm.

(3) Hydraulic oil temperature gauge

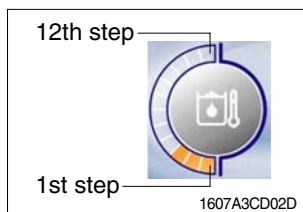

- ① This gauge indicates the temperature of hydraulic oil in 12 step gauge.

- 1st step : Below 30°C(86°F)
- 2nd~10th step : 30-105 °C(86-221°F)
- 11th~12th step : Above 105°C(221°F)

- ② The gauge between 2nd and 10th steps illuminates when operating.

- ③ Keep idling engine at low speed until the gauge between 2nd and 10th steps illuminates, before operation of machine.

- ④ When the gauge of 11th and 12th steps illuminates, reduce the load on the system. If the gauge stays in the 11th~12th steps, stop the machine and check the cause of the problem.

(4) Fuel level gauge

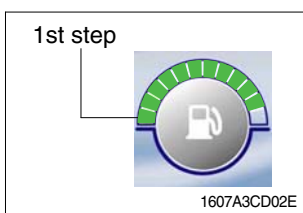

- ① This gauge indicates the amount of fuel in the fuel tank.

- ② Fill the fuel when the 1st step or fuel icon blinks in red.

※ If the gauge illuminates the 1st step or fuel icon blinks in red even though the machine is on the normal condition, check the electric device as that can be caused by the poor connection of electricity or sensor.

(5) Engine coolant temperature gauge

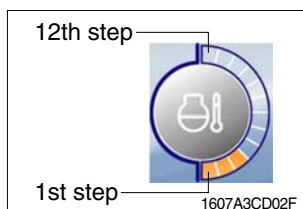

- ① This gauge indicates the temperature of coolant in 12 step gauge.

- 1st step : Below 30°C(86°F)
- 2nd~10th step : 30-105 °C(86-221°F)
- 11th~12th step : Above 105°C(221°F)

- ② The gauge between 2nd and 10th steps illuminates when operating.

- ③ Keep idling engine at low speed until the gauge between 2nd and 10th steps illuminates, before operation of machine.

- ④ When the gauge of 11th and 12th steps illuminates, turn OFF the engine, check the radiator and engine.

3) Warning of main operation screen

(1) Warning display

① Engine coolant temperature



- This lamp blinks and the buzzer sounds when the temperature of coolant is over the normal temperature 105°C (221°F) .
- Check the cooling system when the lamp blinks.

② Fuel level



- This lamp blinks and the buzzer sounds when the level of fuel is below 31 l (8.2U.S. gal).
- Fill the fuel immediately when the lamp blinks.

③ Hydraulic oil temperature



- This warning lamp operates and the buzzer sounds when the temperature of hydraulic oil is over 105 °C (221 °F) .
- Check the hydraulic oil level when the lamp blinks.
- Check for debris between oil cooler and radiator.

④ All gauge



- This lamp blinks and the buzzer sounds when the all gauge is abnormal.
- Check the each system when the lamp blinks.

⑤ Communication error



- Communication problem between MCU and cluster makes the lamp blinks and the buzzer sounds.
- Check if any fuse for MCU burnt off.
If not check the communication line between them.





(2) Pop-up icon display

No	Switch	Selected mode	Display
1	Work mode switch	General work mode	
		Heavy duty work mode	
		Breaker operation mode	
2	Power mode switch	High power work mode	
		Standard power work mode	

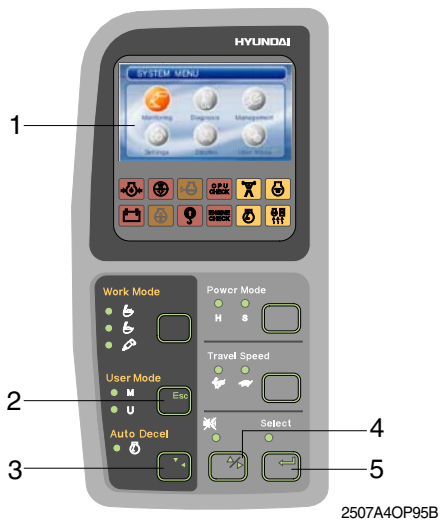
No	Switch	Selected mode	Display
3	Auto deceleration switch	Light ON	
		Light OFF	
4	Travel speed control switch	Low speed	
		High speed	







4) LCD

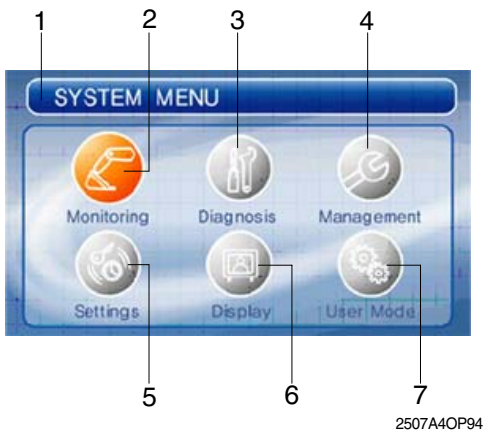

- 1  : LCD
- 2  : Escape,
Return to the previous menu
- 3  : Down/Left Direction
- 4  : Up/Right Direction
- 5  : Select(Enter)
Activate the currently chosen item

(1) Main menu



- 1  : Menu information
- 2  : Monitoring
- Equipment, Switch, Output
- 3  : Diagnosis
- Current error, Recorded error
- 4  : Maintenance
- 5  : Settings
- Time set, Dual mode
- System lock(Reserved)
- 6  : Display
- Operation skin, Brightness, Language
- 7  : User mode

(2) Display map

① Monitoring

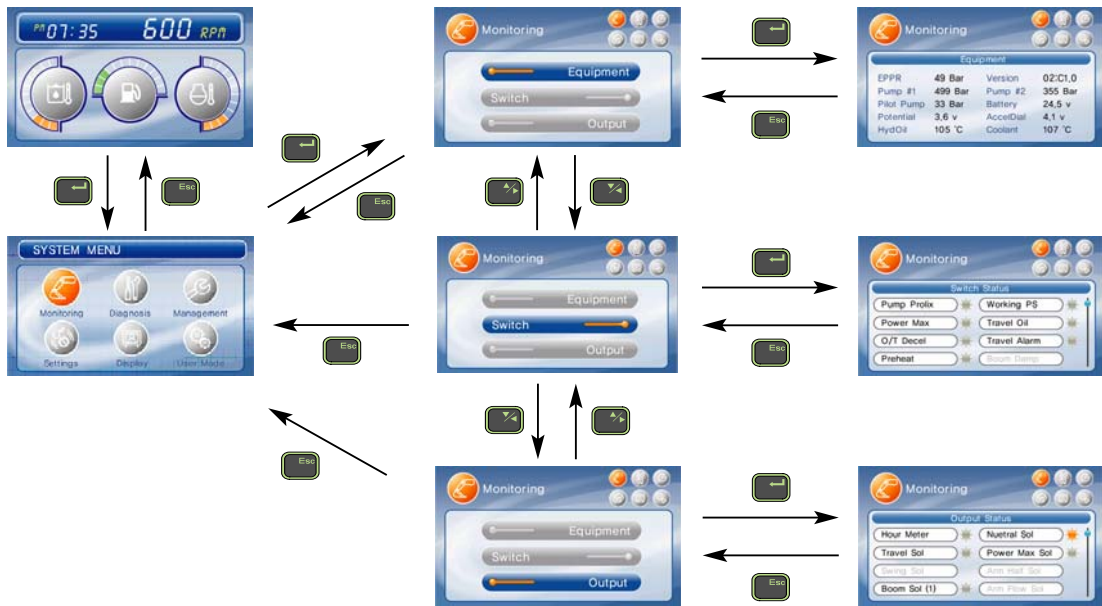

② Diagnosis

a. Protocol type 1

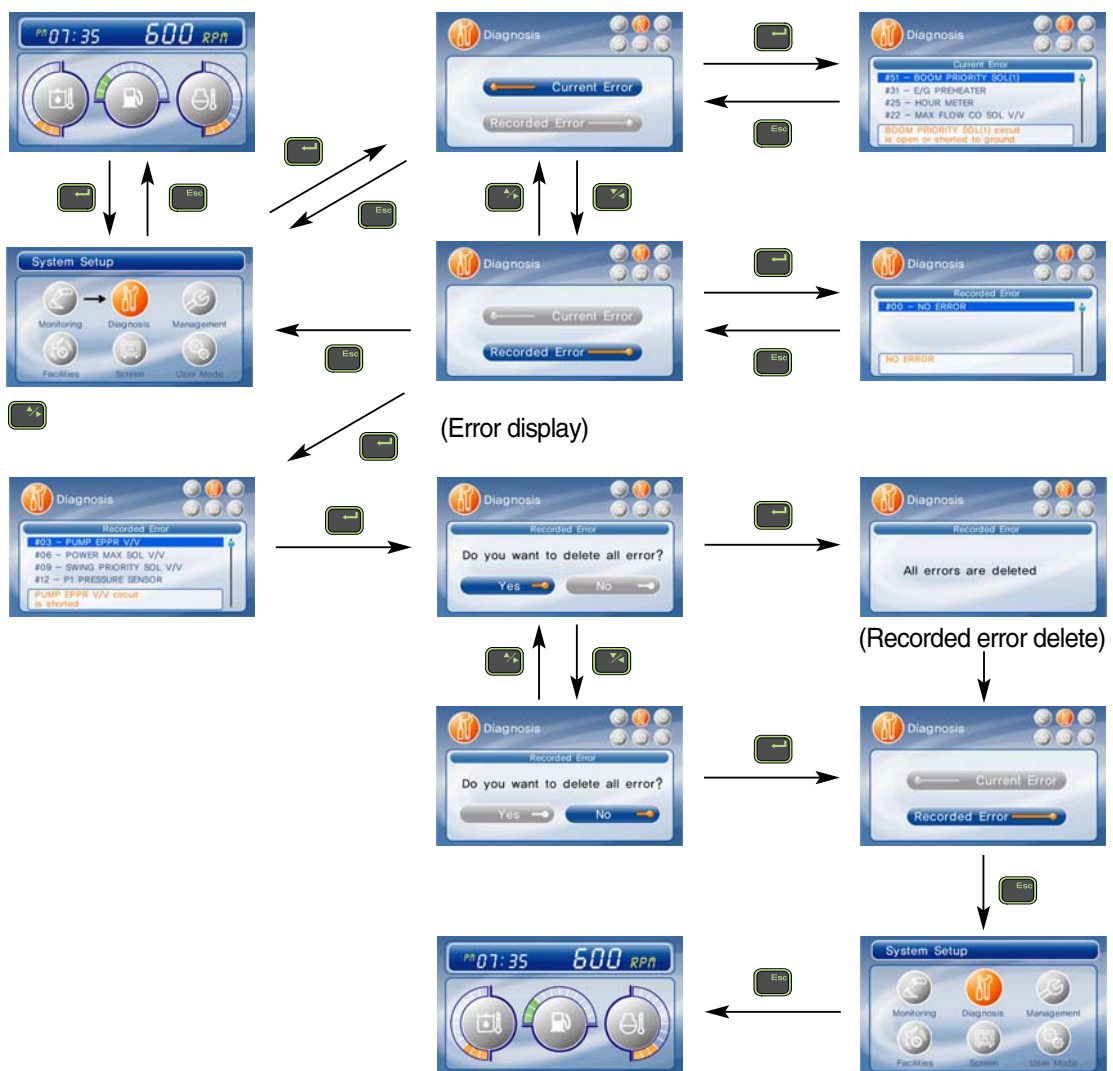

b. Protocol type 2

- If there are more than 2 error codes, each one can be displayed by pressing or switch respectively.
- 3 error codes (①SPN200200, ②FMI06, ③SPN6789, ④FMI04, ⑤345) display.

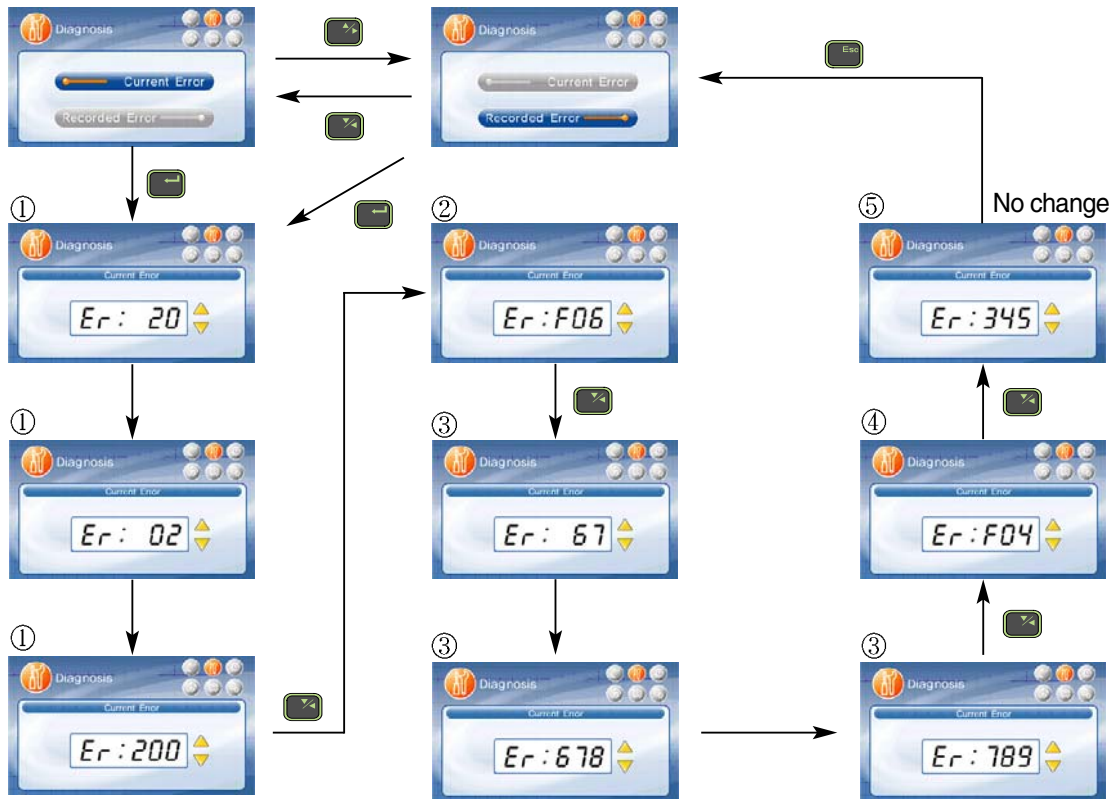

③ Maintenance

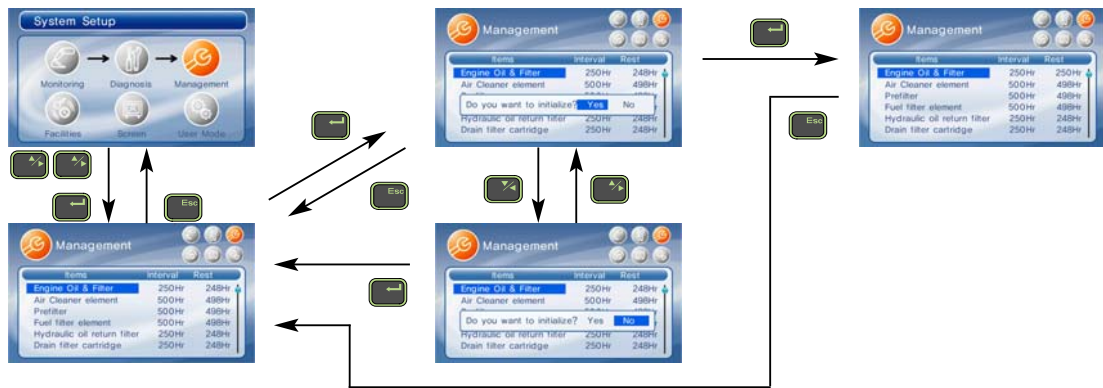

④ Setting

a. Time set



b. System lock - Reserved

c. Dual mode
- Changing the MCU mode



⑤ Display

a. Operation skin



b. Brightness

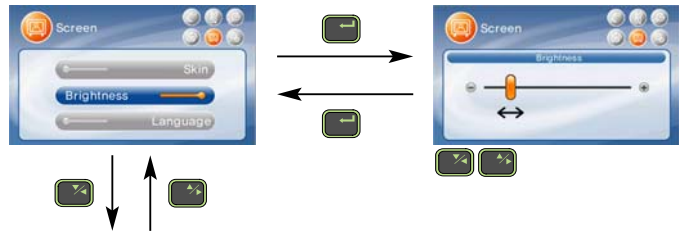

c. Language

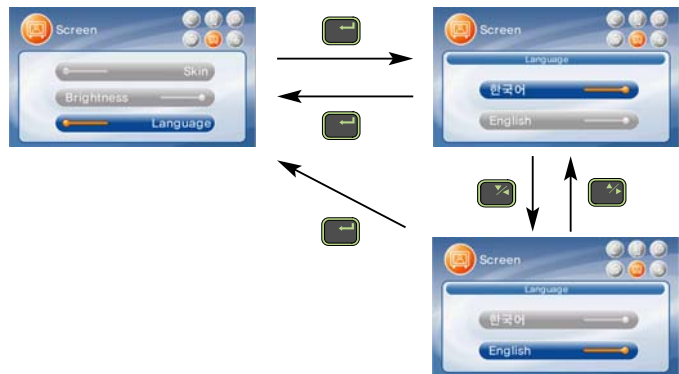

⑥ User mode

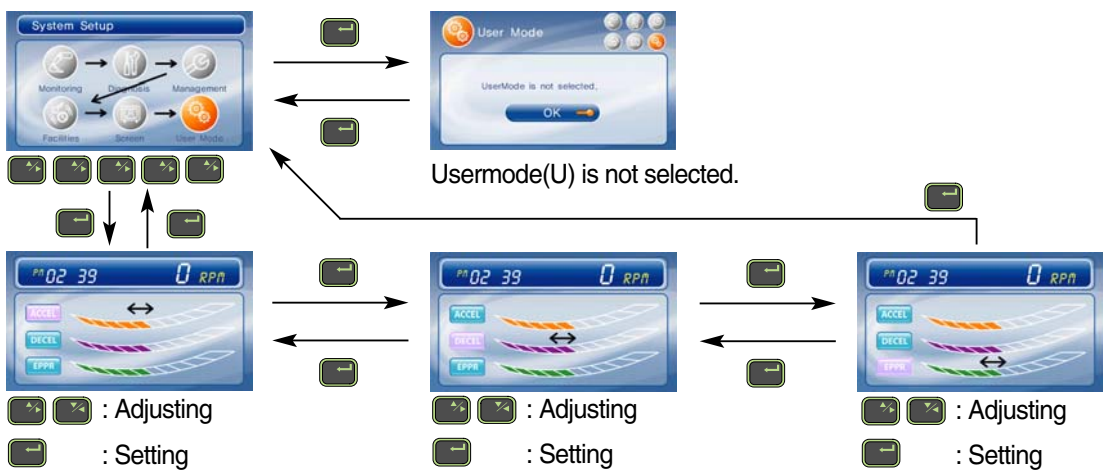

5) Warning and pilot lamp

(1) Engine oil pressure warning lamp

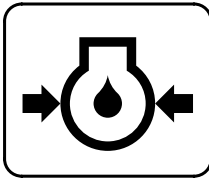

21073CD07

- ① This lamp blinks and the buzzer sounds after starting the engine because of the low oil pressure.
- ② If the lamp blinks during engine operation, shut OFF engine immediately. Check oil level.

(2) Air cleaner warning lamp

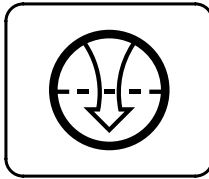

21073CD08

- ① This lamp blinks and the buzzer sounds when the filter of air cleaner is clogged.
- ② Check the filter and clean or replace it.

(3) MCU check warning lamp

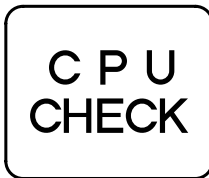

21073CD10

- ① If any fault code is received from MCU, this lamp blinks and the buzzer sounds.
- ② Check the communication line between MCU and cluster.

(4) Battery charging warning lamp

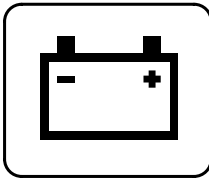

21073CD13

- ① This lamp blinks and the buzzer sounds when the starting switch is ON, it is turned OFF after starting the engine.
- ② Check the battery charging circuit when this lamp blinks during engine operation.

(5) Overload warning lamp

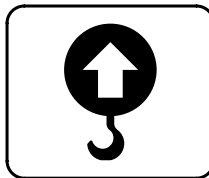

21073CD15

- ① When the machine is overload, the overload warning lamp blinks during the overload switch is ON.

(6) Power max pilot lamp

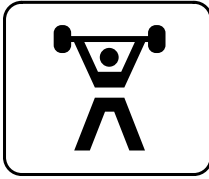

21073CD11

- ① The lamp will be ON when pushing power max switch on the LH RCV lever.

(7) Decel pilot lamp

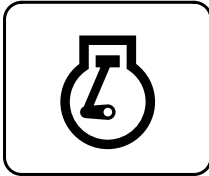

21073CD17

- ① Operating auto decel or one touch decel makes the lamp ON.
- ② The lamp will be ON when pushing one touch decel switch on the LH RCV lever.

(8) Warming up pilot lamp

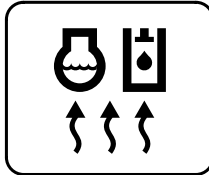

21073CD18

- ① This lamp is turned ON when the coolant temperature is below 30°C (86 °F).
- ② The automatic warming up is cancelled when the engine coolant temperature is above 30 °C, or when 10 minutes have passed since starting.

(9) Preheat pilot lamp

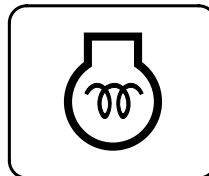

21073CD12

- ① Turning the start key switch ON position starts preheating in cold weather.
- ② Start the engine as this lamp is OFF.