

GROUP 3 TRACK AND WORK EQUIPMENT

1. TRACK

1) TRACK ROLLER

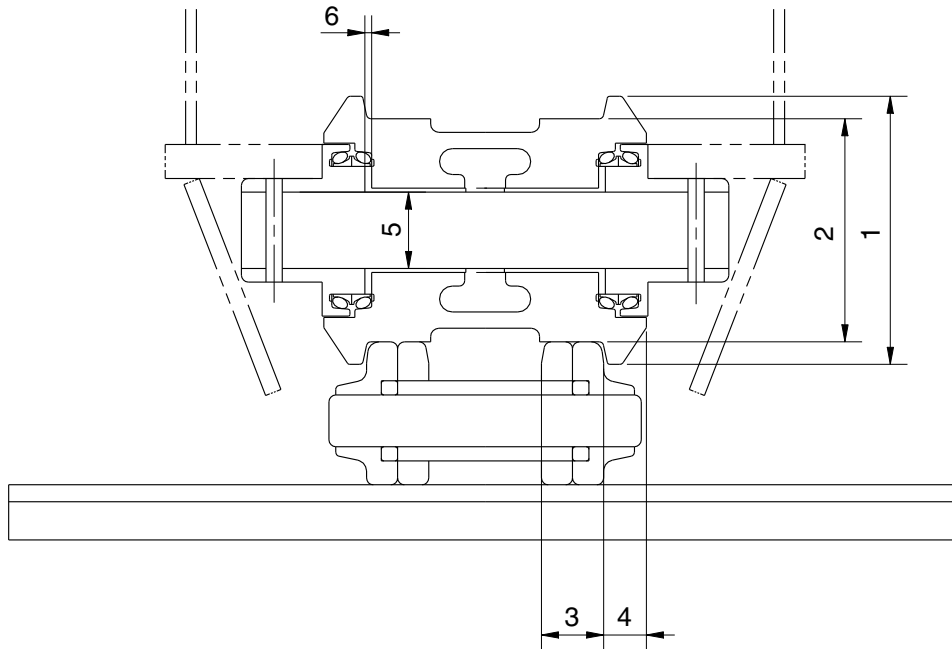

21037MS01

Unit : mm

No.	Check item	Criteria				Remedy
		Standard size		Repair limit		
1	Outside diameter of flange	ø 190		-		Rebuild or replace
2	Outside diameter of tread	ø 150		ø 138		
3	Width of tread	36.5		42.5		
4	Width of flange	26.5		-		
5	Clearance between shaft and bushing	Standard size ø 65	tolerance		Standard clearance 0.325 to 0.47	Clearance limit 2.0
			Shaft	Hole		
			-0.25 -0.35	+0.12 +0.075		
6	Side clearance of roller (both side)	Standard clearance		Clearance limit		Replace
		0.1 to 1.3		2.0		

2) CARRIER ROLLER

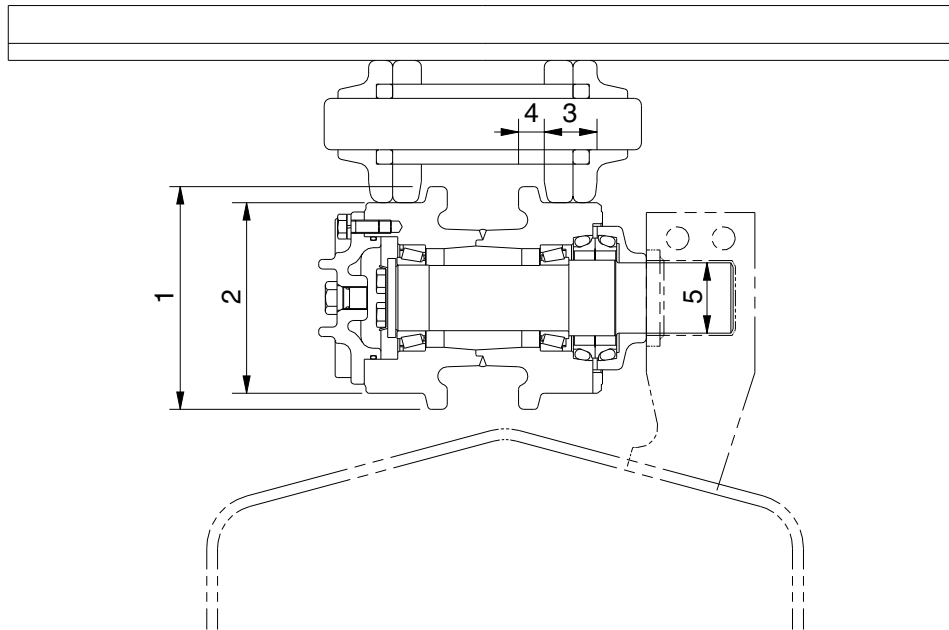

21037MS02

Unit : mm

No.	Check item	Criteria			Remedy	
		Standard size		Repair limit		
1	Outside diameter of flange	ø 175		-	Rebuild or replace	
2	Outside diameter of tread	ø 151		ø 141		
3	Width of tread	37.25		42.25		
4	Width of flange	18.25		-		
5	Clearance between shaft and bushing	Standard size & Tolerance		Standard clearance	Clearance limit	Replace bushing
		Shaft	Hole			
		ø 41.27 ⁰ / _{+0.05}	ø 41.5 ^{+0.2} / _{-0.1}	0.13 to 0.48	1.2	

3) IDLER

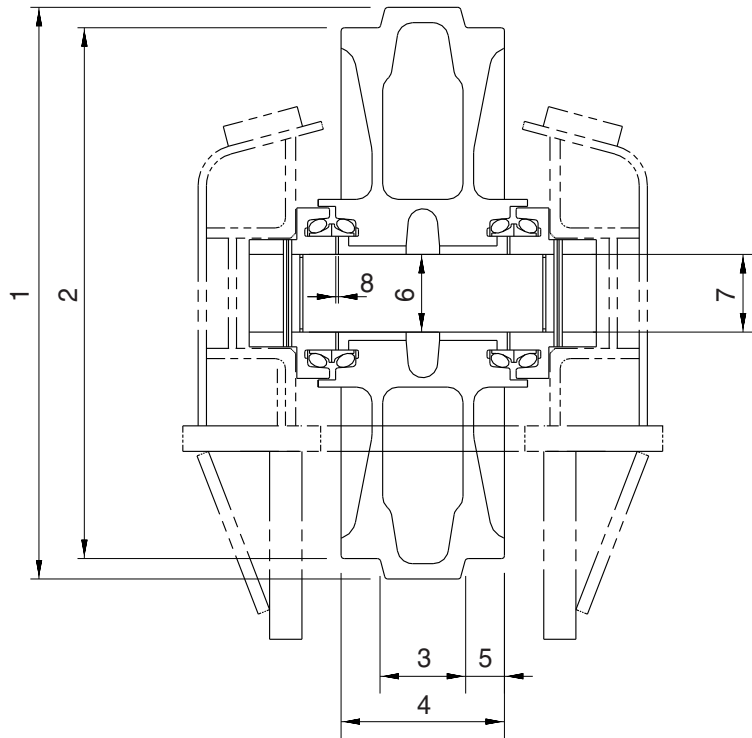

21037MS03

Unit : mm

No.	Check item	Criteria				Remedy
		Standard size		Repair limit		
1	Outside diameter of flange	ø 552		-		Rebuild or replace
2	Outside diameter of tread	ø 507		ø 497		
3	Width of protrusion	67		-		
4	Total width	135		-		
5	Width of tread	34		39		
6	Clearance between shaft and bushing	Standard size & Tolerance		Standard clearance	Clearance limit	Replace bushing
		Shaft	Hole			
		ø 70 $\begin{matrix} 0 \\ -0.03 \end{matrix}$	ø 70.3 $\begin{matrix} +0.05 \\ 0 \end{matrix}$	0.3 to 0.38	2.0	
7	Clearance between shaft and support	ø 70 $\begin{matrix} 0 \\ -0.03 \end{matrix}$	ø 70 $\begin{matrix} +0.07 \\ +0.03 \end{matrix}$	0.3 to 0.1	1.2	Replace
8	Side clearance of idler (both side)	Standard clearance		Clearance limit		Replace bushing
		0.25 to 1.15		2.0		

4) TRACK

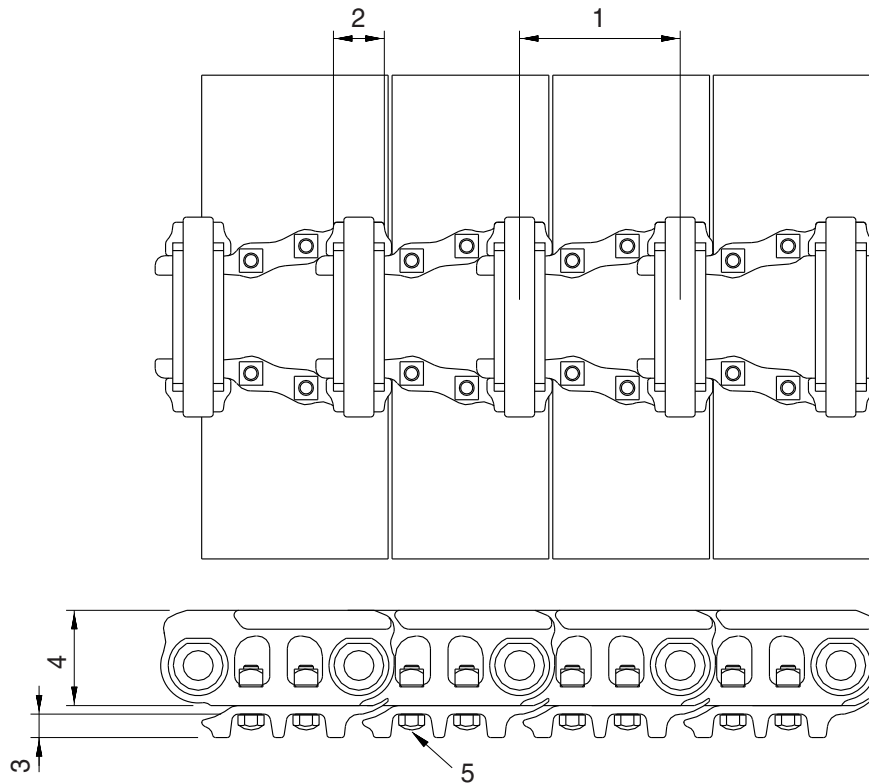

21037MS04

Unit : mm

No.	Check item	Criteria		Remedy
		Standard size	Repair limit	
1	Link pitch	171.45	175.65	Turn or replace
2	Outside diameter of bushing	∅ 53.75	∅ 43.95	
3	Height of grouser	25	16	Rebuild or replace
4	Height of link	94.5	86.5	
5	Tightening torque (Tightening angle method)	Initial tightening torque : $42 \pm 4 \text{ kgf} \cdot \text{m}$ Additional tightening angle : 32°		Retighten

5) TRACK FRAME AND RECOIL SPRING

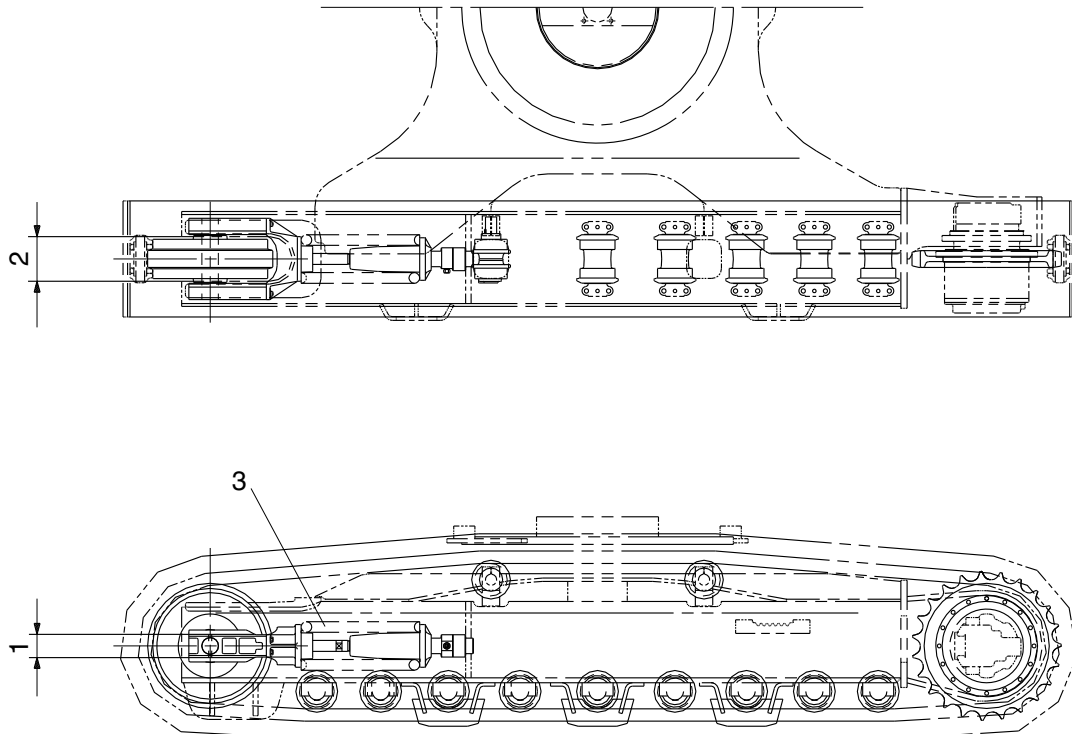

21037MS05

Unit : mm

No.	Check item	Criteria				Remedy	
			Standard size	Tolerance	Repair limit		
1	Vertical width of idler guide	Track frame	103	+2 0	107	Rebuild or replace	
		Idler support	100	0 -0.5	98		
2	Horizontal width of idler guide	Track frame	192	+2 0	196		
		Idler support	190	-	188		
3	Recoil spring	Standard size			Repair limit		Replace
		Free length	Installation length	Installation load	Free length	Installation load	
		∅ 192 × 470	405	8,497kg	-	6,978kg	

2. WORK EQUIPMENT

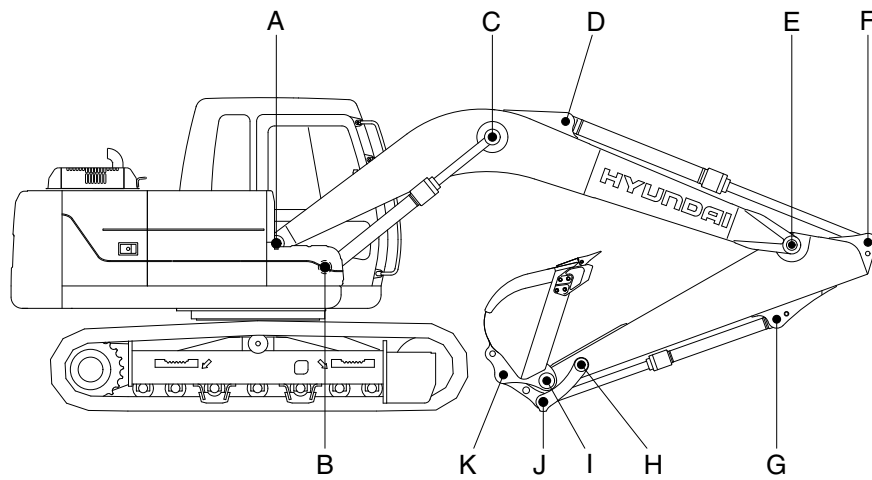

14097MS01

Unit : mm

Mark	Measuring point (Pin and Bushing)	Normal value	Pin		Bushing		Remedy & Remark
			Recomm. service limit	Limit of use	Recomm. service limit	Limit of use	
A	Boom Rear	70	69	68.5	70.5	71	Replace
B	Boom Cylinder Head	70	69	68.5	70.5	71	"
C	Boom Cylinder Rod	70	69	68.5	70.5	71	"
D	Arm Cylinder Head	70	69	68.5	70.5	71	"
E	Boom Front	70	69	68.5	70.5	71	"
F	Arm Cylinder Rod	70	69	68.5	70.5	71	"
G	Bucket Cylinder Head	70	69	68.5	70.5	71	"
H	Arm Link	65	64	63.5	65.5	66	"
I	Bucket and Arm Link	65	64	63.5	65.5	66	"
J	Bucket Cylinder Rod	70	69	68.5	70.5	71	"
K	Bucket Link	65	64	63.5	65.5	66	"