

GROUP 5 SWING DEVICE

1. REMOVAL AND INSTALL OF MOTOR

1) REMOVAL

- (1) Lower the work equipment to the ground and stop the engine.
- (2) Operate the control levers and pedals several times to release the remaining pressure in the hydraulic piping.
- (3) Loosen the breather slowly to release the pressure inside the hydraulic tank.

▲ Escaping fluid under pressure can penetrate the skin causing serious injury.

※ When pipes and hoses are disconnected, the oil inside the piping will flow out, so catch it in oil pan.

- (4) Disconnect hose assembly (2).
- (5) Disconnect pilot line hoses (3, 4, 5, 6, 7, 9).
- (6) Sling the swing motor assembly (1) and remove the swing motor mounting socket bolts (10).

· Motor device weight : 32 kg (71 lb)

- (7) Remove the swing motor assembly.
※ When removing the swing motor assembly, check that all the piping have been disconnected.

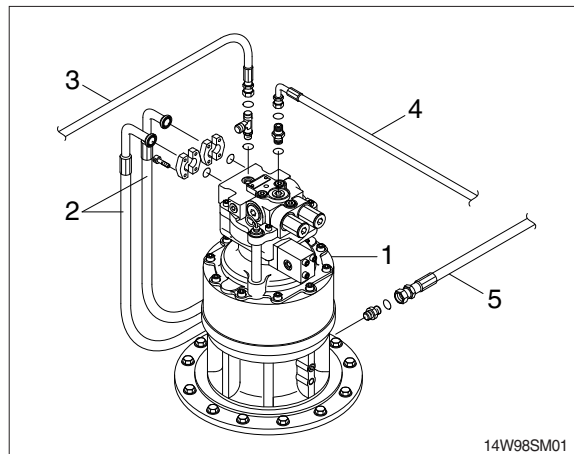

2) INSTALL

- (1) Carry out installation in the reverse order to removal.
- (2) Bleed the air from the swing motor.
 - ① Remove the air vent plug.
 - ② Pour in hydraulic oil until it overflows from the port.
 - ③ Tighten plug lightly.
 - ④ Start the engine, run at low idling and check oil come out from plug.
 - ⑤ Tighten plug fully.
- (3) Confirm the hydraulic oil level and check the hydraulic oil leak or not.

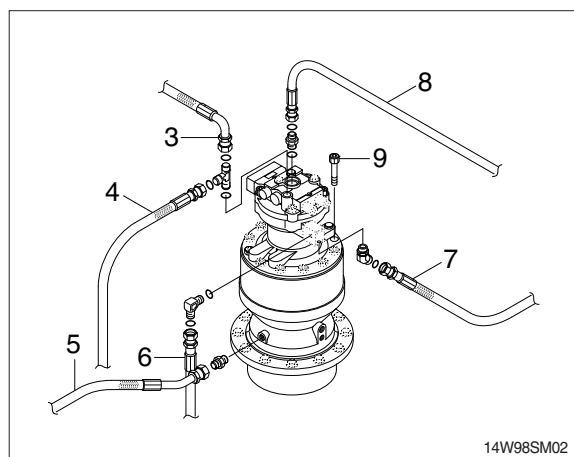

2. DISASSEMBLY AND ASSEMBLY OF SWING MOTOR

1) STRUCTURE

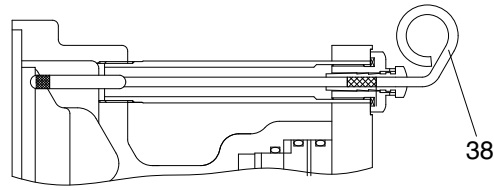

DETAIL K

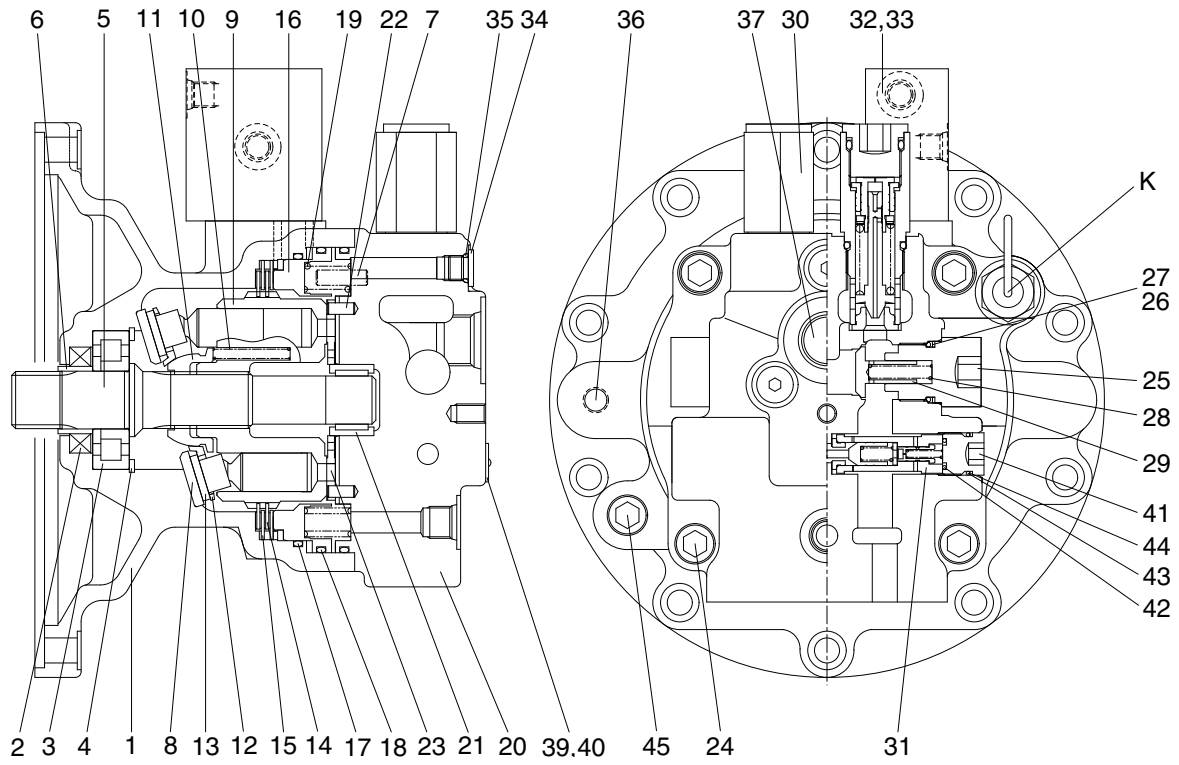

140W9A2SM02

1	Body	16	Brake piston	31	Anti-rotating valve assy
2	Oil seal	17	O-ring	32	Time delay valve assy
3	Roller bearing	18	O-ring	33	Wrench bolt
4	Snap ring	19	Brake spring	34	Plug
5	Drive shaft	20	Rear cover	35	O-ring
6	Bushing	21	Needle bearing	36	Plug
7	Pin	22	Pin	37	Plug
8	Shoe plate	23	Valve plate	38	Level gauge
9	Cylinder block	24	Wrench bolt	40	Rivet
10	Spring	25	Plug	41	Plug
11	Ball guide	26	Back up ring	42	O-ring
12	Set plate	27	O-ring	43	O-ring
13	Piston assy	28	Spring	44	Back up ring
14	Friction plate	29	Check	45	Plug
15	Separate plate	30	Relief valve assy		

2) DISASSEMBLY

- (1) Lift the motor out. Clean the motor in kerosene and dry with compressed air.
 - ※ To avoid dust inside the motor, mask all the ports of the motor with tapes.

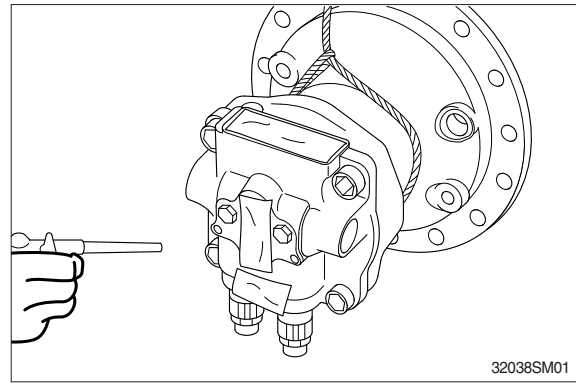

- (2) Loosen the drain plug to discharge oil in the body(1).

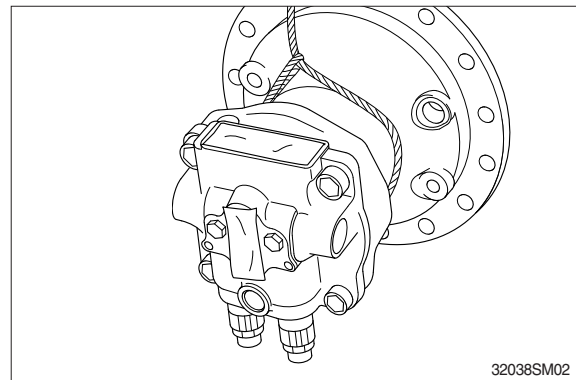

- (3) Fix the drive shaft (5) on the workbench with the end of output shaft down. Put matching marks on body (1) and valve rear cover (20) for easy reassembly.

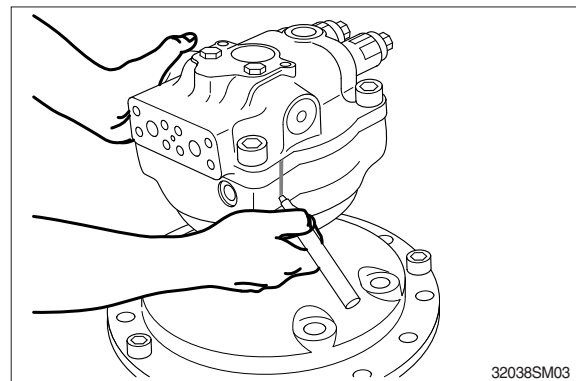

- (4) Remove the valve (32).

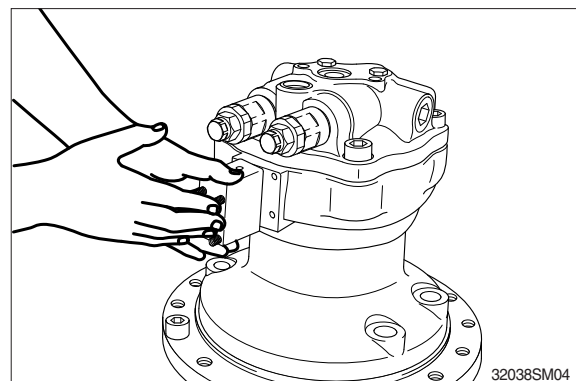

- (5) Remove the relief valve (30) from rear cover (20).

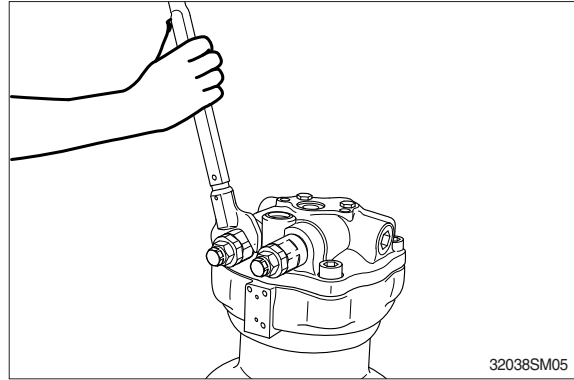

- (6) Remove plug (25) from rear cover (20) and spring (28), check (29).
※ Be careful not to damage the check seat assembly.

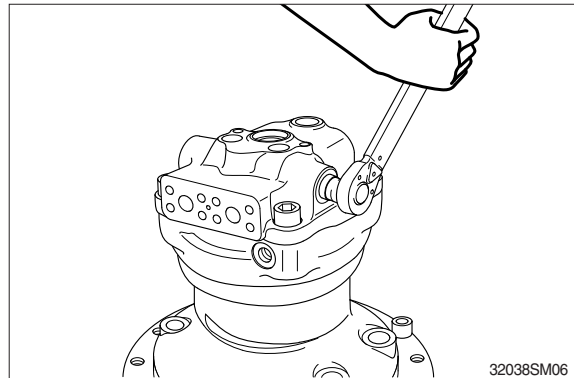

- (7) Remove rear cover (20) from body (1).
Then, remove the valve plate (23) from rear cover (20) with care.

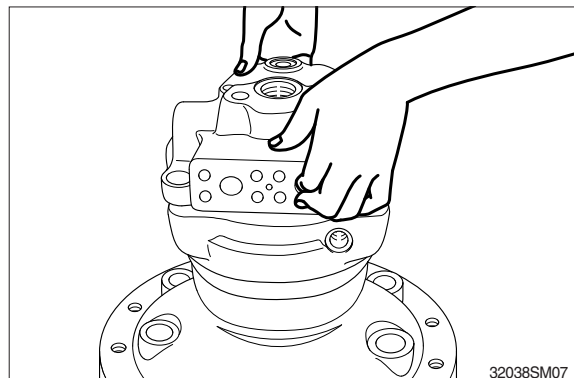

- (8) Remove the brake spring (19) from brake piston (16).

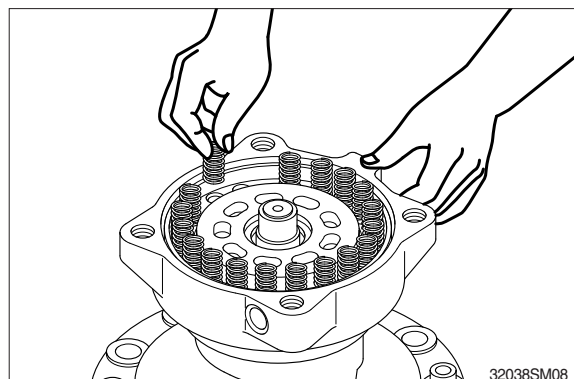

(9) Remove brake piston (16) from body (1).

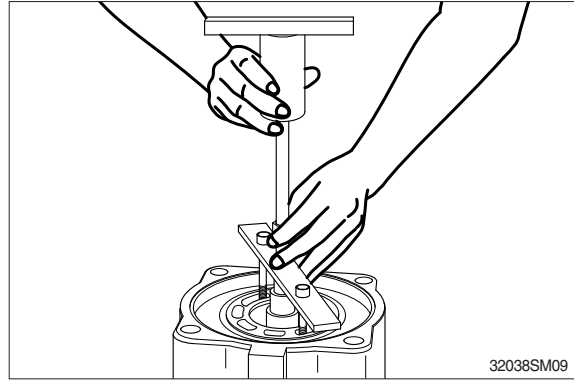

(10) Remove the cylinder (9) from the drive shaft (5) with the motor positioned horizontally. Remove ball guide (11), set plate (12), piston (13) and shoe plate (8).

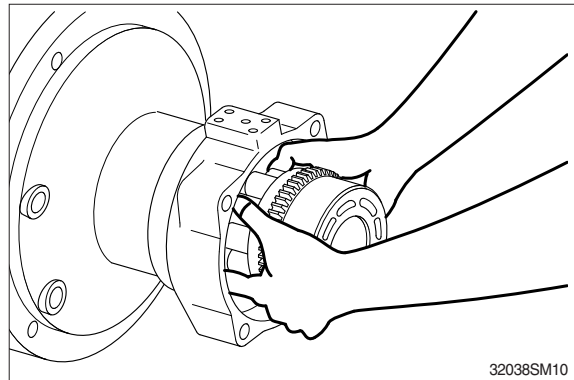

(11) Remove friction plate (14) and separate plate (15) from body (1).

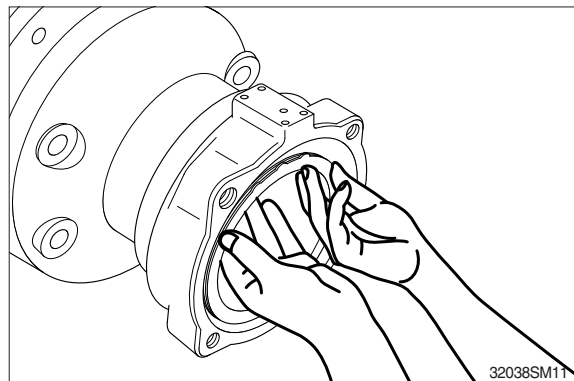

(12) Remove snap ring (4) and remove drive shaft (5) from body (1).

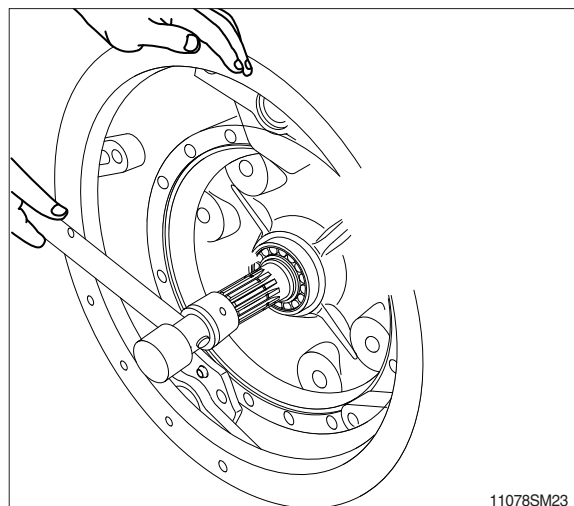

(13) Remove the cone of roller bearing (3) by press.

※ Do not reuse bearings.

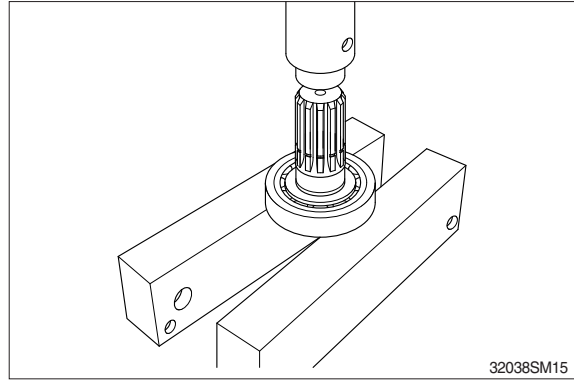
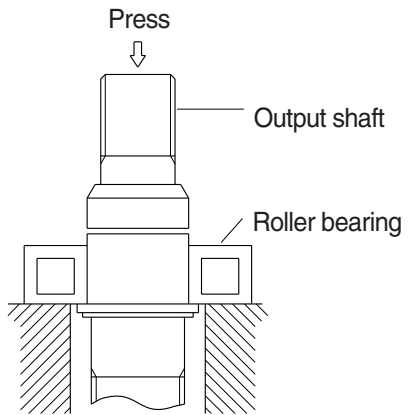

(14) Remove bushing (6) and oil seal (2) from body (1).

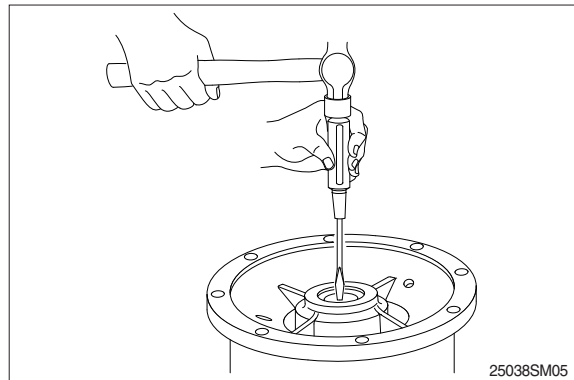

(15) Remove the needle bearing (21) from the rear cover (20) by using slide hammer bearing puller.

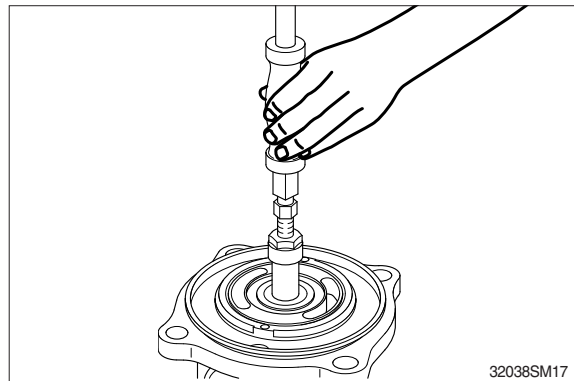

(16) When disassembling the relief valve, release the adjusting screw (5).
Remove the piston (6), spring seat (8), spring (4) and plunger (3) with the body (1) downwards.

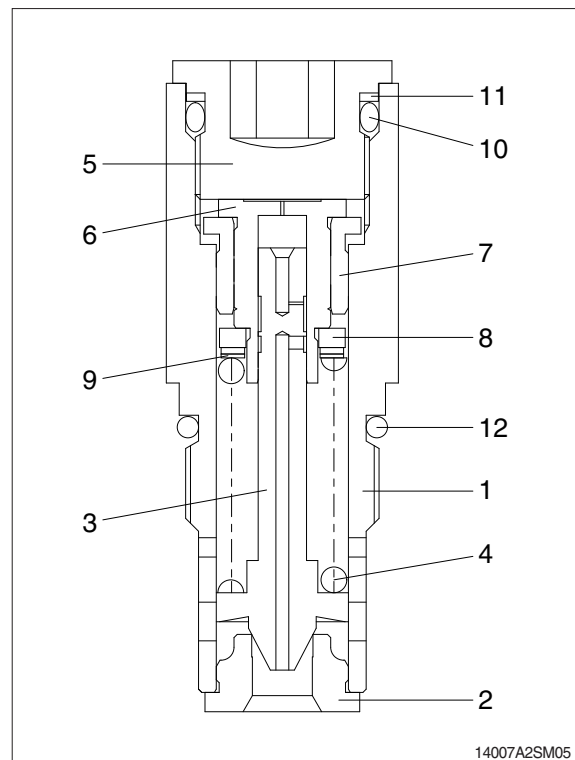

This completes disassembly.

3) ASSEMBLY

Do the reassembly in the reverse procedure of the disassembly.

- (1) Apply three bond of white color on outer surface of oil seal (2) and insert it to the body (1).

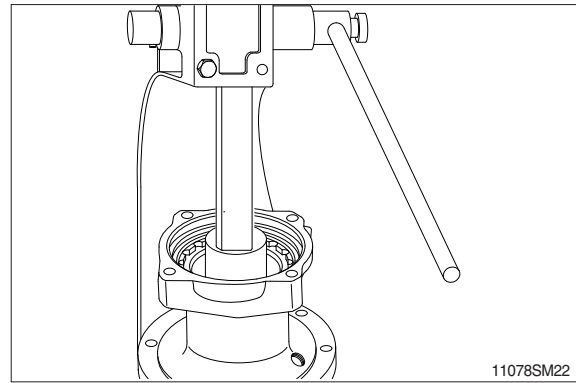

- (2) Install the roller bearing (3) to the drive shaft (5).

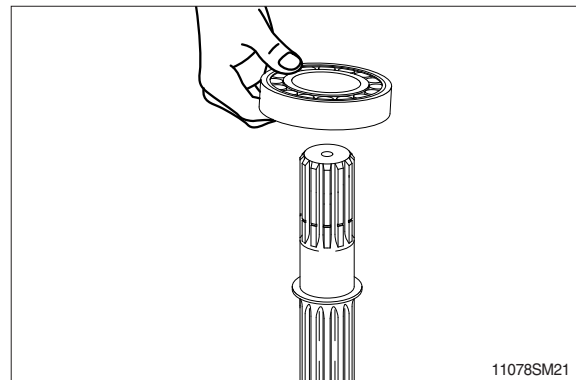

- (3) Insert the drive shaft (5) into the body (1) with the plastic hammer lightly.

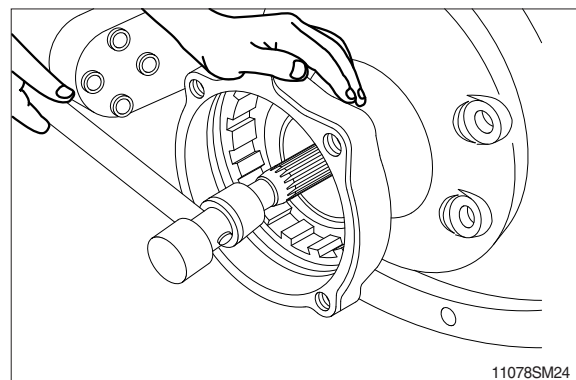

- (4) Install the snap ring (4) to the body (1).

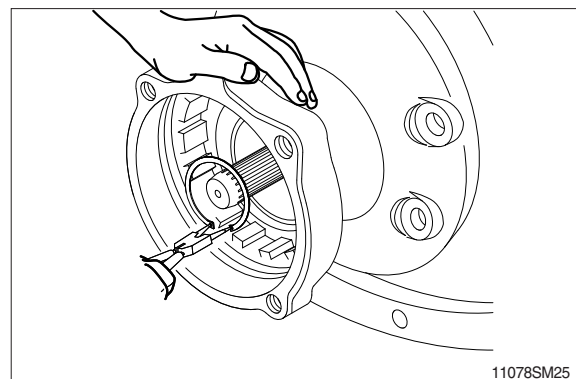

- (5) Insert the shoe plate (8) with the body (1) position horizontally.

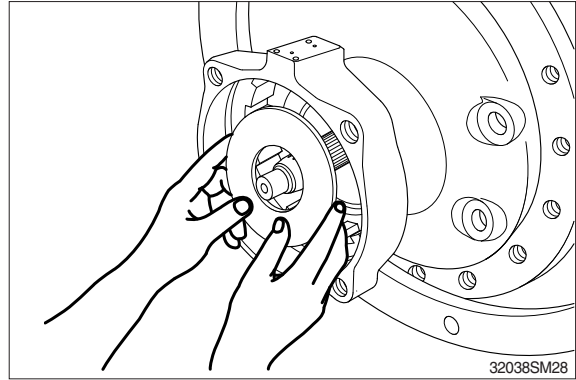

- (6) Insert the ball guide (11) into the cylinder (9).

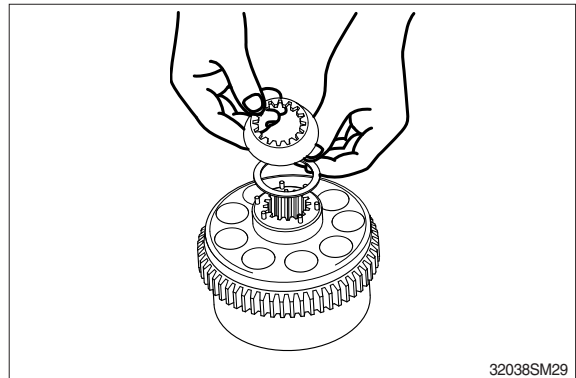

- (7) Install the piston sub-assembly (13) to the set plate (12).

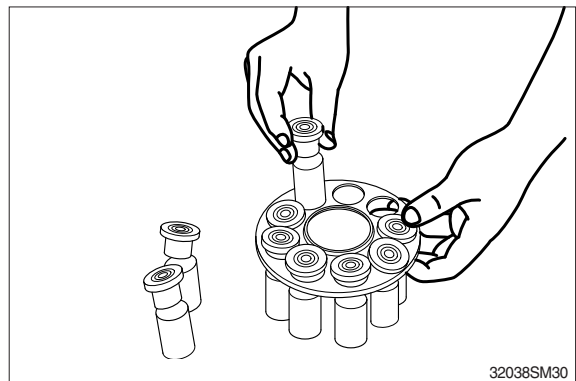

- (8) Reassemble the piston assembly (9) to the body (1).

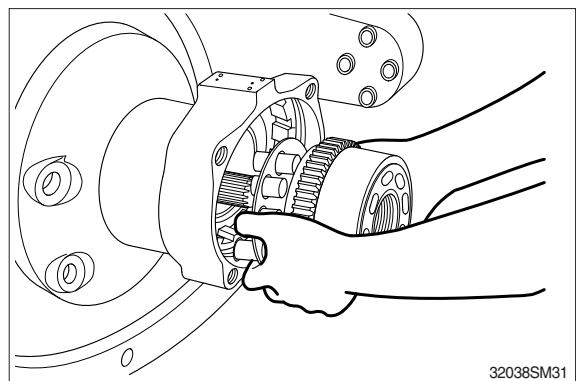

(9) Assembly friction plate (14) and separate plate (15) to the body (1).

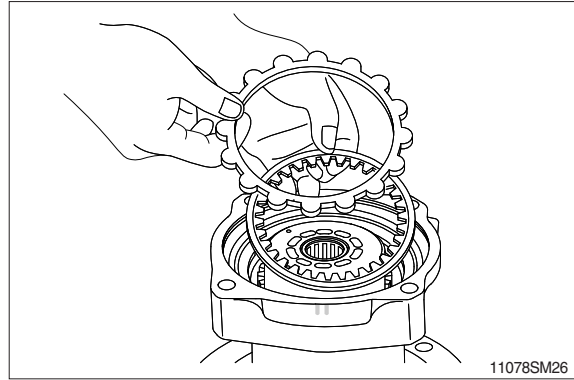

(10) Insert O-ring (17) inside the body (1).

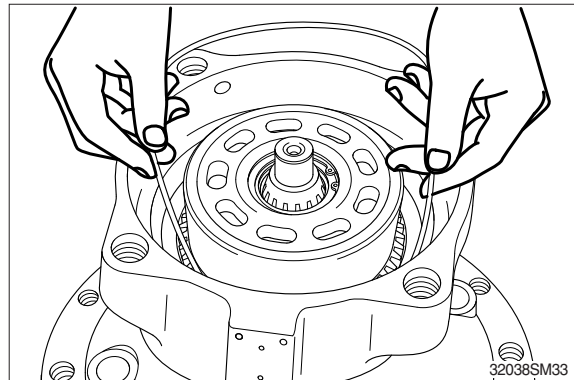

(11) Reassemble brake piston (16) to the body (1).

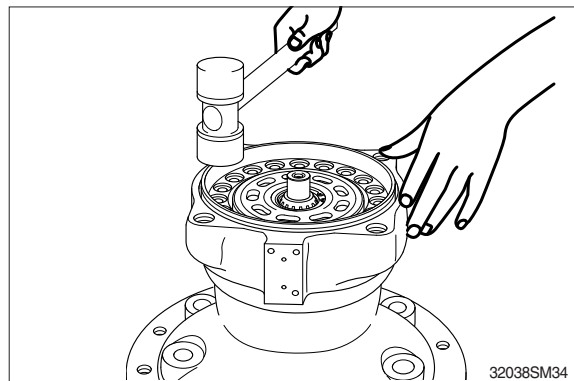

(12) Reassemble brake spring (19) to the brake piston (16).

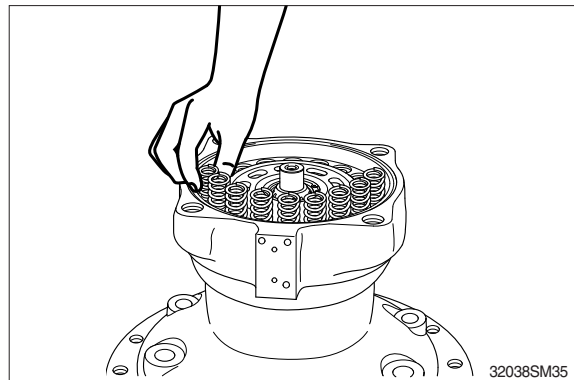

(13) When assembling the needle bearing (21), insert the needle bearing (21) into rear cover (20) by hammering.

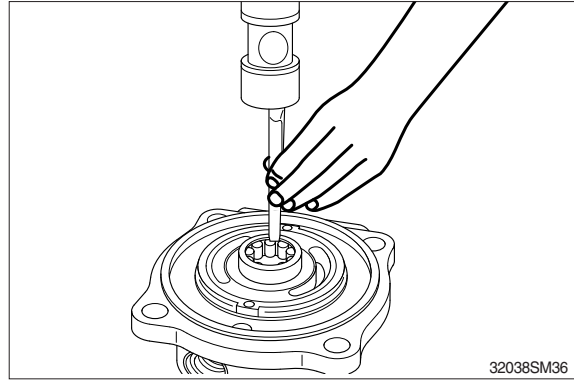

(14) Reassemble valve plate (23) to the rear cover (20) and reassemble O-ring (18).

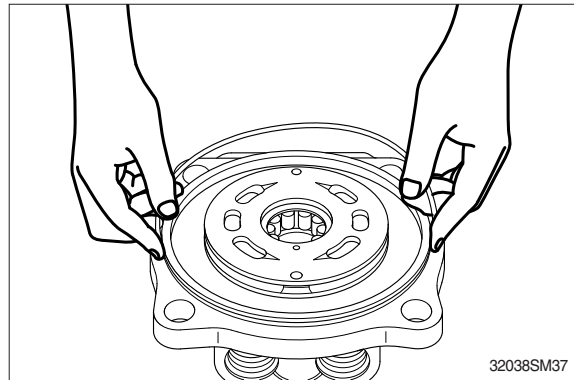

(15) Connect the rear cover (20) with the body (1) and tighten the wrench bolt (24).

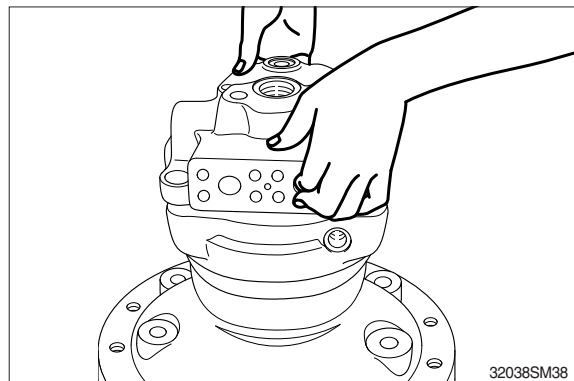

(16) Insert check (29) and spring (28) in the valve casing and install O-ring (27) and back up ring (26). Tighten plug (25) to the rear cover (20).

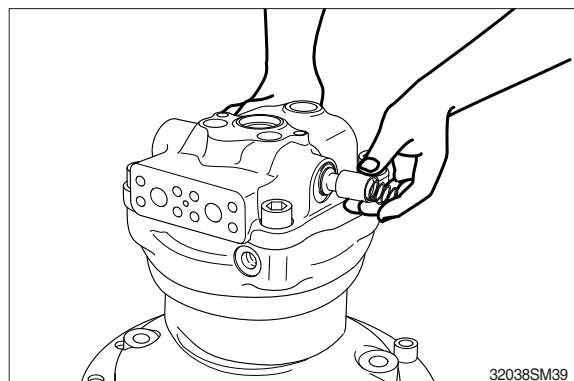

(17) Insert O-rings to the relief valve (30) and reassemble them to rear cover (20).

This completes assembly.

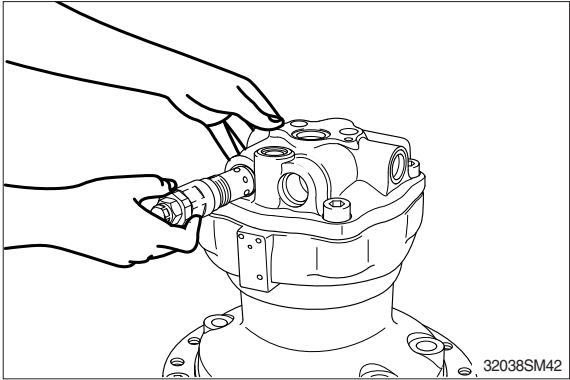

3. REMOVAL AND INSTALL OF REDUCTION GEAR

1) REMOVAL

- (1) Remove the swing motor assembly.
For details, see removal of swing motor assembly.
- (2) Sling reduction gear assembly (1) and remove mounting bolts (2).
- (3) Remove the reduction gear assembly.
 - Reduction gear device weight : 60 kg
(132 lb)



2) INSTALL

- (1) Carry out installation in the reverse order to removal.
 - Tightening torque : 29.6 ± 3.2 kgf · m
(214 ± 23.1 lbf · ft)

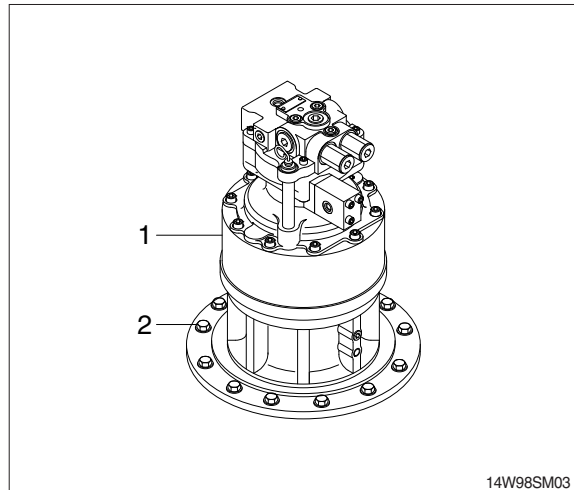

4. DISASSEMBLY AND ASSEMBLY OF REDUCTION GEAR

1) STRUCTURE

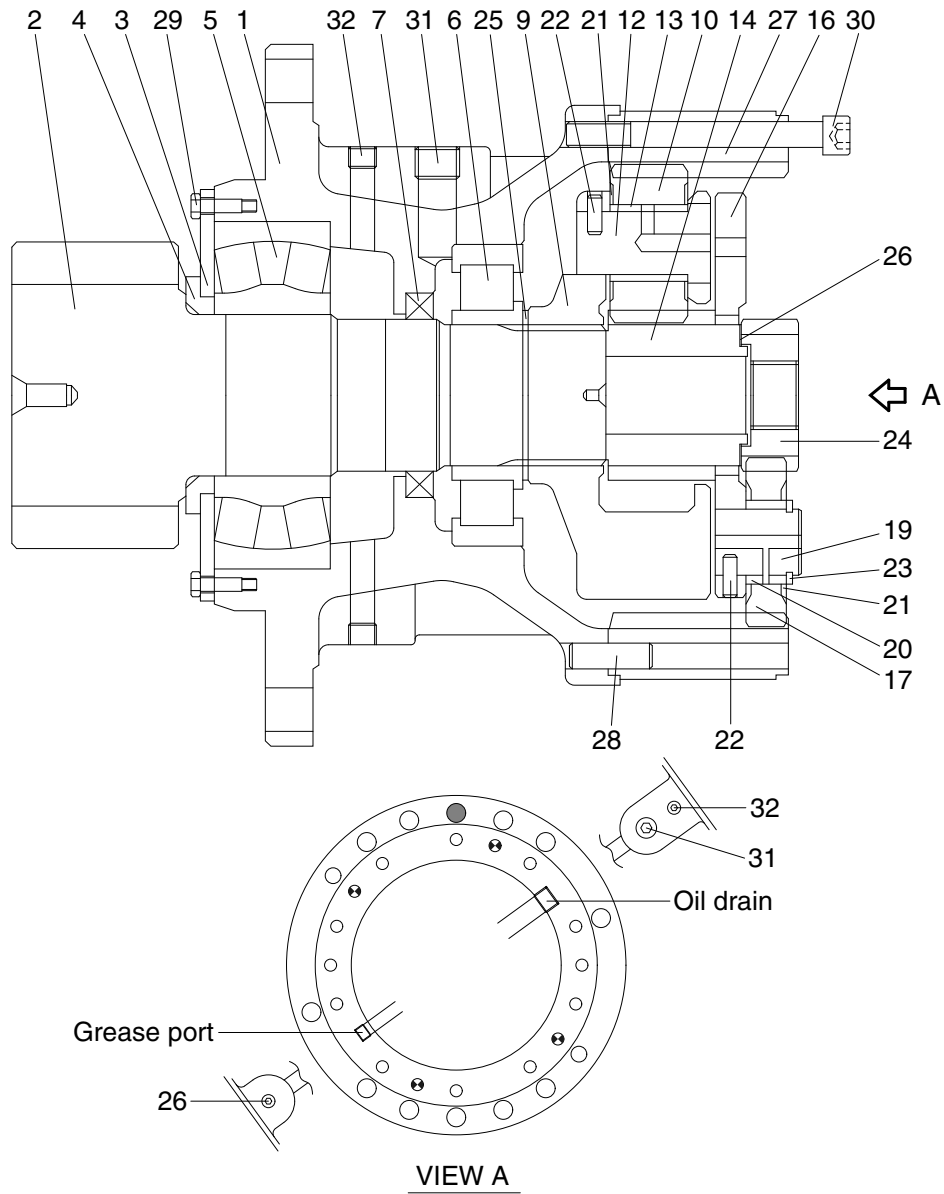

1	Casing	13	Bushing 2	25	Stop ring
2	Drive shaft	14	Sun gear 2	26	Side plate 1
3	Cover plate	16	Carrier 1	27	Ring gear
4	Spacer	17	Planet gear 1	28	Knock pin
5	Roller bearing	19	Pin 1	29	Hexagonal bolt
6	Roller bearing	20	Bushing 1	30	Socket head bolt
7	Oil seal	21	Thrust washer	31	Plug
9	Carrier 2	22	Spring pin	32	Plug
10	Planet gear 2	23	Stop ring		
12	Pin 2	24	Sun gear 1		

140W9A2SM03

2) DISASSEMBLY

- (1) Remove level gauge (38) from the swing motor casing.
※ Pour the gear oil out of reduction gear into the clean bowl to check out the friction decrease.

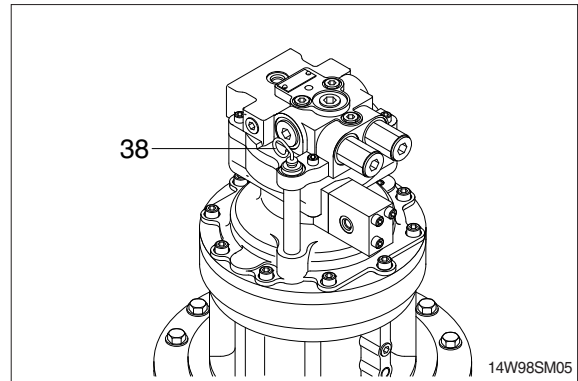

- (2) Loosen the socket bolts (30) to separate swing motor from reduction gear.

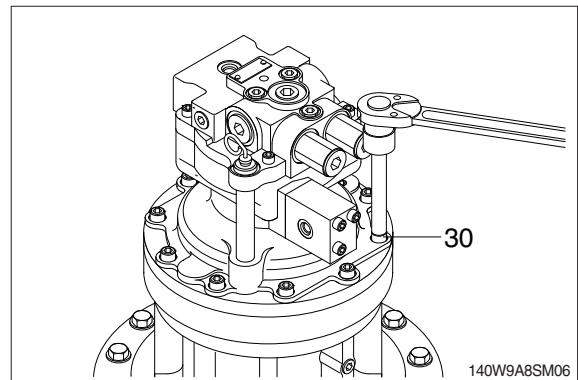

- (3) Remove sun gear 1 (24).

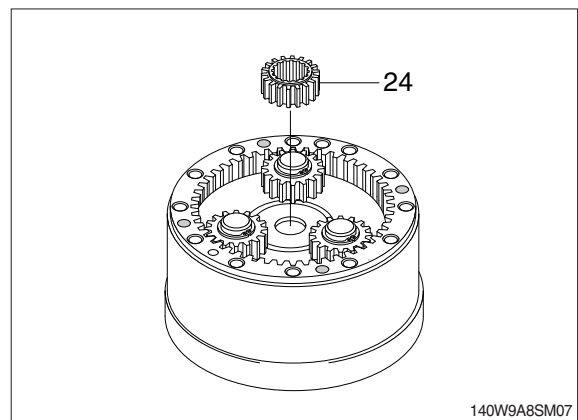

- (4) Tighten two M10 eye bolts to carrier 1 (16) and lift up and remove carrier 1 (16) as subassembly.

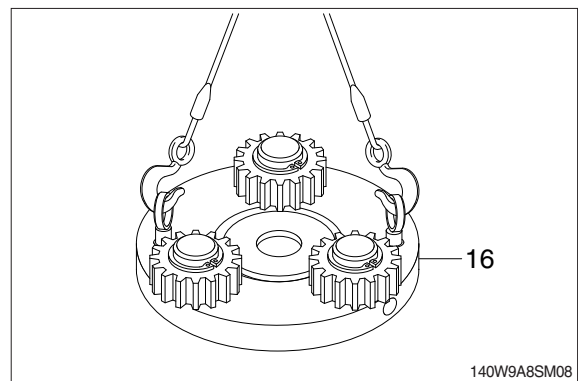

(5) Disassembling carrier 1 (16) assembly.

- ① Remove stop ring (23).
 - ② Remove thrust washer (21) and planet gear 1 (17) from the carrier 1 (16).
 - ③ Using M8 solid drill, crush spring pin (22) so that the pin 1 (19) can be removed by hammering.
- * Do not reuse spring pin (22).
 - * Do not remove pin 1 (19), carrier 1 (16) and spring pin (22) but in case of replacement.
 - * Put matching marks on the planet gear 1 (17) and the pin 1 (19) for easy reassembly.

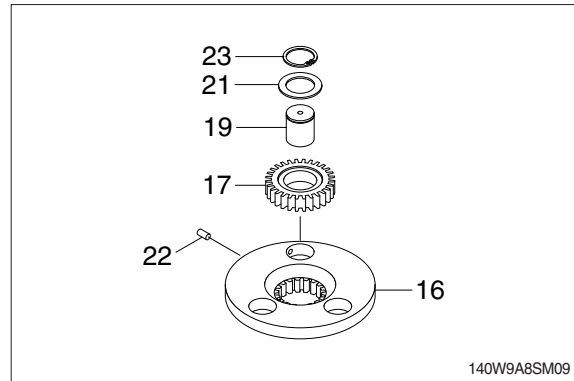

(6) Remove sun gear 2 (14) and side plate 1 (26) from carrier 2 (9).

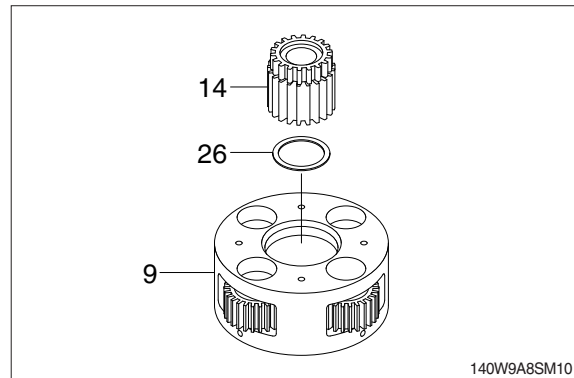

(7) Remove carrier 2 (9) assembly from casing (1).

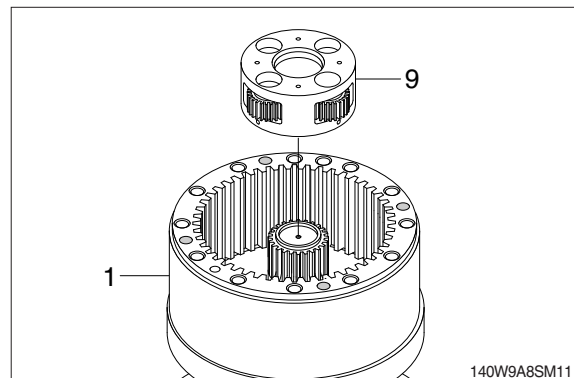

(8) Disassembling carrier 2 (9) assembly.

① Using M8 solid drill, crush spring pin (22) so that the pin 2 (12) can be removed.

※ Do not reuse spring pin (22).

② Remove pin 2 (12) and planet gear 2 (10) from the carrier 2 (9).

※ Put matching marks on the planet gear 2 (10) and the pin 2 (22) for easy reassembly.

※ Do not disassemble pin 2 (12), carrier 2 (9) and spring pin (22) but in case of replacement.

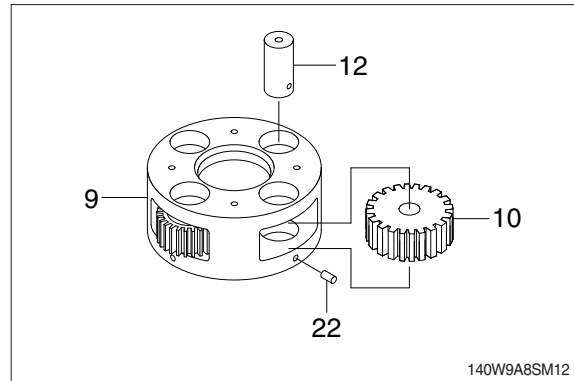

(9) Tighten two M16 eyebolt to the ring gear (27) and then lift the ring gear (27) out of casing (1).

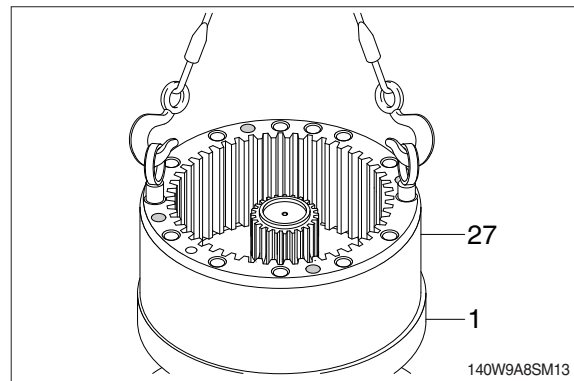

(10) Remove stop ring (25) from the drive shaft (2).

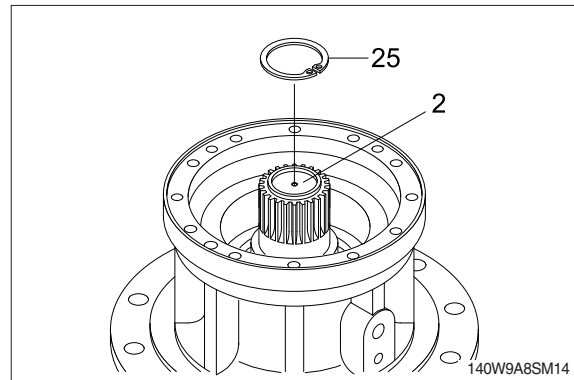

(11) Remove drive shaft (2) with roller bearing (6) and oil seal (7) assembled. Remove knock pin (28) from the casing (1).

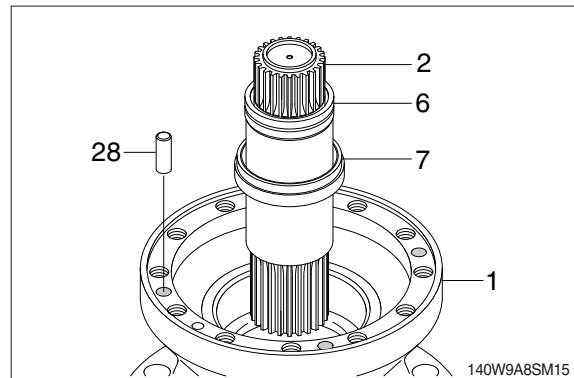

- (12) Remove roller bearing (6) and oil seal (7) from the drive shaft (2).
※ Do not reuse oil seal (7) once removed.

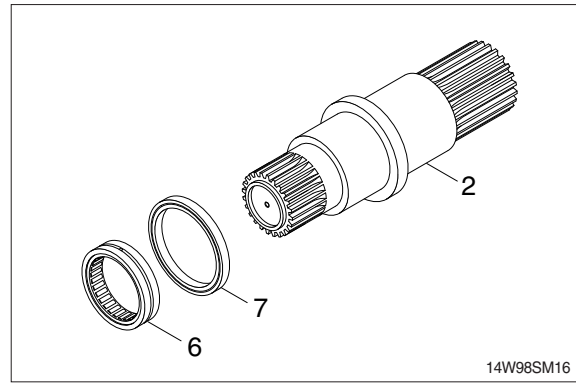

- (13) Using the bearing disassembly tool, remove roller bearing (5).

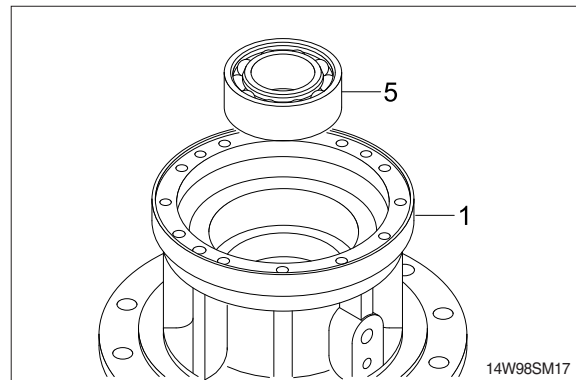

- (14) Remove plugs (31, 32) from the casing (1).

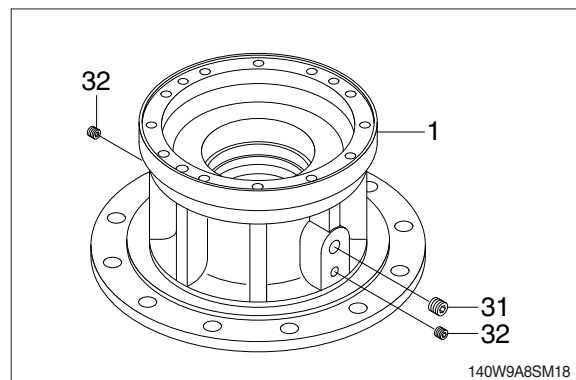

3) ASSEMBLY

- (1) Assemble roller bearing (5) inside the casing (1).

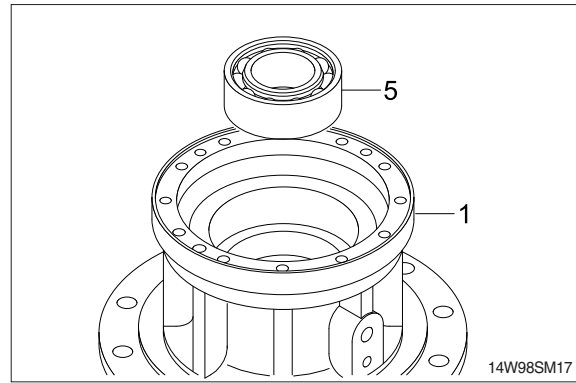

- (2) Assemble the drive shaft (2) into the casing (1) and then install oil seal (7) and roller bearing (6).

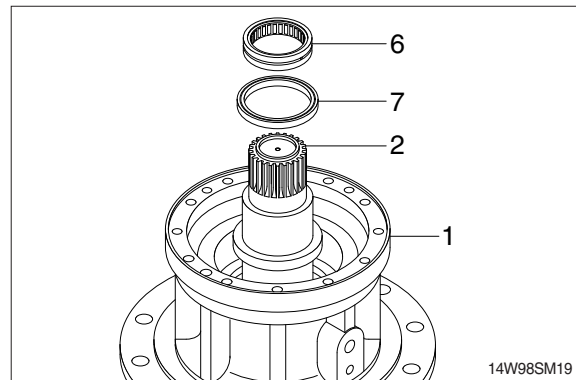

- (3) Install stop ring (25) on top of drive shaft (2).

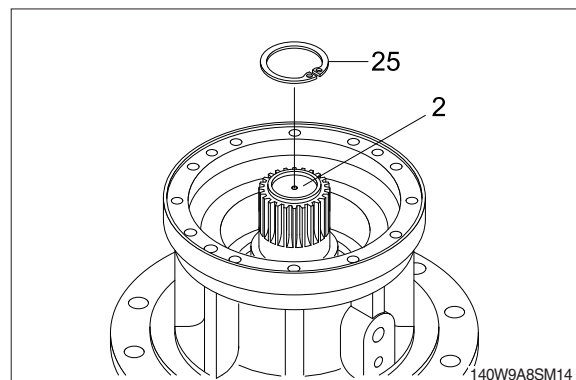

- (4) Apply loctite to the tapped holes of casing (1).

- (5) Tighten 2 M16 eye bolts to the ring gear (27) and lift up and then assemble it onto the casing (1).

※ Don't fail to coincide the knock pin (28) holes.

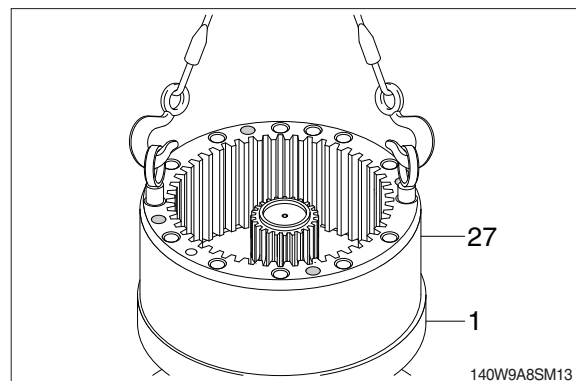

(6) Assembling carrier 2 (9) assembly.

- ① Install the planet gear 2 (10) inside the carrier 2 (9).
 - ② Assemble the pin 2 (12) to the carrier 2 (9) and then press the spring pin (22) by hammering.
 - ③ Punch 2 points of the spring pin (22) lip.
- ※ Take care not to mistake the matching marks of each part.

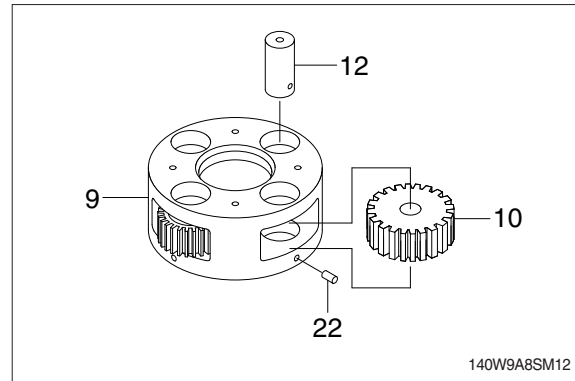

(7) Assemble carrier 2 (9) assembly correctly to the casing (1).

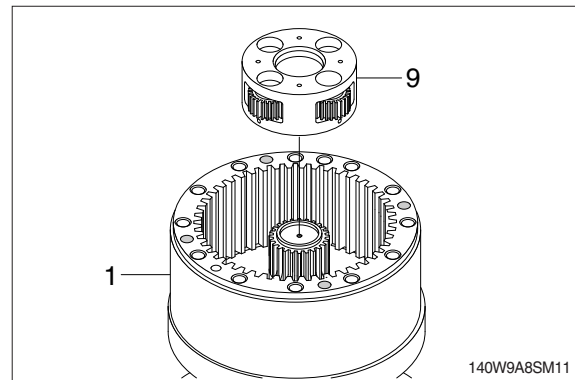

(8) Assemble sun gear 2 (14) and side plate 1 (26) to the center of the carrier 2 (9) assembly.

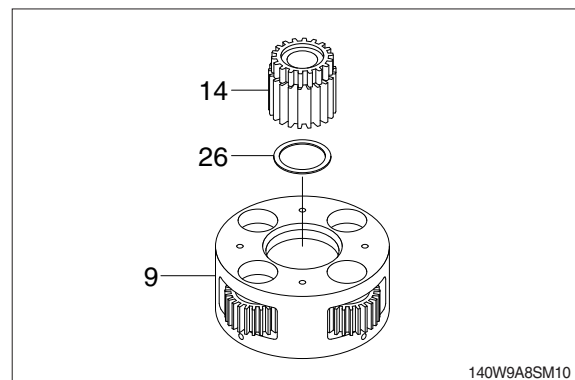

(9) Assembling carrier 1 (16) assembly.

- ① Assemble the pin1 (19) to the carrier 1 (16) and then press the spring pin (22) by hammering.
 - ② Punch 2 points of the spring pin's (22) lip.
 - ③ Assemble thrust washer (21), planet gear 1 (17), and then stop ring (23) to the pin 1 (14).
- ※ Take care not to mistake the matching marks of each part.

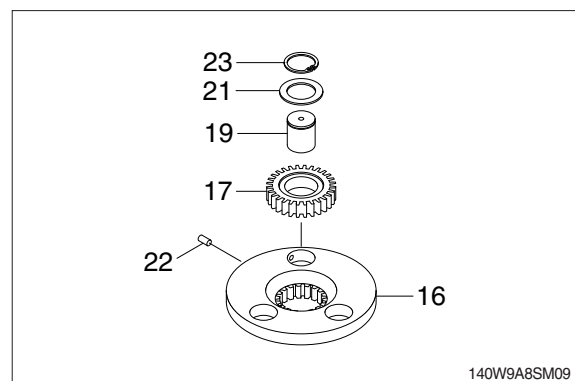

(10) Assemble carrier 1 (16) assembly into the ring gear (27).

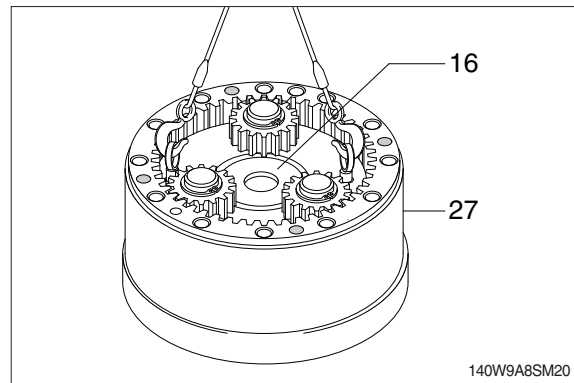

(11) Hammer 4 knock pins (28) around the ring gear (27).

(12) Assemble sun gear 1 (24) to the drive shaft of the swing reduction gear.

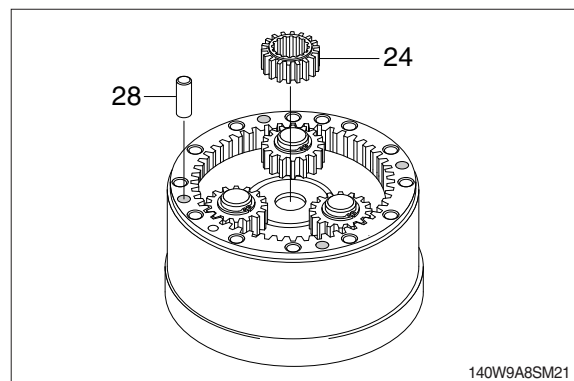

(13) Apply loctite to the tapped holes of the ring gear (27) and then mount swing motor onto the ring gear (27).

※ Don't fail to coincide the gauge bar hole.

(14) Tighten socket bolts (30) around the swing motor assembly.
· Tightening torque : 13.5 kgf · m (98 lbf · ft)

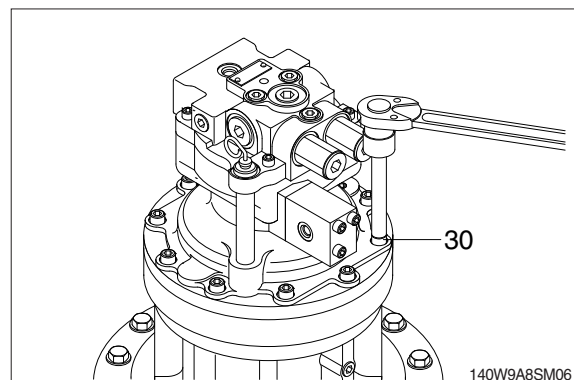

(15) Assemble plugs (31, 32) and level gauge (38).

