

# GROUP 6 STRUCTURE

## 1. CAB AND ACCESSORIES MOUNTING

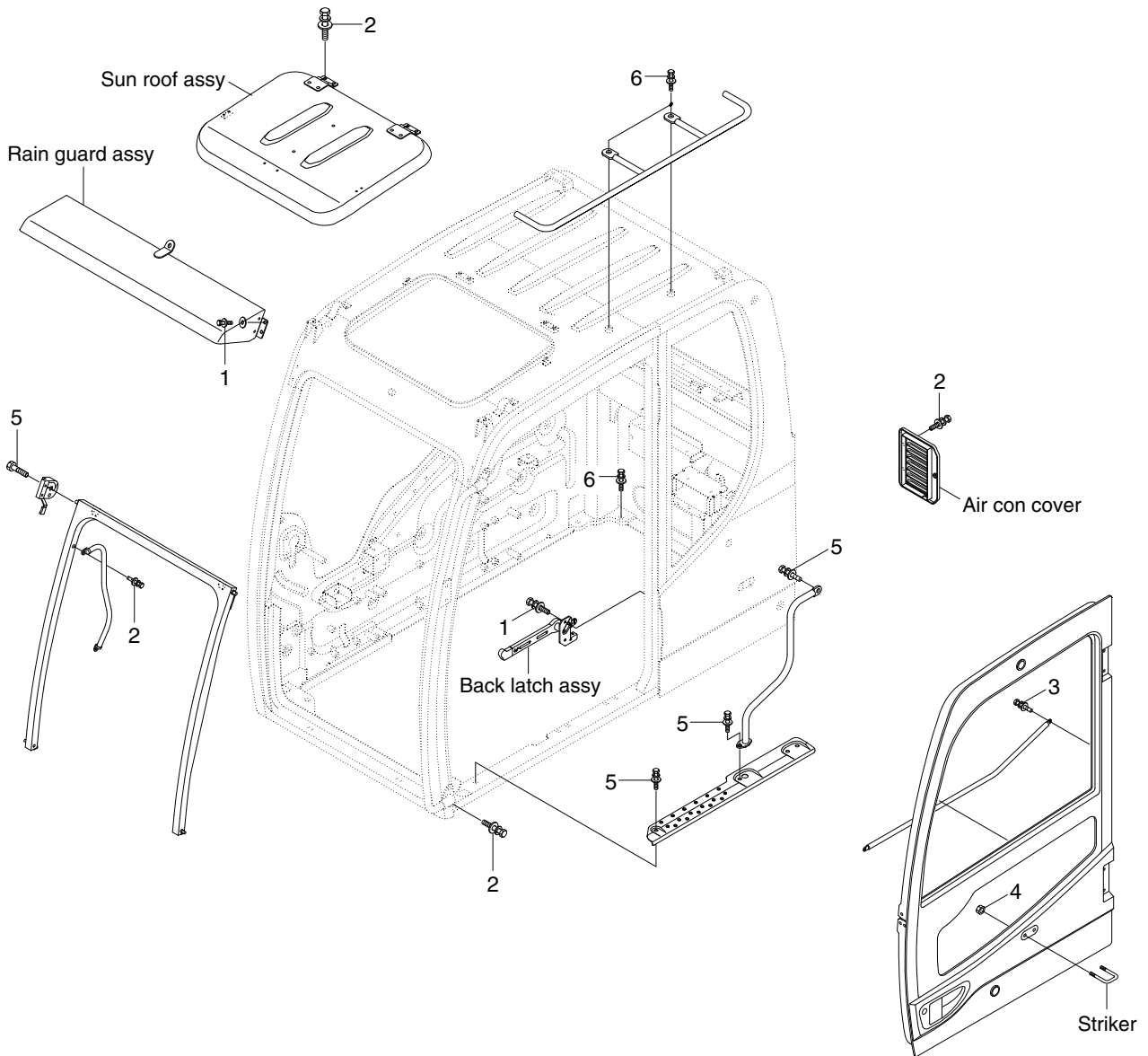

RB1409S9CM09

### · Tightening torque

Item	Size	kgf · m	lbf · ft
1	M 6×1.0	1.05±0.2	7.6±1.45
2	M 8×1.25	2.5±0.5	18.1±3.6
3	M 8×1.25	3.43±0.7	24.8±5.1

Item	Size	kgf · m	lbf · ft
4	M10×1.5	4.7±0.9	34±6.5
5	M10×1.5	6.9±1.4	49.9±10.1
6	M12×1.75	12.8±3.0	92.6±21.7

## 2. CAB INTERIOR MOUNTING

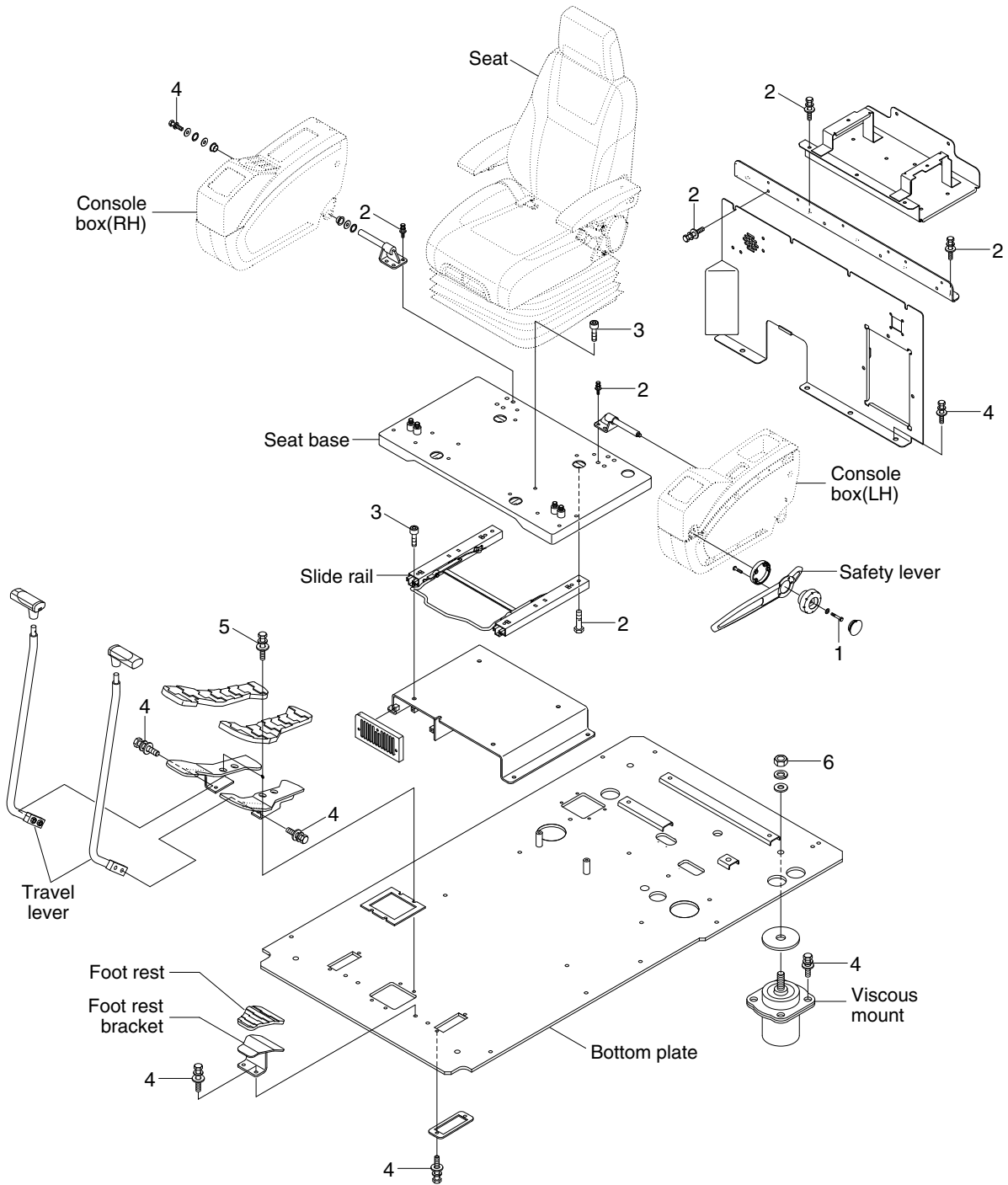

RB1409S9CM10

### • Tightening torque

Item	Size	kgf · m	lbf · ft
1	M 6×1.0	1.05±0.2	7.6±1.45
2	M 8×1.25	2.5±0.5	18.1±3.6
3	M 8×1.25	4.05±0.8	29.3±5.8

Item	Size	kgf · m	lbf · ft
4	M10×1.5	6.9±1.4	49.9±10.1
5	M10×1.5	8.27±1.7	59.8±12.3
6	M16×2.0	29.7±4.5	215±32.5

### 3. COWLING MOUNTING

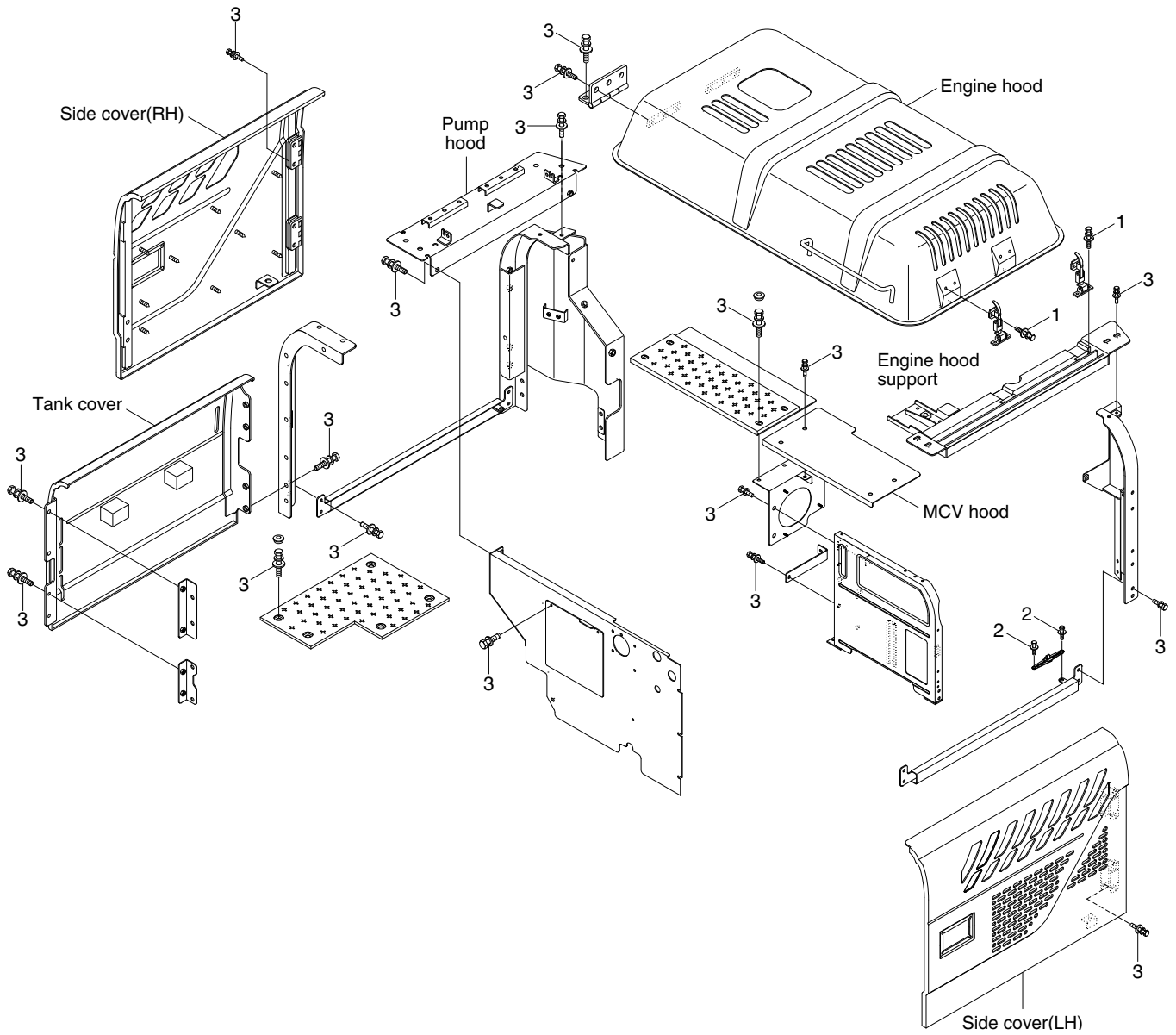

RB1409S9CM11

• Tightening torque

Item	Size	kgf · m	lbf · ft
1	M 8×1.25	2.5±0.5	18.1±3.6
2	M10×1.5	6.9±1.4	49.9±10.1

Item	Size	kgf · m	lbf · ft
3	M12×1.75	12.8±3.0	92.6±21.7
-	-	-	-

## 4. COUNTERWEIGHT AND COVERS MOUNTING

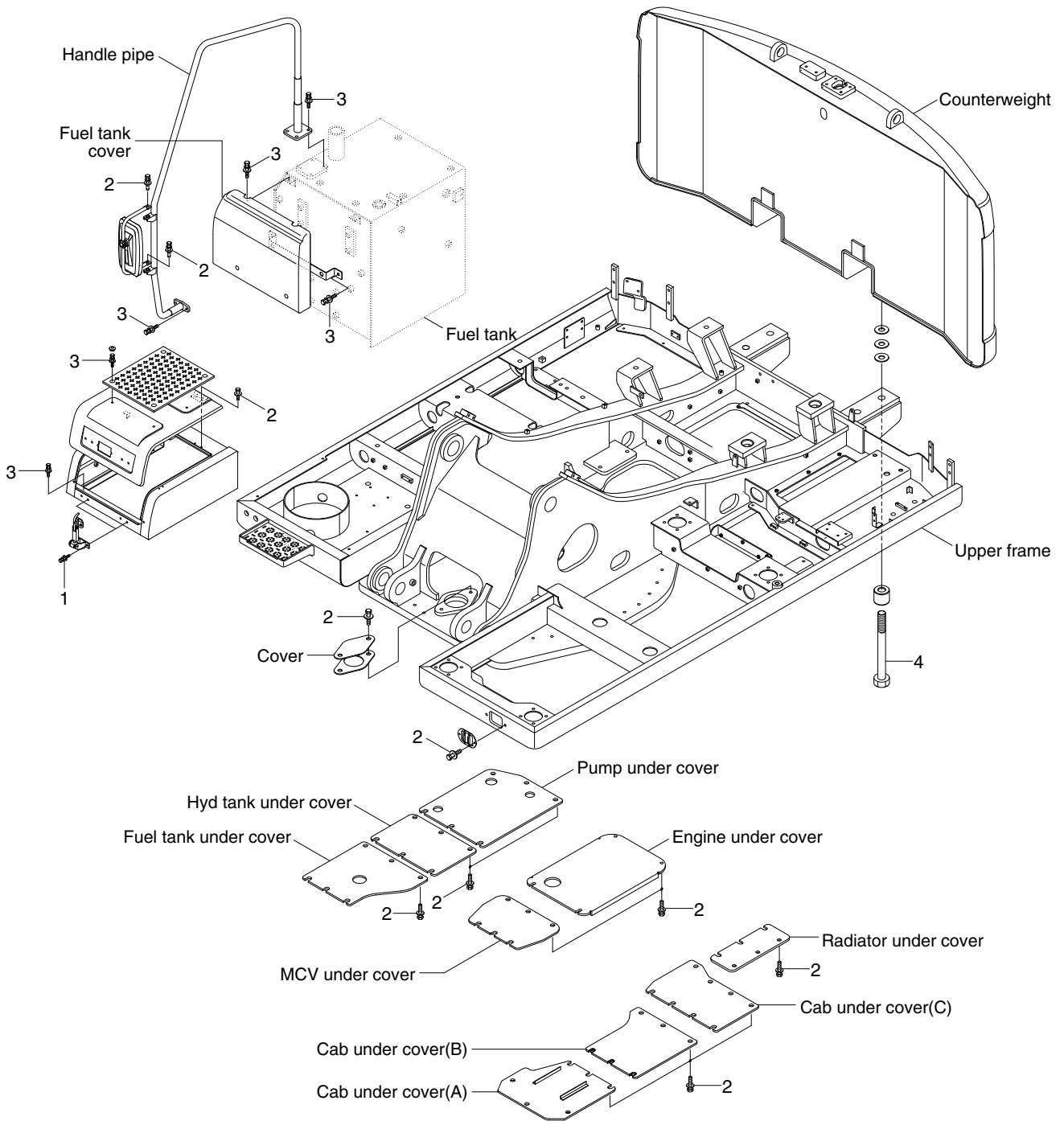

RB1409S9CM12

### · Tightening torque

Item	Size	kgf · m	lbf · ft
1	M 8×1.25	2.5±0.5	18.1±3.6
2	M10×1.5	6.9±1.4	49.9±10.1

Item	Size	kgf · m	lbf · ft
3	M12×1.75	12.8±3.0	92.6±21.7
4	M27×3.0	140±15	1013±108