

SECTION 4 ELECTRICAL SYSTEM

Group 1 Component Location	4-1
Group 2 Electrical Circuit	4-3
Group 3 Electrical Component Specification	4-21
Group 4 Connectors	4-29

SECTION 4 ELECTRICAL SYSTEM

GROUP 1 COMPONENT LOCATION

1. LOCATION 1

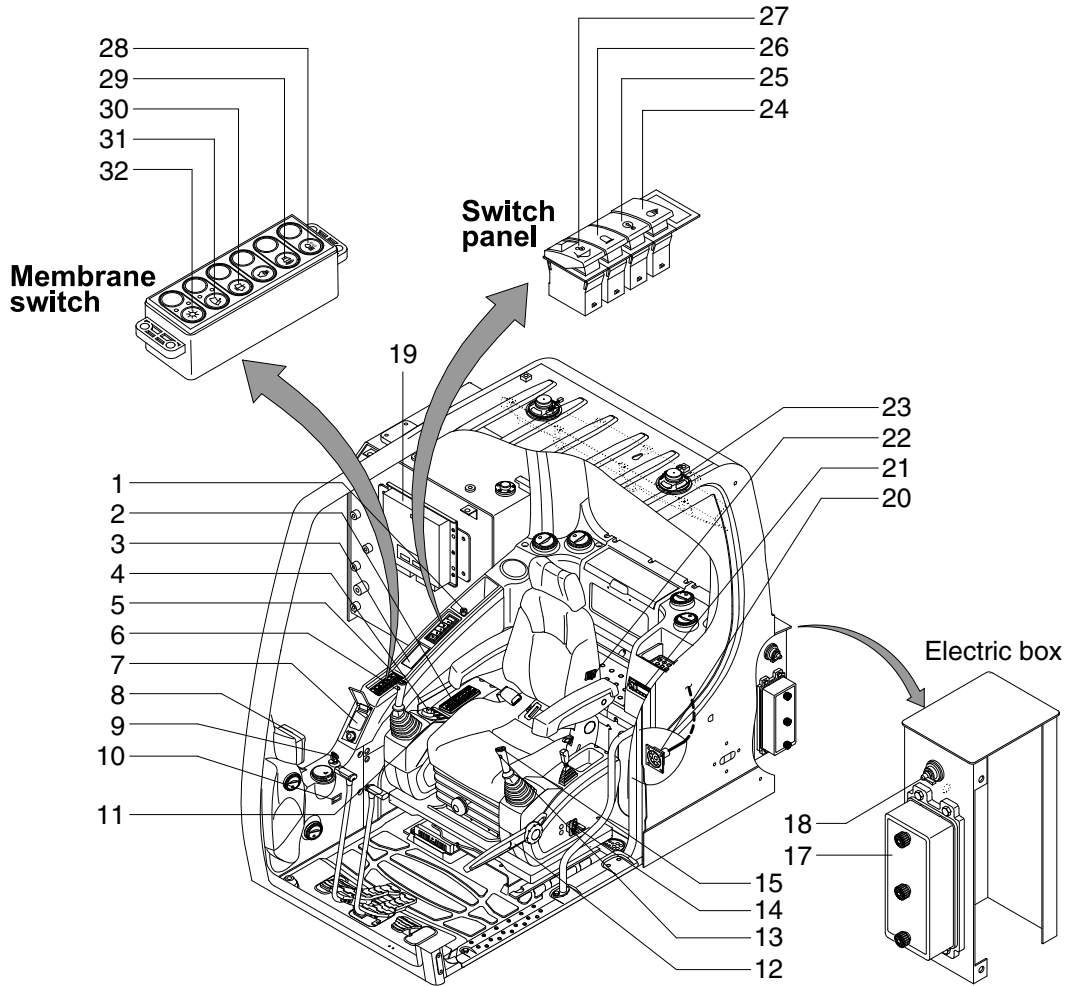

1609SB4EL01

- | | | |
|----------------------------|---------------------------------|--------------------------|
| 1 Cigar lighter | 12 Safety lever | 24 Rear work lamp switch |
| 2 Air conditioner switch | 13 Power max switch | 25 Overload switch |
| 3 Remote controller | 14 Emergency engine stop switch | 26 Beacon switch |
| 4 Accel dial switch | 15 One touch decel switch | 27 Quick clamp switch |
| 5 Horn switch | 17 Fuse & relay box | 28 Cab light switch |
| 6 Breaker operation switch | 18 Master switch | 29 Travel alarm switch |
| 7 Handsfree | 19 Machine control unit | 30 Washer switch |
| 8 Cluster | 20 RS232 & J1939 service socket | 31 Wiper switch |
| 9 Start switch | 21 Radio & USB player | 32 Main light switch |
| 10 Hour meter | 22 Heated seat switch | |
| 11 Air compressor switch | 23 Speaker | |

2. LOCATION 2

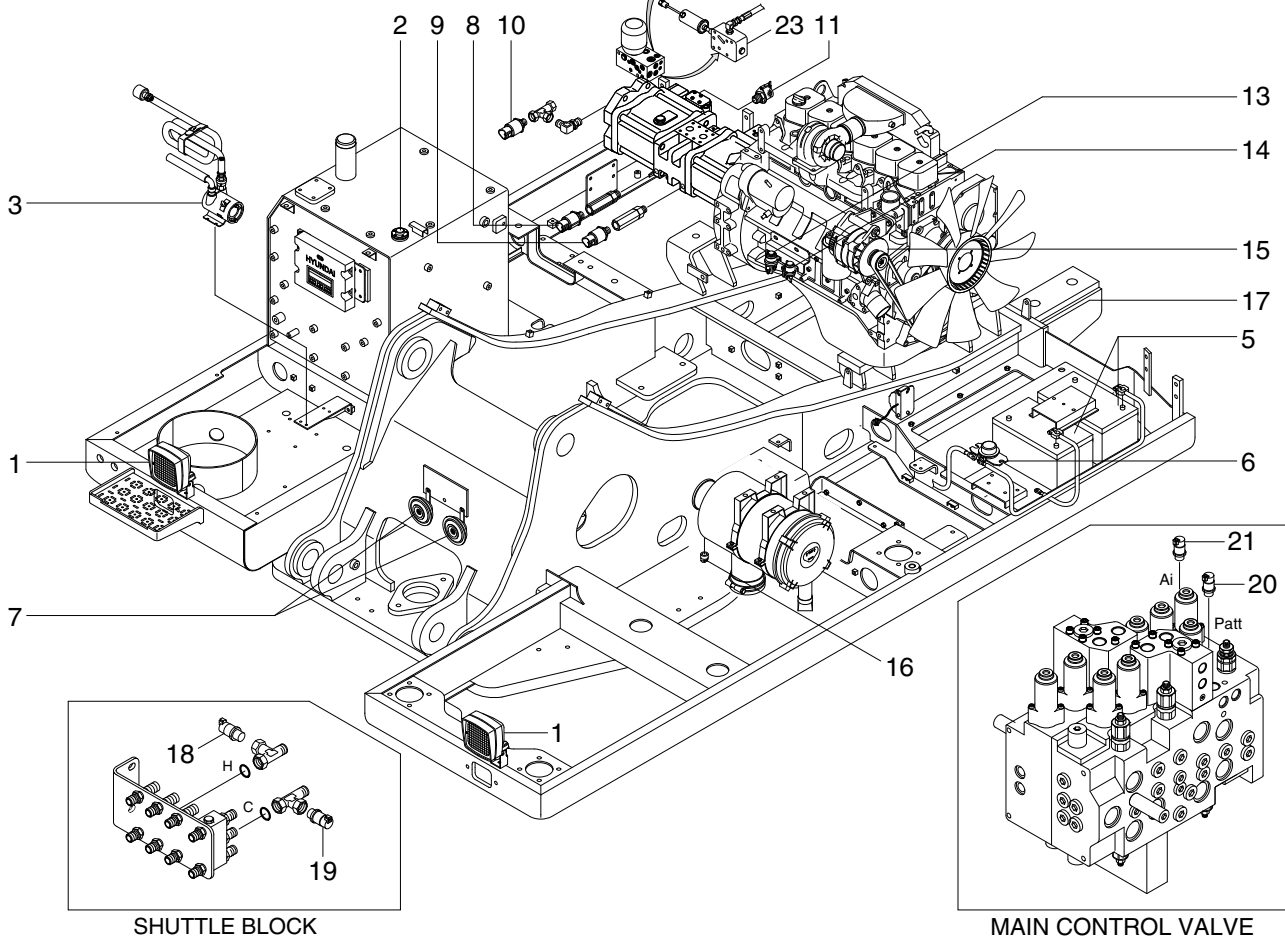
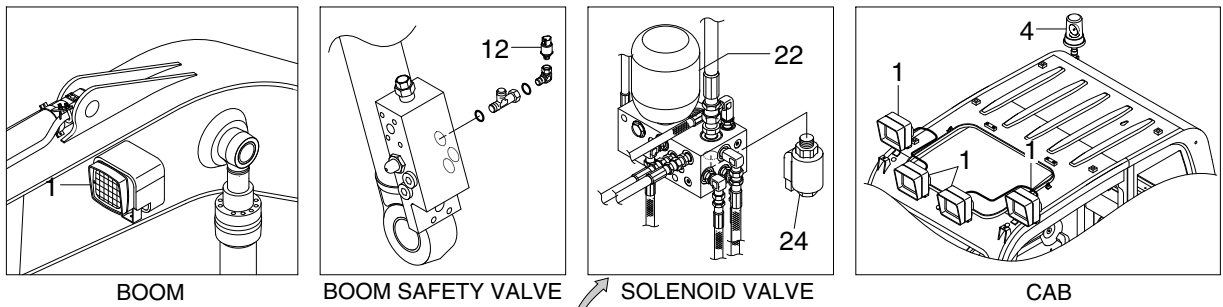

1409SB4EL02

- | | | | | | |
|---|--------------------|----|--------------------------|----|--------------------------|
| 1 | Lamp | 9 | P2 pressure sensor | 17 | Travel alarm |
| 2 | Fuel sender | 10 | P3 pressure sensor | 18 | Boom up pressure sensor |
| 3 | Fuel filler pump | 11 | EPPR screw coupling | 19 | Swing pressure sensor |
| 4 | Beacon lamp | 12 | Overload pressure sensor | 20 | Attach pressure sensor |
| 5 | Battery | 13 | Start relay | 21 | Travel pressure sensor |
| 6 | Battery relay | 14 | Heater relay | 22 | Solenoid valve |
| 7 | Horn | 15 | Alternator | 23 | Pump EPPR valve |
| 8 | P1 pressure sensor | 16 | Air cleaner switch | 24 | Boom priority EPPR valve |