

SECTION 9 COMPONENT MOUNTING TORQUE

Group 1	Introduction guide	9-1
Group 2	Engine system	9-2
Group 3	Electric system	9-4
Group 4	Hydraulic system	9-6
Group 5	Undercarriage	9-9
Group 6	Structure	9-10
Group 7	Work equipment	9-14

SECTION 9 COMPONENT MOUNTING TORQUE

GROUP 1 INTRODUCTION GUIDE

1. This section shows bolt specifications and standard torque values needed when mounting components to the machine.
 2. Use genuine Hyundai spare parts.
We expressly point out that Hyundai will not accept any responsibility for defects resulted from non-genuine parts.
In such cases Hyundai cannot assume liability for any damage.
- ※ Only metric fasteners can be used and incorrect fasteners may result in machine damage or malfunction.
 - ※ Before installation, clean all the components with a non-corrosive cleaner. Bolts and threads must not be worn or damaged.

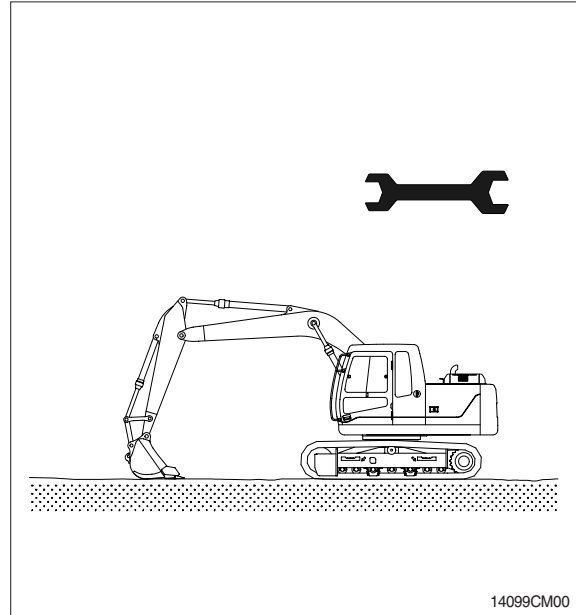

GROUP 2 ENGINE SYSTEM

1. ENGINE AND ACCESSORIES MOUNTING

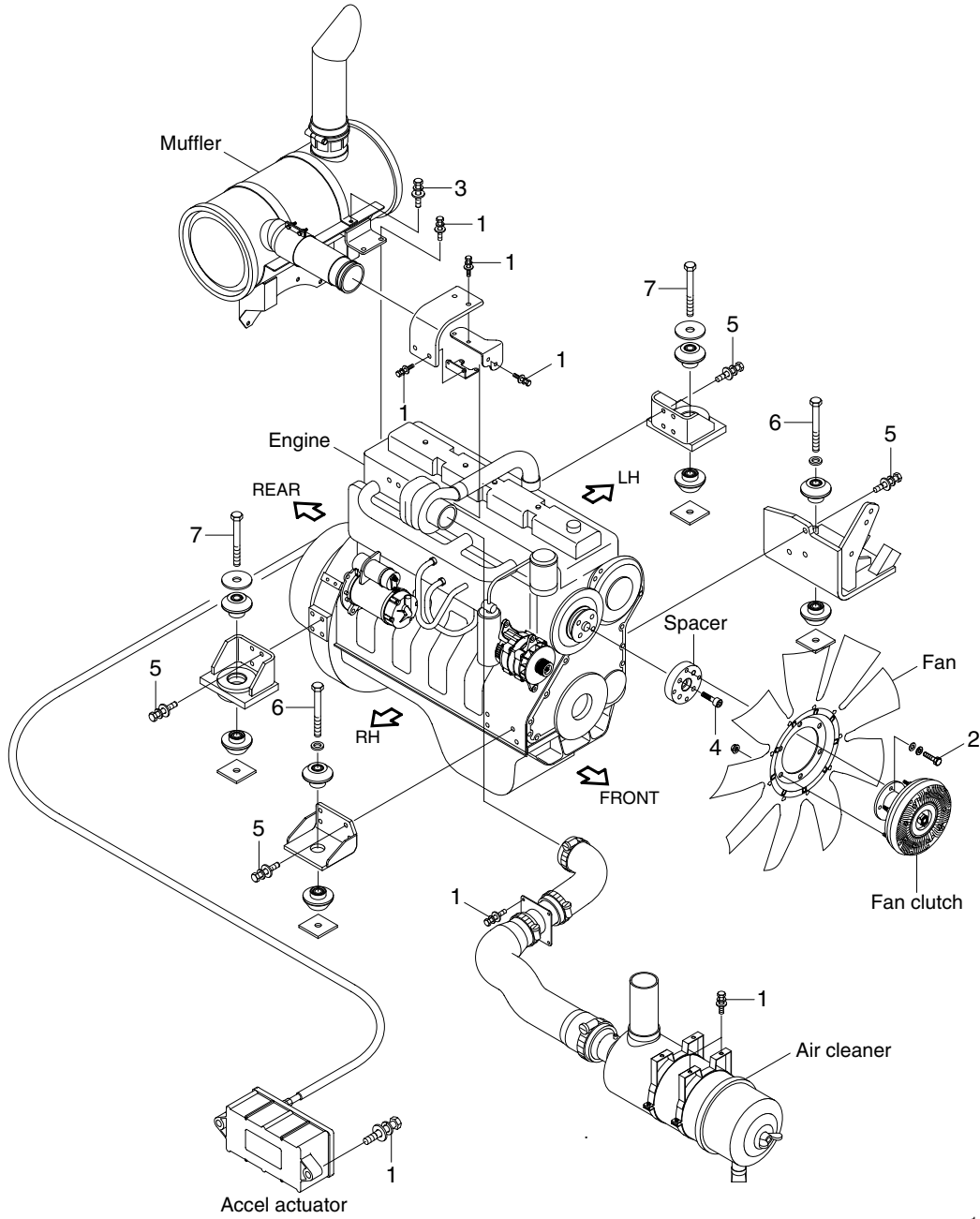

1409S9CM01

· Tightening torque

Item	Size	kgf · m	lbf · ft
1	M 8×1.25	2.5±0.5	18.1±3.6
2	M10×1.5	4.4±0.5	31.8±3.6
3	M10×1.5	6.9±1.4	49.9±10.1

Item	Size	kgf · m	lbf · ft
4	M10×1.5	8.27±1.7	59.8±12.3
5	M12×1.75	10.0±1.0	72.3±7.2
6	M16×2.0	30±3.5	217±25.3
7	M20×2.5	55±3.5	398±25.3

2. COOLING SYSTEM AND FUEL TANK MOUNTING

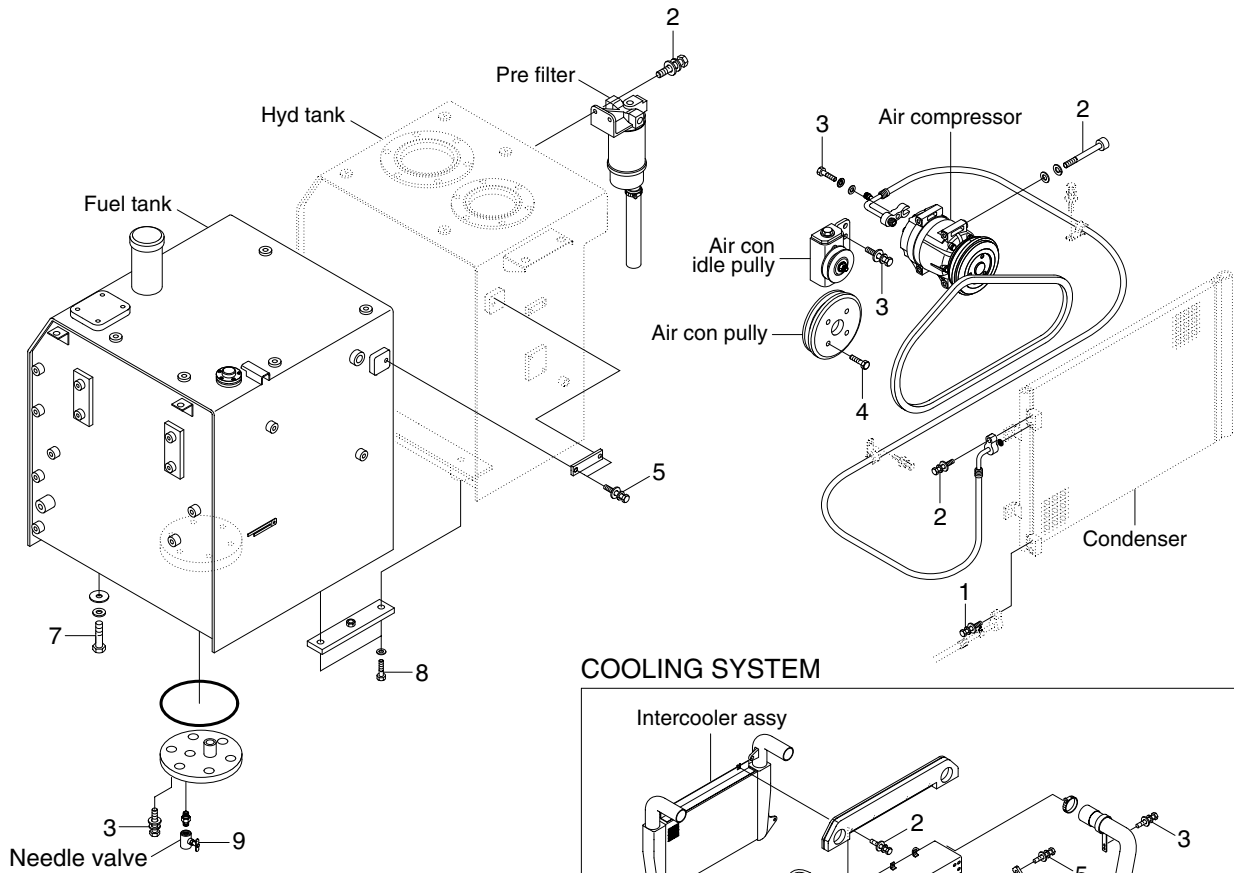

COOLING SYSTEM

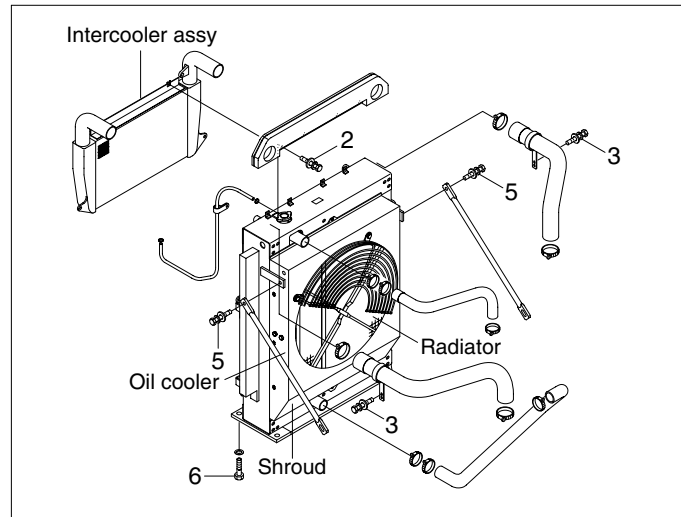

1409S9CM02

· Tightening torque

Item	Size	kgf · m	lbf · ft
1	M 6×1.0	1.05±0.2	7.6±1.45
2	M 8×1.25	2.5±0.5	18.1±3.6
3	M10×1.5	6.9±1.4	49.9±10.1
4	M10×1.5	8.3±1.7	60.0±12.3
5	M12×1.75	12.8±3.0	92.6±21.7

Item	Size	kgf · m	lbf · ft
6	M16×2.0	29.7±4.5	215±32.5
7	M20×2.5	46±5.1	333±36.9
8	M20×2.5	57.9±8.7	419±62.9
9	-	2.3±0.6	16.6±4.3

GROUP 3 ELECTRIC SYSTEM

1. ELECTRIC COMPONENTS MOUNTING 1

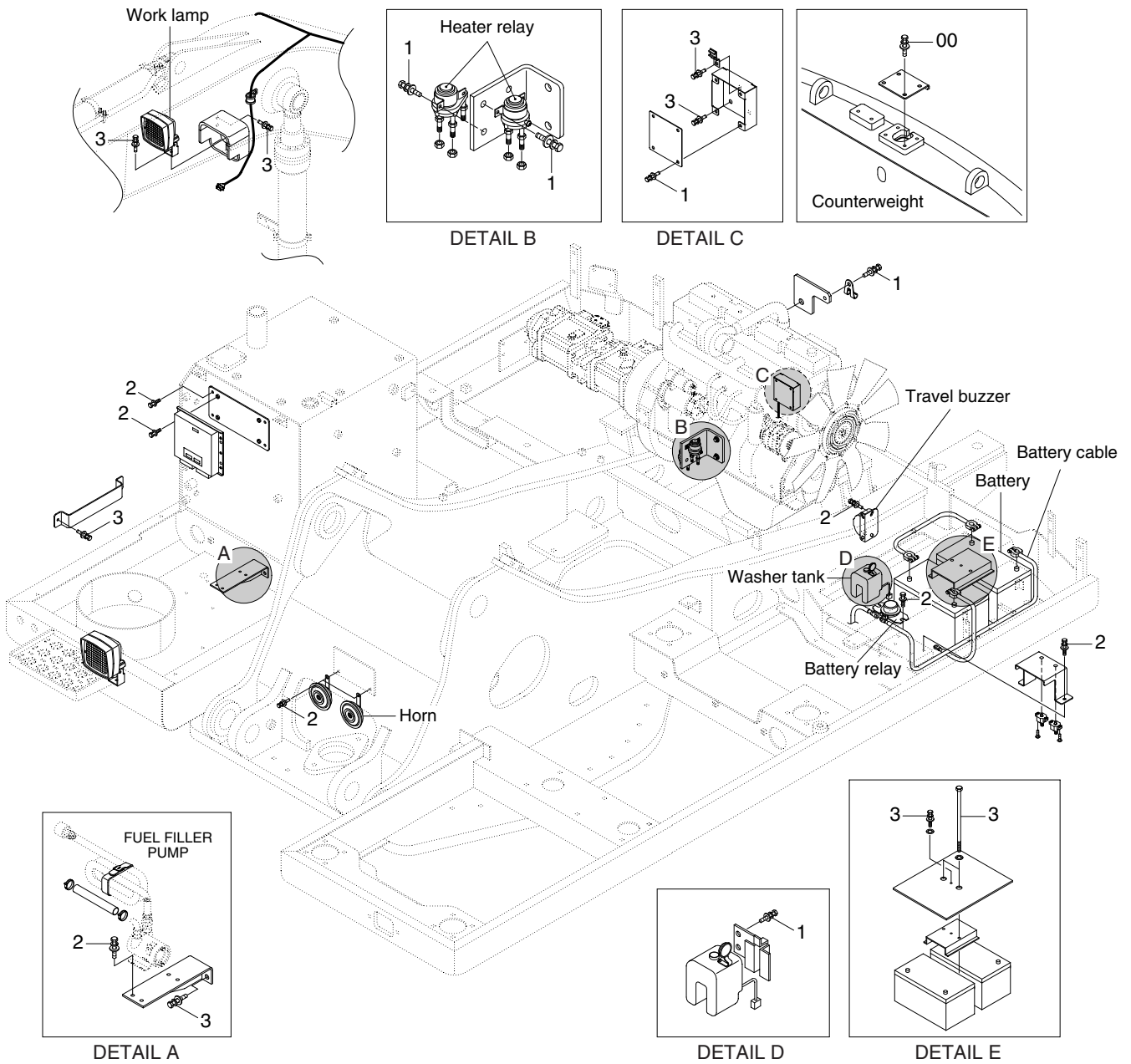

1409S9CM03

· Tightening torque

Item	Size	kgf · m	lbf · ft
1	M 6 × 1.0	1.05 ± 0.2	7.6 ± 1.45
2	M 8 × 1.25	2.5 ± 0.5	18.1 ± 3.6

Item	Size	kgf · m	lbf · ft
3	M 10 × 1.5	6.9 ± 1.4	49.9 ± 10.1

2. ELECTRIC COMPONENTS MOUNTING 2

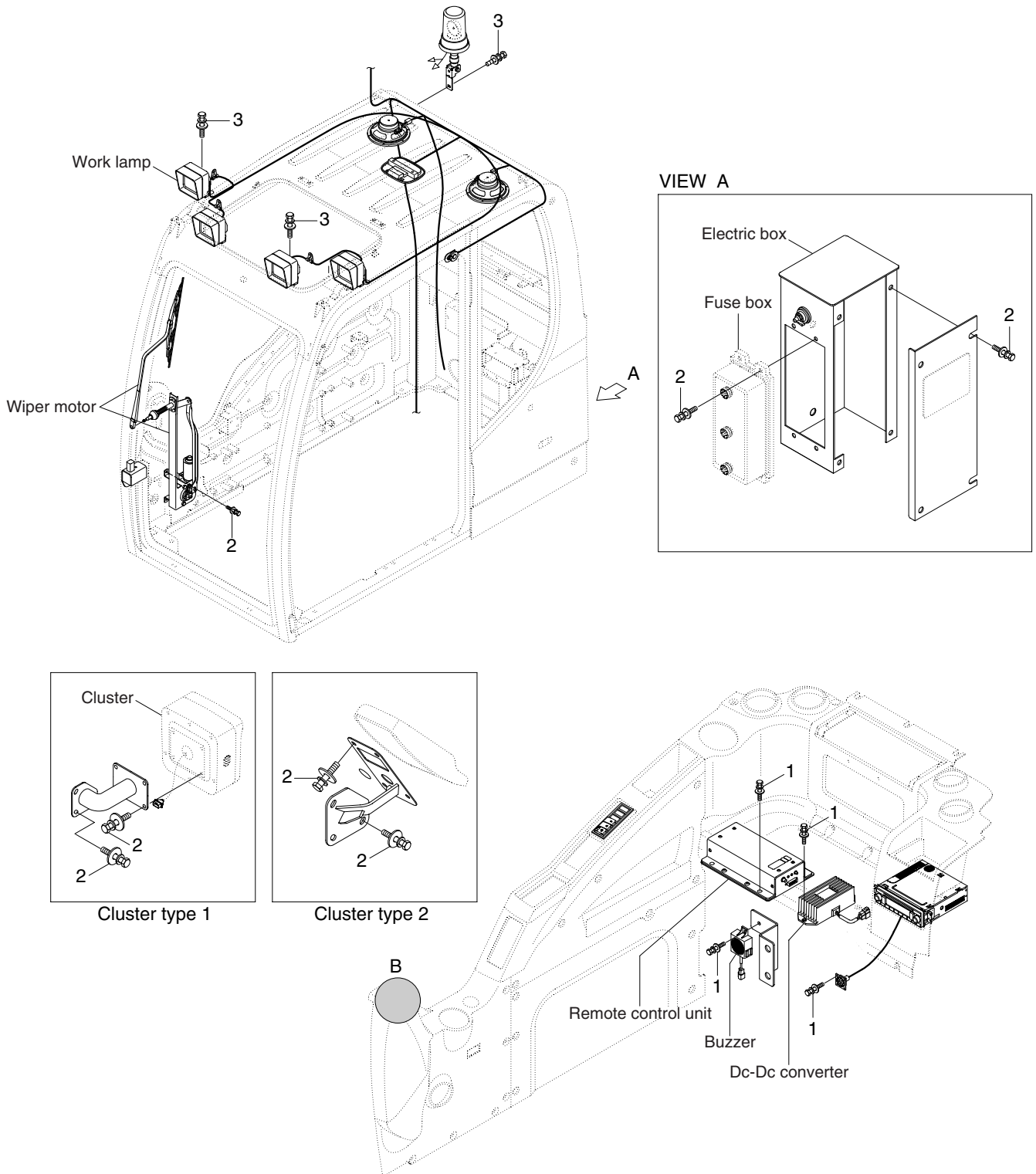

1409S9CM04

· Tightening torque

Item	Size	kgf · m	lbf · ft
1	M 6×1.0	1.05±0.2	7.6±1.45
2	M 8×1.25	2.5±0.5	18.1±3.6
3	M10×1.5	6.9±1.4	49.9±10.1

GROUP 4 HYDRAULIC SYSTEM

1. HYDRAULIC COMPONENTS MOUNTING 1

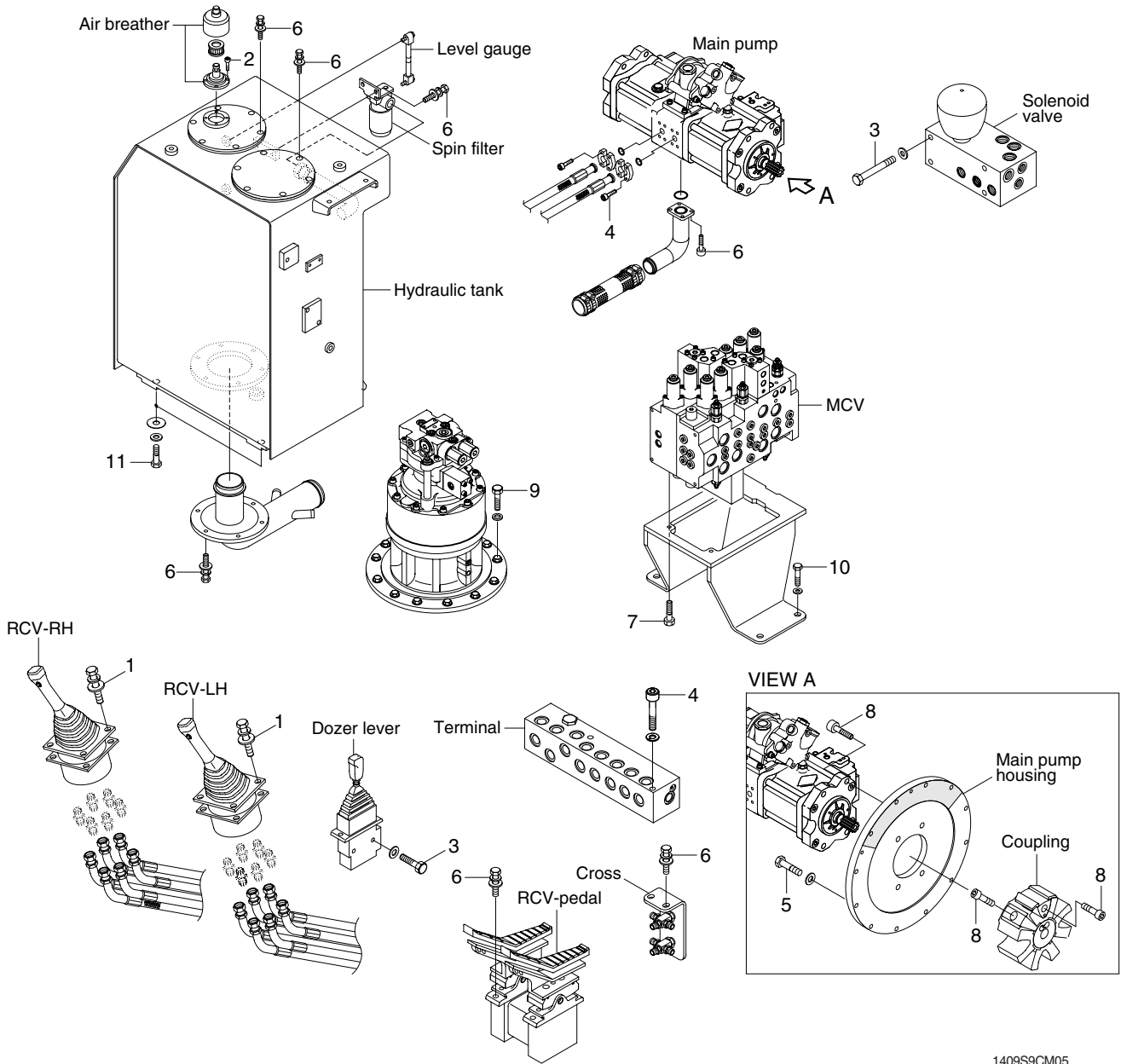

1409S9CM05

· Tightening torque

Item	Size	kgf · m	lbf · ft
1	M6×1.0	1.05±0.2	7.6±1.45
2	M6×1.0	1.44±0.3	10.4±2.2
3	M8×1.25	2.5±0.5	18.1±3.6
4	M8×1.25	4.05±0.8	29.3±5.8
5	M10×1.5	6.0±0.3	43.4±2.2
6	M10×1.5	6.9±1.4	49.9±10.1

Item	Size	kgf · m	lbf · ft
7	M12×1.75	12.2±1.3	88.2±9.4
8	M16×2.0	22±1.0	159±7.2
9	M16×2.0	29.6±3.2	214±23.1
10	M16×2.0	29.7±4.5	215±32.5
11	M20×2.5	46±5.1	333±36.9

2. HYDRAULIC COMPONENTS MOUNTING 2

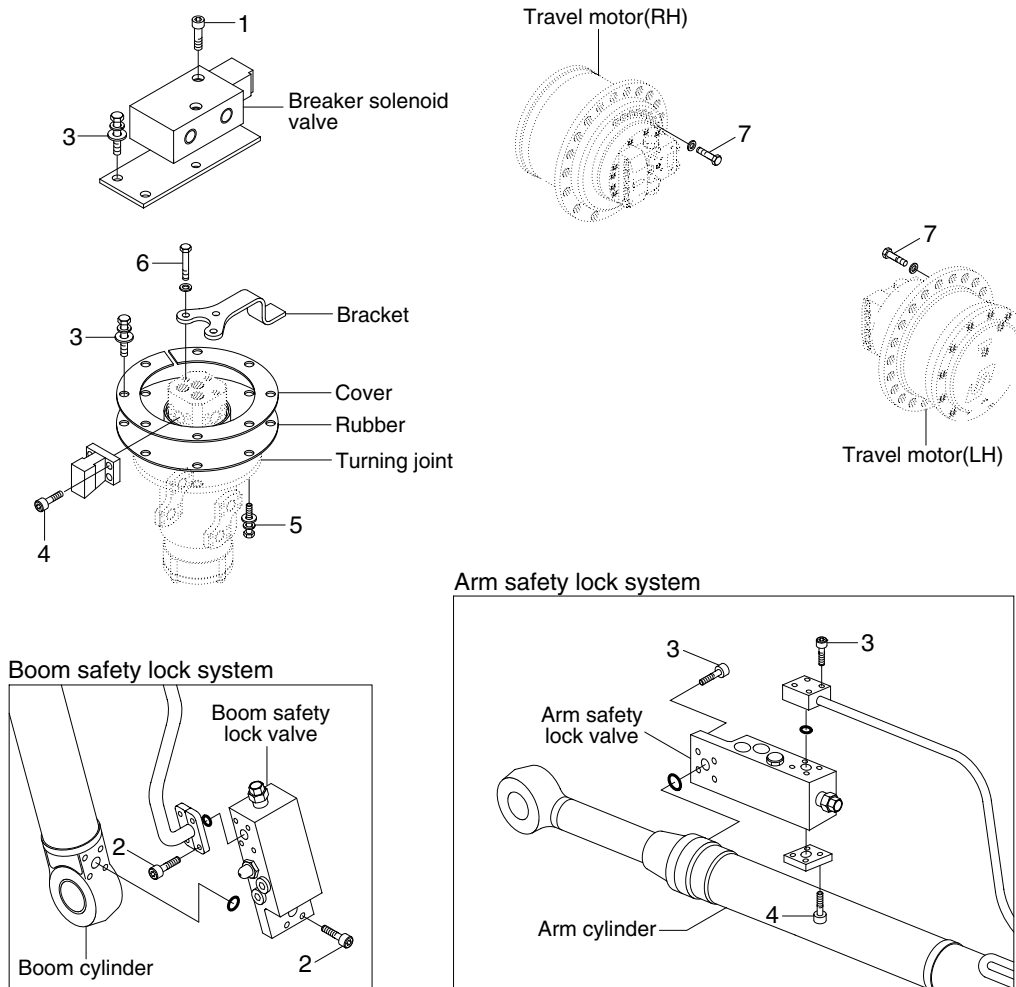

1409S9CM06

· Tightening torque

Item	Size	kgf · m	lbf · ft
1	M 8×1.25	3.43±0.7	24.8±5.1
2	M 8×1.25	4.05±0.8	29.3±5.8
3	M10×1.5	6.9±1.4	49.9±10.1
4	M10×1.5	8.27±1.7	59.8±12.3

Item	Size	kgf · m	lbf · ft
5	M12×1.75	12.3±1.3	88.9±9.4
6	M14×2.0	19.6±2.9	142±21.0
7	M16×2.0	25.7±4.0	186±28.9

3. HYDRAULIC COMPONENTS MOUNTING 3

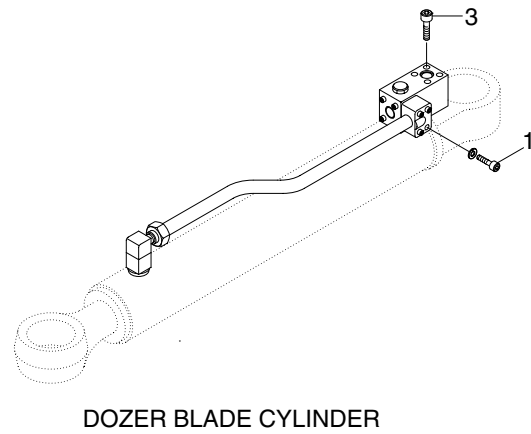
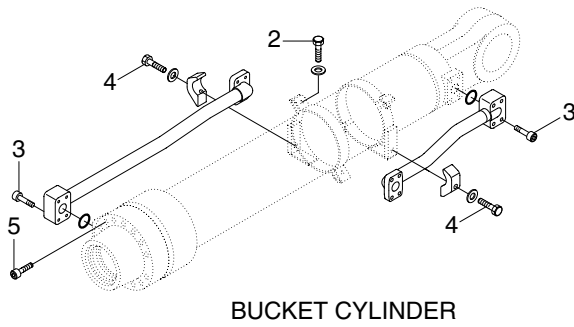
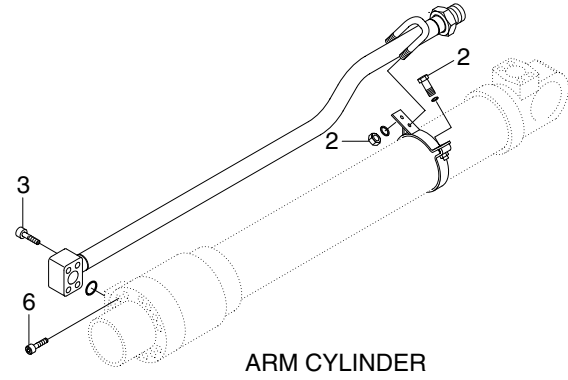
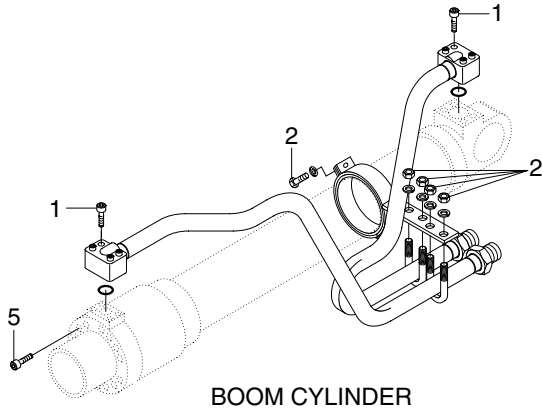

1409S9CM07

• Tightening torque

Item	Size	kgf · m	lbf · ft
1	M 8×1.25	2.7±0.3	19.5±2.2
2	M10×1.5	3.2±0.3	23.1±2.2
3	M10×1.5	5.4±0.5	39.1±3.6

Item	Size	kgf · m	lbf · ft
4	M12×1.75	9.3±1.9	67.3±13.7
5	M14×2.0	15±2.0	108±14.5
6	M16×2.0	23±2.0	166±14.5

GROUP 5 UNDERCARRIAGE

ADJUST COMPONENT

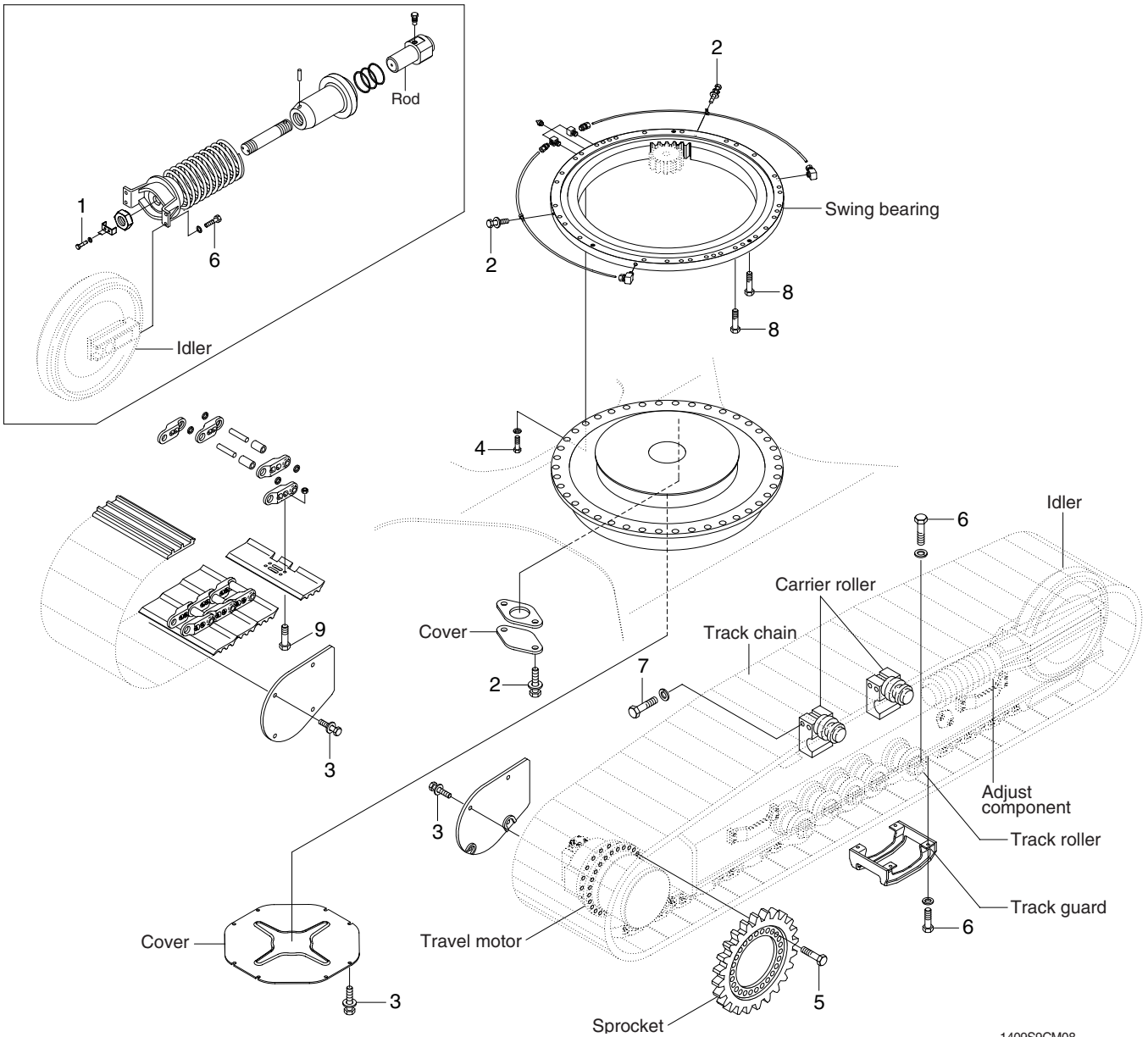

1409S9CM08

• Tightening torque

Item	Size	kgf · m	lbf · ft
1	M 8×1.0	3.74±0.7	27.1±5.1
2	M10×1.5	6.9±1.4	49.9±10.1
3	M12×1.75	12.8±3.0	92.6±21.7
4	M16×1.5	29.7±3.0	215±21.7
5	M16×2.0	23±2.5	166±18.1

Item	Size	kgf · m	lbf · ft
6	M16×2.0	29.6±3.2	214±23.1
7	M16×2.0	29.7±4.4	215±31.8
8	M18×2.5	41.3±4.0	299±29
9	5/8" UNF	42±4.0	304±29

GROUP 6 STRUCTURE

1. CAB AND ACCESSORIES MOUNTING

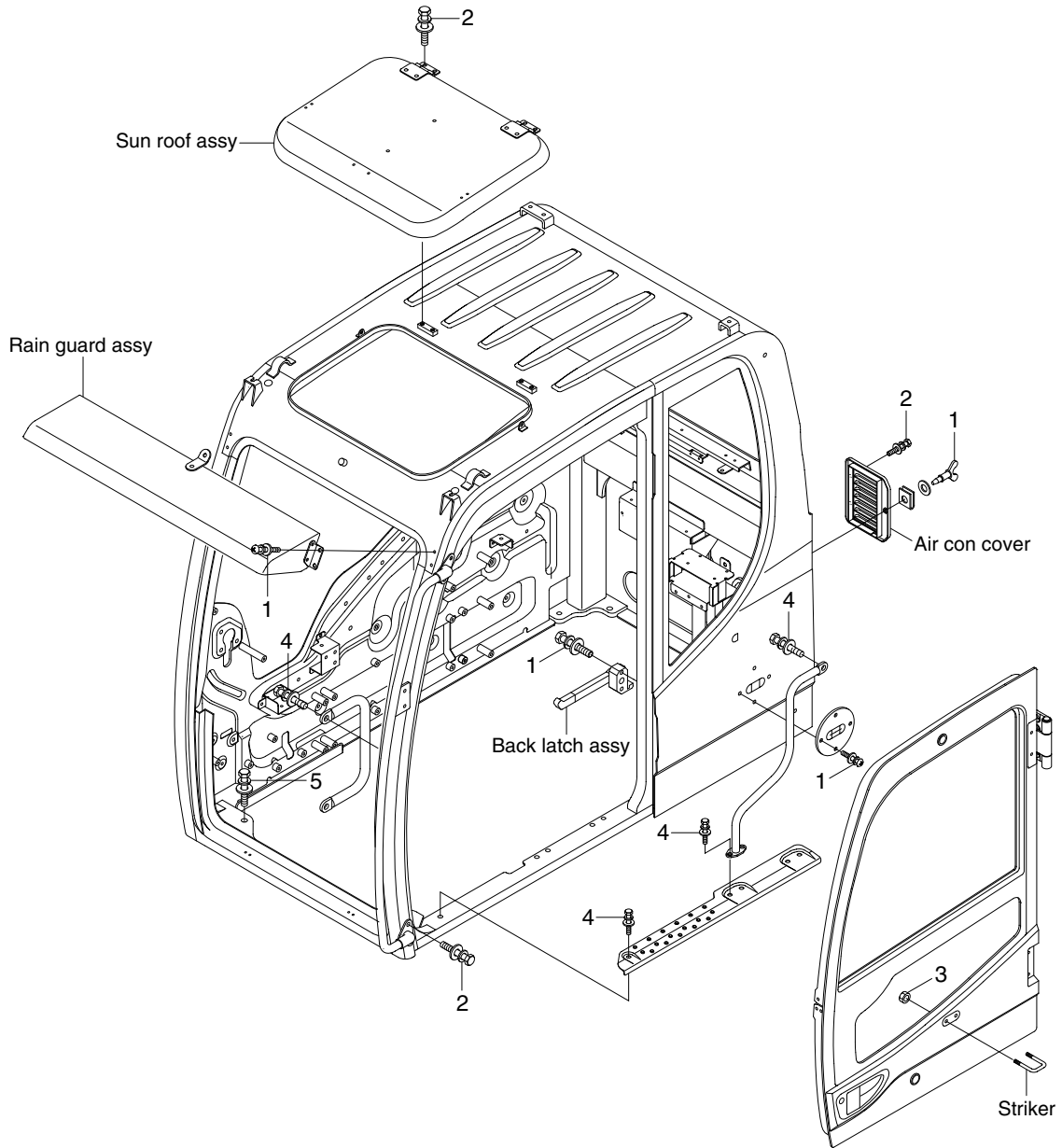

14W99CM10

• Tightening torque

Item	Size	kgf · m	lbf · ft
1	M 6×1.0	1.44±0.3	10.4±2.2
2	M 8×1.25	2.5±0.5	18.1±3.6
3	M10×1.5	4.7±0.9	34±6.5

Item	Size	kgf · m	lbf · ft
4	M10×1.5	6.9±1.4	49.9±10.1
5	M12×1.75	12.8±3.0	92.6±21.7

2. CAB INTERIOR MOUNTING

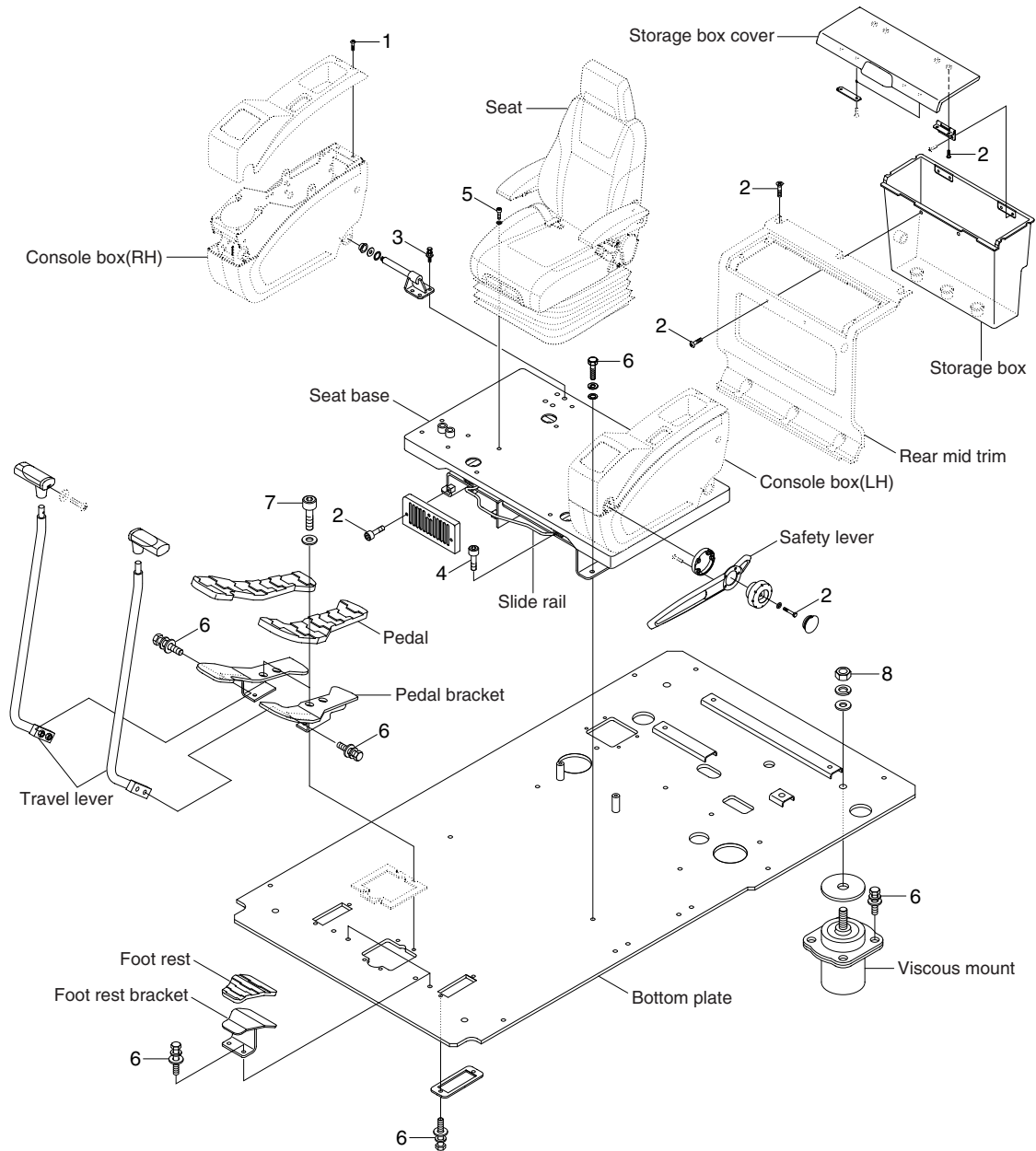

14099CM10

· Tightening torque

Item	Size	kgf · m	lbf · ft
1	M 6×1.0	0.49±0.1	3.5±0.7
2	M 6×1.0	1.05±0.2	7.6±1.4
3	M 8×1.25	2.5±0.5	18.1±3.6
4	M 8×1.25	3.43±0.7	24.8±5.1

Item	Size	kgf · m	lbf · ft
5	M 8×1.25	4.05±0.8	29.3±5.8
6	M10×1.5	6.9±1.4	49.9±10.1
7	M10×1.5	8.3±1.7	60.0±12.3
8	M16×2.0	29.7±4.5	215±32.5

3. COWLING MOUNTING

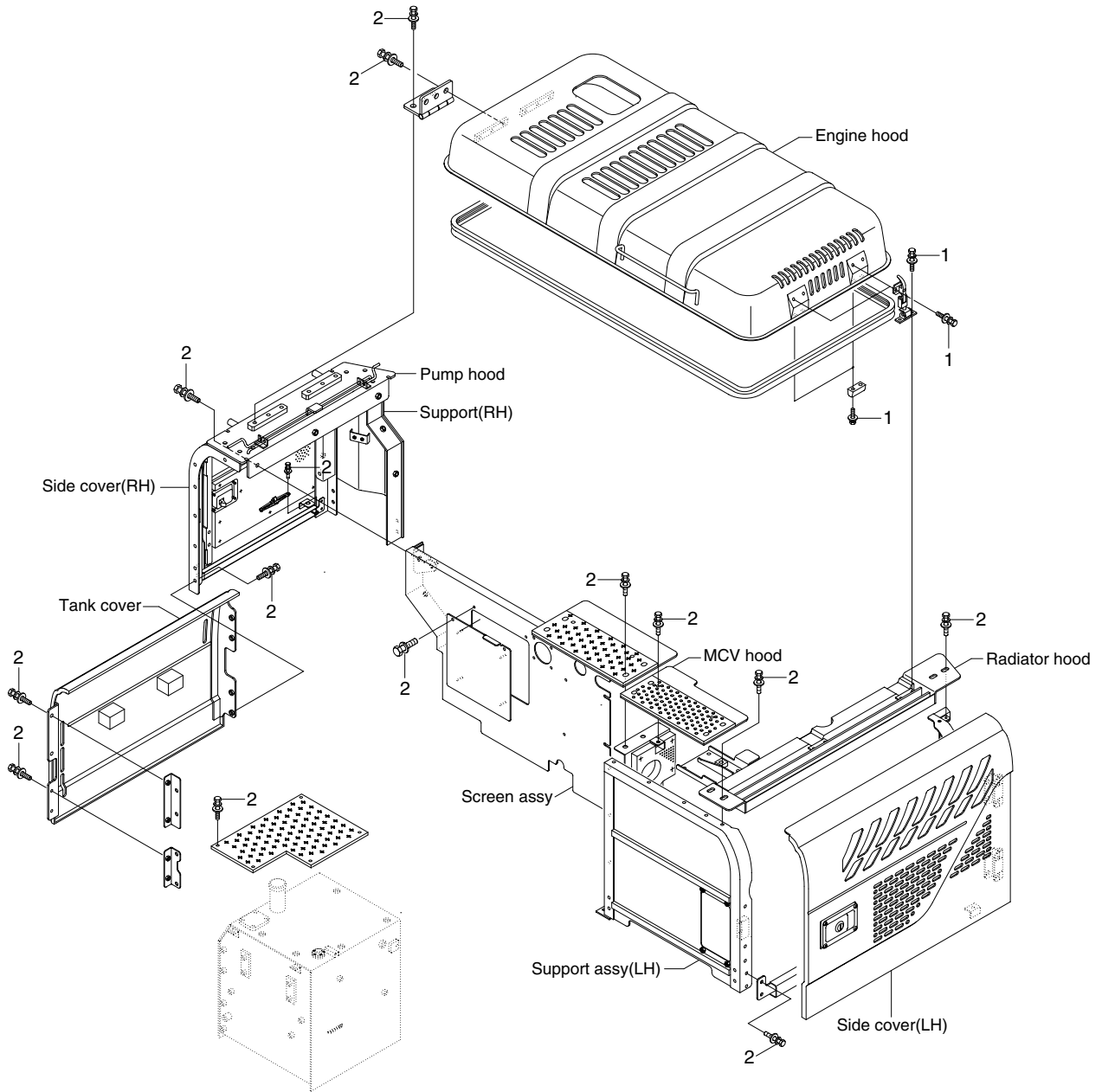

1409S9CM11

· Tightening torque

Item	Size	kgf · m	lbf · ft
1	M 8 × 1.25	1.05 ± 0.2	7.6 ± 1.4
2	M12 × 1.75	12.8 ± 3.0	92.6 ± 21.7

4. COUNTERWEIGHT AND COVERS MOUNTING

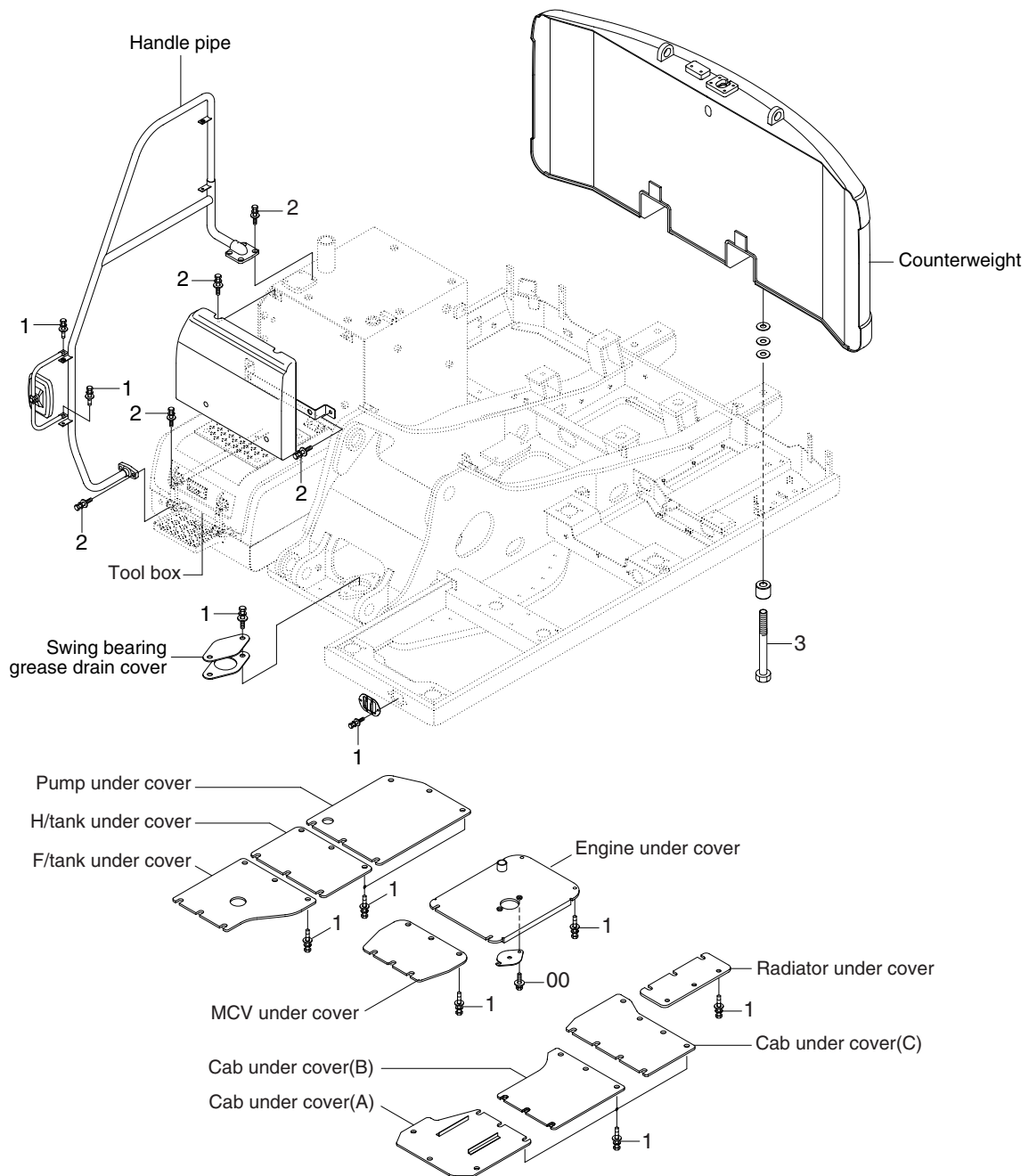

1409S9CM12

· Tightening torque

Item	Size	kgf · m	lbf · ft
1	M10×1.5	6.9±1.4	49.9±10.1
2	M12×1.75	12.8±3.0	92.6±21.7
3	M27×3.0	140±15	1013±108

GROUP 7 WORK EQUIPMENT

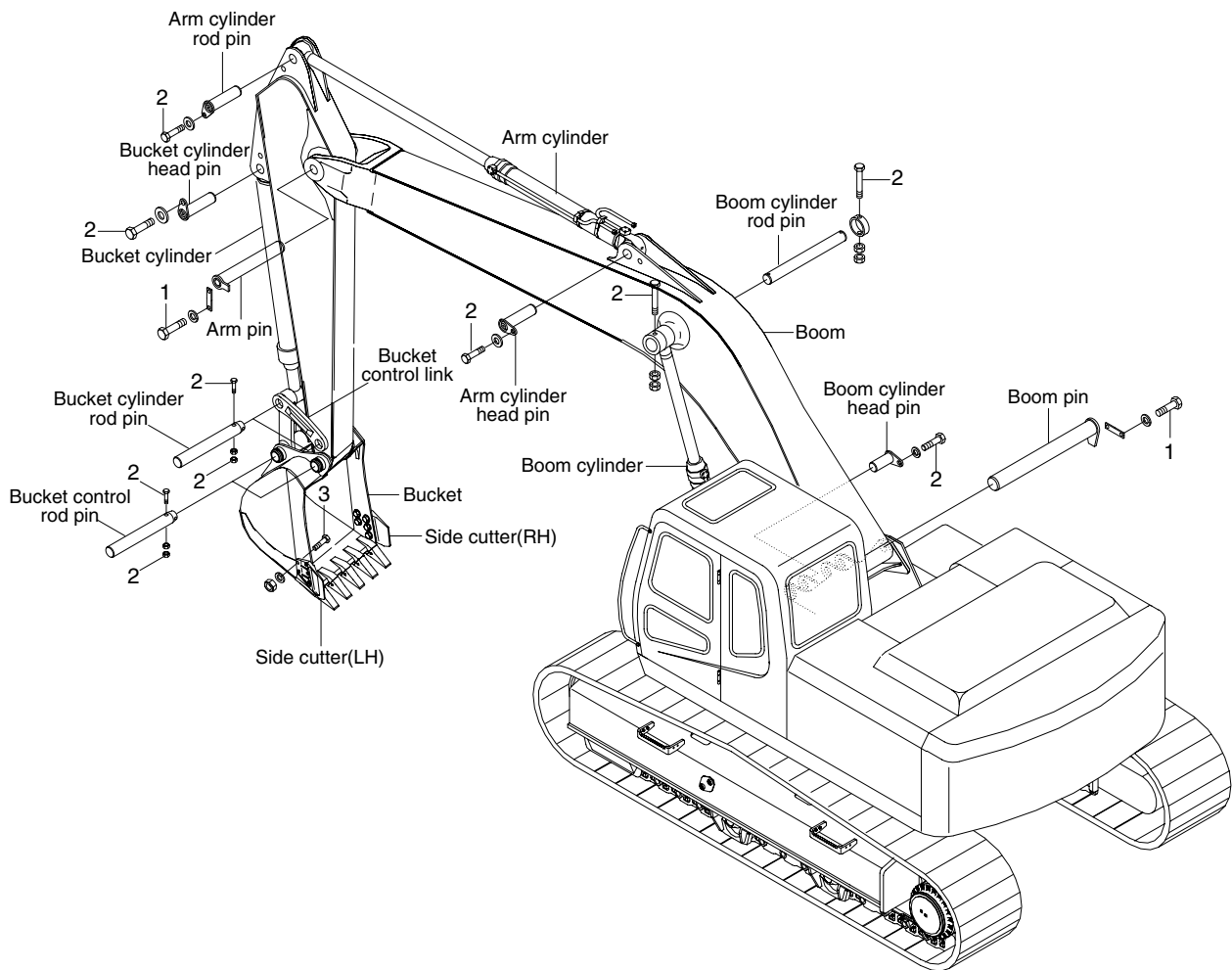

14099CM13

· Tightening torque

Item	Size	kgf · m	lbf · ft
1	M12×1.75	12.8±3.0	92.6±21.7
2	M16×2.0	29.7±4.5	215±32.5
3	M20×2.5	57.9±8.7	419±62.9