

## GROUP 6 TRAVEL DEVICE

### 1. REMOVAL AND INSTALL

#### 1) REMOVAL

- (1) Swing the work equipment 90° and lower it completely to the ground.
- (2) Loosen the breather slowly to release the pressure inside the hydraulic tank.
  - ▲ Escaping fluid under pressure can penetrate the skin causing serious injury.
  - ※ When pipes and hoses are disconnected, the oil inside the piping will flow out, so catch it in oil pan.
- (3) Remove the track shoe assembly.  
For details, see REMOVAL OF TRACK SHOE ASSEMBLY
- (4) Remove the cover.
- (5) Remove the hose.
  - ※ Fit blind plugs to the disconnected hoses.
- (6) Remove the bolts and the sprocket.
- (7) Sling travel device assembly (1).
- (8) Remove the mounting bolts (2), then remove the travel device assembly.
  - Weight : 20kg(463lb)

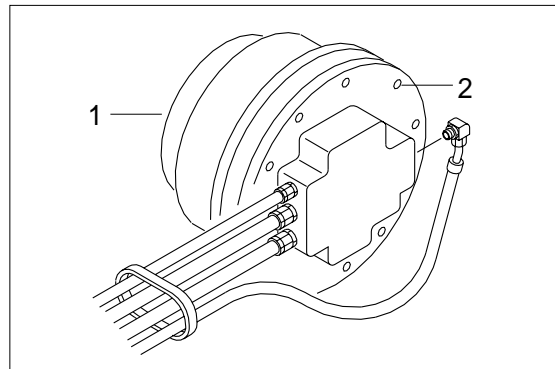

#### 2) INSTALL

- (1) Carry out installation in the reverse order to removal
- (2) Bleed the air from the travel motor.
  - ① Remove the air vent plug.
  - ② Pour in hydraulic oil until it over flows from the port.
  - ③ Tighten plug lightly.
  - ④ Start the engine, run at low idling, and check oil come out from plug.
  - ⑤ Tighten plug fully.
- (3) Confirmed the hydraulic oil level and check the hydraulic oil leak or not.

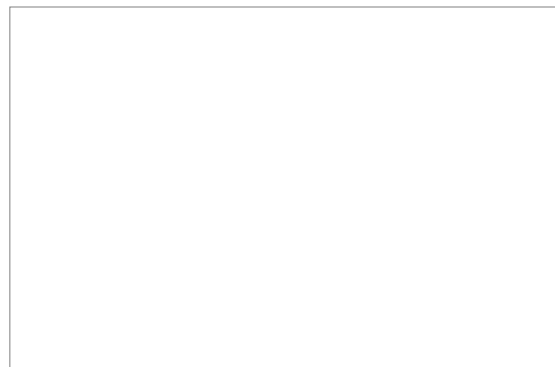
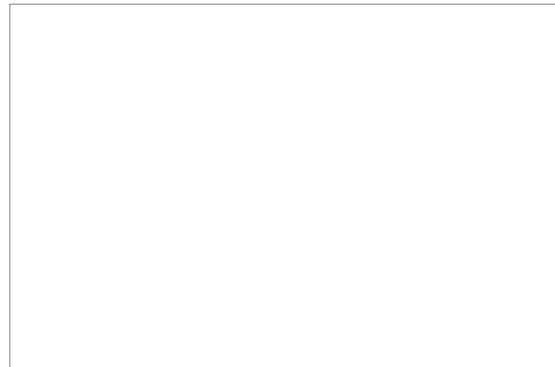

## 2. TRAVEL MOTOR

### 1) STRUCTURE (1/2)

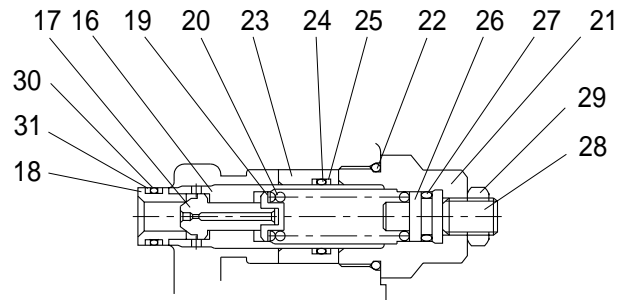

Relief valve detail

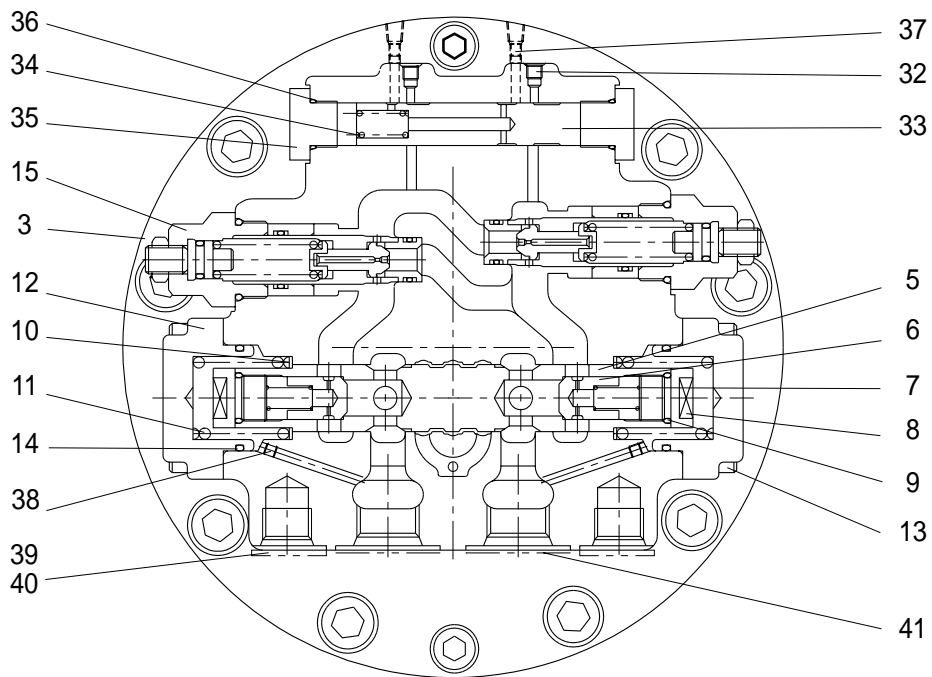

View A

2	Base plate assembly	16	Relief housing	30	O-ring
3	Base plate	17	Poppet	31	Back up ring
4	C/B valve assembly	18	Poppet seat	32	Plug
5	Plunger	19	Spring seat	33	Spool
6	Check valve	20	Spring	34	Spring
7	Spring	21	Plug	35	Plug
8	Plug	22	O-ring	36	O-ring
9	O-ring	23	Free piston	37	Orifice
10	Spring seat	24	O-ring	38	Orifice
11	Spring	25	Back up ring	39	O-ring
12	Flange	26	Spring guide	40	Plug
13	Socket head bolt	27	O-ring	41	Plug
14	O-ring	28	Set screw		
15	Relief valve assembly	29	Nut		

## STRUCTURE (2/2)

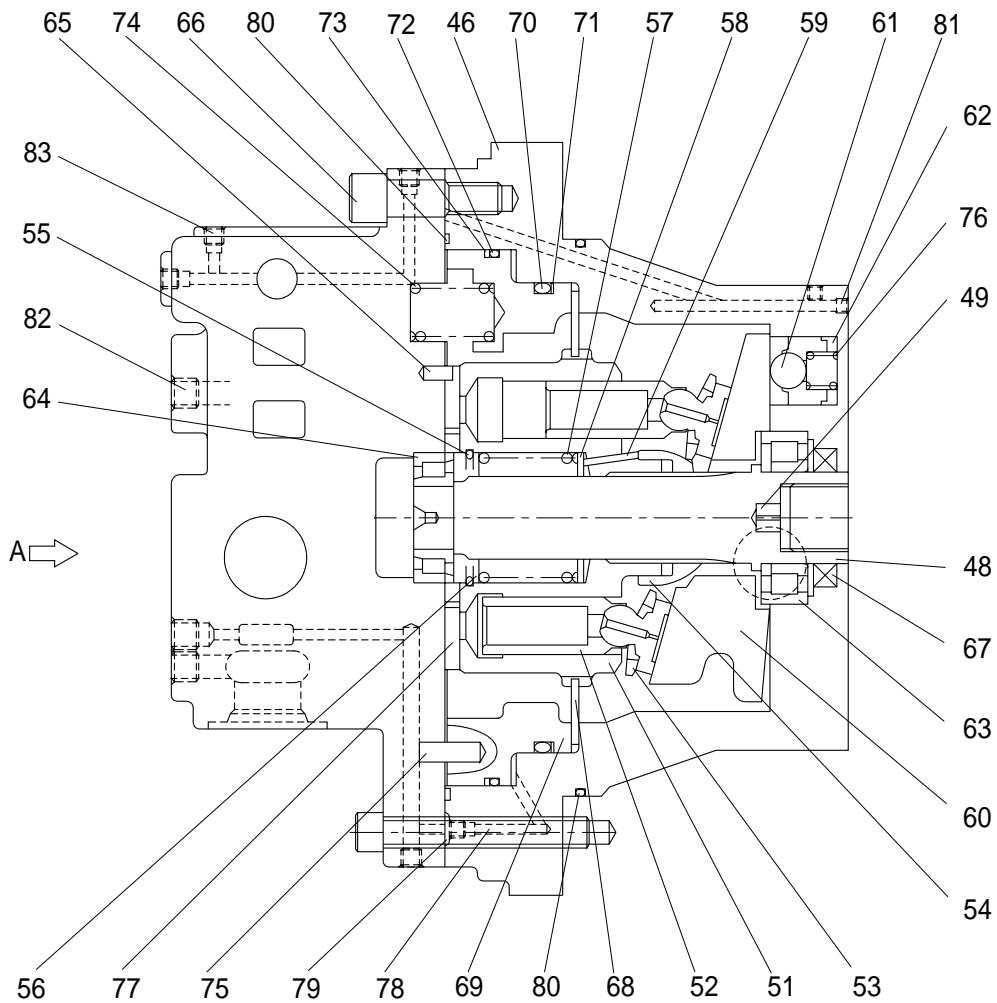

46	Casing	59	Pin	72	O-ring
47	Shaft assembly	60	Swash plate	73	Back up ring
48	Shaft	61	Steel ball	74	Spring
49	Spring	62	Piston assembly	75	Pin
50	Cylinder block assembly	63	Roller bearing	76	Spring
51	Cylinder block	64	Roller bearing	77	Valve plate
52	Piston assembly	65	Spring pin	78	Orifice
53	Retainer plate	66	Socket head bolt	79	O-ring
54	Retainer holder	67	Oil seal	80	O-ring
55	Snap ring	68	Disc plate	81	Plug
56	Collar	69	Brake piston	82	Plug
57	Spring	70	O-ring	83	Plug
58	Collar	71	Back up ring		

## 2) TOOLS AND TIGHTENING TORQUE

### (1) Tools

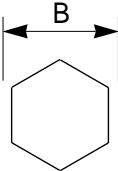
Tool name	Remark	
Allen wrench	2.5	
	4	
	6	
	8	
	14	
Socket for socket wrench	27	
Spanner	27	
Torque wrench	Capable of tightening with the specified torques.	
Pliers	-	
( - ) Driver	6 × 100	
Hammer	Steel and plastic	
Eye bolt	M10, M16	

### (2) Tightening torque

Part name	Item	Size	Torque		Wrench size	
			kgf · m	lbf · ft	in	mm
Plug	8	M 20	10 ~ 12	72.3 ~ 86.8	0.75	19
Socket head bolt	13	M 20	5.5 ~ 6.5	39.8 ~ 47.0	0.31	8
Relief valve	15	-	36 ~ 40	260.4 ~ 289.3	1.06	27
Plug	33,82	NPT 1/16	0.9 ~ 1.1	6.5 ~ 8.0	0.16	4
Plug	36	PF 3/8	4.8 ~ 5.4	34.7 ~ 39.1	0.31	8
Orifice	38, 39, 78	M 5	0.2 ~ 0.3	1.4 ~ 2.2	0.10	2.5
Socket head bolt	66	M 16	28 ~ 32	202.5 ~ 231.5	0.55	14
Plug	83	PT 1/4	1.5 ~ 2	10.8 ~ 14.4	0.24	6

### 3) DISASSEMBLY

#### (1) Fixed the motor

Direct the output shaft up and fix the base plate (3) in a vise.

#### (2) Disassembling the base plate assembly

##### ① Disassembling the relief valve assembly.

Loosen plug(21) and remove the relief assembly(15).

The plug(21) is lightly pressed into the relief housing(16), but in case it comes off, hold and turn the outer periphery of the relief housing(16) to separate them.

※ If nut(30) and setscrew(29) are loosened to remove the relief valve assembly (15), the set relief pressure will vary. Therefore, do not loosen them.

Do not disassemble the relief valve assembly except when necessary.

※ When holding the periphery of the relief valve housing with pincers, protect it with rag or something to protect the outer.

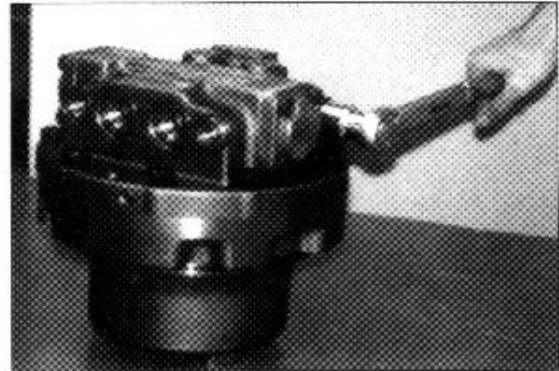

##### ② Disassembling the Double Counterbalance valve.

Loosen socket bolts(13) and remove the flange(12).

※ Since the flange(12) is held down by spring(11), loosen the socket bolts(13) halfway and hold the flange(12) down till the socket bolts(13) come off.

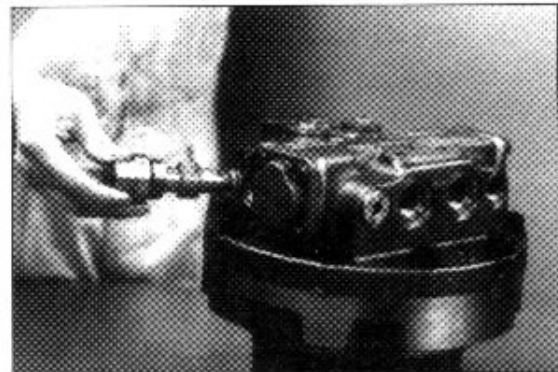

- ③ Remove spring seat(10) and spring(11).

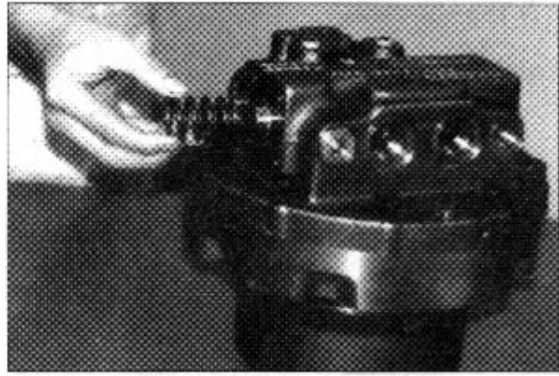

- ④ Draw out the plunger assembly(4).  
※ Draw it out, turning it slowly.

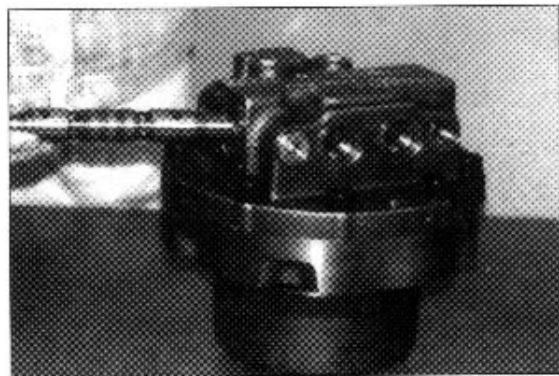

- ⑤ Disassembling the 2-speed control valve.  
Loosen plugs(36) and remove spring (35) and spool(34).  
※ Draw out it, by turning is slowly.

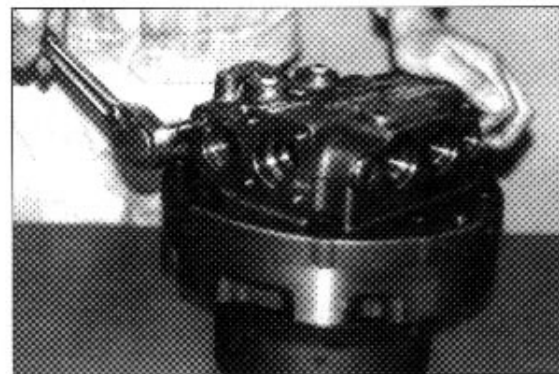

**(3) Disassembling the base plate**

- ① Loosen socket bolts(66).  
※ Loosen the bolts evenly as the base plate(3) is pushed up by spring(74).

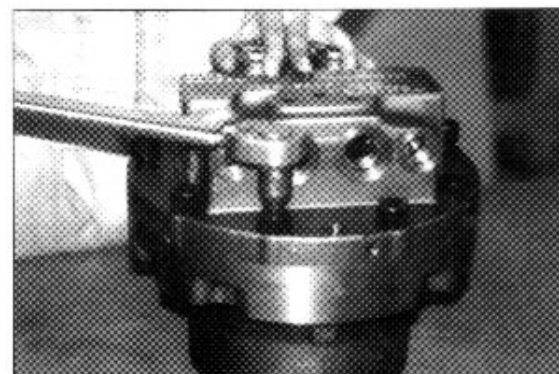

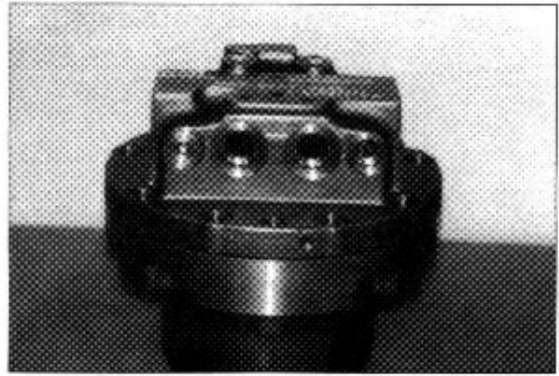

② Remove socket bolts(66) and take off base plate assembly(3), using a screwdriver.

※ Do not pry the base plate assembly gerkily with a screwdriver.

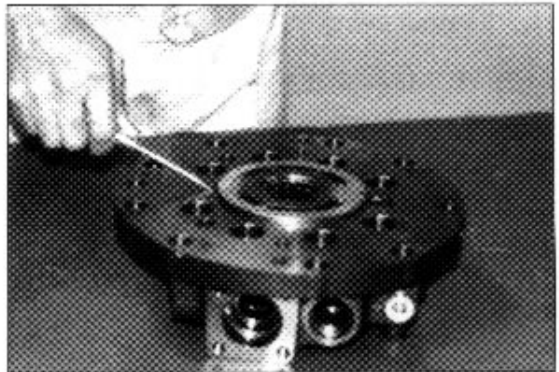

③ Separate valve plate(77), pins(75), O-ring(79, 80) and spring(74) from base plate(3).

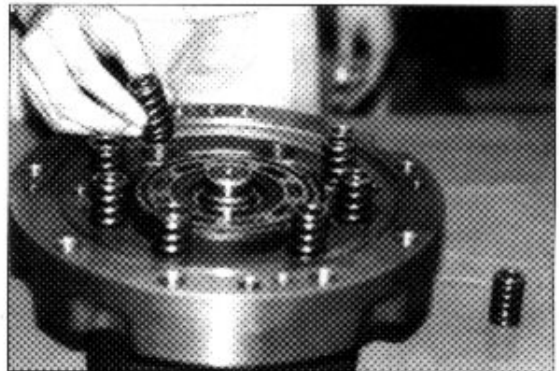

- ④ Remove O-ring(79, 80) from casing(1).

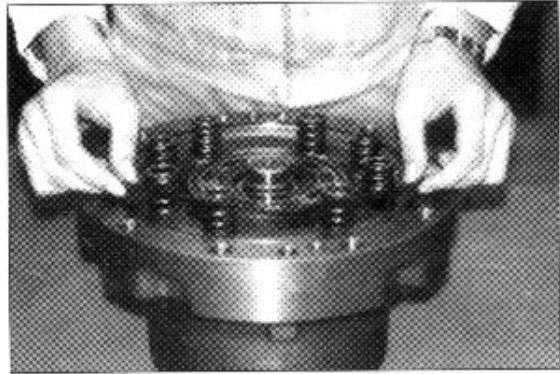

#### (4) Disassembling the brake piston

- ① Separate brake piston(69) from casing (1), using jet air and utilizing the pilot port hole of the casing(1).  
② Remove disc plate(68).  
※ Brake piston(69) may pop up by air pressure. Therefore, use care to avoid danger by utilizing a pop-out preventing jig or something.



#### (5) Disassembling the cylinder block assembly

- ① With casing(1) placed on the side on the work bench, draw out the cylinder block assembly(50) from casing(1).

※ Be cautious not to damage on sliding face of cylinder.

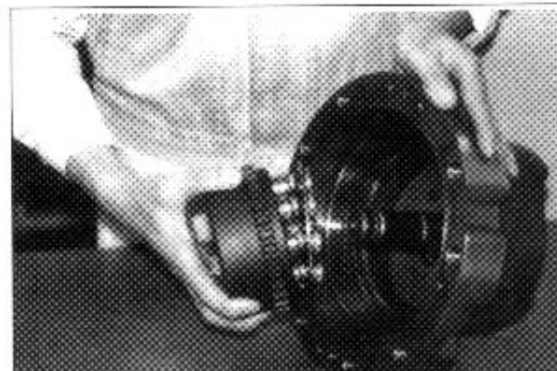

- ② Draw out piston assembly(52) from cylinder block(51), separate retainer plate(53), retainer holder(54) and pin(59) and disassemble the cylinder block.

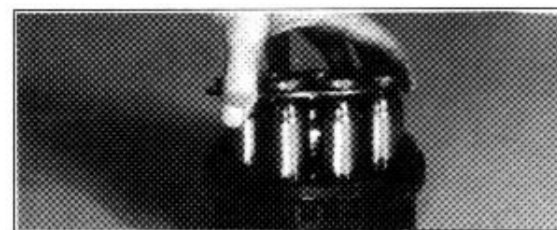



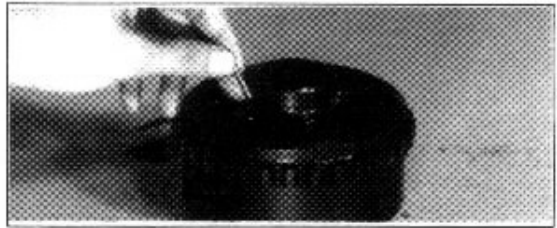

- ③ Remove snap ring(55) using a jig and separate collar(56), spring(57) and collar(58).

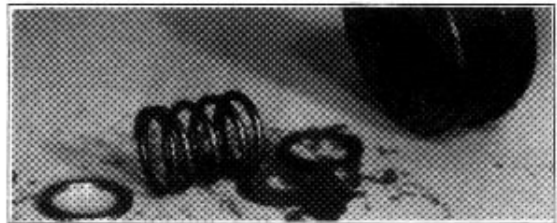
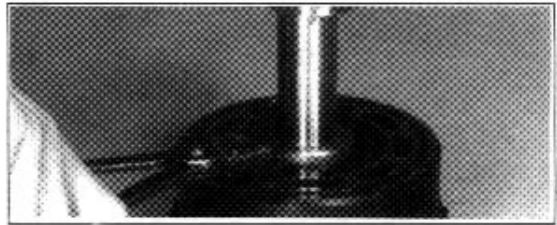

- (6) Separate shaft(40) from casing(1).
- (7) Separate swash plate(60) from casing(1) and then take off steel ball(61), spring (76) and piston assembly(62).
- ※ Steel balls(61) can easily be taken out if a magnet is used.

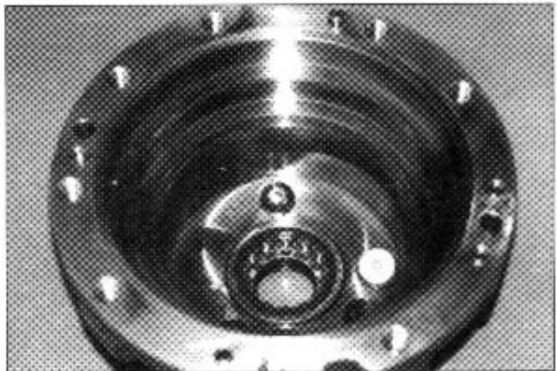

**(8) Disassembling the plunger assembly**

- ① Fit round bar ( $\varnothing 10$ ) into plunger(5) and fix in a vise and then remove plug(8).

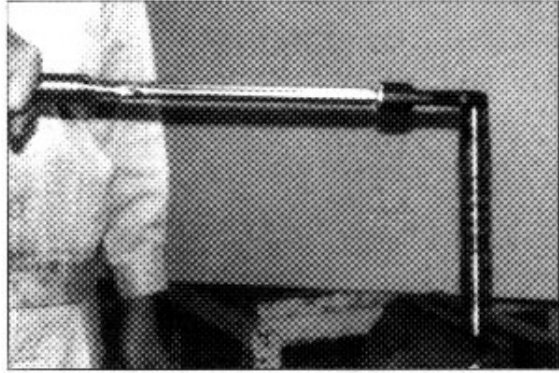

- ② Separate spring(7) and check valve(6).

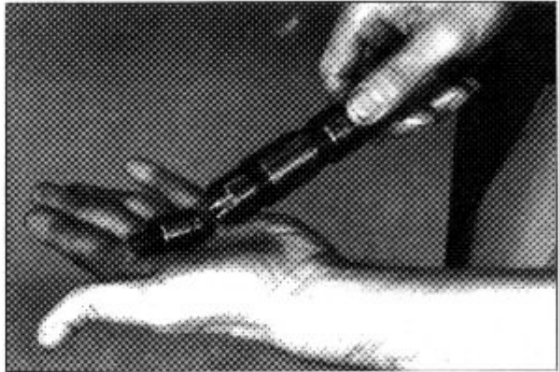

This completes disassembly.

#### 4) ASSEMBLY

##### (1) Precautions

- ① Clean parts with clean washing oil and blow it with jet air.
- ② Handle cleaned parts with care to be free from dust and scoring.
- ③ Replace seals, bearings and pins with new ones.
- ④ Tighten the fastening parts to specified torques.
- ⑤ Coat oil seals and O-rings with grease. (oil seal lip, in particular)

##### (2) Assembling the cylinder block assembly

- ① Fix collar(58), spring(57) and collar(56) to cylinder block(51) in that order and then fit snap ring(55).

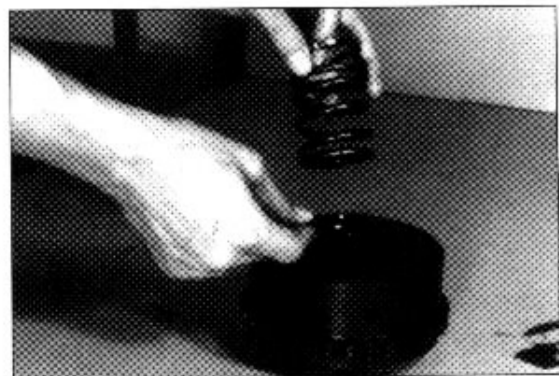
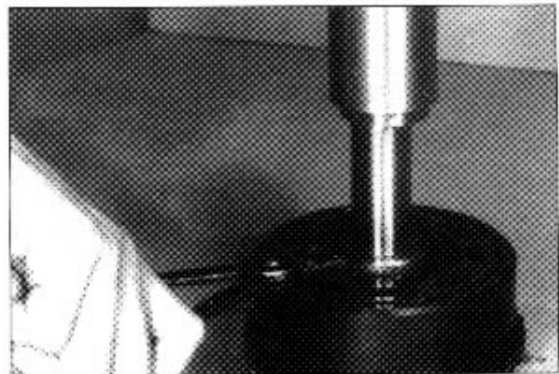

- ② Fix pin(59) and retainer holder(54) to cylinder block(51).

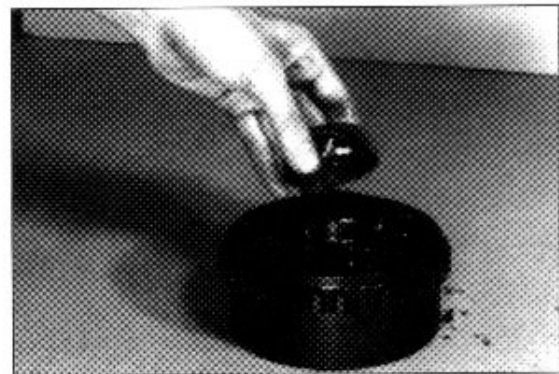

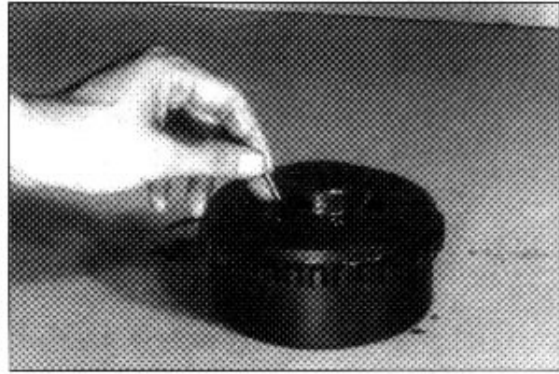

③ Fix piston assembly(52) to retainer plate(53) and fit it into cylinder block (51).

※ Fix the retainer plate so the small diameter part of the retainer plate bore taper comes in contact with the flange of the piston shoe. Fix it after coating the piston hole with hydraulic oil.

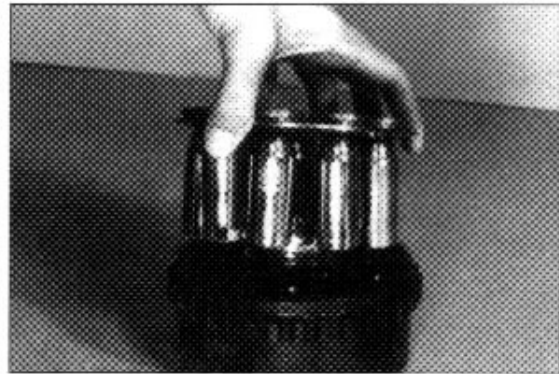

### (3) Fixing Casing(1)

- ① Place a suitable jig on a work bench and mount casing(101) on it.
- ② Fix spring(76), piston assembly(62) and steel ball(61) to casing(1).

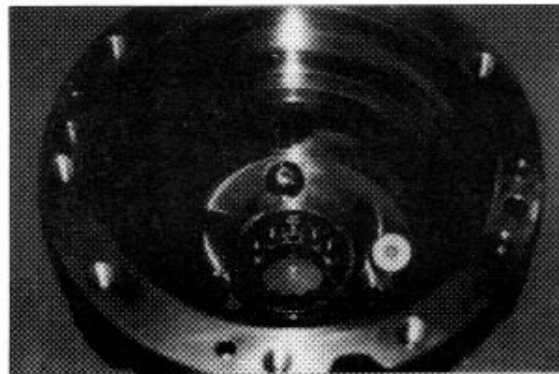

③ Fix shaft(40) to casing(1).

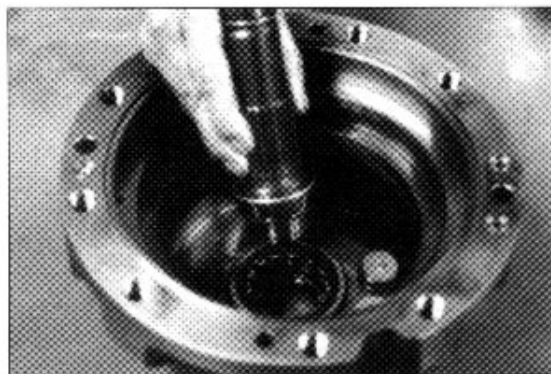

④ Fix swash plate(60) to casing(1).

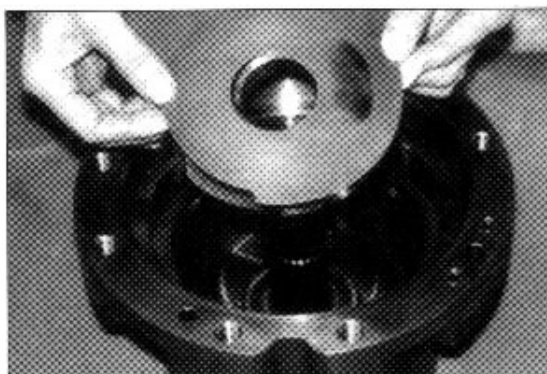

⑤ Insert the cylinder block assembly(50) into casing(1) and assemble them together.

Insert the cylinder block so piston assembly(62) and retainer holder(54) may not come off.

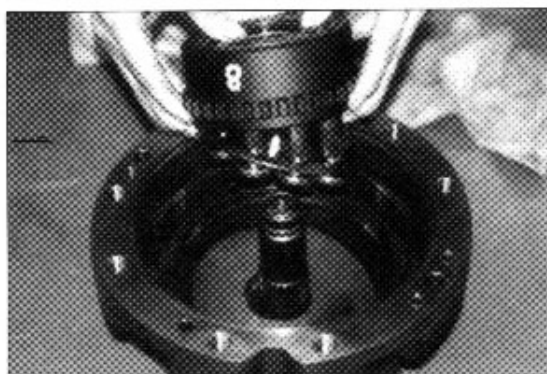

⑥ Fix disc plate(68) to casing(1)



- ⑦ Fix O-ring(70, 72) and back up ring(71, 73) to brake piston(69).

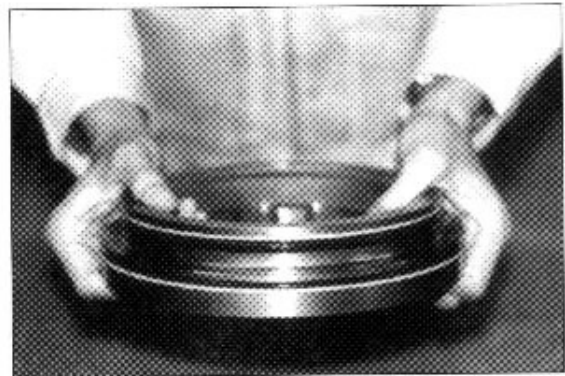
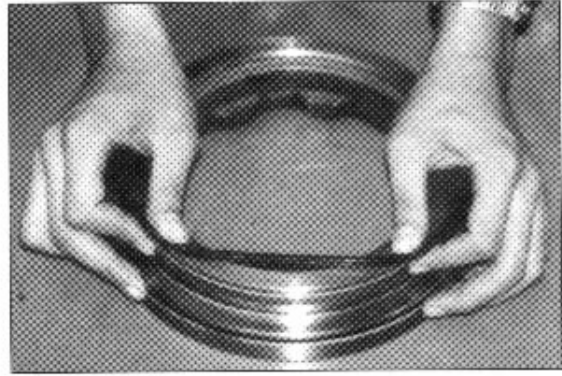

- ⑧ Fix brake piston(69) to casing(1).

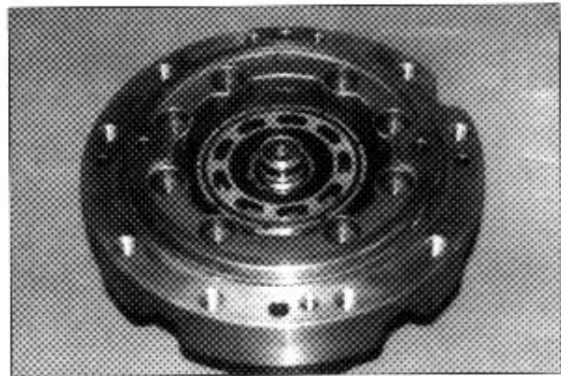

- ⑨ Place a suitable jig on the brake piston and insert brake piston by tapping with plastic hammer.

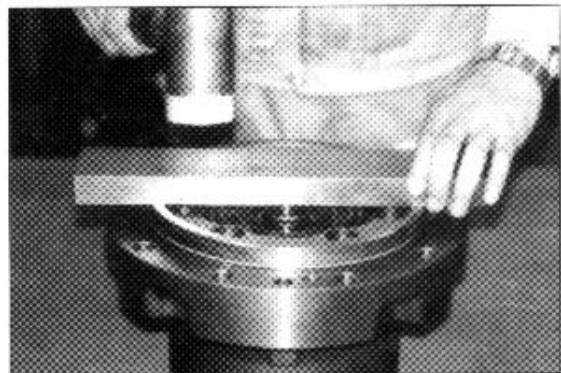

⑩ Fix O-ring(79, 80) to casing(1).

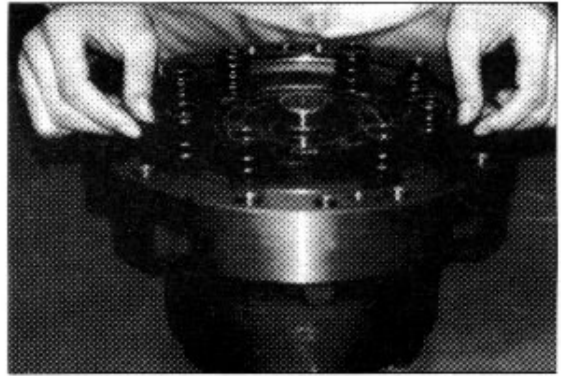

⑪ Fix spring(74) to brake piston(69).

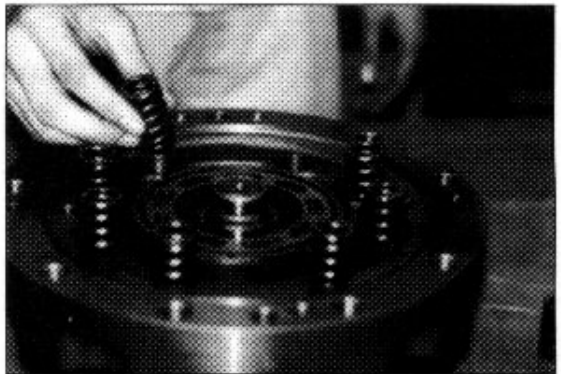

#### (4) Assembling the base plate

- ① Place a suitable jig on a work bench and mount base plate(3) on it.
- ② Fix the out race of roller bearing(64) to base plate(3).
- ③ Fix pin(75), spring pin(65) and valve plate(77) to the base plate(3).

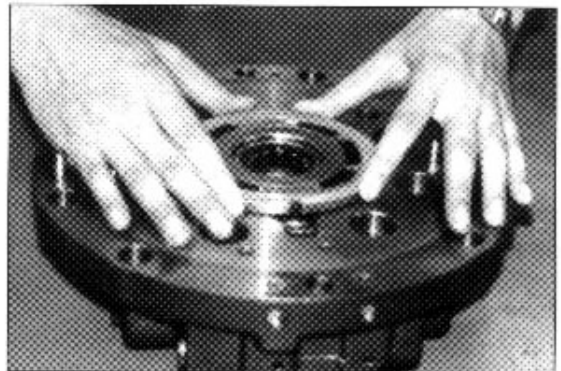

#### (5) Assembling the base plate

- ① Fix base plate(3) to casing(1).
- ※ Fix cylinder block(51) and valve plate (77) after applying hydraulic oil to them.



② Tighten socket bolts(66).

※ Tightening torque : 10 ~ 11 kgf · m

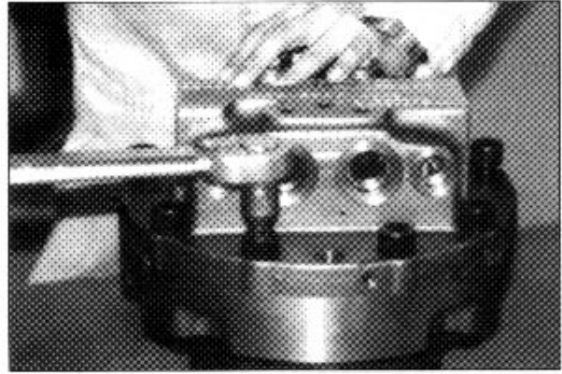

### (6) Assembling the plunger

① Fix round bar(φ 10) into plunger(4) and fix it in a vise.

Fix check valve(6) and spring(7) to plunger(5).

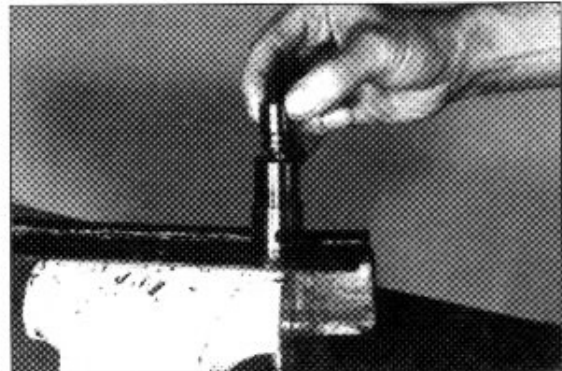

② Fix O-ring(9) and plug(8) to plunger(5).

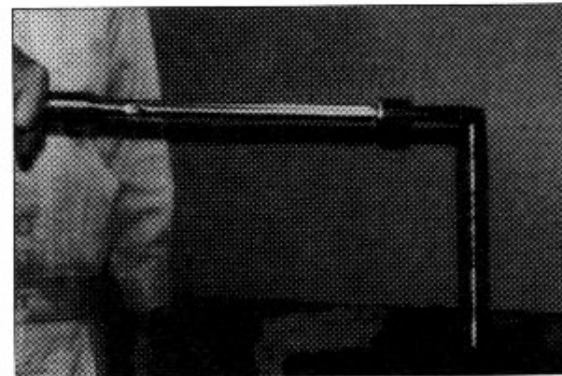

③ Fix plunger(4) to base plate(3).

※ Before assembling, applying hydraulic oil to sliding surface of plunger.

※ Fix plunger(4) by turning it slowly and confirm that it slides smoothly.

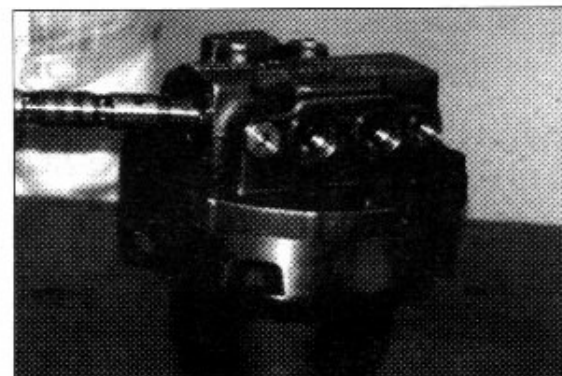



④ Fit spring seat(10) and spring(11).

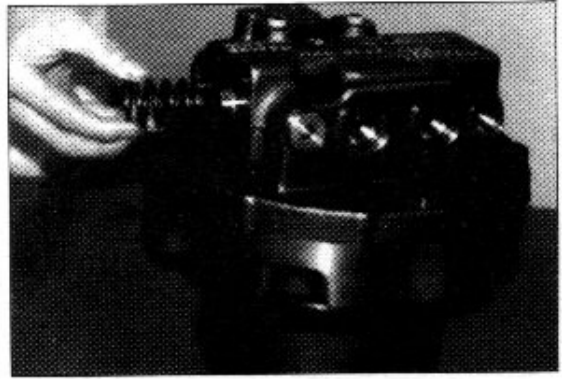

⑤ Fit flange(12) to base plate(3) and fasten them with socket bolts(13) together.

※ Since it is pushed by spring(11), tighten socket bolts(13), holding it down by hand.

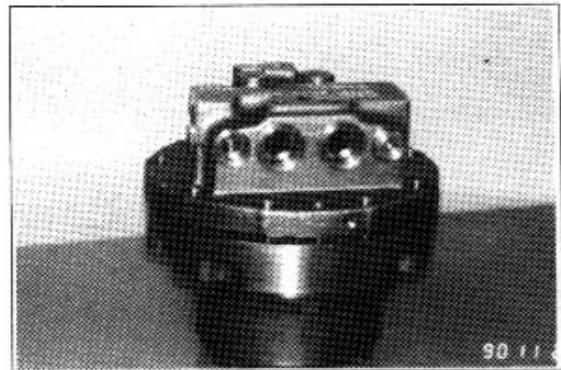
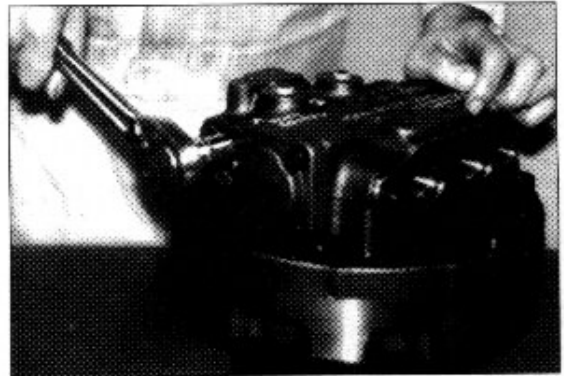

(7) Fit relief valve(15) to base plate(3) and tighten specified torque.



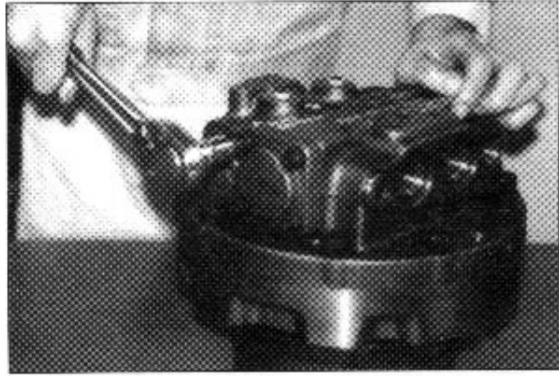

(8) Fit spool(34), spring(35) to base plate(3)  
and tighten plug(36).

※ Pay attention to spool direction.

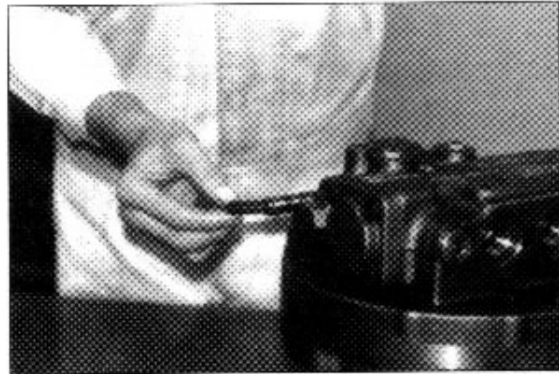

### 3. TRAVEL REDUCTION GEAR

#### 1) STRUCTURE

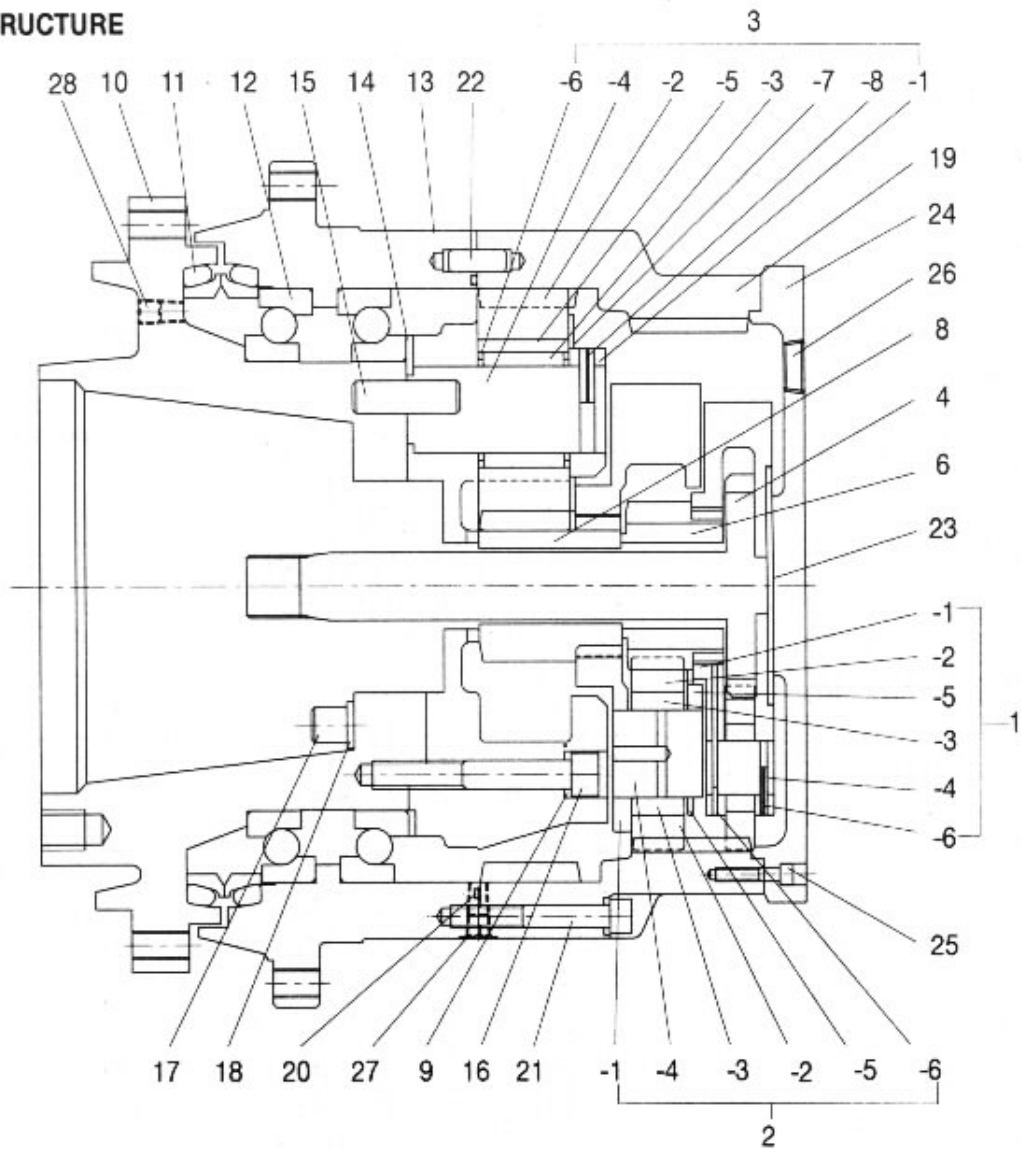

1	Holder A assembly	3-2	Planet gear C	14	Shim(0.1~0.05t)
1-1	Holder A	3-3	Roller bearing	15	Pin
1-2	Planet gear A	3-4	Gear shaft C	16	Socket head bolt
1-3	Needle bearing	3-5	Floating seal	17	Socket head bolt
1-4	Gear shaft A	3-6	Collar	18	Plate
1-5	Thrust washer	3-7	Thrust washer	19	Ring gear
1-6	Spring pin	3-8	Spring pin	20	O-ring
2	Holder B assembly	4	Drive gear	21	Socket head bolt
2-1	Holder B	5	Thrust plate	22	Pin
2-2	Planet gear B	6	Sun gear B	23	Thrust plate(1.8~3.2t)
2-3	Needle bearing	8	Sun gear C	24	Cover
2-4	Gear shaft B	9	Spring washer	25	Socket head bolt
2-5	Thrust washer	10	Flange	26	Plug(PT 1/2)
2-6	Spring pin	11	Floating seal	27	Plug(PT 1/4)
3	Holder C assembly	12	Angular bearing	28	Plug(PT 1/4)
3-1	Holder	13	Housing		

## 2) TOOLS AND TIGHTENING TORQUE

### (1) Tools

Tool name	Remark	
Allen wrench	5	
	6	
	8	
	10	
	14	
Socket for socket wrench	27	
Spanner	27	
Torque wrench	Capable of tightening with the specified torques.	
Pliers	-	
( - ) Driver	6 × 100	
Hammer	Steel and plastic	
Eye bolt	M10, PT 1/2, M12, M16	

### (2) Tightening torque

Part name	Item	Size	Torque		Wrench size	
			kgf · m	lbf · ft	in	mm
Socket head bolt	35	M 16	28 ~ 32	202.5 ~ 231.5	0.55	14
	36	M 18	40 ~ 45	289.3 ~ 325.5	0.55	14
	40	M 12	12.3 ~ 13.7	89.0 ~ 99.1	0.39	10
	44	M 10	5.5 ~ 6.5	39.9 ~ 47.0	0.31	8
Plug	45	PT 1/2	4 ~ 5	28.9 ~ 36.2	0.39	10
	46	PT 1/4	1 ~ 1.5	7.2 ~ 10.8	0.24	6
	47	PT 1/8	0.9 ~ 1.0	6.5 ~ 7.2	0.20	5

### 3) DISASSEMBLY

#### (1) Preparation

- ① Drain out the oil from inside the reduction unit.
  - ② Clean the outside of the reduction unit with cleaning oil and let it dry.
- ※ Before cleaning, confirm that each port is plugged.

#### (2) Disassembling the cover

With the motor placed on its mounting surface, fix the reduction unit assembly on a stable work bench.

Loosen socket bolts(25) and remove cover(24).

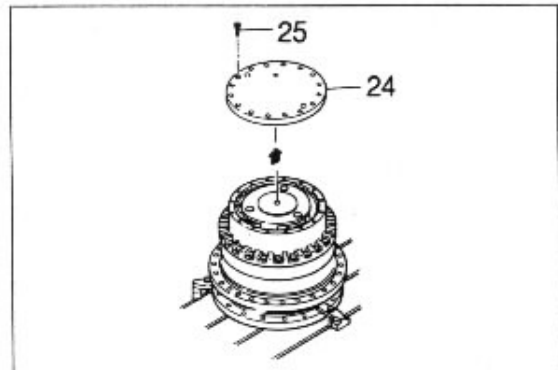

#### (3) Disassembling the gears

- ① Remove thrust plate(23). Then remove drive gear(4) and holder A assembly (1).

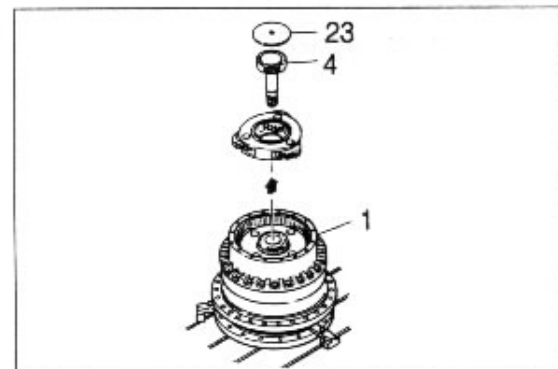

- ② Remove sun gear B(6) and holder B assembly(2).

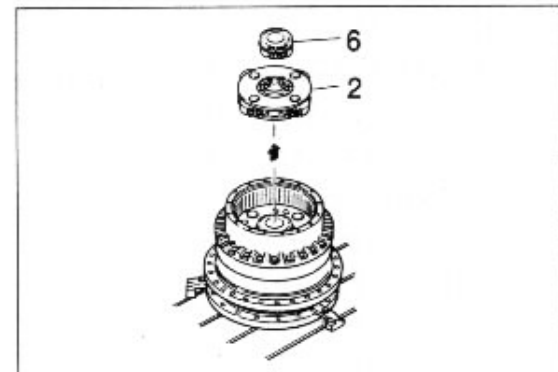

- ③ Loosen socket bolts(21) and remove ring gear(19).

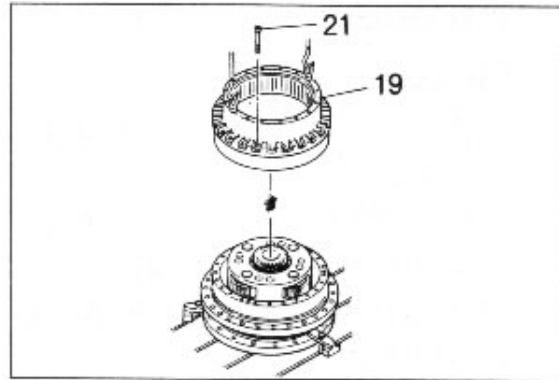

- ④ Remove sun gear C(8).

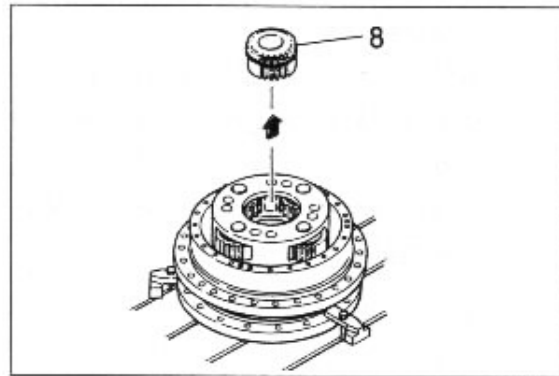

- ⑤ Loosen socket bolts(17,16)and remove holder C assembly(3).

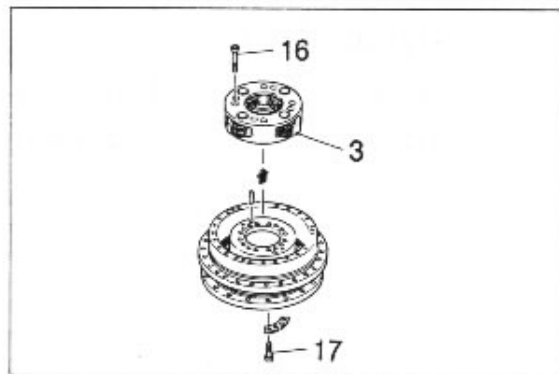

**(4) Disassembling the holders assembly**

Knock a spring pin into the gear shaft and disassemble the holder assembly.

- Holder A : Spring pin(1-6)  
Gear shaft A(1-4)
- Holder B : Spring pin(2-6)  
Gear shaft B(2-4)
- Holder C : Spring pin(3-6)  
Gear shaft B(3-4)

- ※ Exercise care so as not to knock a pin in too much.(to a depth of about 14 mm)  
A spring pin knock-in tool will be convenient for this operation.

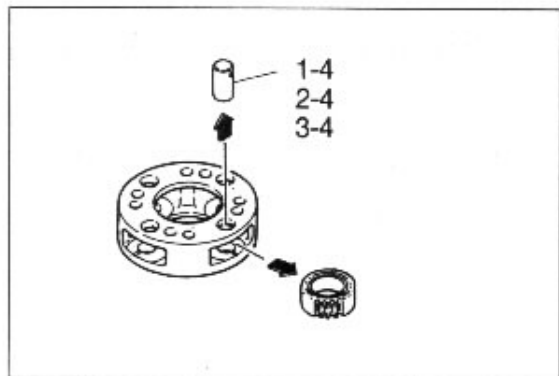

**(5) Disassembling the flange**

① Fix flange(10) and remove housing(13).

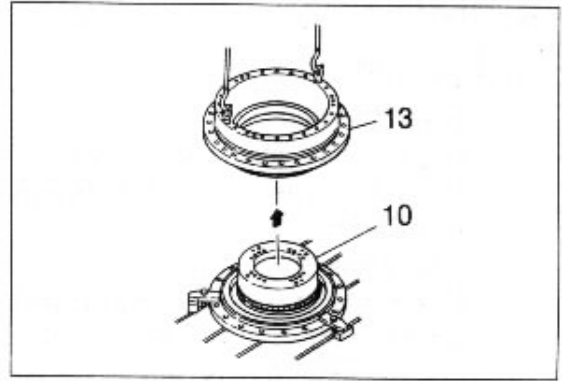

② Separate floating seal(11), angular bearing(12) and flange(10) from housing(13).

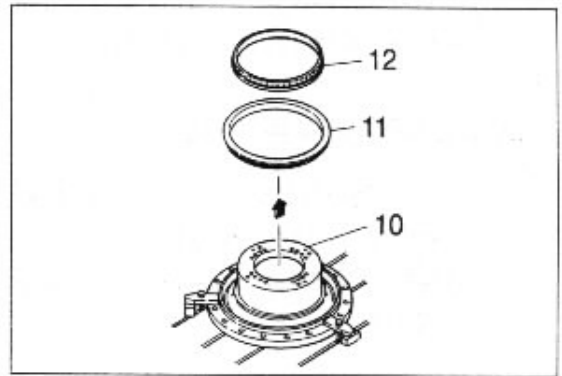

With this, disassembly is over.

## 4) ASSEMBLY

### (1) Preparation

① Inspecting parts

Inspect that each of the parts is reusable referring to "MAINTENANCE STANDARD".

② Cleaning parts

Clean the matching surface and screwed parts to be free from moisture, dirt and other foreign matter, using clean cleaning oil. Degrease parts to which loctite #515 and #242 are applied, using thinner or something.

### (2) Assembling the Housing

① Fix flange(10) and fix one end of floating seal(11) to flange(10).

※ Apply sufficient grease to floating seal(11).

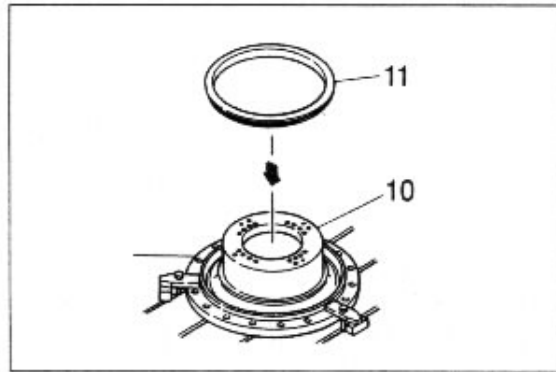

② Fix another end of floating seal(11) to flange(10) so they are aligned on the same line.

※ Apply the sealing surface with grease or gear oil.

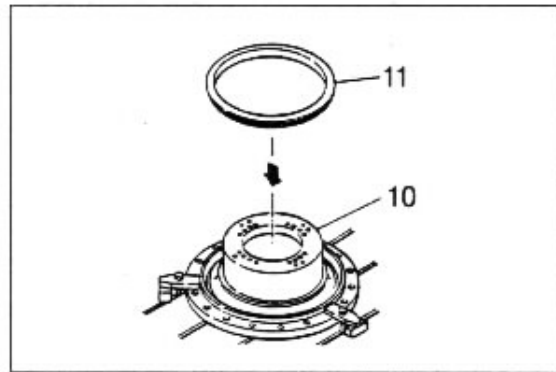

③ Fit the inner race assembly of angular bearing(12) to flange(10).

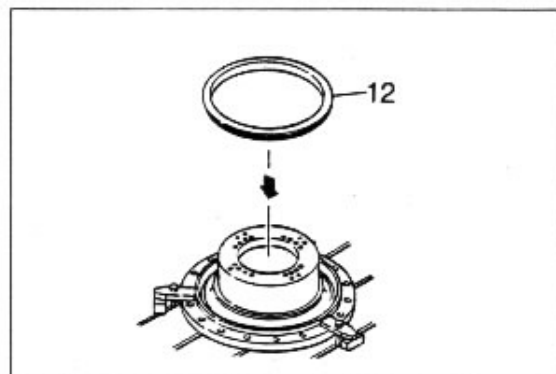



- ④ Press the outer race of angular bearing (12) into housing(13) and mount it gently onto flange(10).

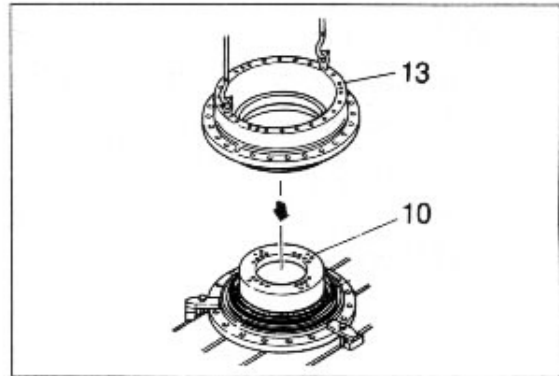

- ⑤ Fit the inner race assembly of one of the angular bearings(12) to flange(10).

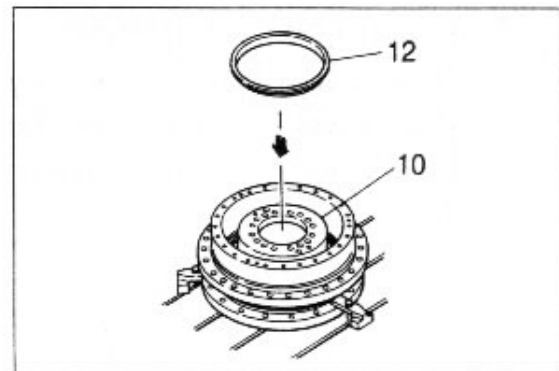

- ⑥ Press pin(13) into flange(10). At that time, adjust the height of pin(13) so it sticks 21.5~22.2 mm above the end surface of flange(10).

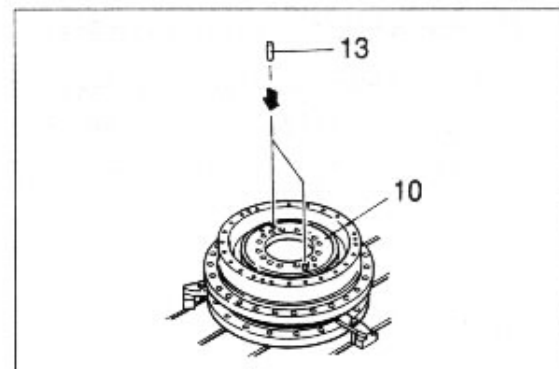

### (3) Assembling the holder C

- ① Fit the same number of shims(14) used at disassembly.

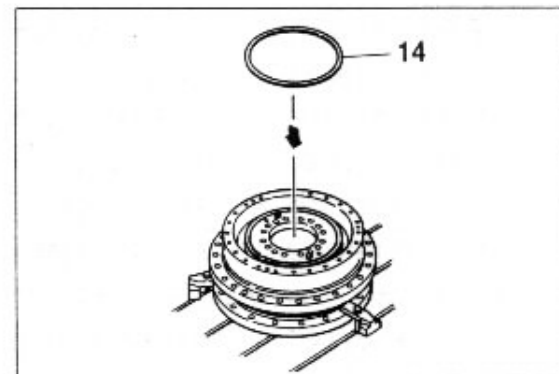

- ② Match the pin hole in holder C (3-1) to pin(15), fit holder C (3-1) to flange(10) and then tighten socket bolts(16).

Tightening torque : 40 ~45kgf · m

- ※ Apply bolt lock(equivalent to loctite #271) to socket bolts.

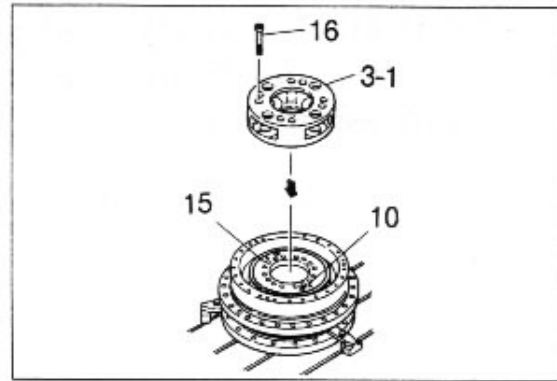

#### (4) Assembling the holder A assembly

- ① Fit needle bearing(1-3) to planetary gear(1-2) and place thrust plate(1-5) to the side face of the planetary gear(1-2).

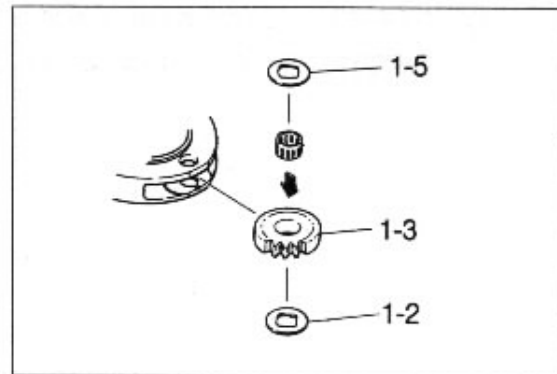

#### (5) Assembling the holder B assembly

- ① Fit needle bearing(2-3) to planetary gear(2-2) and place thrust plate(2-5) to the side face of the planetary gear(2-2).

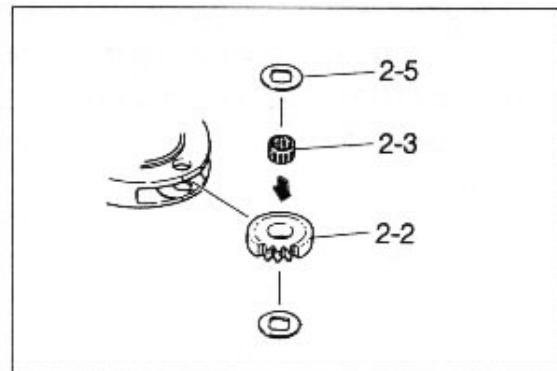

- ② Then, fit it to holder B (2-1), match hole positions and attach gear shaft(2-4).

- ※ Since the thrust washer is thin, match holes together and use care so as not to damage shaft A when inserting it.

- ※ Insert gear shaft B (2-4) by matching the spring hole of the gear shaft with the spring pin hole of holder B. Confirm that planetary gear A turns smoothly.

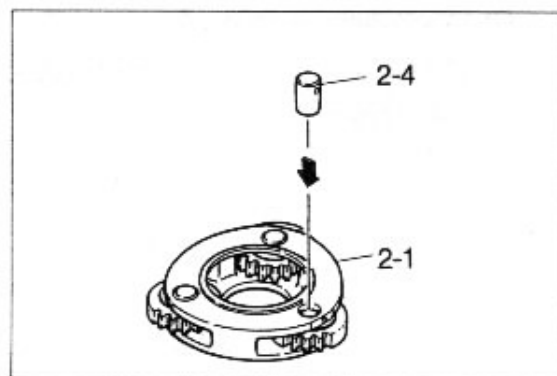

- ③ Knock spring pin(2-6) till it sinks below the outer perimeter of holder B(2-1), and then caulk four diagonally opposite positions.

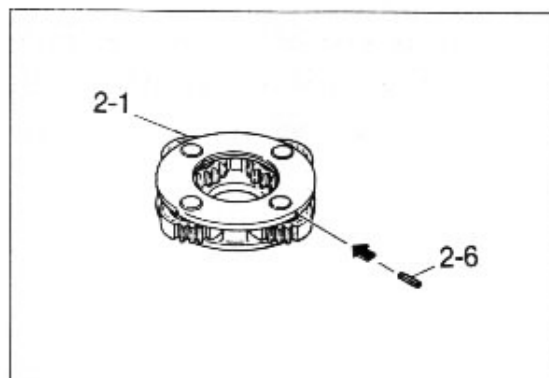

#### (6) Assembling the holder C assembly

- ① Apply grease to the inner surface of planetary gear C put it under thrust washer(3-7) and fit the floating bushing (3-5). Apply grease to eighteen bar-shape rollers(3-3) and assemble it.

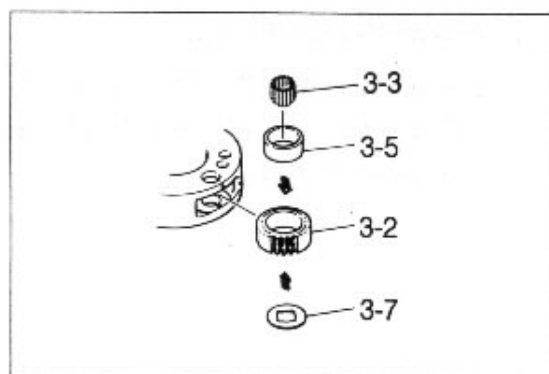

- ② Mount thrust washer(3-7) to the top, fix it to holder C(3-1) and match it to the hole of gear shaft(3-4).

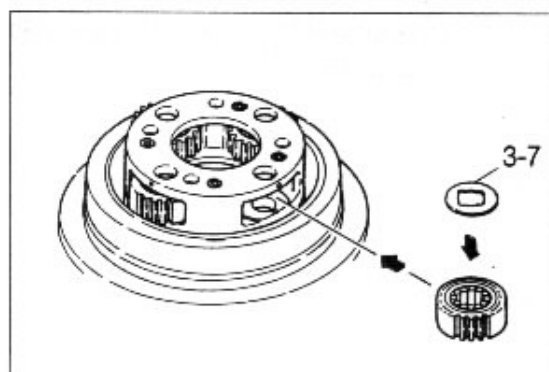

- ③ Match the spring pin hole of gear shaft C to the spring hole of holder C and insert gear shaft C (3-4) into holder C(3-1).

※ Confirm that planetary gear C(3-2) turns smoothly.

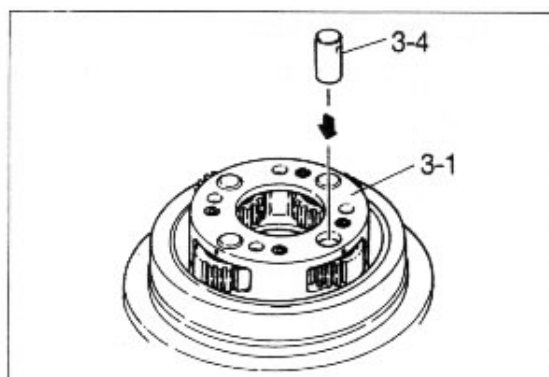

- ④ Knock spring pin (3-8) till it sinks below the outer perimeter of holder C and caulk four diagonally opposite positions.

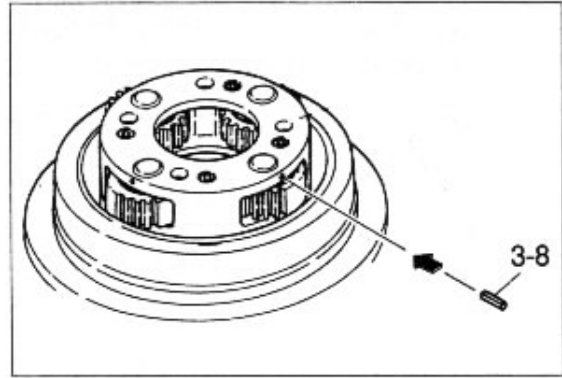

### (7) Assembling the ring gear

- ① Knock three pins (22) into housing (13).  
※ Adjust so pin (22) sticks 22~22.5 mm above housing(13).

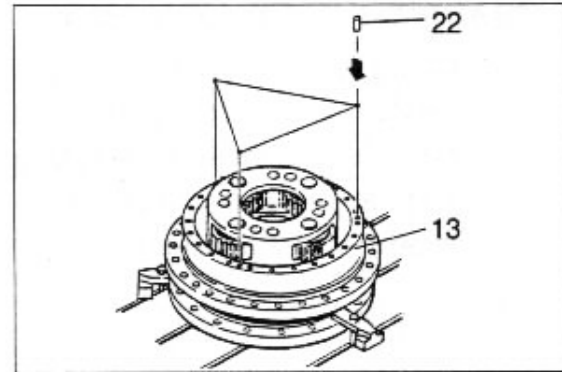

- ② Apply grease to O-ring (30) and fit it to housing (13).

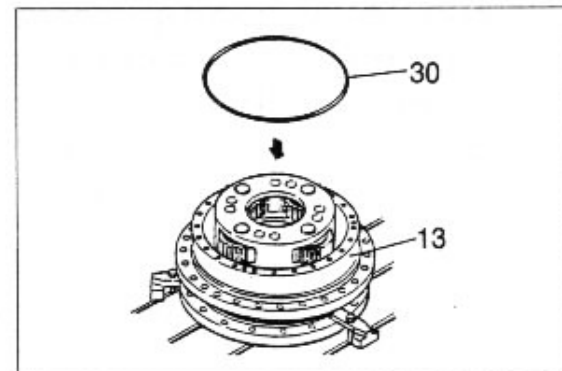

- ③ Fit ring gear (19) to housing (13) and fasten them together with socket bolts (21).

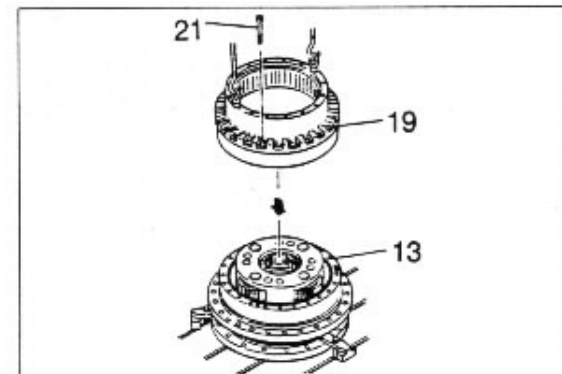

- (8) Attach sun gear C(8), holder B assembly (2) and sun gear B(6) in that order.

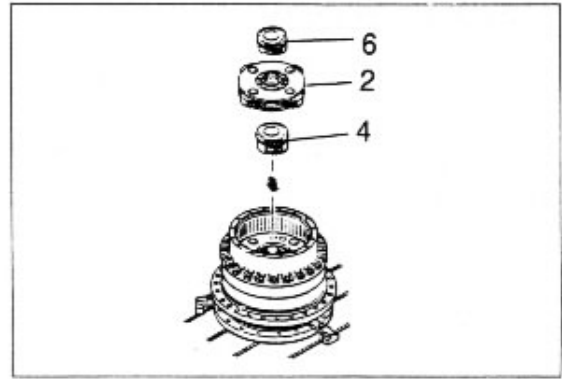

- (9) Apply grease to thrust plate (5) and fit it to holder A assembly (1).

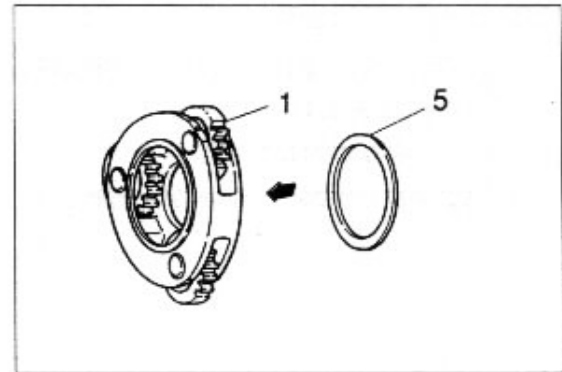

- (10) Fit holder A assembly (1).

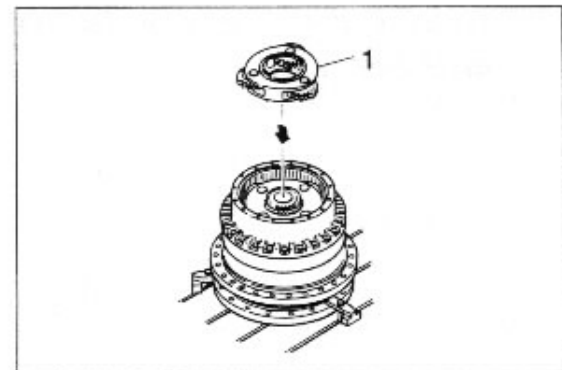

- (11) Fit drive gear (4).

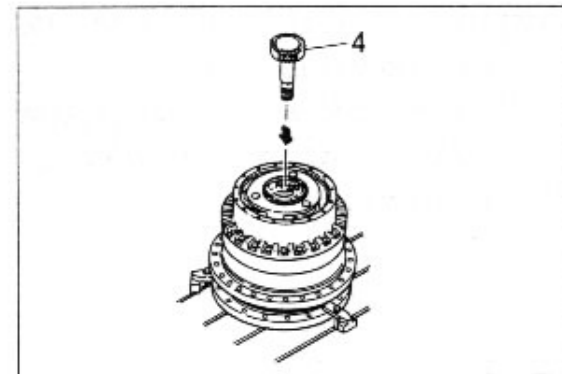

(12) Attach thrust plate (23).

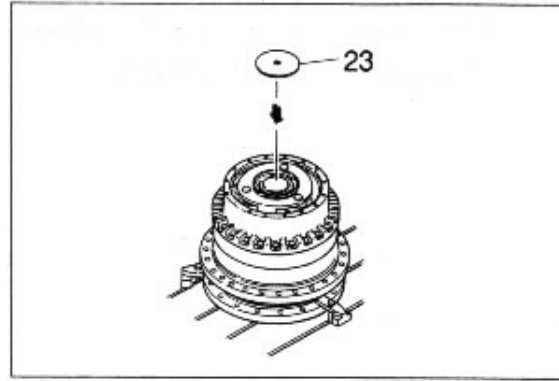

(13) Apply liquid packing three-bond #1211 evenly to the spigot joining of cover (24), fix the cover to ring gear (19) and fasten them with socket bolts (25).

※ Degrease the matching areas clean.

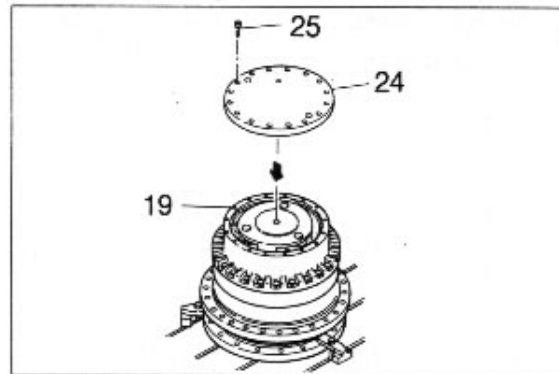

(14) Place seal tape around plugs (26) and tighten them up.

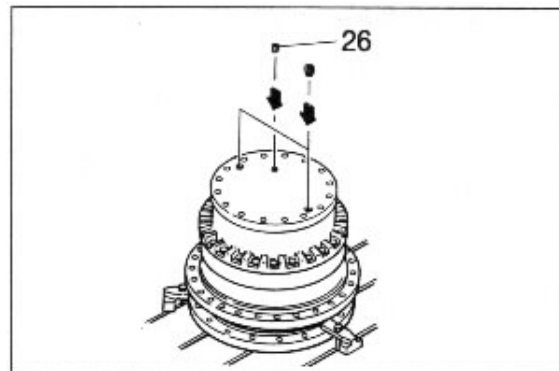

(15) Turn over the reduction unit, attach plate (18) and tighten socket bolts (17).

※ Degrease socket bolts and female threads sufficiently and coat socket bolts (17) with loctite #271.

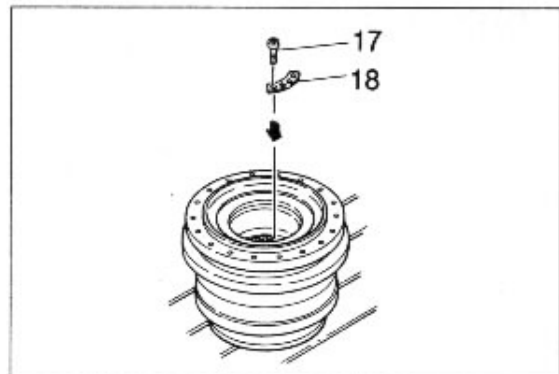

- (16) Place seal tape around plug (27) and tighten it to housing (13).

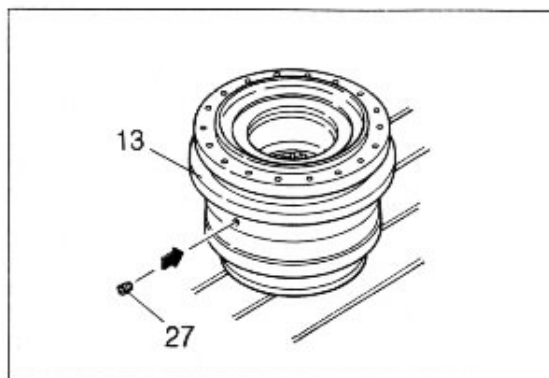

- (17) Do not forget to fill lube oil.  
Quantity : 4.4 l

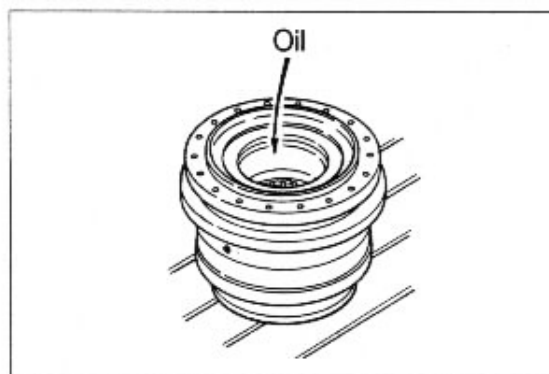

This completes assembly.