

GROUP 5 COMBINED OPERATION

1. OUTLINE

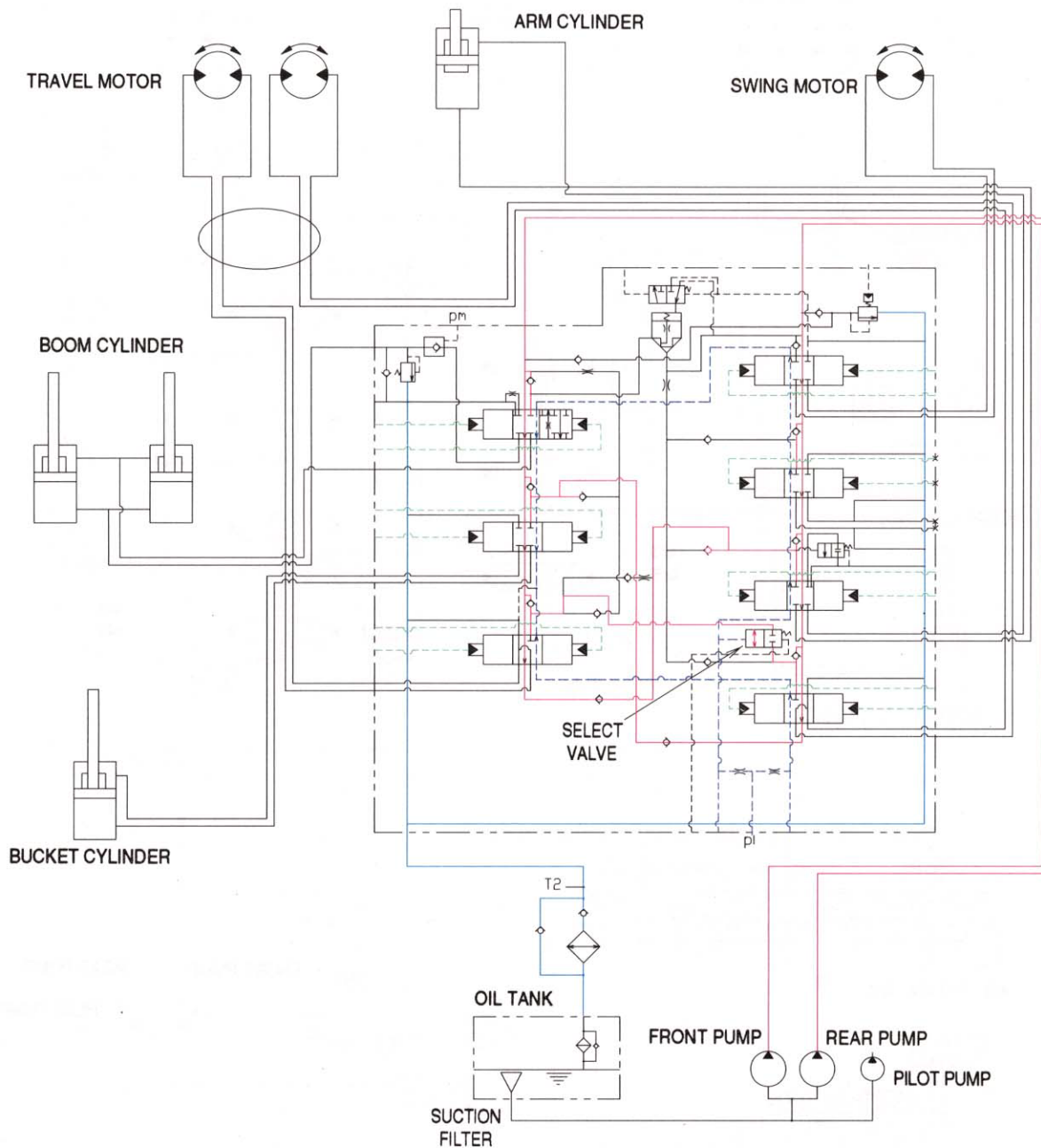

In case operation, the oil flows from both main pumps through the neutral oil passage, bypass oil passage and confluence oil passage. Then the oil is supplied to each actuator and function them. Check valves and orifices are provided with on these flow passage. These control the oil flows from the pump corresponding to the each actuator's state of functioning and smooth the combined operation.

SELECT VALVE

This select valve is provided in the control valve.

When the spool except travel is moved, the pilot oil from the pilot pump is closed by its spool. Consequently, the pilot pressure port of the select valve rises and its spool is moved. Then the left and right travel oil supply passage is opened, and the machine straight travelling.

2. COMBINED SWING AND BOOM OPERATION

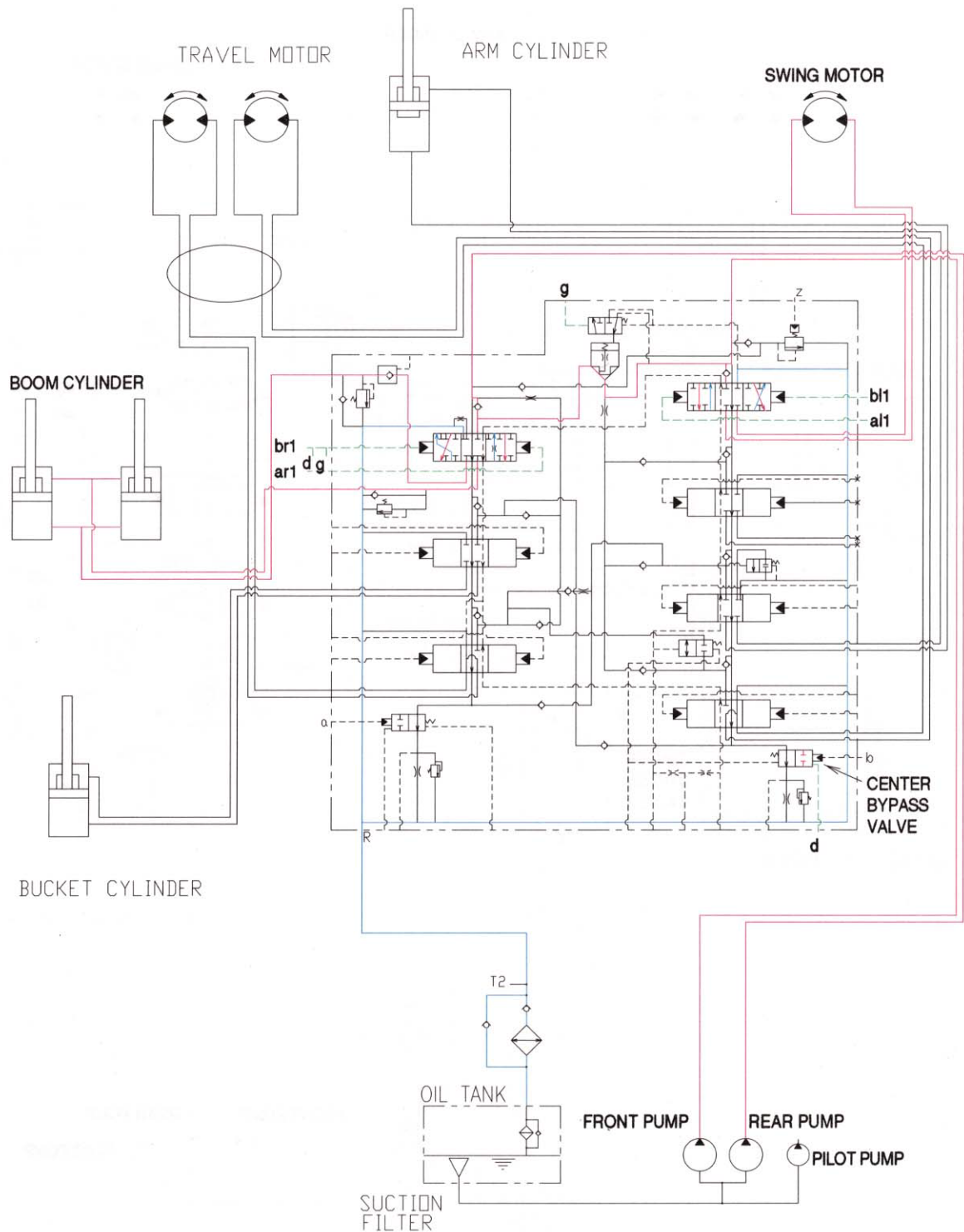

When the swing and boom functions are operated, simultaneously the swing spool and boom spools changed. The oil flows from the rear pump through boom section of the control valve to boom cylinders and the boom functions.

The oil flows from front pump through swing section to swing motor. At the same time the pressure in the boom circuits can be high while the swing pressure is low therefore the oil flows from front pump to boom cylinders through boom confluence passage.

3. COMBINED SWING AND ARM OPERATION

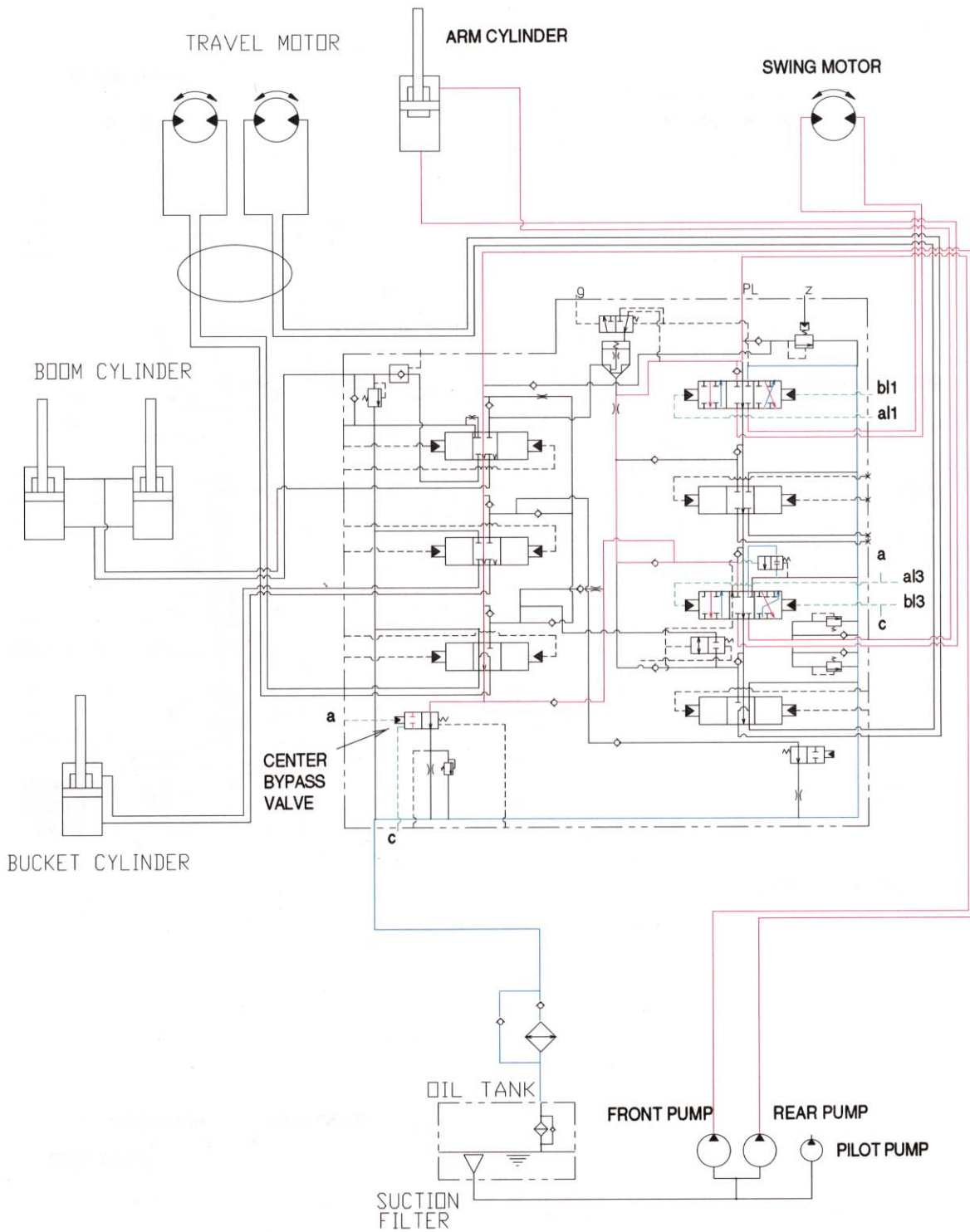

When the swing and arm functions are operated, simultaneously the swing and arm spools changed.

The oil flows from the front pump through arm and swing section of the control valve to arm cylinder and swing motor, and the arm and swing function.

At the same time, the center bypass valve is blocked, the oil flows from the rear pump through the arm confluence oil passage to arm cylinder.

4. COMBINED SWING AND BUCKET OPERATION

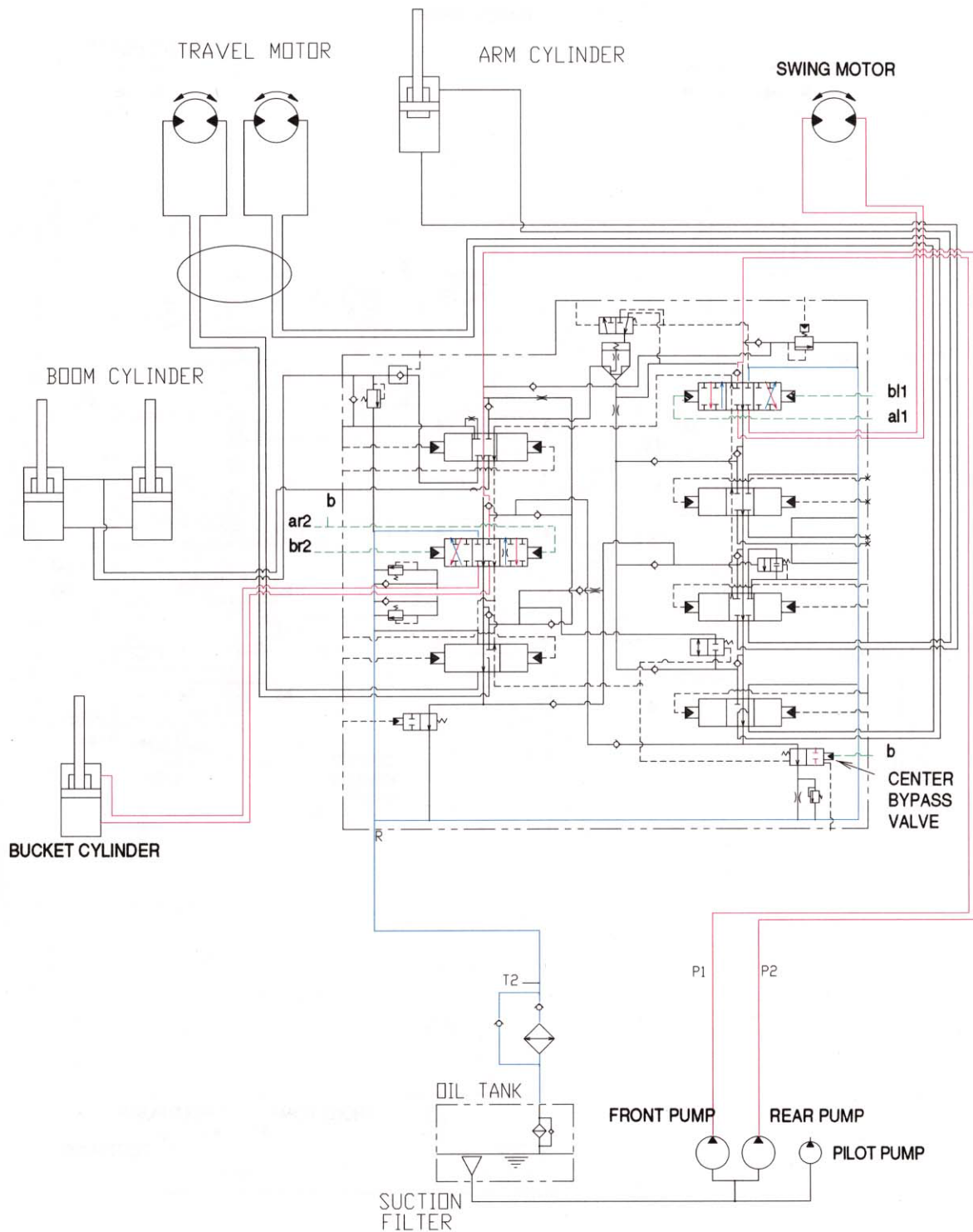

When the swing and bucket functions are operated, the swing and bucket spools changed. The oil flows from rear pump through the bucket section of the left control valve to the bucket cylinder and the bucket function. The oil flows from front pump through swing section of the right control valve to the swing motor and swing the superstructure.

5. COMBINED SWING, BOOM, ARM AND BUCKET OPERATION

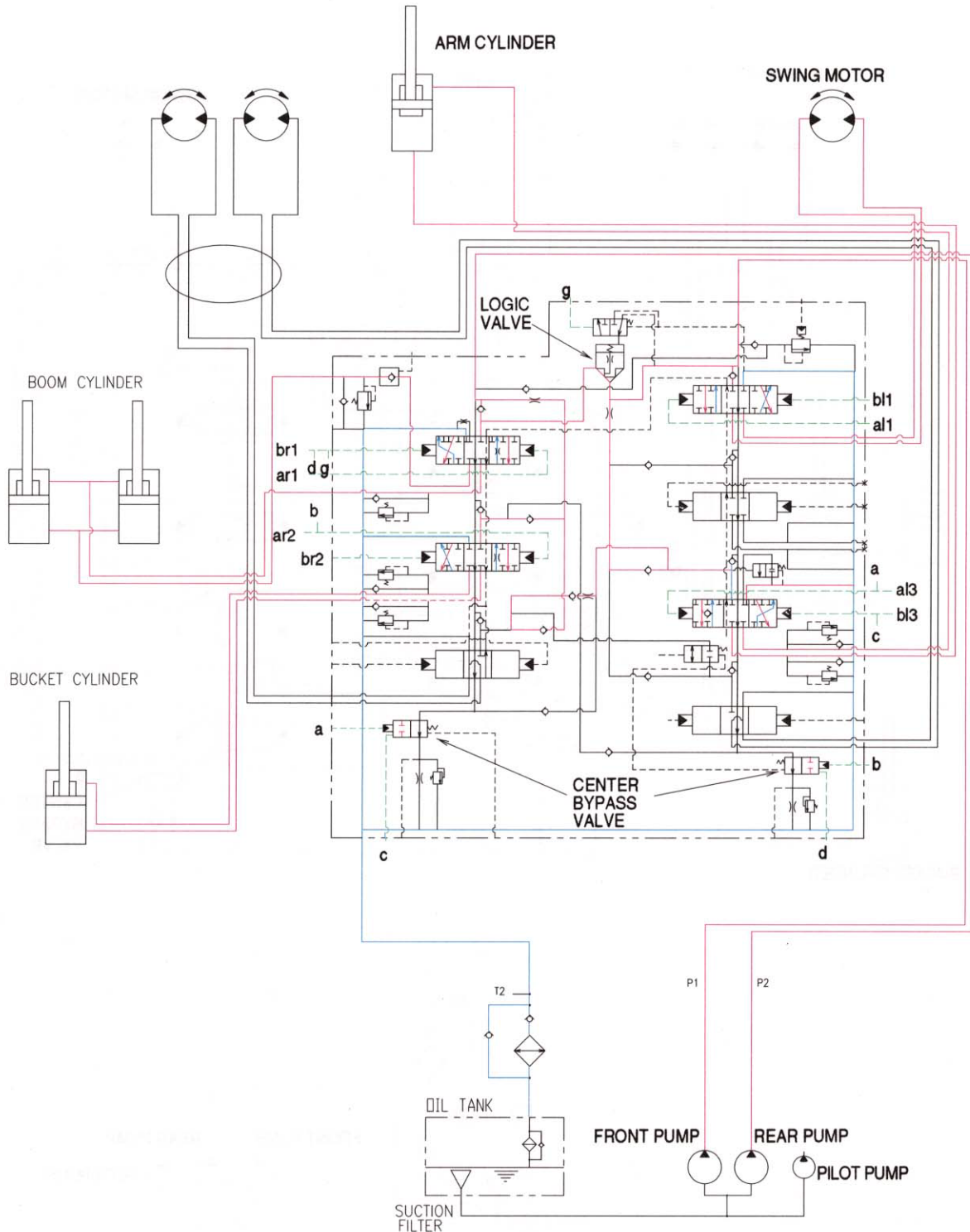

When the swing, boom, arm and bucket functions are operated, the each spools of the control valve changed.

The oil flows from rear pump through boom and bucket section to boom and bucket cylinders.

The oil flows from front pump through the parallel oil passage and the swing and arm section to swing motor and arm cylinder. Then the functions to each actuators.

According to the state of each actuators functioning, both center bypass valve is blocked, the oil flows from rear pump through the confluence oil passage to right control valve and the oil flows from front pump through logic valve to boom cylinders.

6. COMBINED SWING AND TRAVEL OPERATION

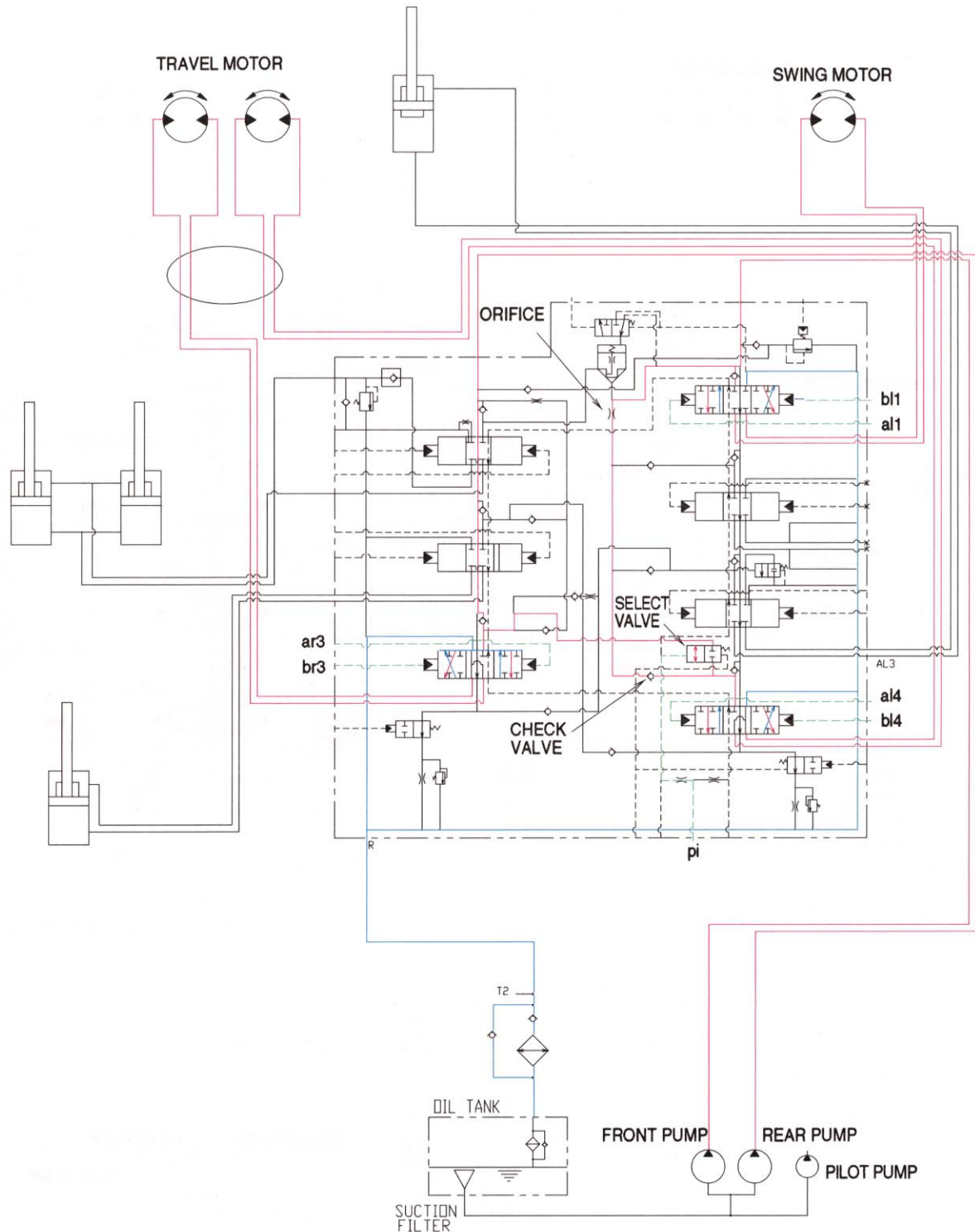

When the swing and right and left travel functions are operated, the swing and travel(R),(L) spools and the select valve changed. The oil flows from rear pump through the travel (R),(L) section of the control valve to the right and left travel motor.

And the oil flows from front pump through swing section of the right control valve to the swing motor. Because of check valve the pressure in the travel circuit can be high while the swing pressure is low. When the travel circuit pressure drops lower than swing pressure, as when traveling downhill, swing priority and smoothness are maintained because of the orifice. In either case, the machine will continue to travel straight.

7. COMBINED BOOM AND TRAVEL OPERATION

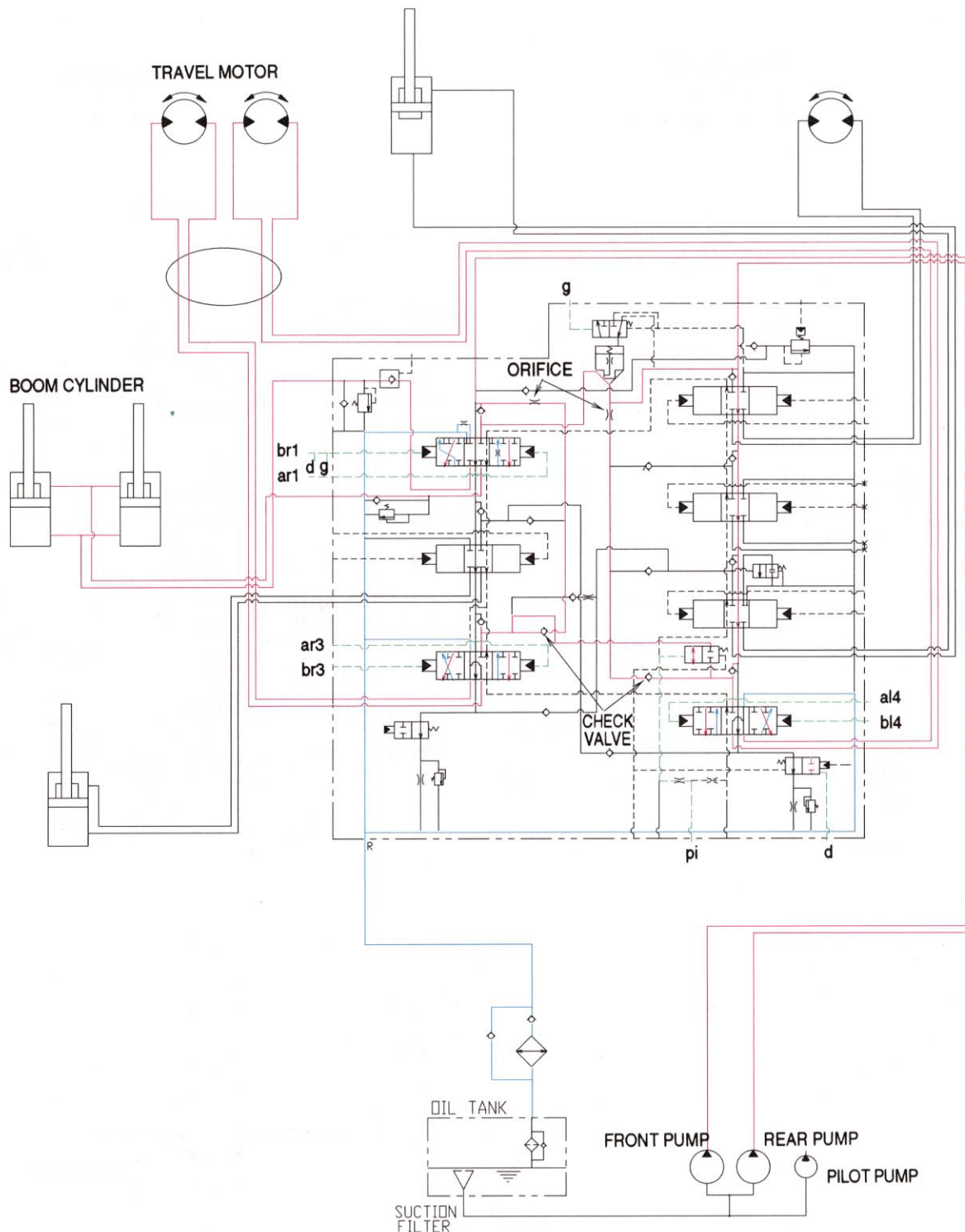

When the boom and travel (R) (L) functions are operated, the boom and travel (R),(L) spools and the select valve changed. The oil flows from front pump through the travel (R),(L) section of the control valve to the right and left travel motor.

And the oil flows from rear pump through boom section of the left control valve to the boom cylinder.

Because of check valve the pressure in the travel circuit can be high while the boom pressure is low.

When the travel circuit pressure drops lower than boom pressure, as when travelling downhill, boom priority and smoothness are maintained because of the orifice. In either case, the machine will continue to travel straight.

8. COMBINED ARM AND TRAVEL OPERATION

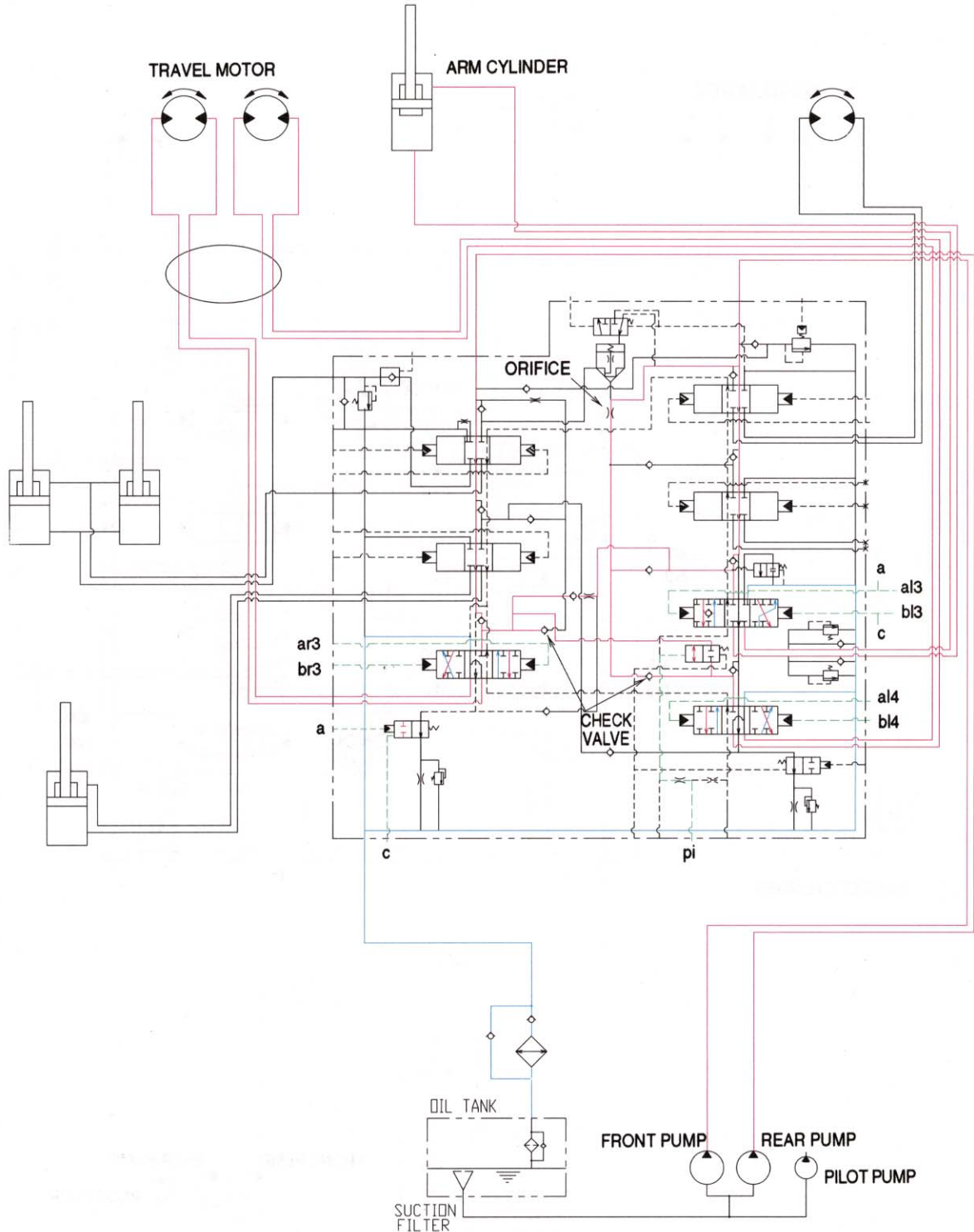

When the arm and travel (R) (L) functions are operated, the arm and travel (R),(L) spools and the select valve changed. The oil flows from rear pump through the travel (R),(L) section of the control valve to the right and left travel motor.

And the oil flows from front pump through arm section of the right control valve to the arm cylinder.

Because of check valve the pressure in the travel circuit can be high while the arm pressure is low. When the travel circuit pressure drops lower than arm pressure, as when traveling downhill, arm priority and smoothness are maintained because of the orifice. In either case, the machine will continue to travel straight.

9. COMBINED BUCKET AND TRAVEL OPERATION

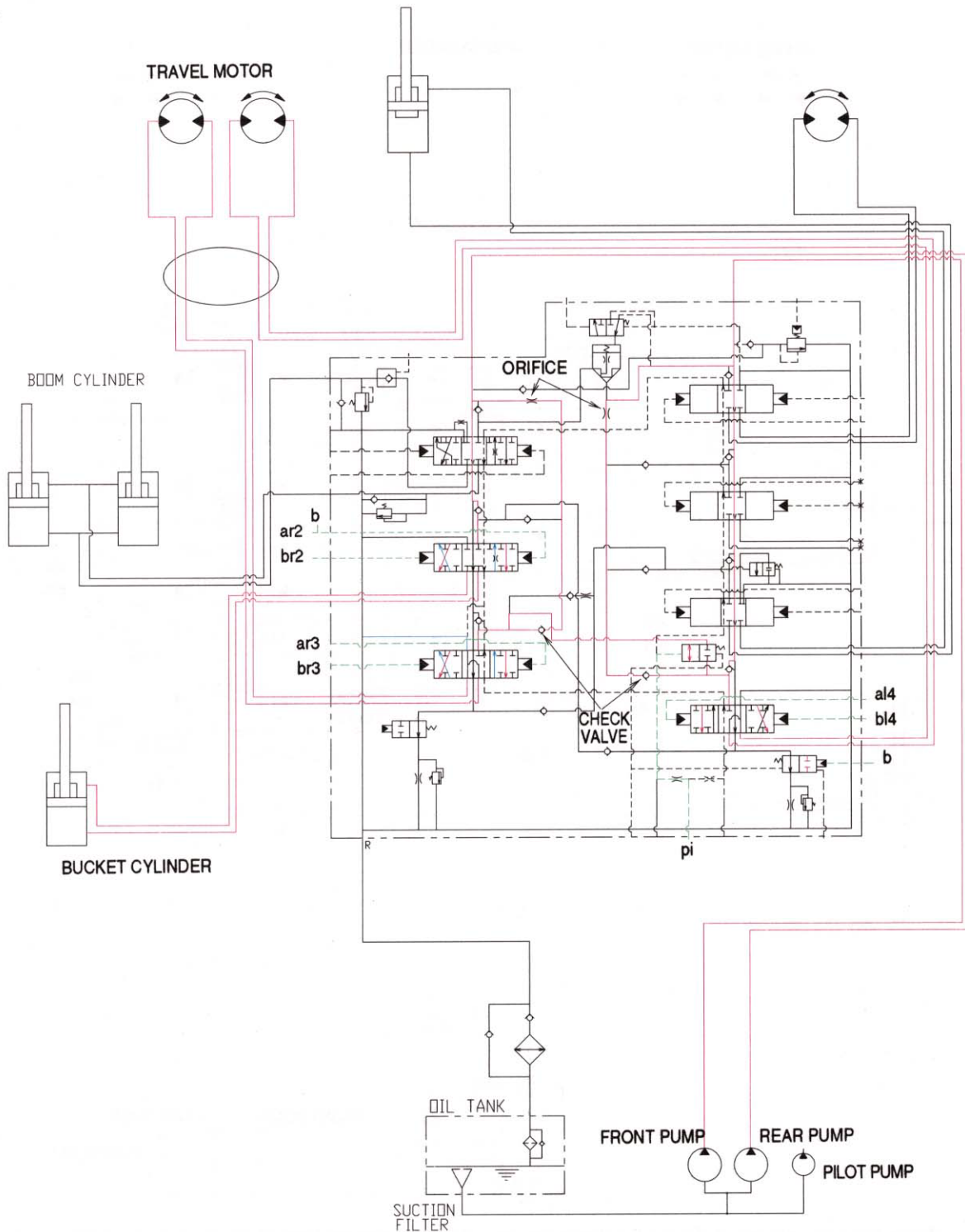

When the bucket and travel (R),(L) functions are operated, the bucket and travel (R),(L) spools and the select valve changed. The oil flows from front pump through the travel (R),(L) section of the control valve to right and left travel motor and the machine travelling.

The oil flows from rear pump through bucket section of the control valve to the bucket cylinder and the bucket functions.