

SECTION 3 HYDRAULIC SYSTEM

Group 1 Hydraulic Circuit	3-1
Group 2 Main Circuit	3-2
Group 3 Pilot Circuit	3-5
Group 4 Single Operation	3-11
Group 5 Combined Operation	3-21

SECTION 3 HYDRAULIC SYSTEM

GROUP 1 HYDRAULIC CIRCUIT

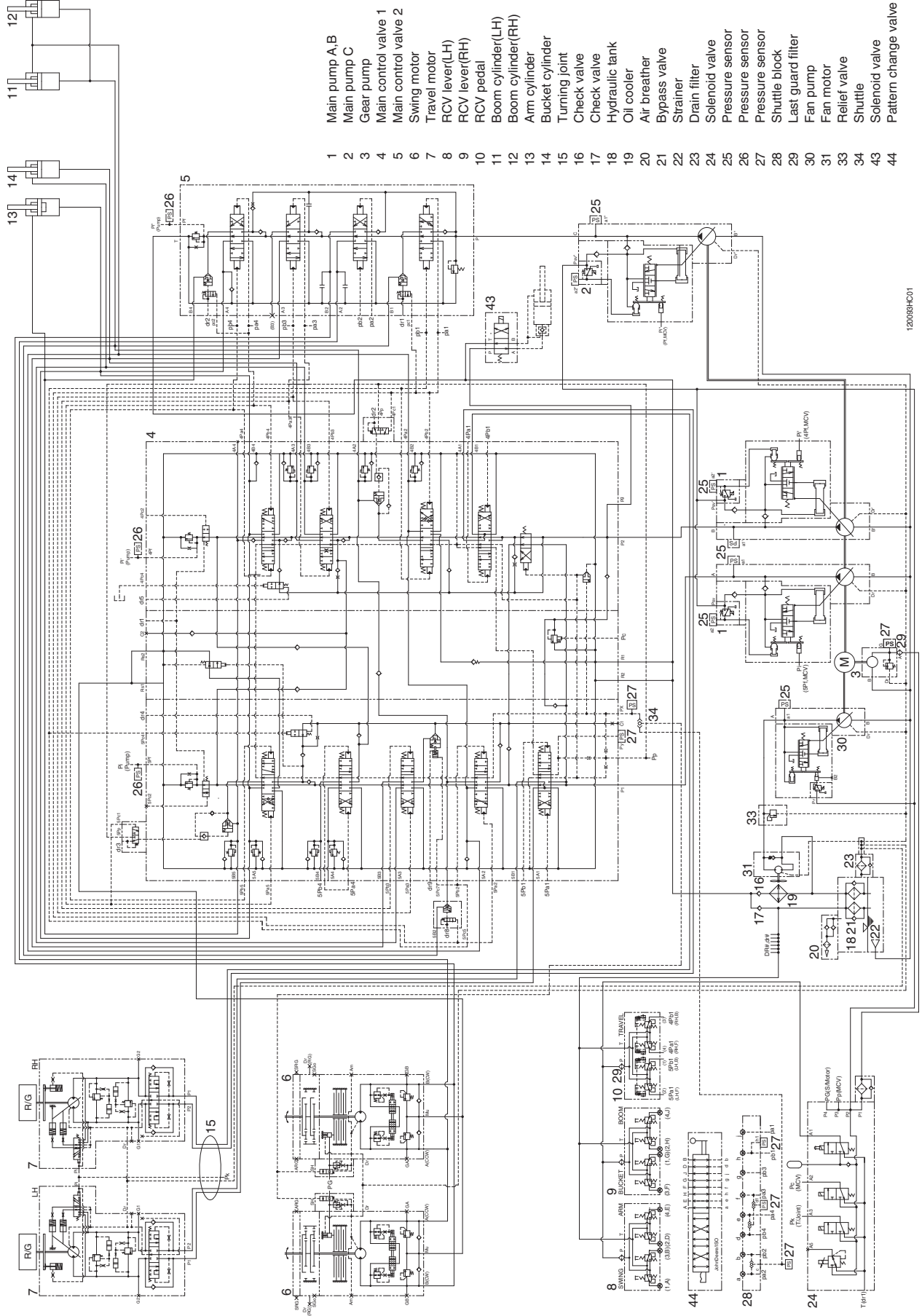

120095HC01

GROUP 2 MAIN CIRCUIT

The main hydraulic circuit consists of suction circuit, delivery circuit, return circuit and drain circuit.

The hydraulic system consists of three main pumps, two control valves, two swing motors, four cylinders and two travel motors.

The swash plate type variable displacement axial piston pump is used as the main pump and is driven by the engine at ratio 1.0 of engine speed.

1. SUCTION AND DELIVERY CIRCUIT

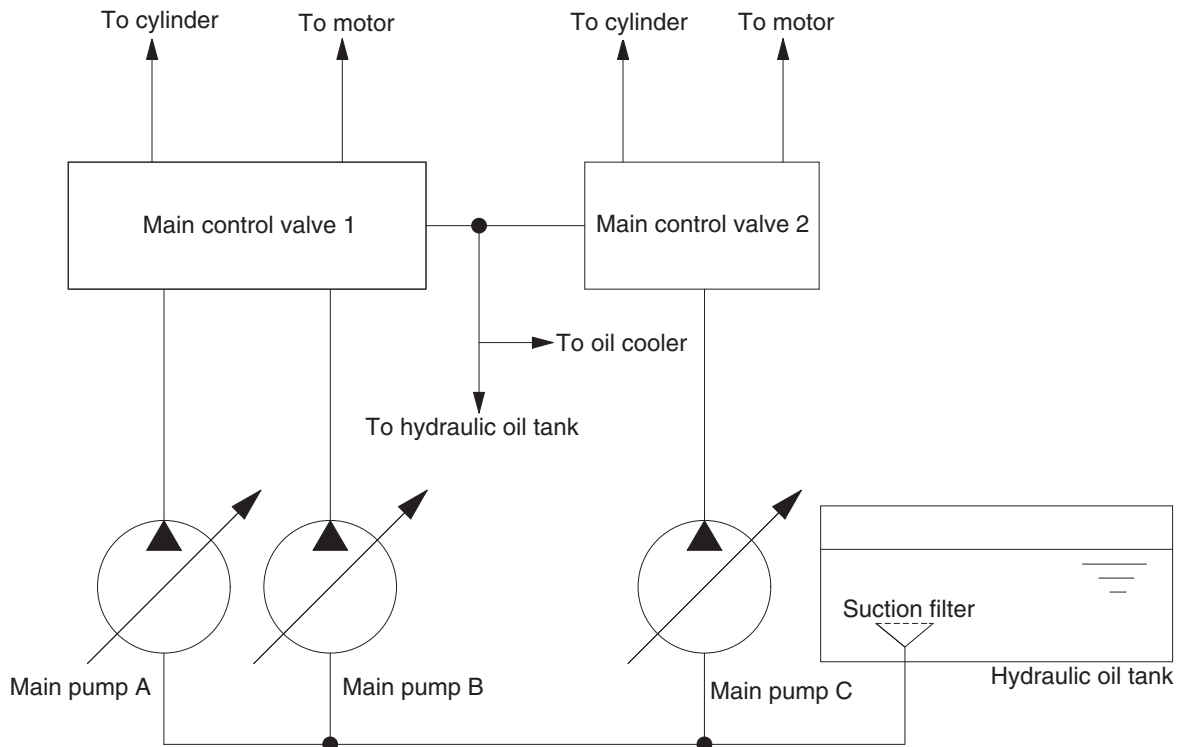

120093HC30

The pumps receive oil from the hydraulic tank through a suction filter. The discharged oil from the pump flows into the control valve and goes out the tank ports.

The oil discharged from the main pump flows to the actuators through the control valves.

The control valves control the hydraulic functions.

The return oil from the actuators flows to the hydraulic tank through the control valves and the oil cooler.

2. RETURN CIRCUIT

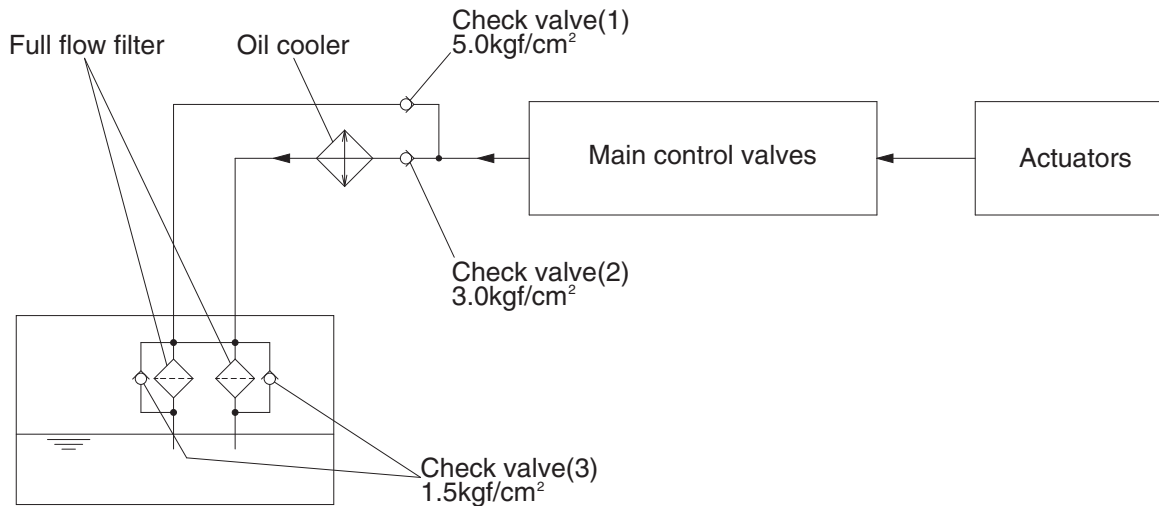

120093HC31

All oil from each actuator returns to the hydraulic tank through the control valves.

The bypass check valves are provided in the return circuit.

The setting pressure of bypass check valves are 1.5 kgf/cm² (21psi) and 5.0 kgf/cm² (71psi).

Usually, oil returns to the hydraulic tank from the left side of control valves through oil cooler.

When oil temperature is low, viscosity becomes higher and flow resistance increases when passing through the oil cooler. The oil pressure exceeds 5.0 kgf/cm² (71psi), the oil returns directly to the hydraulic tank, resulting in the oil temperature being raised quickly at an appropriate level.

When the oil cooler is clogged, the oil returns directly to the hydraulic tank through bypass check valve (1).

The full-flow filter and bypass relief valve are provided in the hydraulic tank.

The oil from control valves is combined and filtered by the return filter. A bypass relief valve is provided in the full-flow filter.

When the filter element is clogged, the bypass relief valve opens at 1.5 kgf/cm² (21psi) differential pressure.

3. DRAIN CIRCUIT

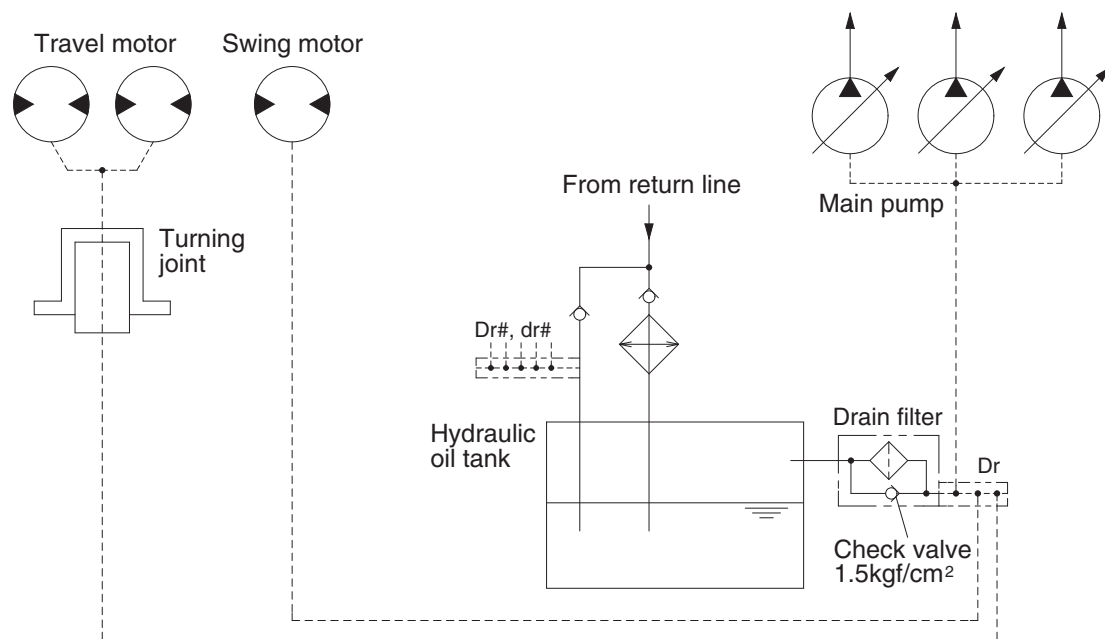

120093HC32

Besides internal leaks from the motors and main pumps, the oil for lubrication circulates. These oil have to be fed to the hydraulic tank passing through drain filter and full flow filter in the hydraulic tank. When the drain oil pressure exceed 1.5 kgf/cm² (21psi), the oil returns to the hydraulic tank directly.

1) TRAVEL MOTOR DRAIN CIRCUIT

Oil leaking from the right and left travel motors comes out of the drain ports provided in the respective motor casing and join with each other. These oils pass through the turning joint and return to the hydraulic tank after being filtered by full flow filter in the hydraulic tank.

2) SWING MOTOR DRAIN CIRCUIT

Oil leaking from the swing motors come out and return to the hydraulic tank passing through a drain filter.

3) MAIN PUMP DRAIN CIRCUIT

Oil leaking from main pumps come out and return to the hydraulic tank passing through drain filter.

GROUP 3 PILOT CIRCUIT

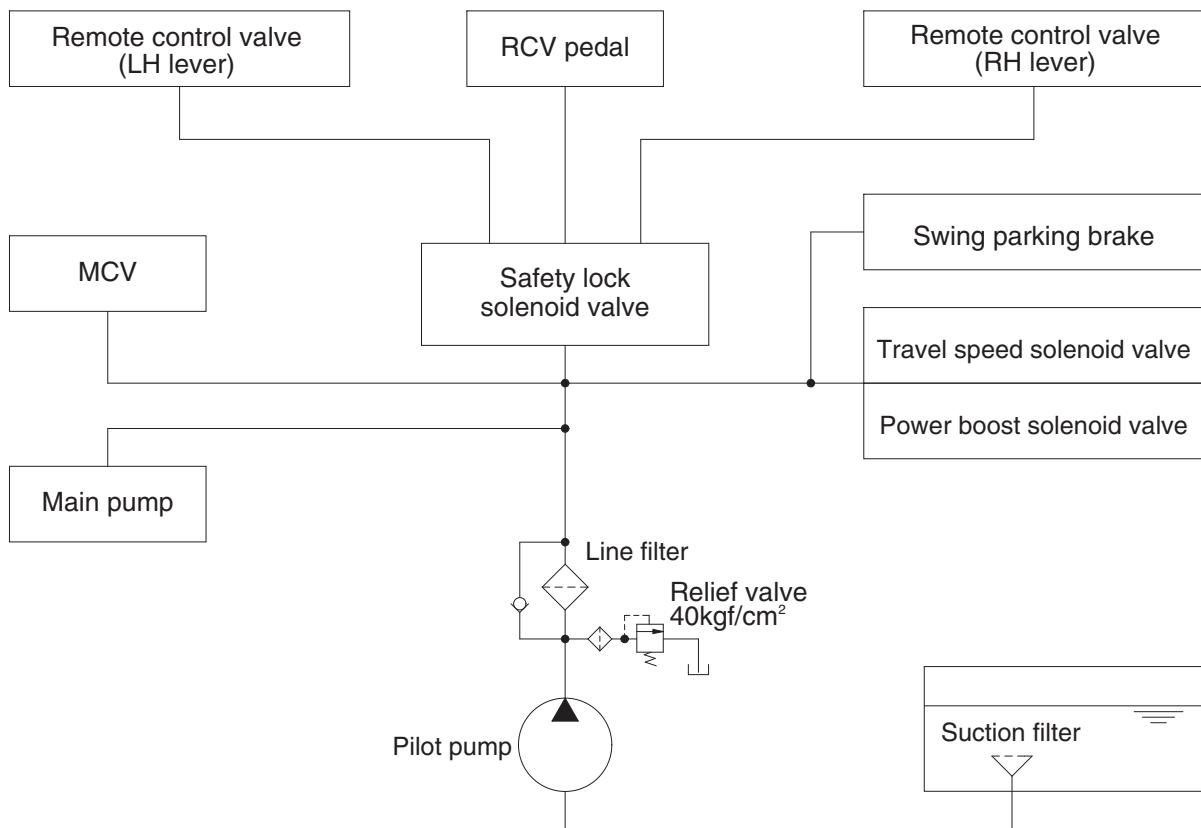

120093CI01

The pilot circuit consists of suction circuit, delivery circuit and return circuit.

The pilot pump is provided with relief valve, receives the oil from the hydraulic tank through the suction filter.

The discharged oil from the pilot pump flows to the remote control valve through line filter, EPPR valve, solenoid valve assemblies, swing parking brake, main control valve and safety lock solenoid valve.

1. SUCTION, DELIVERY AND RETURN CIRCUIT

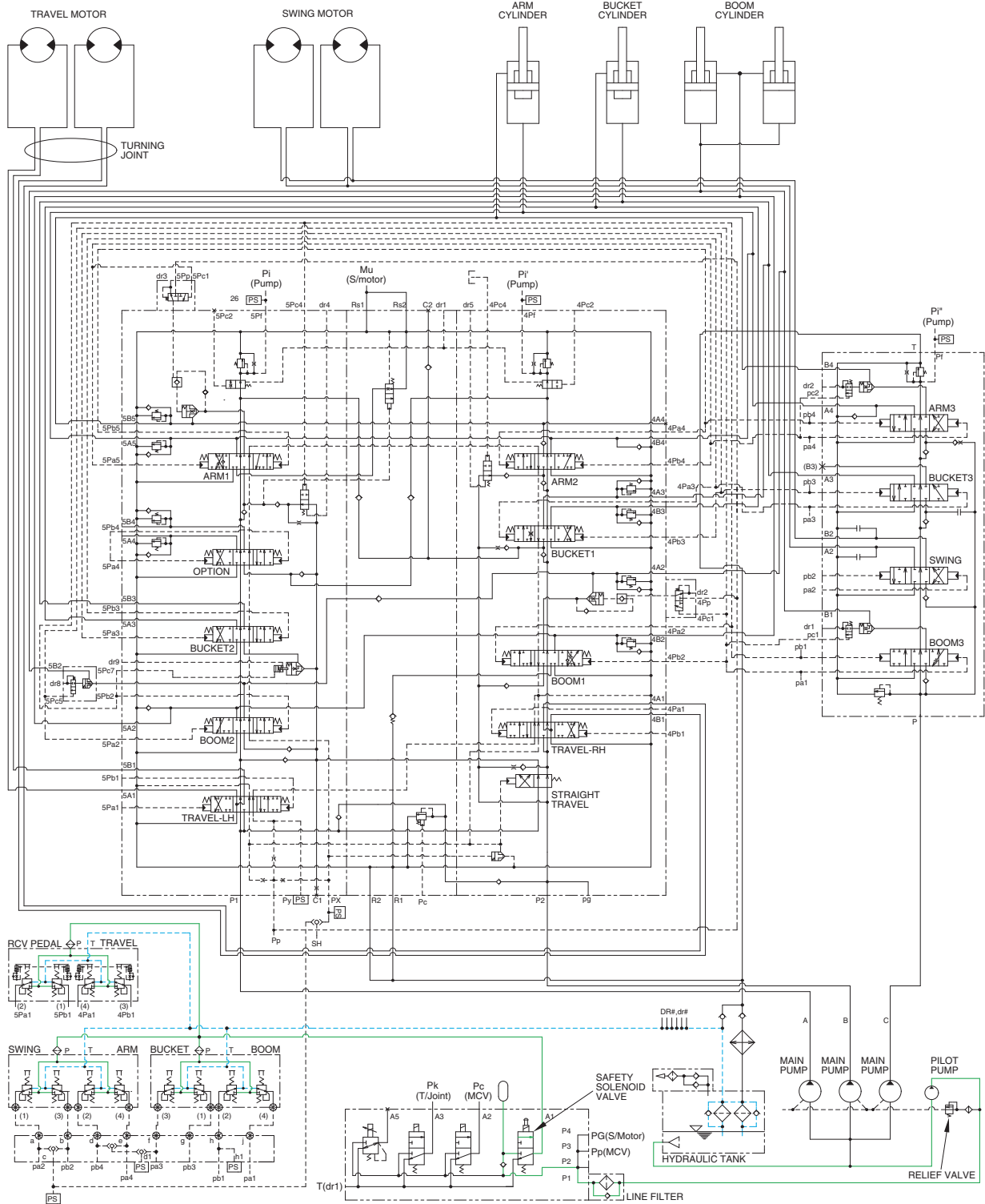

120093HC02

The pilot pump receive oil from the hydraulic tank. The discharged oil from the pilot pump flows to the safety solenoid valve through the line filter. The oil is filtered by the line filter. The pilot relief valve is provided in the pilot pump for limiting the pilot circuit pressure.

The oil filtered by line filter flows remote control valve through safety solenoid valve.

The return oil from remote control valve returned to hydraulic tank.

2. SAFETY SOLENOID VALVE (SAFETY LEVER)

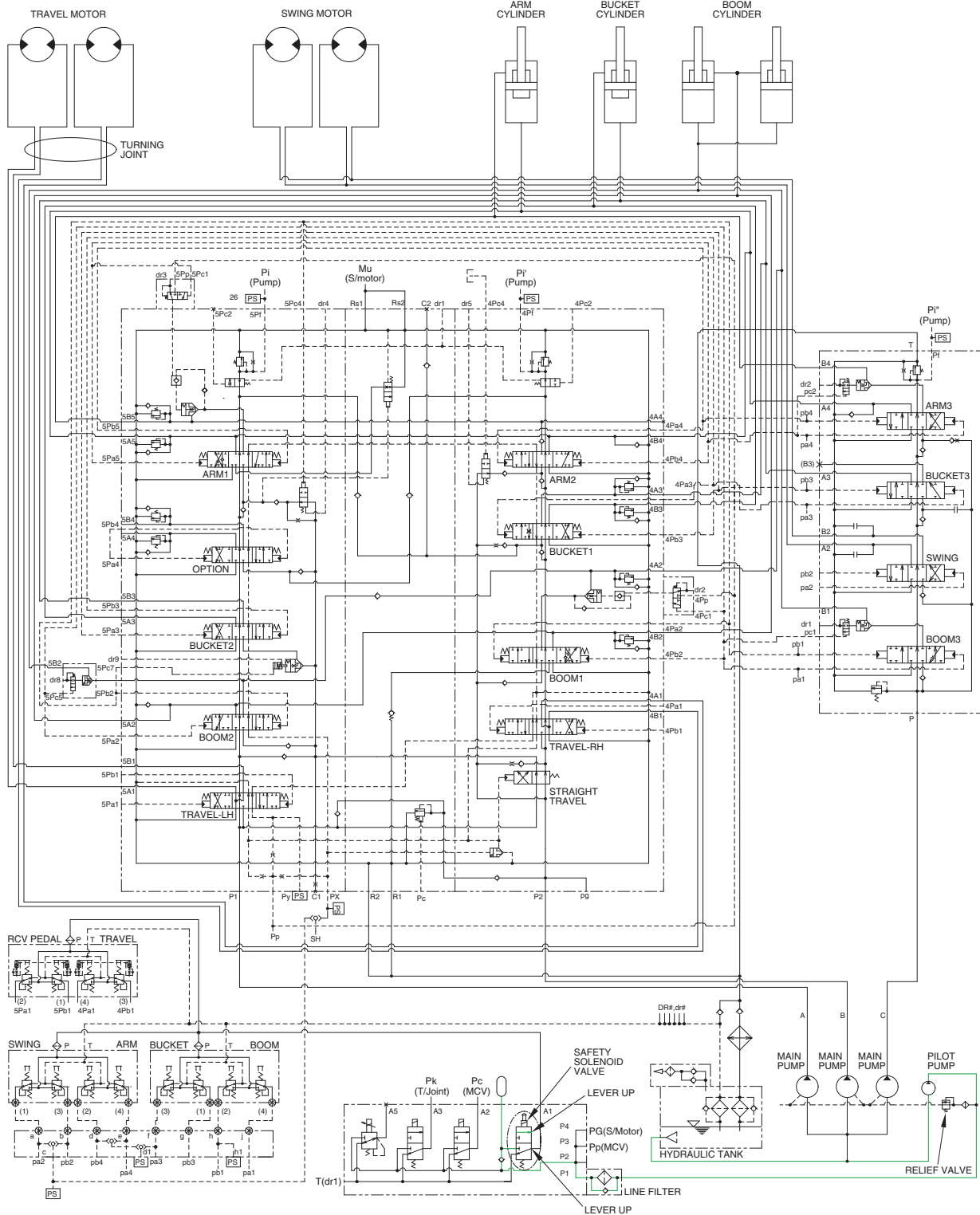

120093HC03

When the lever of the safety solenoid valve is moved downward, oil flows into the remote control valve through solenoid valve and line filter.

When the lever of the safety solenoid valve moved upward, oil does not flows into the remote control valve, because of blocked by the spool.

3. TRAVEL SPEED CONTROL SYSTEM

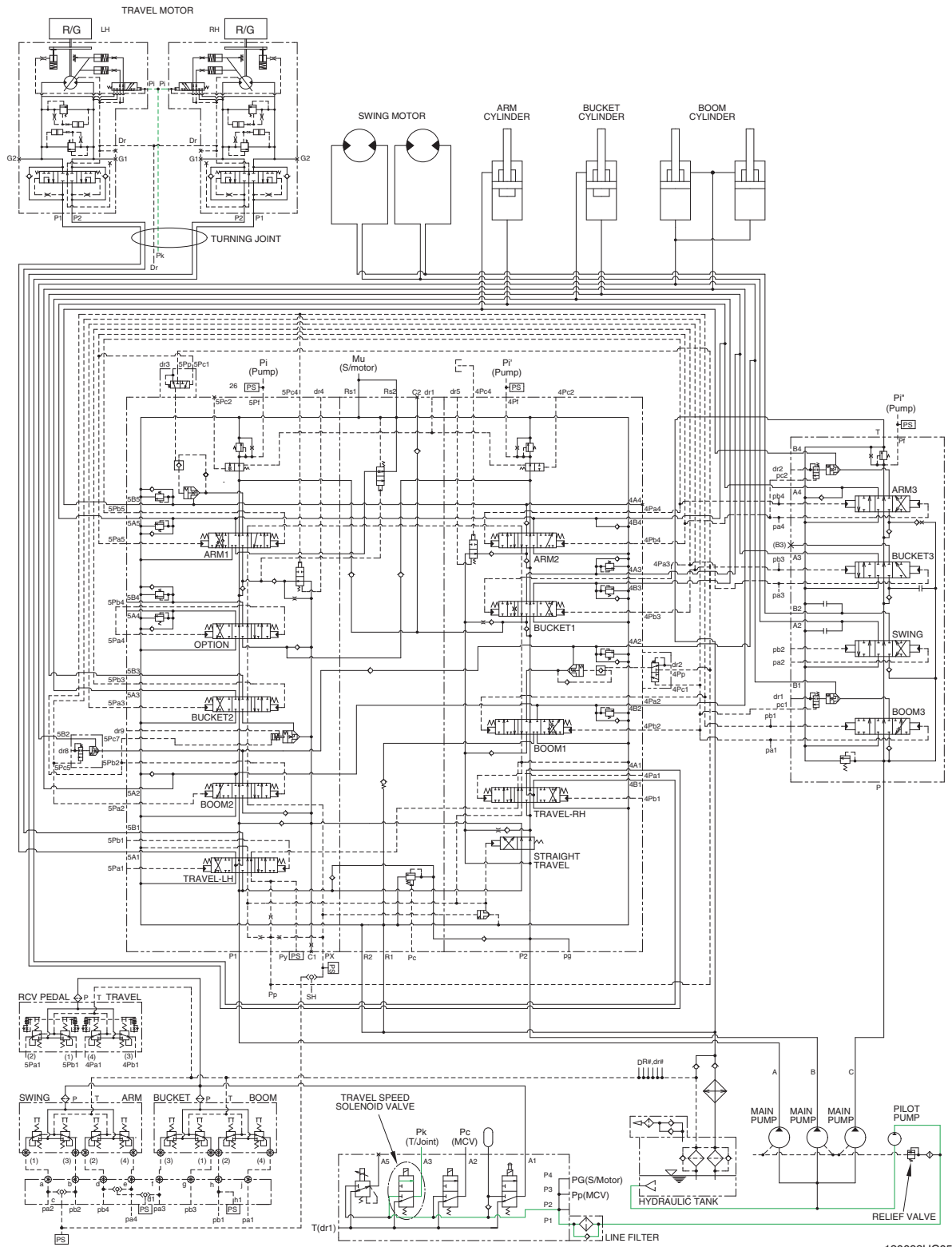

When the travel speed control switch is selected to the high speed, the travel speed solenoid valve is actuated and the discharged oil from the pilot pump flows to the **Pi** port of pilot valve in the travel motors.

As a result, the control piston is pushed by the main oil flow, thus the displacement is minimized.

When the travel speed control switch is pushed once more, the travel speed solenoid valve is return to original position by the force of spring, the hydraulic oil of **Pi** port Pb returns to the hydraulic tank.

As a result, the control piston is returned by the main oil flow, thus the displacement is maximized.

4. MAIN RELIEF PRESSURE CHANGE CIRCUIT

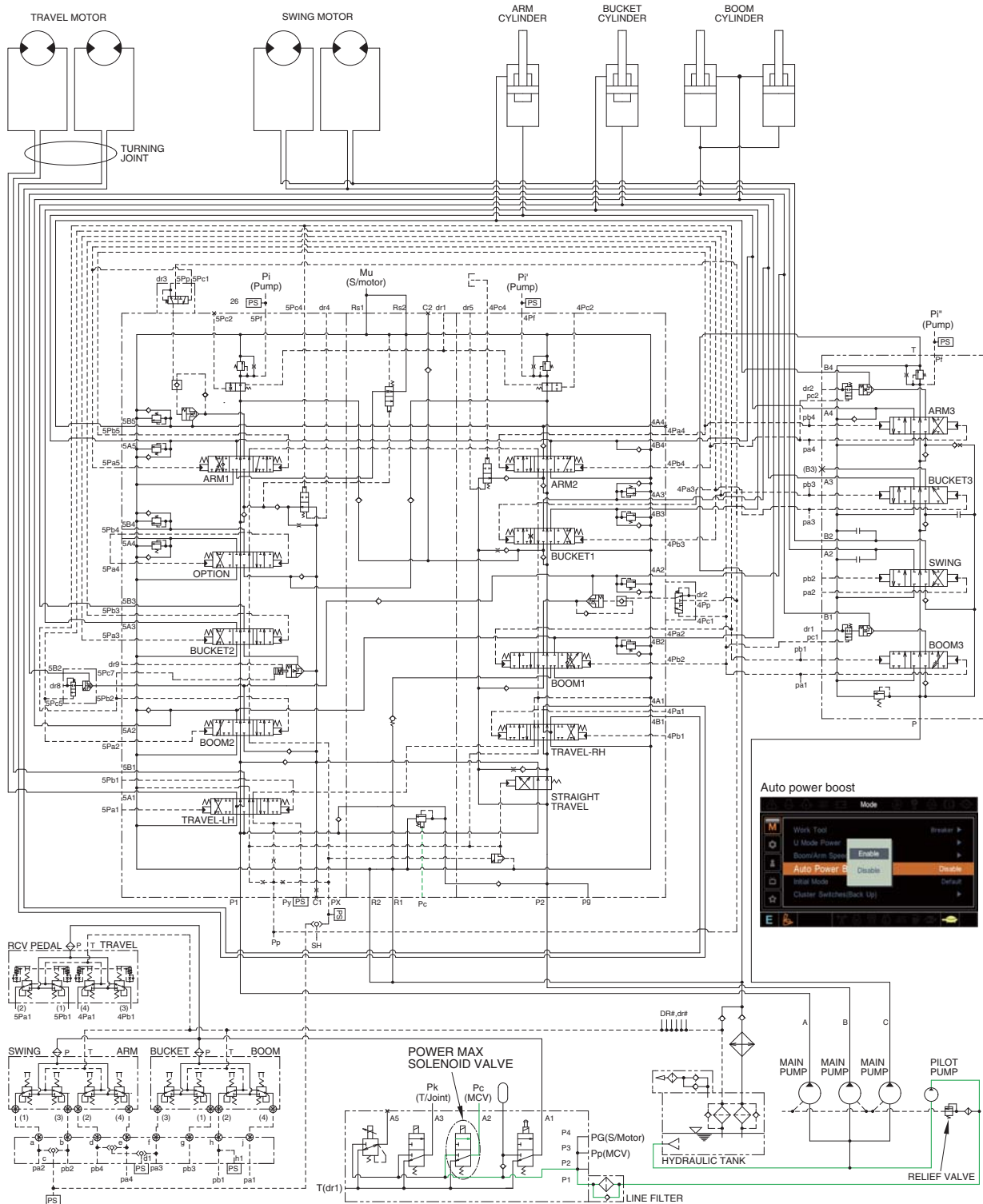

When the power max switch on the left control lever is pushed ON, the power max solenoid valve is actuated, the discharged oil from the pilot pump flow into Pc port of the main relief valve of main control valve; Then the setting pressure of the main relief valve is raises from 320 kgf/cm² to 350 kgf/cm² for increasing the digging power. And even when press continuously, it is canceled after 8 seconds.

5. SWING PARKING BRAKE RELEASE

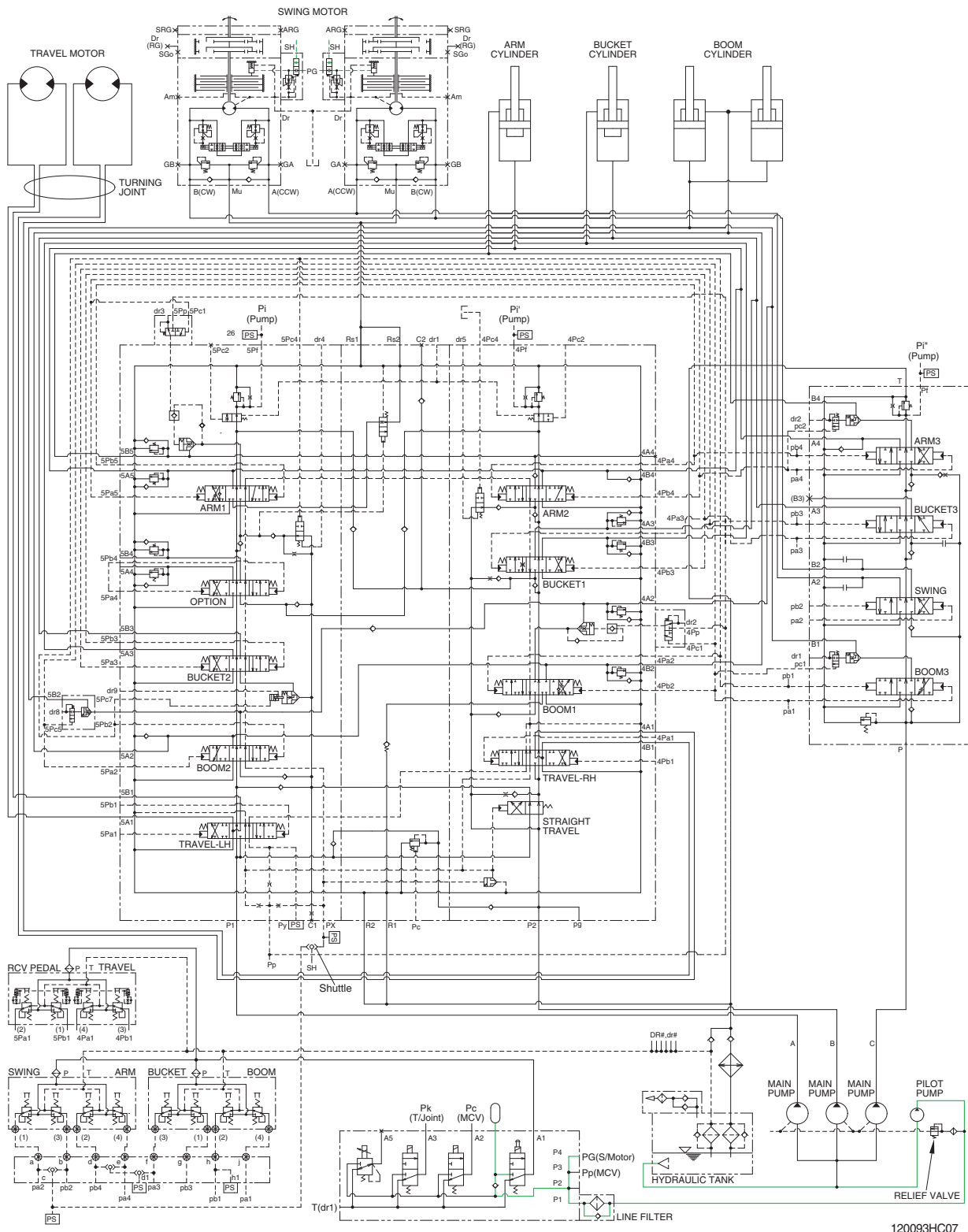

120093HC07

When one of the RCV levers is tilted, the pilot oil flows into SH port through the shuttle. This pressure moves spool so, discharged oil from pilot valve flows to swing motor PG port. This pressure is applied to swing motor disc, thus the brake is released. When all of the RCV lever are set in the neutral position, oil in the swing motor disc cylinder is drained, thus the brake is applied.

GROUP 4 SINGLE OPERATION

1. BOOM UP OPERATION

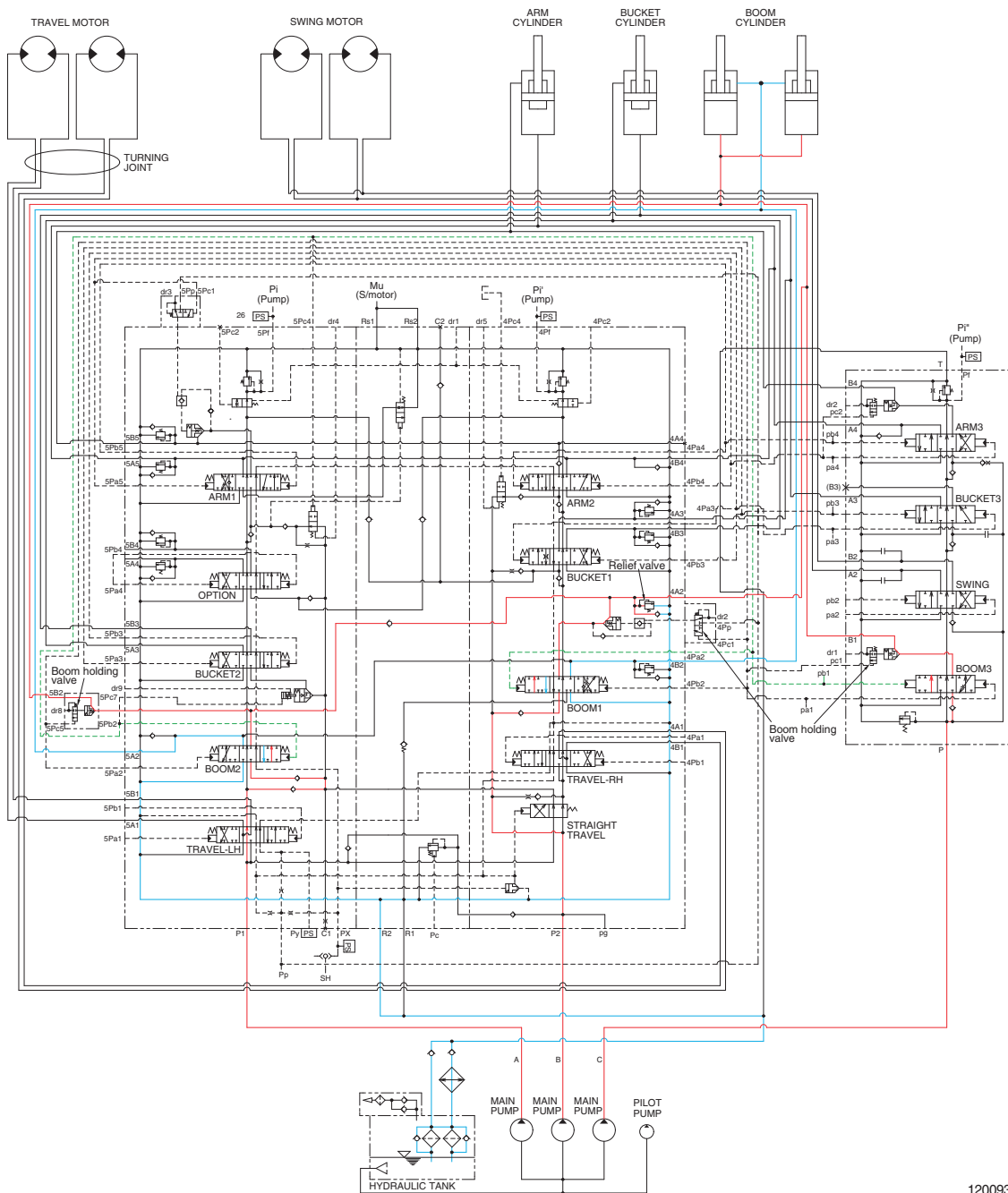

120093HC10

When the RH control lever is pulled back, the boom spools in the main control valve are moved to the up position by the pilot oil pressure from the remote control valve. The oil from the A, B and C pump flows into the main control valve and then goes to the large chamber of boom cylinders. At the same time, the oil from the small chamber of boom cylinders returns to the hydraulic oil tank through the boom spool in the main control valve. When this happens, the boom goes up. The excessive pressure in the boom cylinder bottom end circuit is prevented by relief valve. When the boom is up and the control lever is returned to neutral position, the circuit for the holding pressure at the bottom end of the boom cylinder is closed by the boom holding valve. This prevents the hydraulic drift of boom cylinder.

4. ARM OUT OPERATION

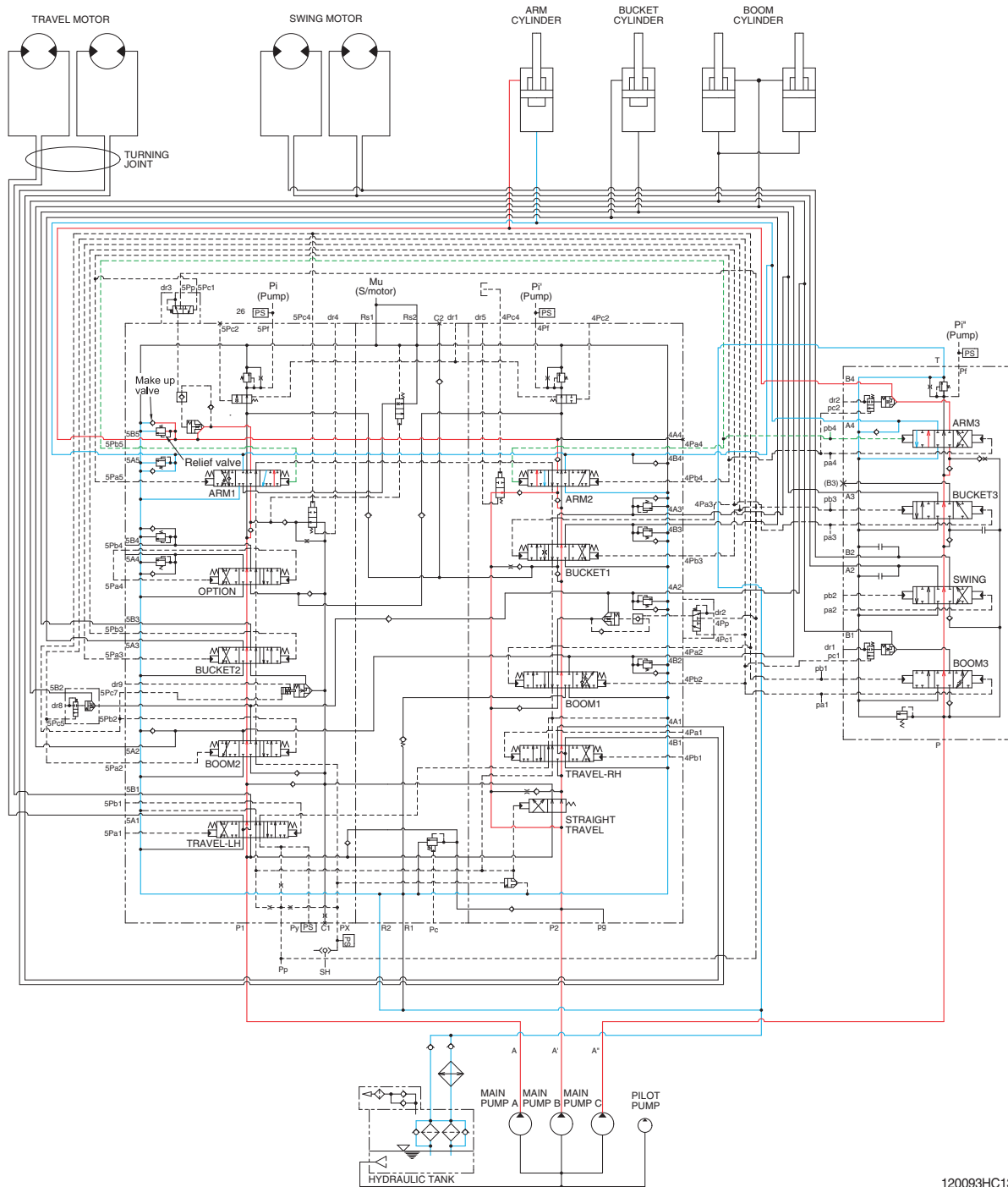

120093HC13

When the LH control lever is pushed forward, the arm spools in the main control valve are moved to the roll out position by the pilot oil pressure from the remote control valve.

The oil from the A, B and C pump flows into the main control valve and then goes to the small chamber of arm cylinder.

At the same time, the oil from the large chamber of arm cylinder returns to the hydraulic oil tank through the arm spools in the main control valve. When this happens, the arm rolls out.

The excessive pressure in the arm cylinder rod side is prevented by relief valve.

When the arm is roll out and the control lever is returned to neutral position, the circuit for the holding pressure at the rod side of the arm cylinder is closed by the arm holding valve.

The cavitation which will happen to the rod side of the arm cylinder is also prevented by the make-up valve in the main control valve.

5. BUCKET IN OPERATION

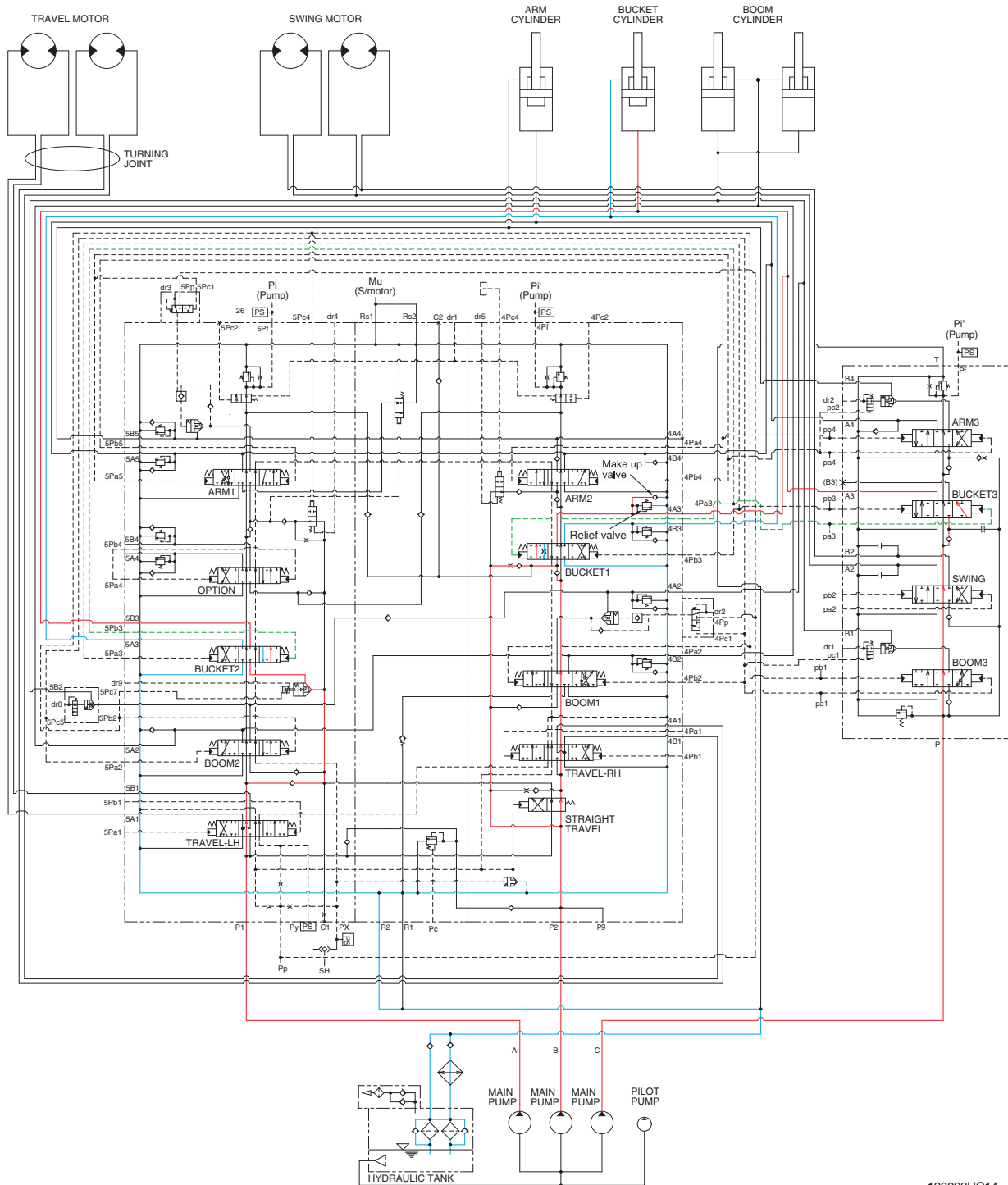

120093HC14

When the RH control lever is pulled left, the bucket spools in the main control valve are moved to the roll in position by the pilot oil pressure from the remote control valve.

The oil from the A, B and C pump flows into the main control valve and then goes to the large chamber of bucket cylinder.

At the same time, the oil from the small chamber of bucket cylinder returns to the hydraulic oil tank through the bucket spools in the main control valve. When this happens, the bucket rolls in.

The excessive pressure in the bucket cylinder head side is prevented by relief valve.

The cavitation which will happen to the head side of the bucket cylinder is also prevented by the make-up valve in the main control valve.

6. BUCKET OUT OPERATION

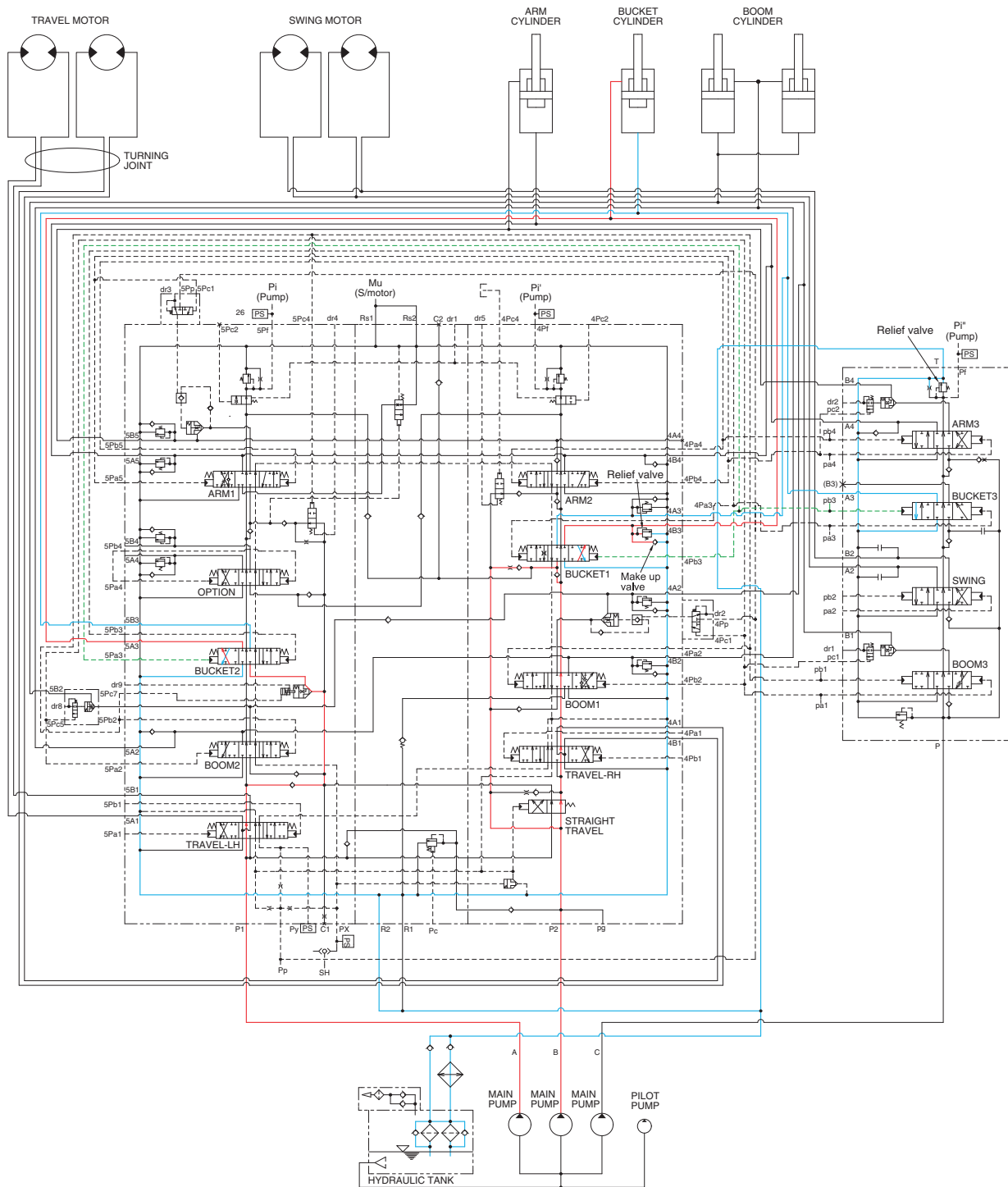

120093HC15

When the RH control lever is pushed right, the bucket spools in the main control valves are moved to the roll out position by the pilot oil pressure from the remote control valve.

The oil from the A and B pumps flow into the main control valve and then goes to the small chamber of bucket cylinder.

At the same time, the oil from the large chamber of bucket cylinder returns to the hydraulic oil tank through the bucket spools in the main control valve. When this happens, the bucket rolls out.

The excessive pressure in the bucket cylinder rod side is prevented by relief valve.

The cavitation which will happen to the rod side of the bucket cylinder is also prevented by the make-up valve in the main control valve.

SWING CIRCUIT OPERATION

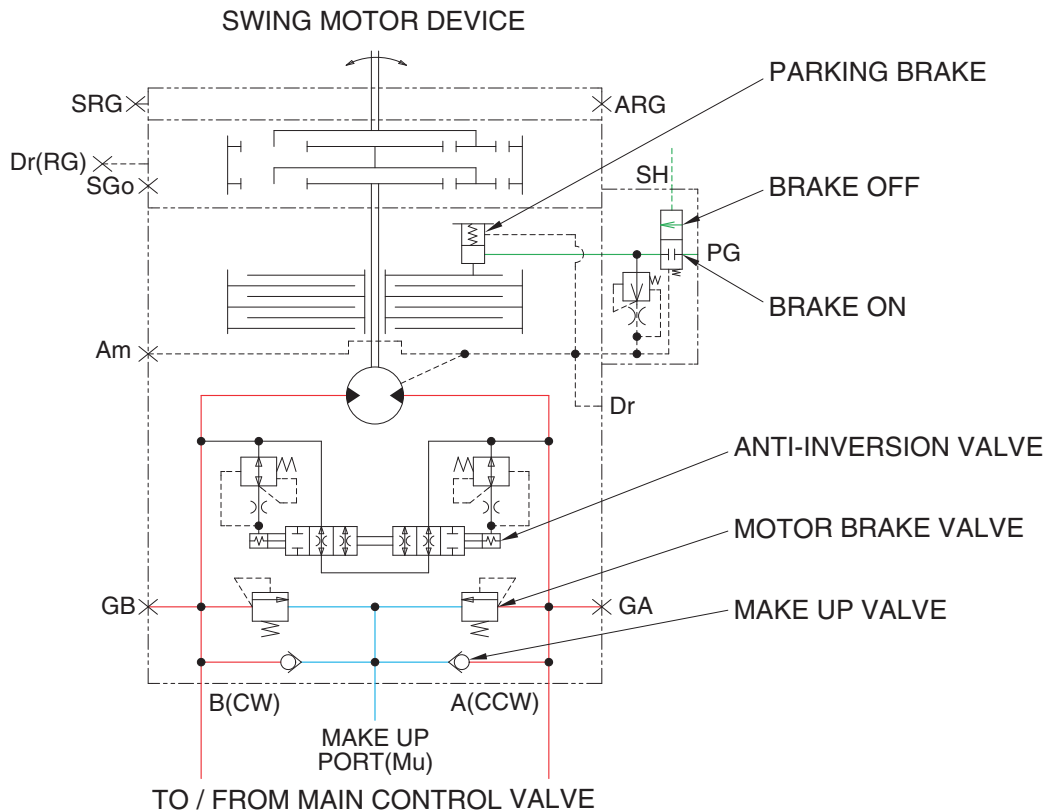

120093HC17

1) MOTOR BRAKE VALVE

Motor brake valve for the swing motor limits to cushion the starting and stopping pressure of swing operation and controls the swing motor operating pressure.

2) MAKE UP VALVE

The make up valves prevent cavitation by supplying return oil to the vacuum side of the motor.

3) PARKING BRAKE

This is function as a parking brake only when all of the RCV lever (except travel pedal) are not operated.

PARKING BRAKE "OFF" OPERATION

The parking brake is released by the pilot pressure oil from the pilot pump.

When the RCV lever placed in the operating position, the pilot oil flows into SH port through the MCV. This pressure transferred to the brake release valve and the brake release valve is change over. Then the pilot oil pressure PG lift the brake piston and release the parking brake.

PARKING BRAKE "ON" OPERATION

When all of the RCV lever placed in the neutral position, the pressure of the pilot oil passage down. Then the brake release valve returned to the neutral position and the oil is returned from the brake piston to the tank. And the brake is set to 'ON'.

4) ANTI-INVERSION VALVE

This anti-inversion valve absorbs shocks produced as swing motion stops and reduced oscillation cause by swing motion.

8. TRAVEL FORWARD AND REVERSE OPERATION

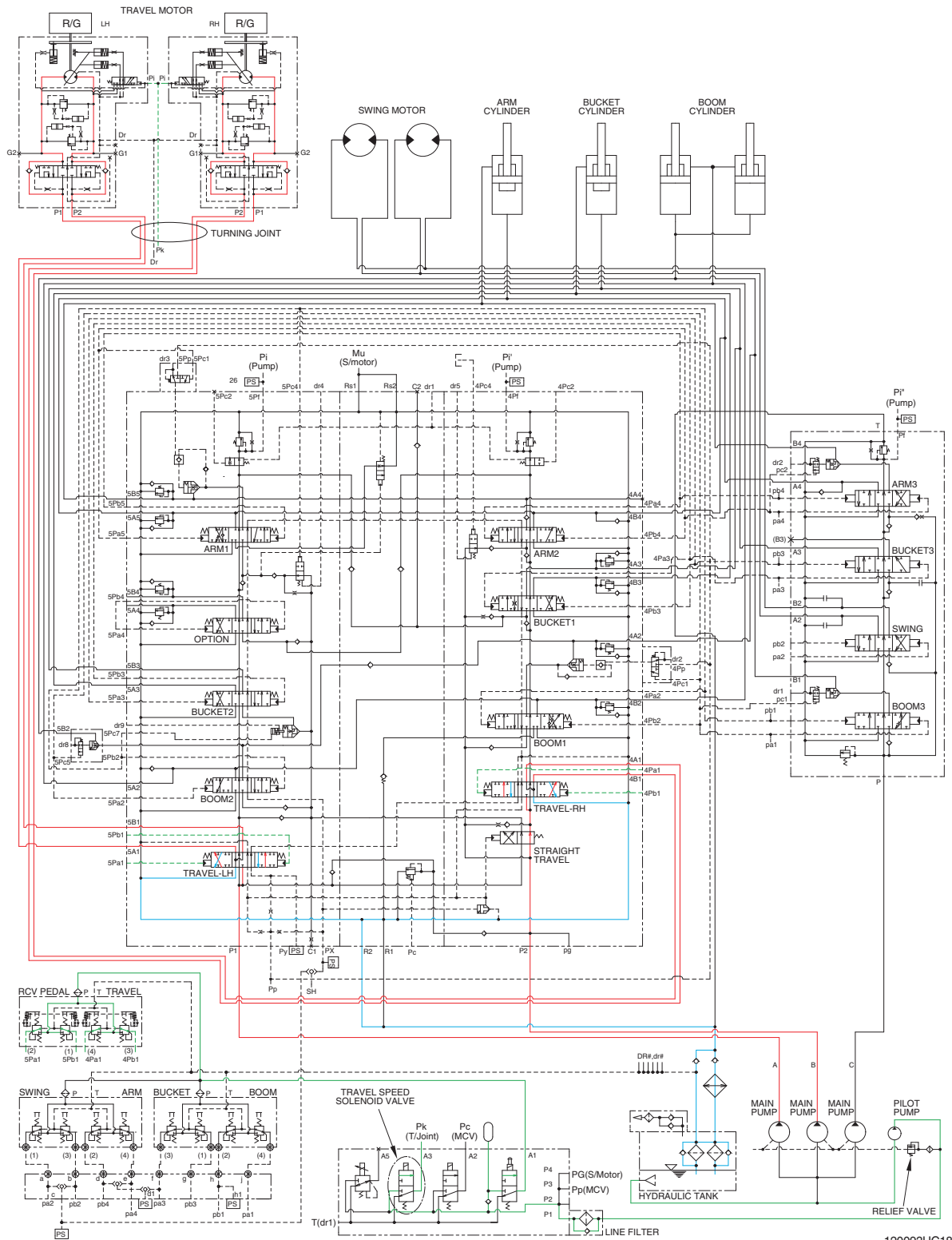

When the travel levers are pushed forward or reverse position, the travel spools in the main control valve are moved to the forward or reverse travel position by the pilot oil pressure from the remote control valve.

The oil from the A and B pump flows into the main control valve and then goes to the each travel motor through the turning joint.

The return oil from both travel motors returns to the hydraulic oil tank through the turning joint and the travel spools in the main control valve.

When this happens, the machine moves to the forward or reverse.

TRAVEL CIRCUIT OPERATION

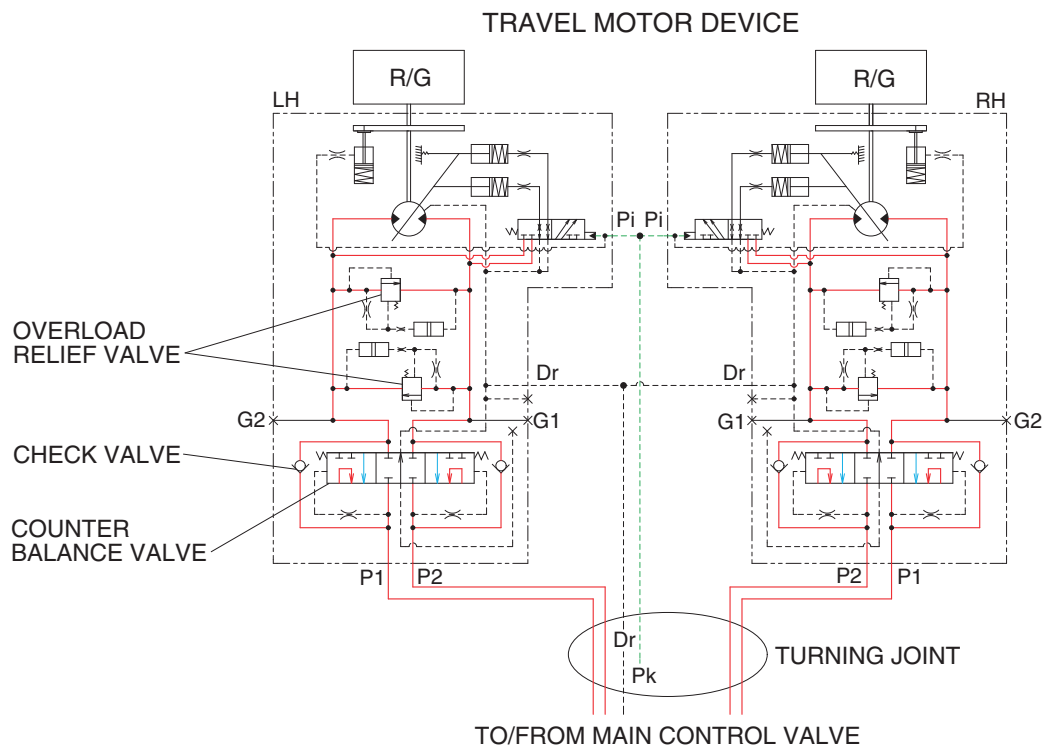

120093HC19

Valves are provided on travel motors to offer the following functions.

1) CHECK VALVE

Stopping the motor, this valve sucks the oil from lower pressure passage for prevention the negative pressure and the cavitation of the motor.

2) COUNTER BALANCE VALVE

When stopping the motor of slope descending, this valve to prevent the motor over run.

3) OVERLOAD RELIEF VALVE

Relief valve limit the circuit pressure below 345 kgf/cm² to prevent high pressure generated at a time of stopping the machine. Stopping the motor, this valve sucks the oil from lower pressure passage for preventing the negative pressure and the cavitation of the motor.

GROUP 5 COMBINED OPERATION

1. OUTLINE

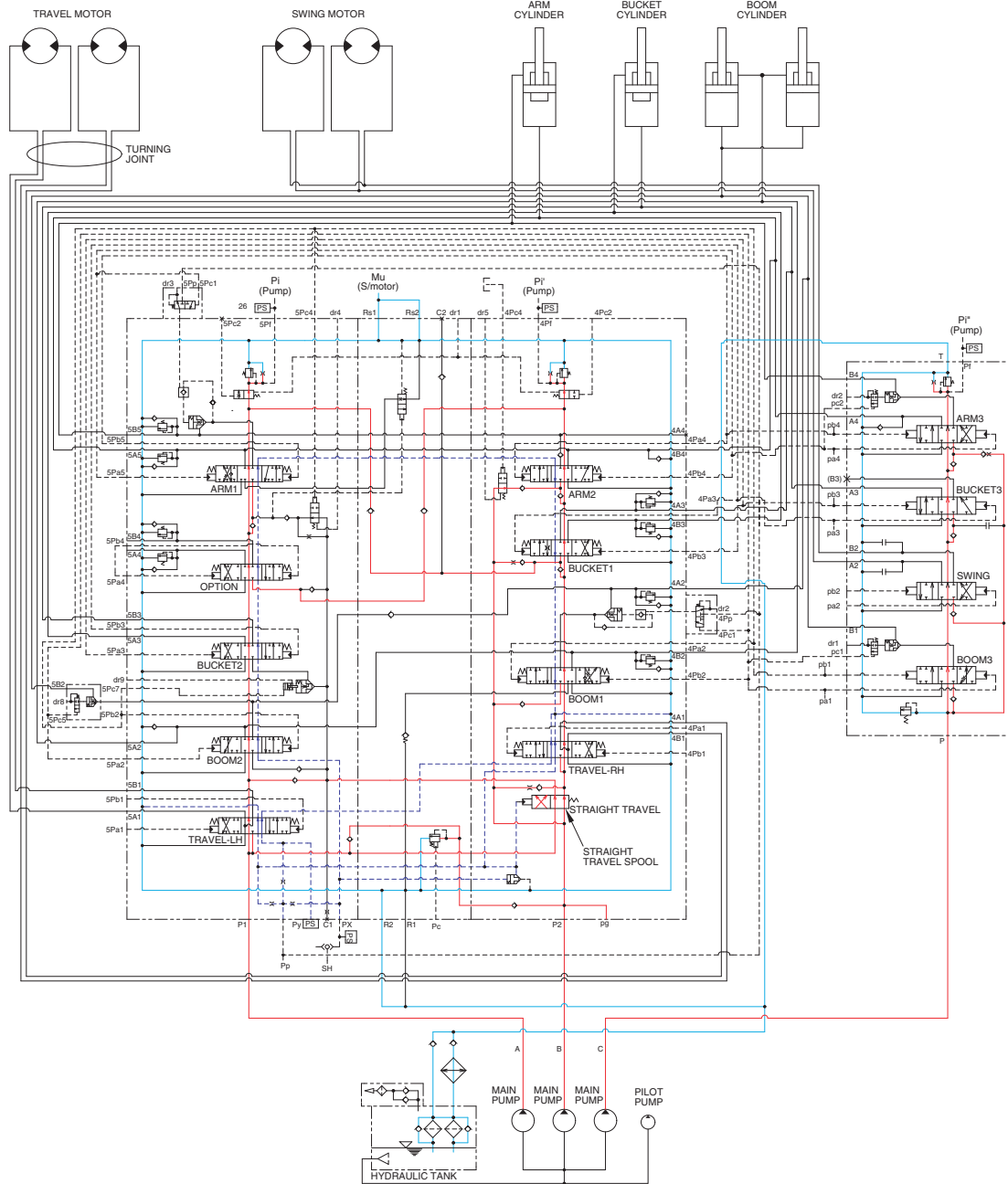

120093HC20

The oil from the A, B and C pump flows through the neutral oil passage, bypass oil passage and confluence oil passage in the main control valve. Then the oil goes to each actuator and operates them. Check valves and orifices are located on these oil passage in the main control valve. These control the oil from the main pumps so as to correspond to the operation of each actuator and smooth the combined operation.

STRAIGHT TRAVEL SPOOL

This straight travel spool is provided in the main control valve.

If any actuator is operated when traveling, the straight travel spool is pushed to the right by the pilot oil pressure from the pilot pump.

Consequently, the left and right travel oil supply passage are connected, and equivalent amount of oil flows into the left and right travel motors. This keeps the straight travel.

2. COMBINED SWING AND BOOM UP OPERATION

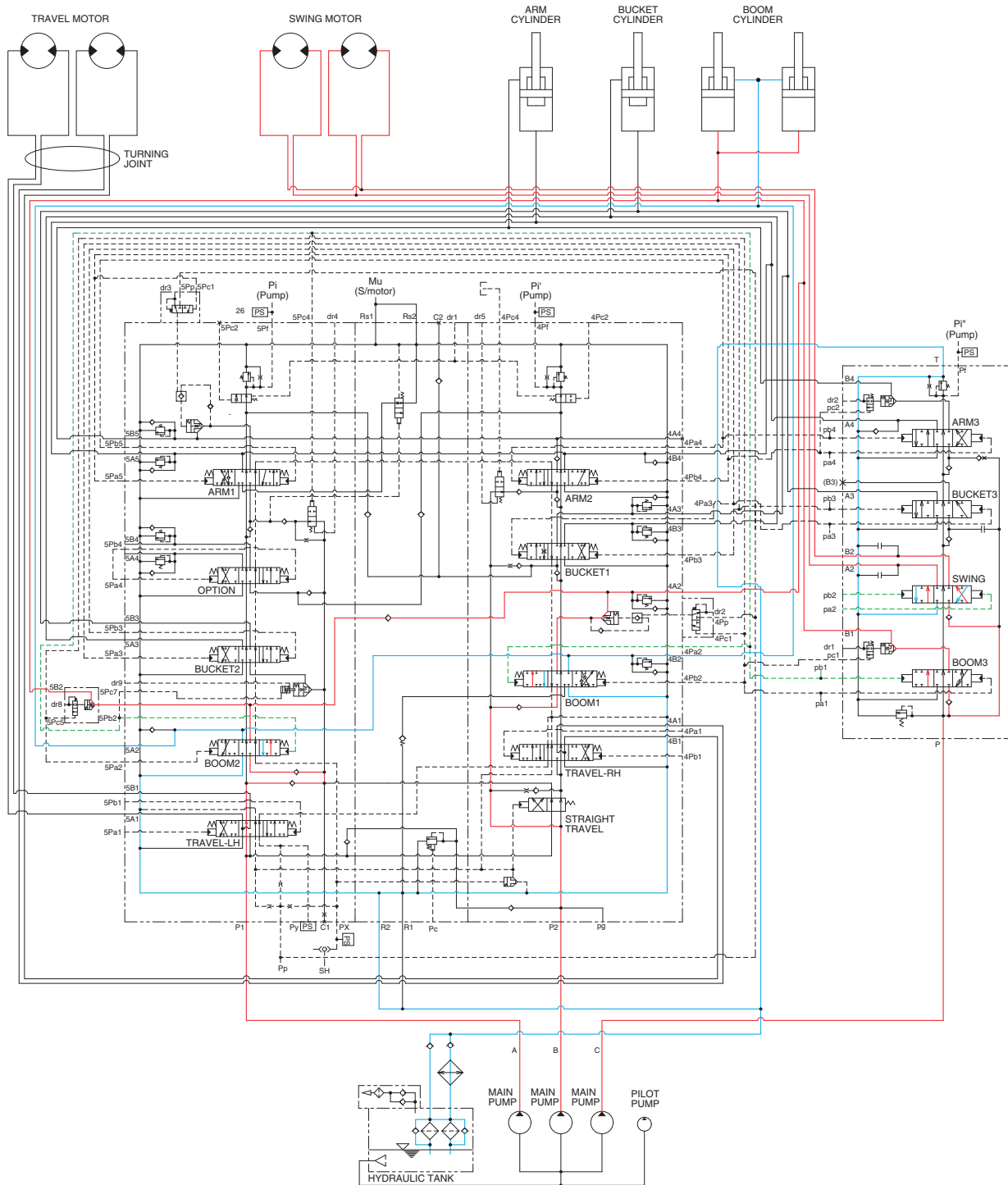

120093HC21

When the swing and boom up functions are operated, simultaneously the swing spool and boom spools in the main control valve are moved to the functional position by the pilot oil pressure from the remote control valve.

The oil from the C pump flows into the swing motor through swing spool and the boom cylinder through boom 3 spool.

The oil from the A and B pump flows into the boom cylinders through the boom 1 and 2 spools in the control valve. The upper structure swings and the boom are operated.

3. COMBINED SWING AND ARM OPERATION

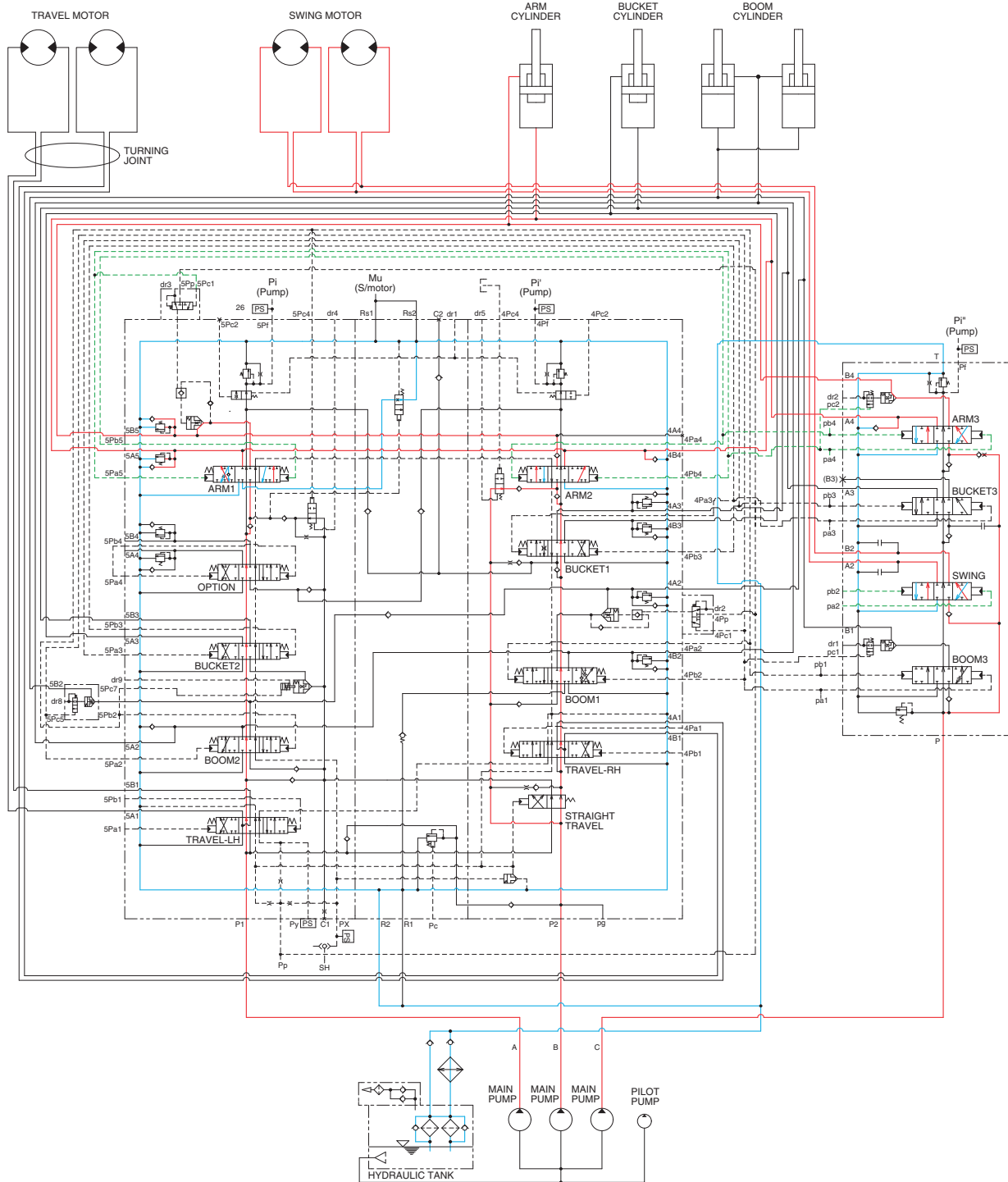

120093HC22

When the swing and arm functions are operated, simultaneously the swing spool and arm spools in the main control valve are moved to the functional position by the pilot oil pressure from the remote control valve.

The oil from the C pump flows into the swing motor through swing spool and the arm cylinder through arm 3 spool.

The oil from the A and B pump flows into the arm cylinder through the arm 1 and 2 spools of the control valve. The upper structure swings and the arm is operated.

4. COMBINED SWING AND BUCKET OPERATION

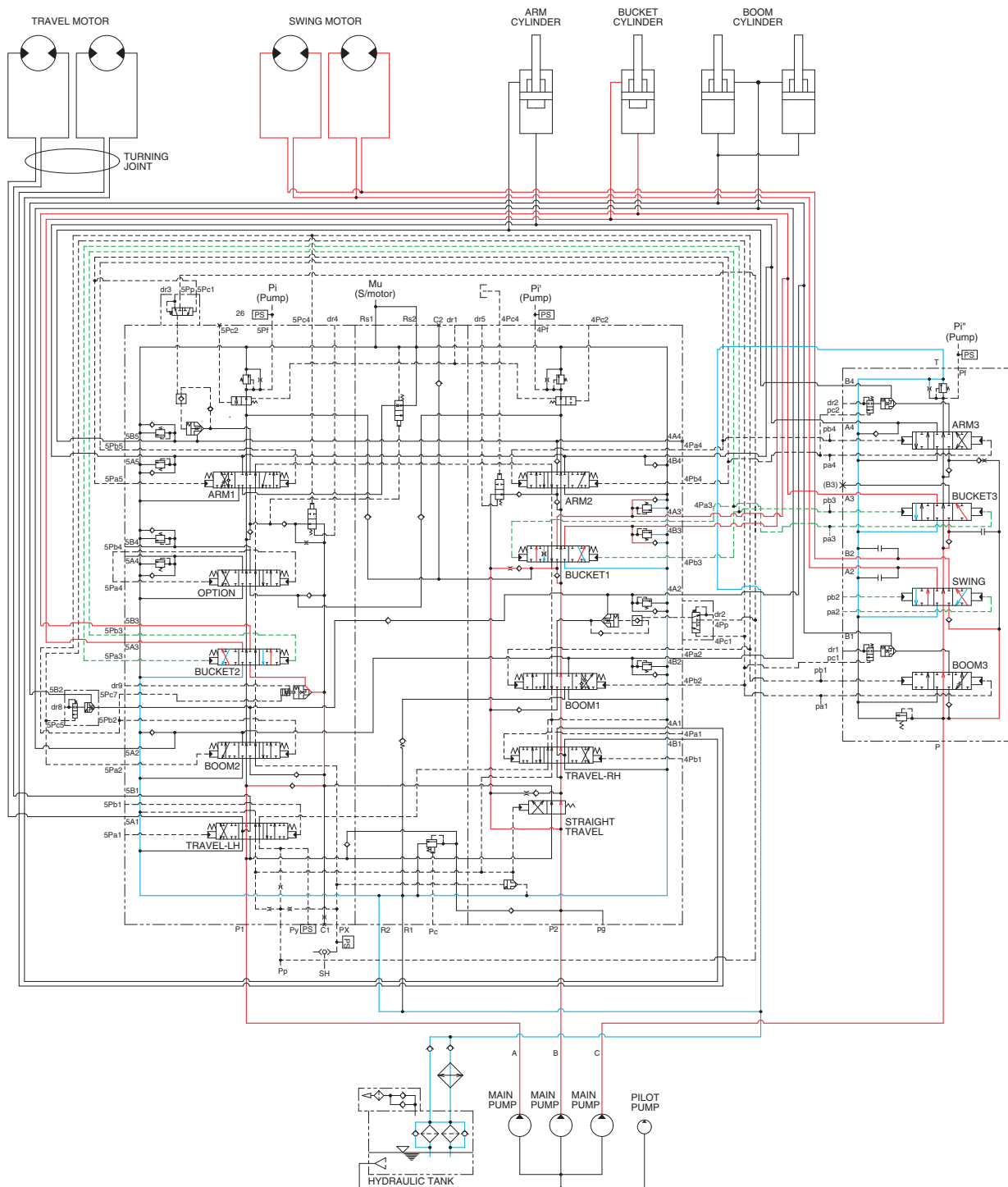

120093HC23

When the swing and bucket functions are operated, simultaneously the swing spool and bucket spools in the main control valve are moved to the functional position by the pilot oil pressure from the remote control valve.

The oil from the C pump flows into the swing motors through the swing spool in the control valve 2.

The oil from the A and B pump flows into the bucket cylinder through the bucket spools in the control valve 1.

The upper structure swings and the bucket is operated.

5. COMBINED SWING AND TRAVEL OPERATION

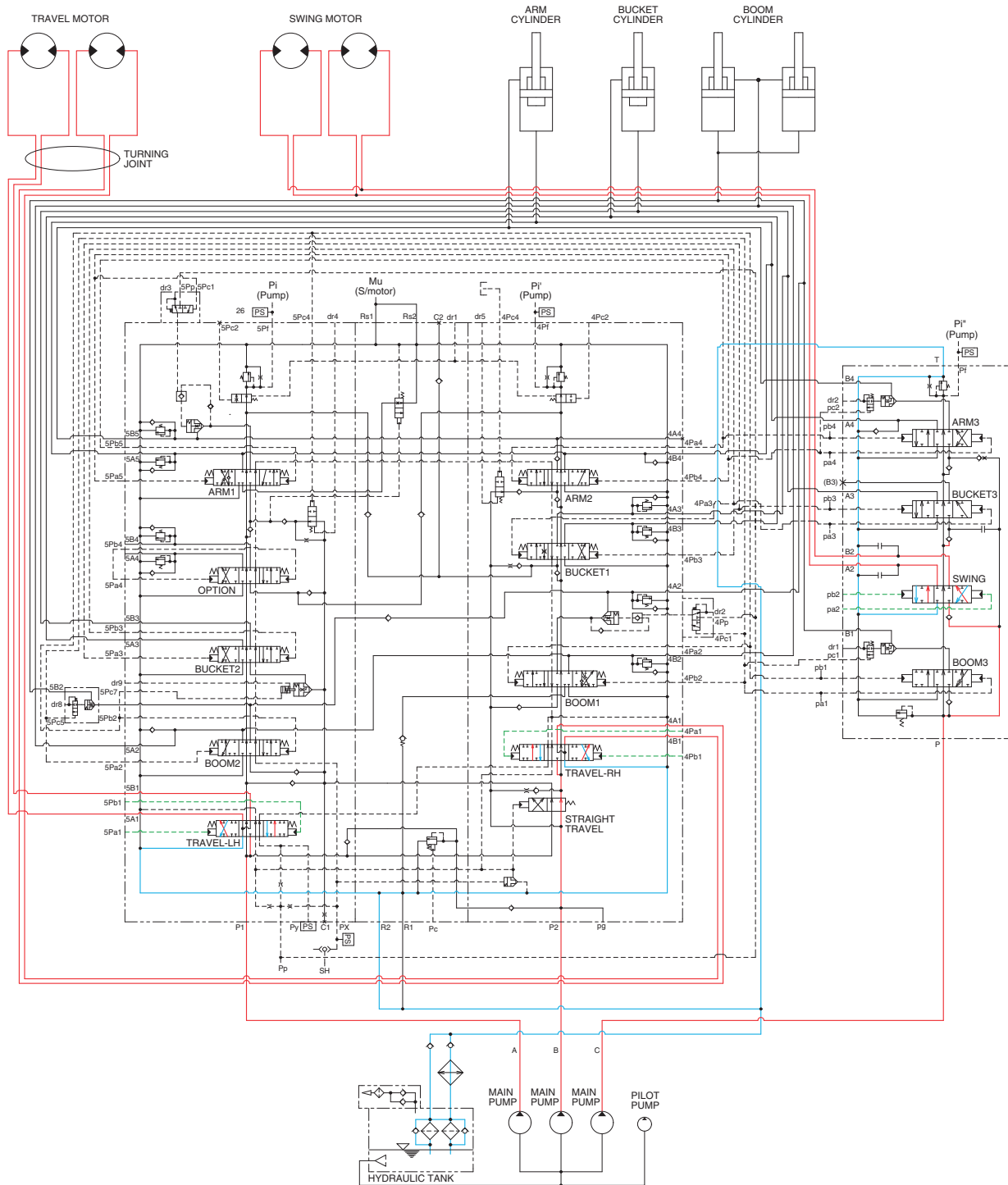

120093HC24

When the swing and travel functions are operated, simultaneously the swing spool and travel spools in the main control valve are moved to the functional position by the pilot oil pressure from the remote control valve and straight travel spool remained its position because the pilot oil pressure from the pilot pump is not applied to the straight travel spool.

The oil from the A pump flows into the LH travel motor through the LH travel spool of the left control valve and the oil from the B pump flows into the RH travel motor through the RH travel spool of the right control valve.

The oil from the C pump flows into the swing motor through the swing spool.

The upper structure swings and the machine travels.

6. COMBINED BOOM AND TRAVEL OPERATION

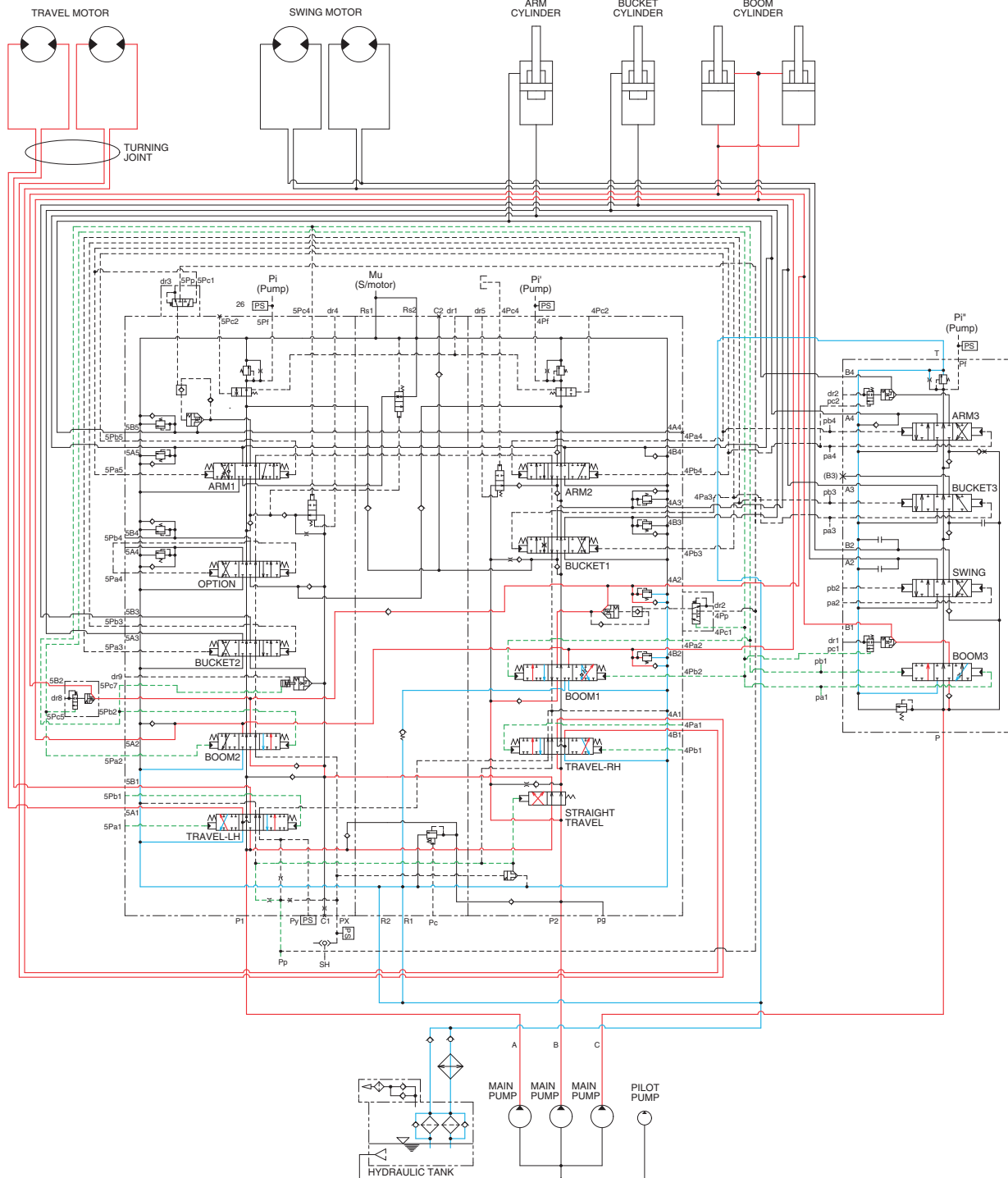

120093HC25

When the boom and travel functions are operated, simultaneously the boom spools and travel spools in the main control valve are moved to the functional position by the pilot oil pressure from the remote control valve and the straight travel spool is pushed to the right by the oil pressure from pilot pump.

The oil from the A pump flows into the travel motors through the LH travel spool of the left control valve and the RH travel spool of the right control valve via the straight travel spool.

The oil from the B pump flows into the boom cylinders through the boom 1 and boom 2 spools via the parallel passage and the straight travel spool.

Also, the oil from the C pump flows into the boom cylinders through the boom 3 spool spool via confluence oil passage in case boom up operation.

The boom is operated and the machine travels straight.

7. COMBINED ARM AND TRAVEL OPERATION

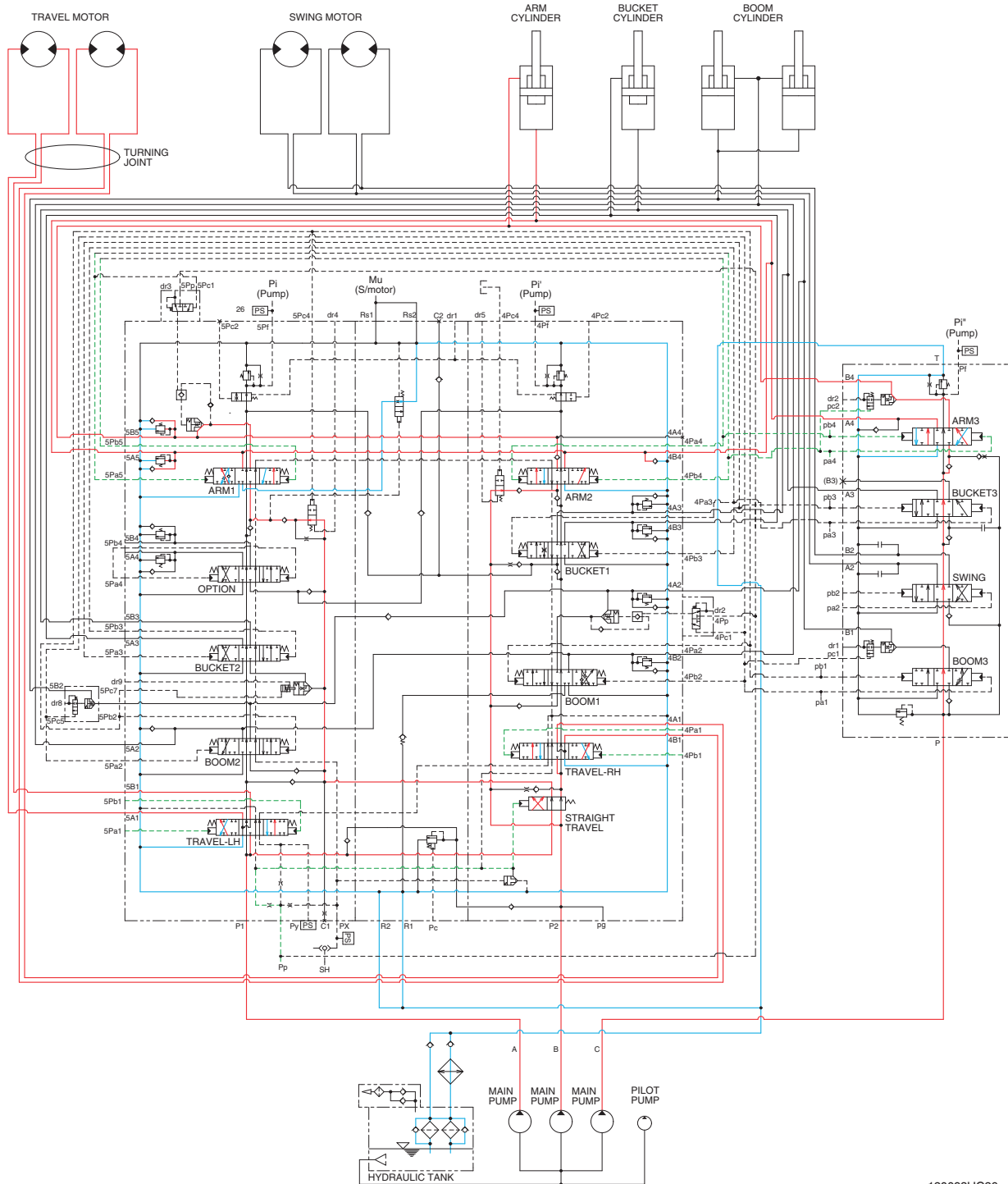

120093HC26

When the arm and travel functions are operated, simultaneously the arm spools and travel spools in the main control valve are moved to the functional position by the pilot oil pressure from the remote control valve and the straight travel spool is pushed to the right by the oil pressure from pilot pump.

The oil from the A pump flows into the travel motors through the LH travel spool of the left control valve and the RH travel spool of the right control valve via the straight travel spool.

The oil from the B pump flows into the arm cylinders through the arm 2 and arm 1 spools via the parallel passage and the straight travel spool.

Also, the oil from the C pump flows into the arm cylinders through the arm 3 spool via confluence oil passage.

The arm is operated and the machine travels straight.

8. COMBINED BUCKET AND TRAVEL OPERATION

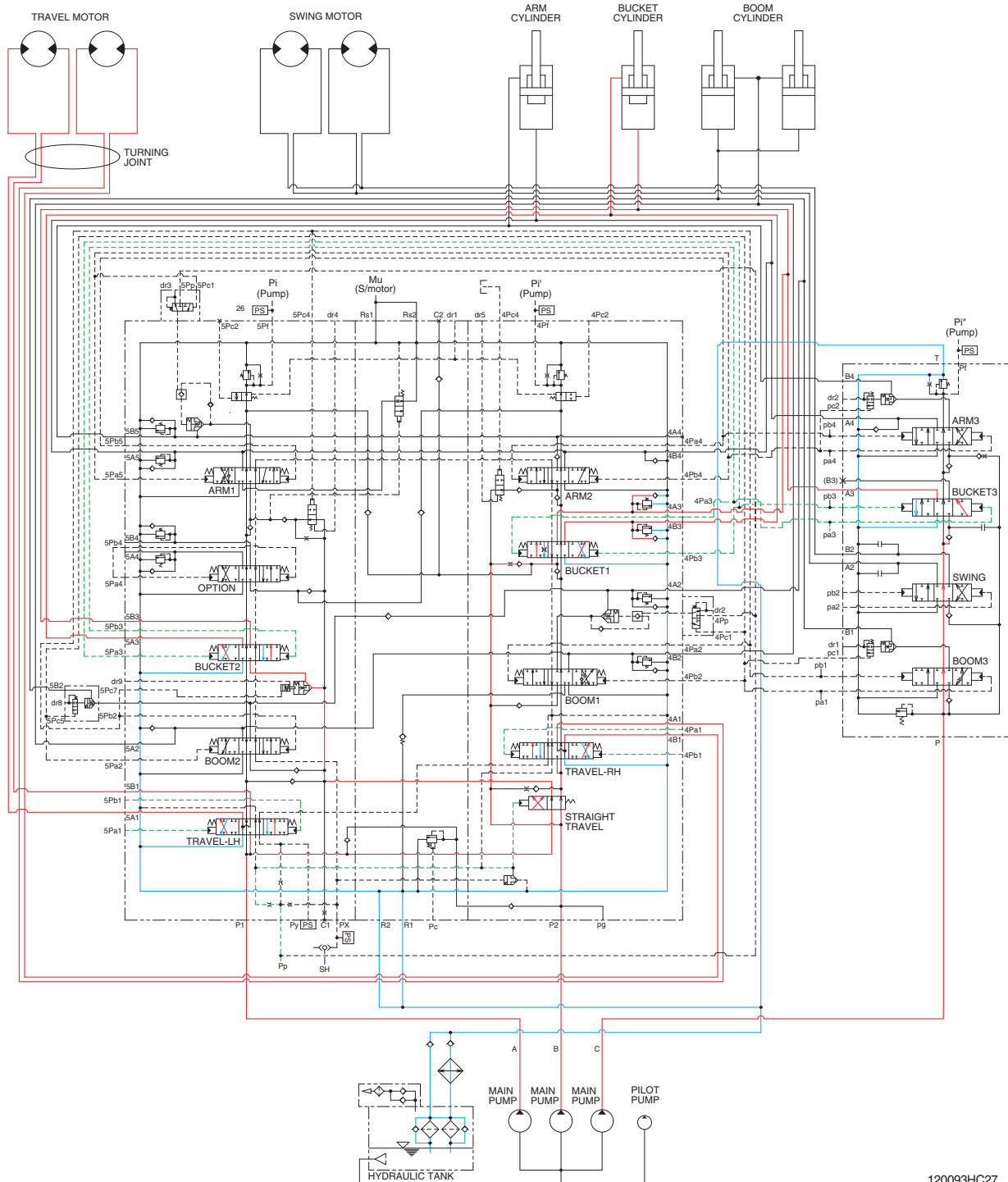

120093HC27

When the bucket and travel functions are operated, simultaneously the bucket spool and travel spools in the main control valve are moved to the functional position by the pilot oil pressure from the remote control valve, and the straight travel spool is pushed to the right by the oil pressure from pilot pump. The oil from the A pump flows into the travel motors through the LH travel spool of the left control valve and the RH travel spool of the right control valve via the straight travel spool of the control valve.

The oil from the B pump flows into the bucket cylinders through the bucket 1 and bucket 2 spools via the parallel passage and the straight travel spool.

Also, the oil from the C pump flows into the bucket cylinder through the bucket 3 spool via the confluence oil passage in case the bucket in operation.

The bucket is operated and the machine travels straight.