

## GROUP 6 TRAVEL DEVICE

### 1. REMOVAL AND INSTALL

#### 1) REMOVAL

- (1) Swing the work equipment 90° and lower it completely to the ground.
- (2) Operate the control levers and pedals several times to release the remaining pressure in the hydraulic piping.
- (3) Loosen the breather slowly to release the pressure inside the hydraulic tank.

**▲ Escaping fluid under pressure can penetrate the skin causing serious injury.**

- ※ When pipes and hoses are disconnected, the oil inside the piping will flow out, so catch it in oil pan.
- (4) Remove the track shoe assembly.  
For details, see removal of track shoe assembly.
  - (5) Remove the cover.
  - (6) Remove the hose.
    - ※ Fit blind plugs to the disconnected hoses.
  - (7) Remove the bolts and the sprocket.
  - (8) Sling travel device assembly (1).
  - (9) Remove the mounting bolts (2), then remove the travel device assembly.
    - Weight : 935 kg( 2060 lb)

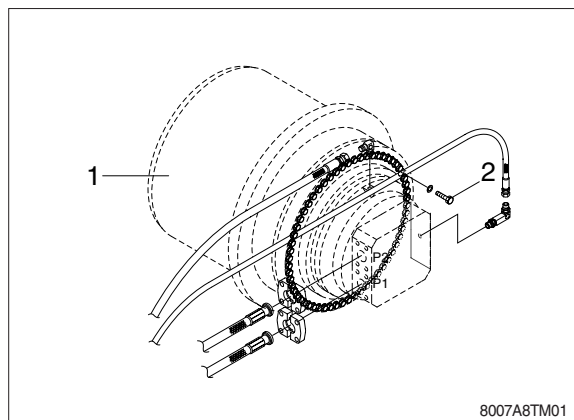

#### 2) INSTALL

- (1) Carry out installation in the reverse order to removal.
- (2) Bleed the air from the travel motor.
  - ① Remove the air vent plug.
  - ② Pour in hydraulic oil until it overflows from the port.
  - ③ Tighten plug lightly.
  - ④ Start the engine, run at low idling, and check oil come out from plug.
  - ⑤ Tighten plug fully.
- (3) Confirm the hydraulic oil level and check the hydraulic oil leak or not.

## 2. TRAVEL MOTOR (1/2)

### 1) STRUCTURE

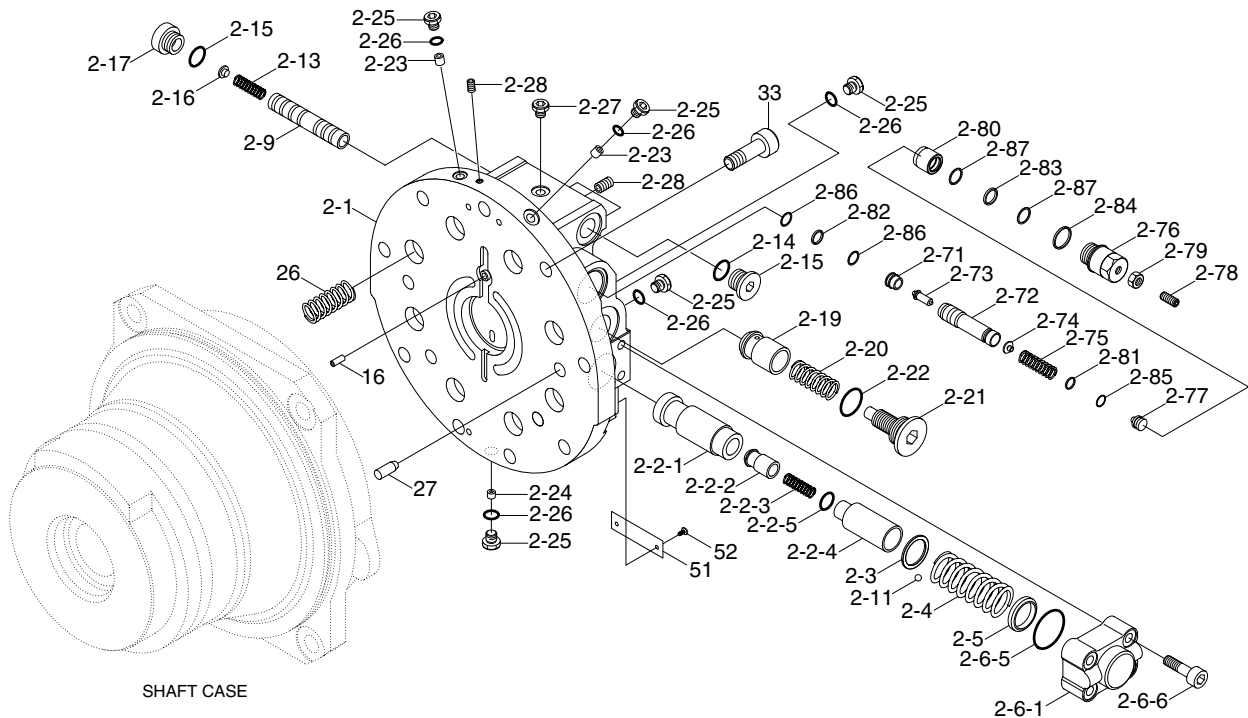

8007A2TM02

2-1	Base plate	2-7-5	Spring	2-15	O-ring
2-2	Spool assy	2-7-6	Plug	2-16	Spring guide
2-2-1	Spool	2-7-7	Spring guide	2-17	Plug
2-2-2	Check valve	2-7-8	Set screw	2-19	Check valve
2-2-3	Spring	2-7-9	Nut	2-20	Spring
2-2-4	Plug	2-80	Free piston	2-21	Plug
2-2-5	O-ring	2-81	O-ring	2-22	O-ring
2-3	Spring seat	2-82	O-ring	2-23	Orifice
2-4	Spring	2-83	O-ring	2-24	Orifice
2-5	Spring seat	2-84	O-ring	2-25	Plug
2-6	Cap assy	2-85	Back up ring	2-26	O-ring
2-6-1	Cap	2-86	Back up ring	2-27	Shipping plug
2-6-5	O-ring	2-87	Back up ring	2-28	Plug
2-6-6	Bolt	2-9	Valve assy	16	Pin
2-7	Relief valve assy	2-9-1	Spool	26	Spring
2-7-1	Poppet seat	2-9-2	Spool-C	27	Pin
2-7-2	Relief housing	2-11	Orifice	33	Socket bolt
2-7-3	Poppet	2-13	Spring	51	Name plate
2-7-4	Spring seat	2-14	Plug	52	Drive screw



## TRAVEL MOTOR (2/2)

### · Control part

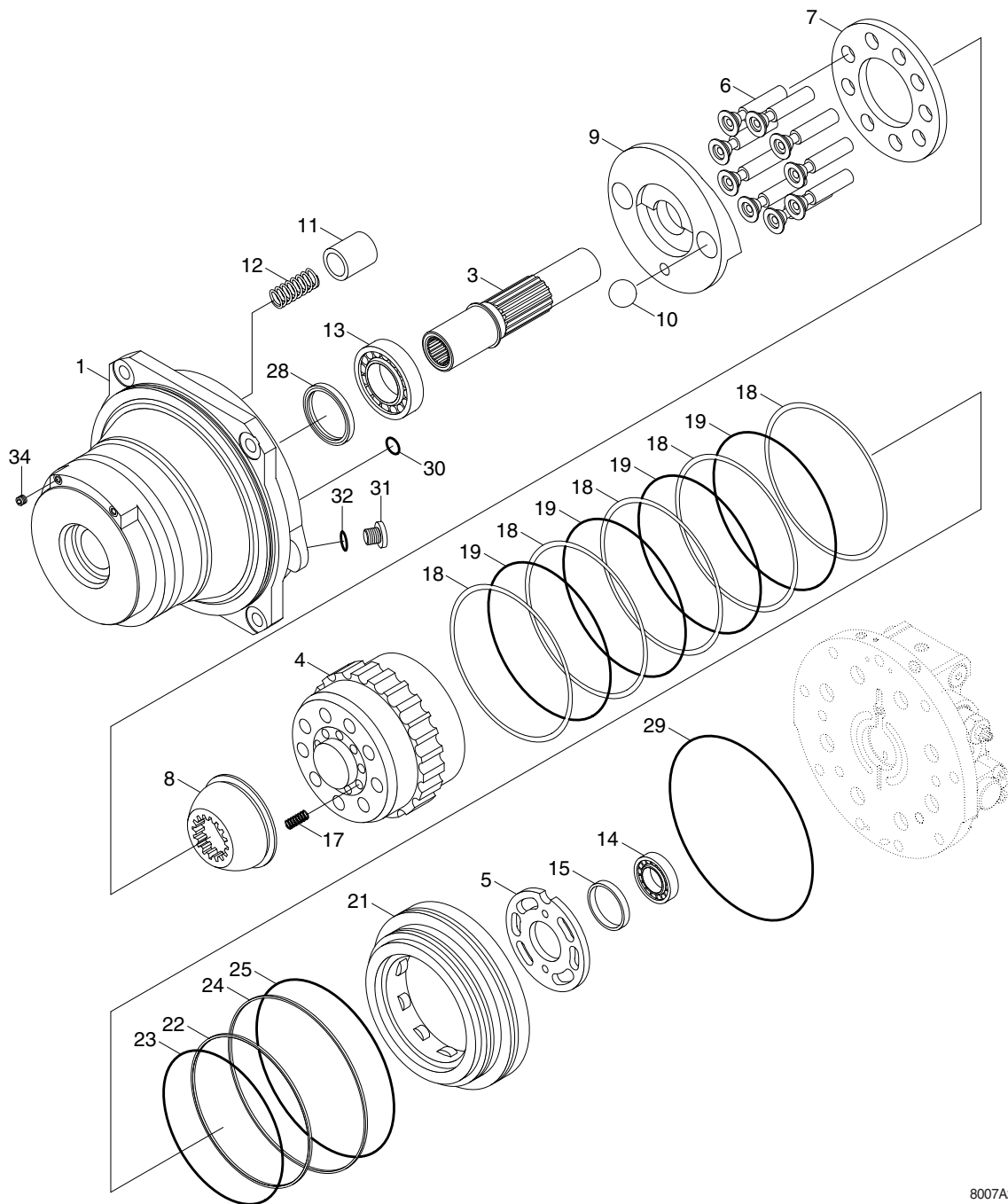

8007A2TM03

- |    |                |    |                |    |              |
|----|----------------|----|----------------|----|--------------|
| 1  | Case           | 12 | Spring         | 24 | O-ring       |
| 3  | Shaft          | 13 | Roller bearing | 25 | Back up ring |
| 4  | Cylinder block | 14 | Roller bearing | 28 | Oil seal     |
| 5  | Valve plate    | 15 | Collar         | 29 | O-ring       |
| 6  | Piston assy    | 17 | Spring         | 30 | O-ring       |
| 7  | Retainer plate | 18 | Friction plate | 31 | Plug         |
| 8  | Plate holder   | 19 | Disc plate     | 32 | O-ring       |
| 9  | Swash plate    | 21 | Brake piston   | 34 | Plug         |
| 10 | Steel ball     | 22 | O-ring         |    |              |
| 11 | Piston assy    | 23 | Back up ring   |    |              |

## 2) MAINTENANCE INSTRUCTION

### (1) Tools for disassembly and reassembly

No.	Tool name	Specification	Applicable Components or Parts
1	Torque wrench	60 kgf · m (434 lbf · ft)	Orifice (2-11)
2		900 kgf · m (6510 lbf · ft)	Plug (2-2-4, 2-25), Nut (2-7-9), Orifice (2-23)
3		1800 kgf · m (13019 lbf · ft)	Bolt (2-6-6), Plug (2-14, 2-17)
4		5600 kgf · m (40505 lbf · ft)	Valve assy (2-7), Plug (2-21), Socket bolt (33)
5	Ratchet steering wheel for socket wrench		
6	Hexagonal bit for torque wrench	Hex. 2.5	Orifice (2-11)
7		Hex. 4	Orifice (2-23, 2-24)
8		Hex. 5	
9		Hex. 6	Set screw (2-7-8), Plug (2-25)
10		Hex. 10	Bolt (2-6-6), Plug (2-14, 2-17)
11		Hex. 12	Plug (31)
12		Hex. 14	Plug (2-2-4, 2-21), Socket bolt (33)
13	Socket	Hex. 21	
14		Hex. 36	Relief valve assy (2-7)
15	Hexagon socket screw key	Hex. 2.5	Orifice (2-11)
16		Hex. 4	Orifice (2-23, 2-24)
17		Hex. 5	
18		Hex. 6	Set screw (2-7-8), Plug (2-25)
19		Hex. 10	Bolt (2-6-6), Plug (2-14, 2-17)
20		Hex. 12	Plug (31)
21		Hex. 14	Plug (2-2-4, 2-21), Socket bolt (33)
22	Spanner	Hex. 19	Nut (2-7-9)
23		Hex. 21	
24		Hex. 36	Relief valve assy (2-7)
25	Minus driver	6 × 100	Base plate assy (2), Valve plate (5)
26	Plastic hammer	#3	
27	Punch	About 10 mm	
28	Hand Press	200 kgf or more	
29	Crane	For 400 kg	
30	Eyebolt	M12	Case (1), Base plate assy (2), Base plate (2-1)
31	Chain string (wire)		

### 3) DISASSEMBLY

#### (1) General precautions

- ① Before disassembling the motor, check the items to be inspected and, for remedy against trouble, closely examine the nature of the trouble, so that the motor can be disassembled
- ② effectively.

To disassemble the motor, use the disassembling procedures described in section 2) and select

- ③ a clean place.

Place a rubber or vinyl sheet or other such protective materials on your working bench to protect

- ④ the surface of the motor to be serviced.

- ⑤ During disassembly, give a match mark to the mating surfaces of each part.

Arrange removed parts in order so that they will not become damaged or missing during

- ⑥ disassembly.

Once seals have been disassembled, they should be replaced even if damage is not observed.

Have replacement seals ready on hand before starting your disassembling job.

## (2) DISASSEMBLY TRAVEL MOTOR

- ① Remove cap (2-6) and take out spring (37), spring seat (36).

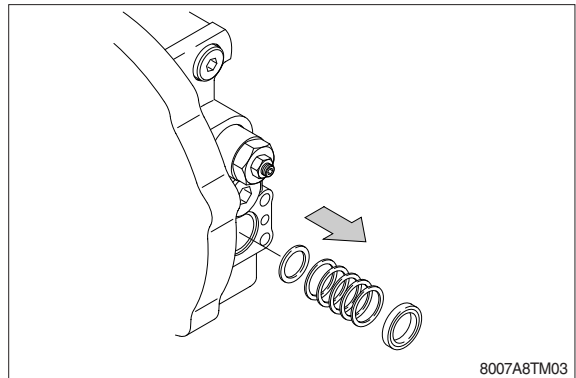
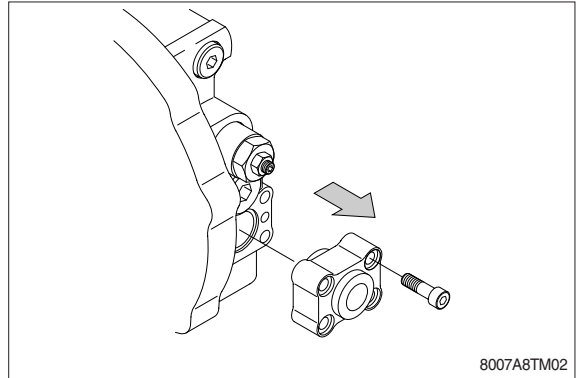

- ② Remove spool assy (2-2) turning slowly. Be careful not to damage around the spool assy.

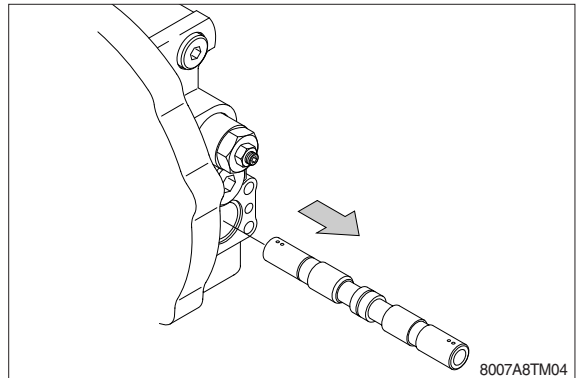

- ③ Loosen the plug (2-7-6) to remove the relief valve assembly (2-7).
  - ※ Do not move the setscrew, nut. Otherwise, the set pressure will change.
  - ※ Do not disassemble the relief valve assembly because it is a functional component.

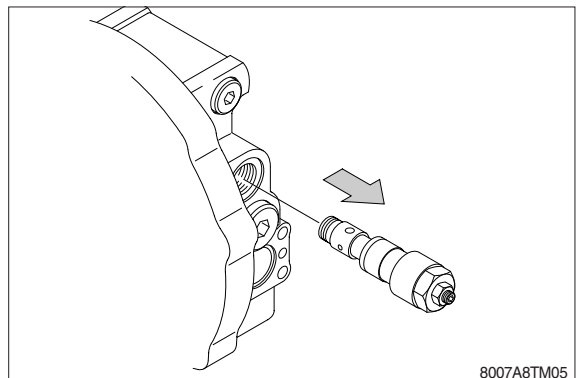

- ④ Remove plug (2-21), spring (2-20) and check valve (2-19).

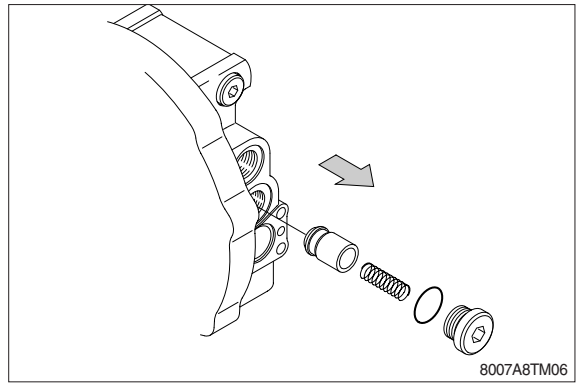

- ⑤ Remove Plugs (2-14, 2-17) remove spring (2-13) and spool assy (2-9).

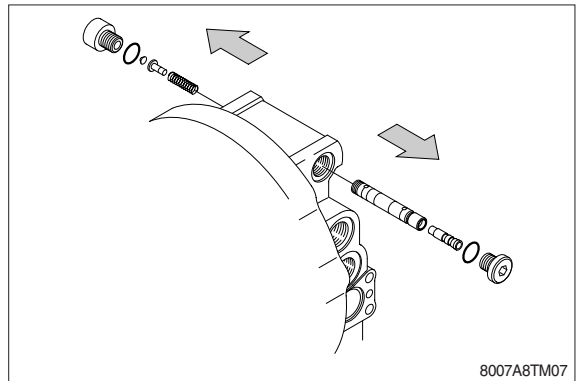

- ⑥ Remove socket head bolt (33).

- Points

To disassemble the motor easily, socket head bolt (33) should be loosened evenly because base plate (1-2-1) lift up by the reactive force of springs (26).

- Remove base plate (1-2-1).

Then, pay attention so that cylinder block does not come out. When it is difficult to remove, strike it by use of plastic hammer. If it is more difficult to remove, remove it by lightly prying with screwdriver.

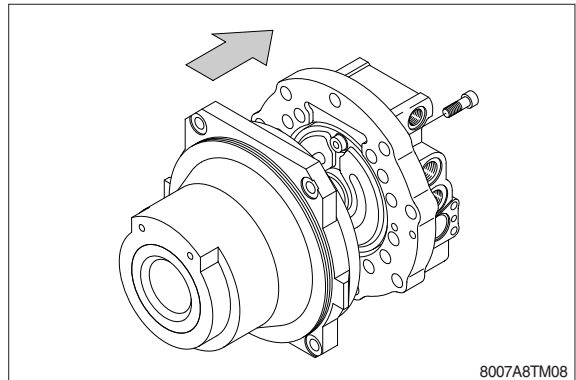

- ⑦ Remove valve plate (5) from base plate (1-2-1).

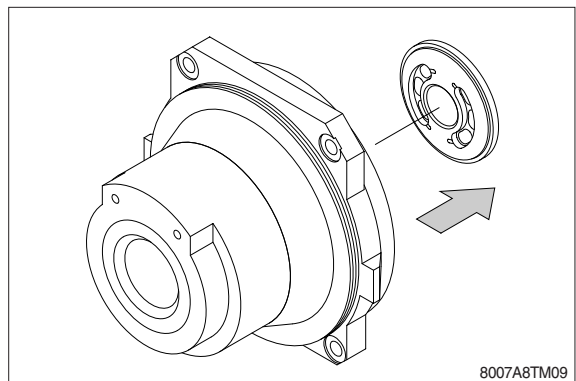

- ⑧ Remove O-rings (29)(30), pins (27) and springs (26).

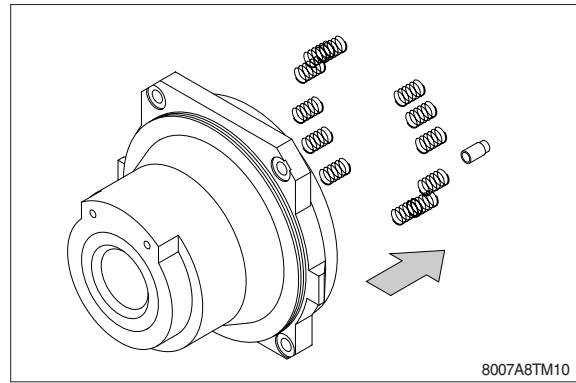

- ⑨ Remove brake piston (21).  
Blow compressed air into parking brake-releasing port on case (1).

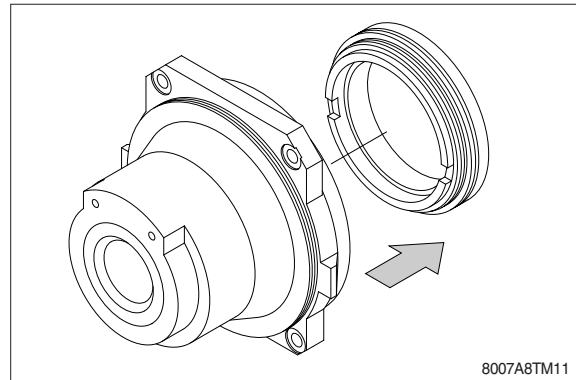

- ※ Before work, put rag on all surface of brake piston because brake piston fly out and oil flies off while at work.

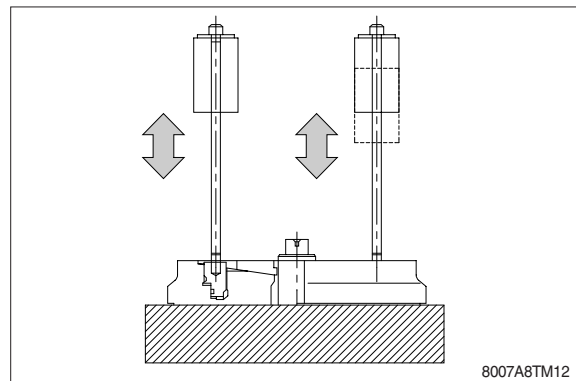

- ※ After removing brake piston, remove disk (19), friction plate (18)(20). And then, removing O-rings (22)(24) and back up rings (23)(25).

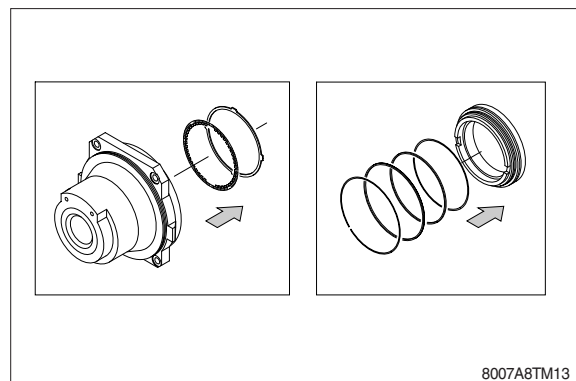

⑩ Remove cylinder block assy.

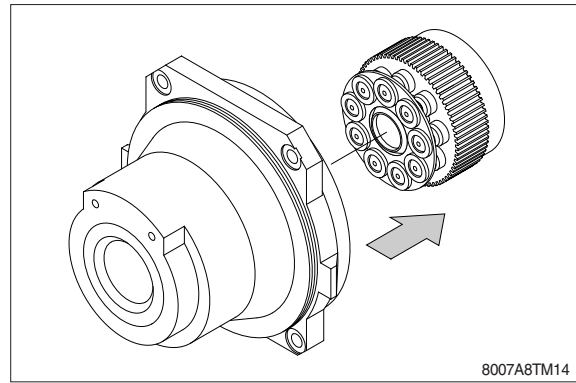

⑪ Disassemble cylinder block assy.

a: Remove piston assy (6) and retainer plate (7) from cylinder block (4).

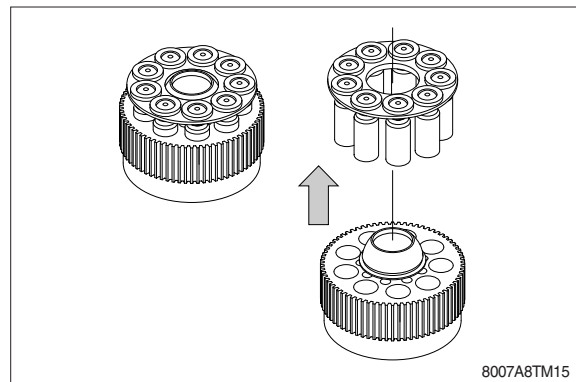

b: Remove piston assy (6) from retainer plate (7).

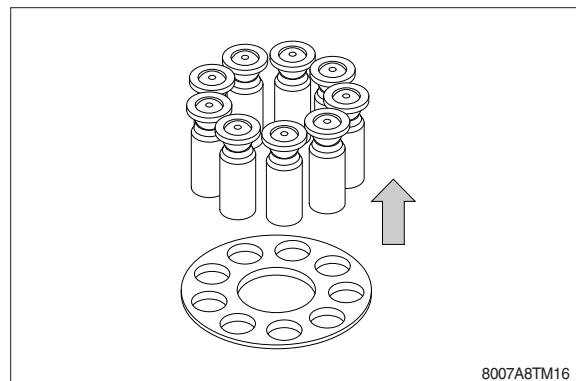

c: Remove retainer holder (8) from cylinder block (4).  
And then, remove springs (17) from cylinder block (4).

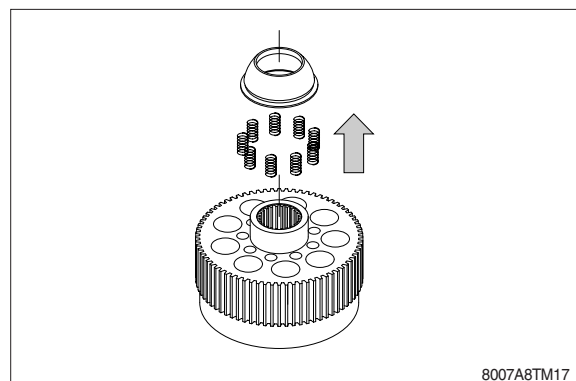

⑫ Remove swash plate (9).

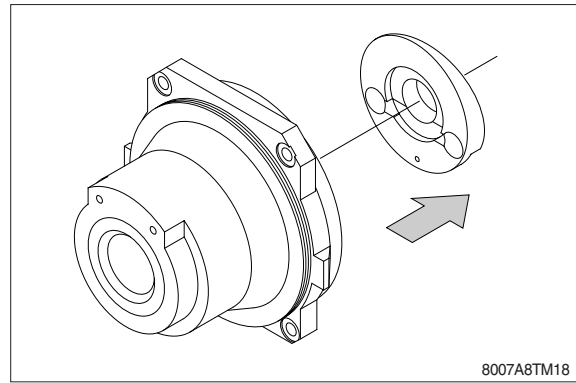

⑬ Remove piston assy (11) and spring (12).  
And then remove steel ball (10).

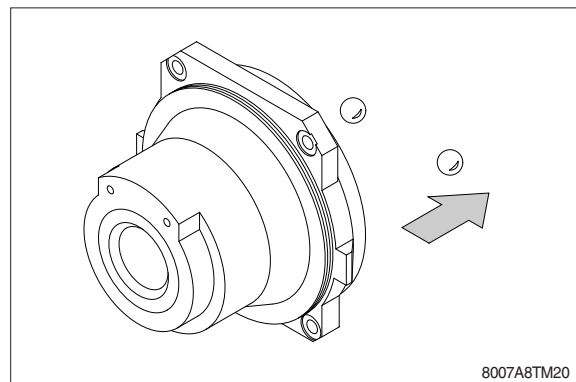
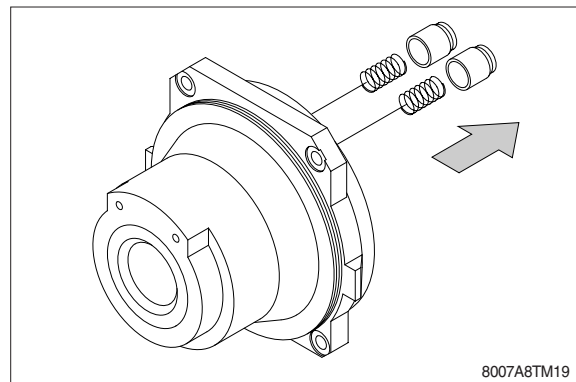

⑭ Remove shaft (3).

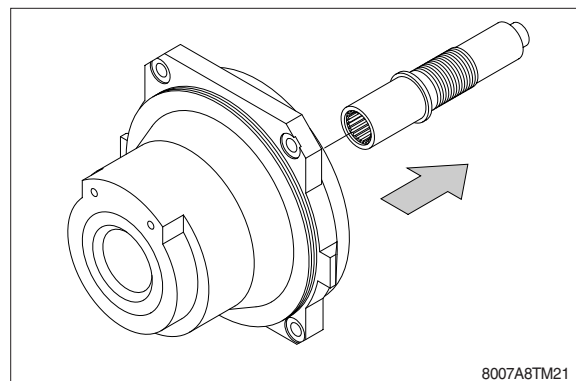



#### 4) REASSEMBLY

##### (1) General precautions

- ① Reassemble in a work area that is clean and free from dust and grit.
- ② Handle parts with bare hands to keep them free of liny contaminates.
- ③ Repair or replace the damaged parts.  
Each parts must be free of burrs its corners.
- ④ Do not reuse O-rings, oil seal and floating seal that were removed in disassembly.  
Provide the new parts.
- ⑤ Wash all parts thoroughly in a suitable solvent.  
Dry thoroughly with compressed air.  
Do not use the cloths.
- ⑥ When reassembling oil motor components of motor, be sure to coat the sliding parts of the motor and valve with fresh hydraulic oil. (NAS class 9 or above)
- ⑦ Use a torque wrench to tighten bolts and plugs, to the torque specified as follows.

- ① Apply grease to oil seal (28) and press fit it in case (1).

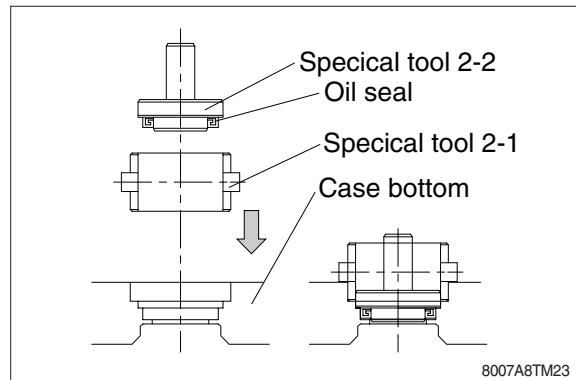
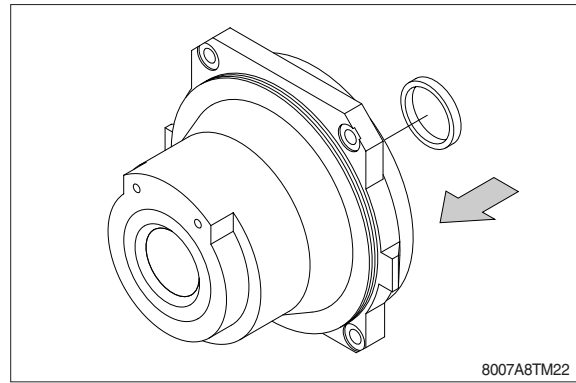

- ② Press fit the outer race of roller bearing (13) in case (1).

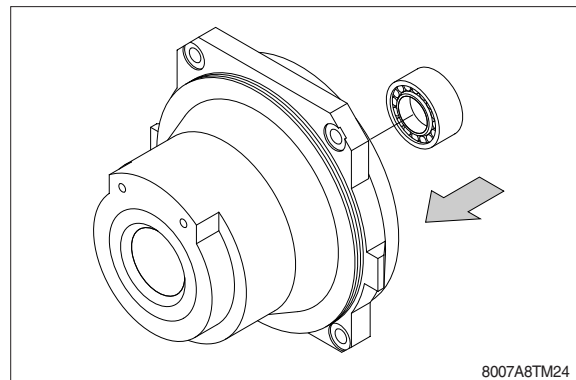

- ③ Install springs (12) and piston assy (11) on case (1).  
※ Apply hydraulic oil to the sliding surface of the piston assy.

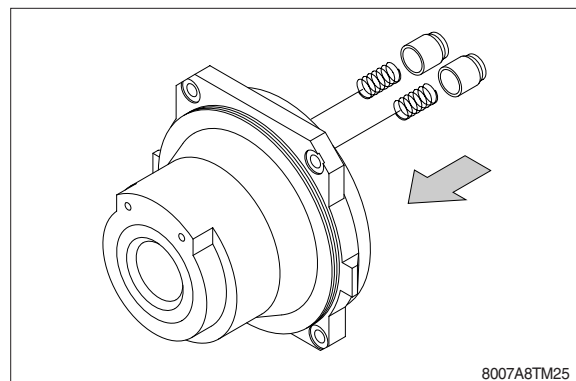

- ④ Install steel ball (10).  
※ Apply hydraulic oil to the surface of the steel ball.

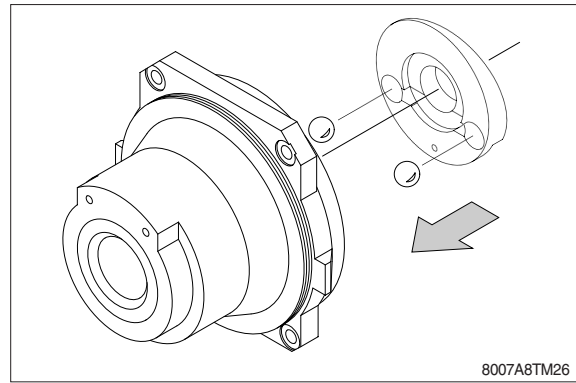

- ⑤ Press fit Inner race of roller bearing (13) on shaft (3).  
And then, install shaft sub assy on case (1).

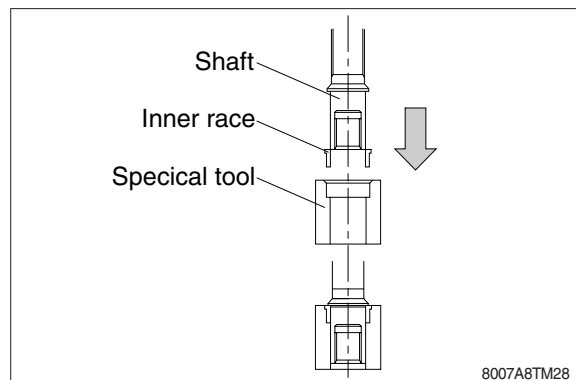
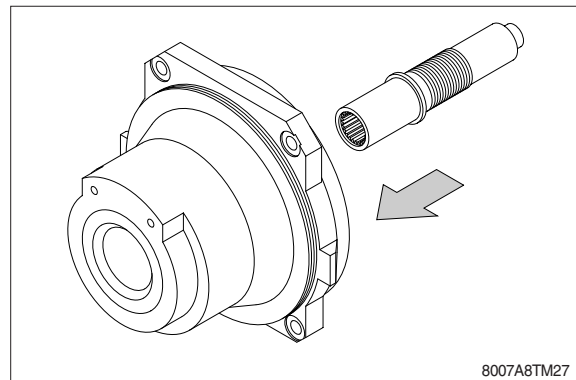

- ⑥ Install Swash plate (9).  
※ Apply hydraulic oil to the surface of the steel ball.

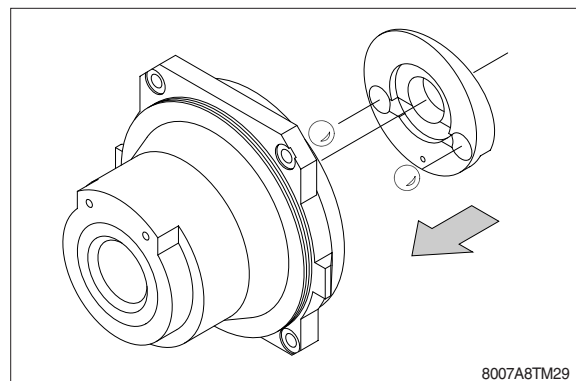

- ⑦ Install 9 springs (17) on cylinder block (4).

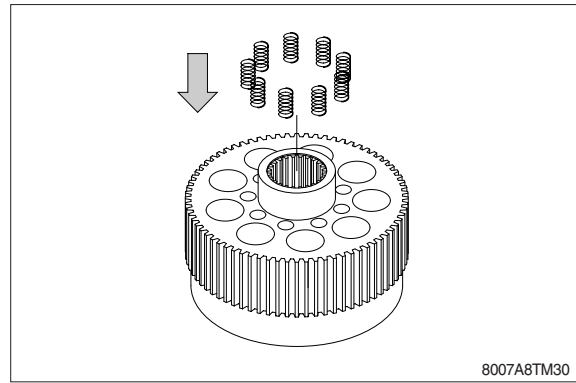

- ⑧ Install retainer holder (8) on cylinder block (4).

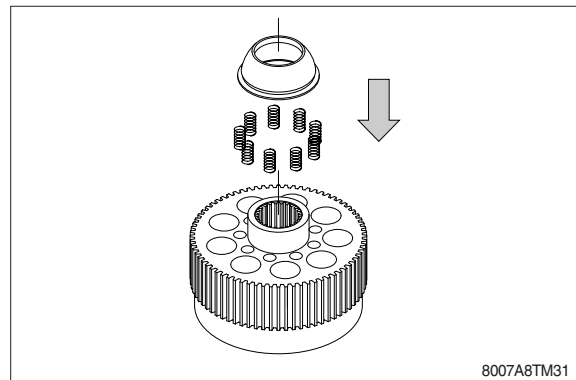

- ⑨ Install 9 piston assy (6) in each holes of retainer plate (7).  
※ Be care for the direction of the retainer plate.

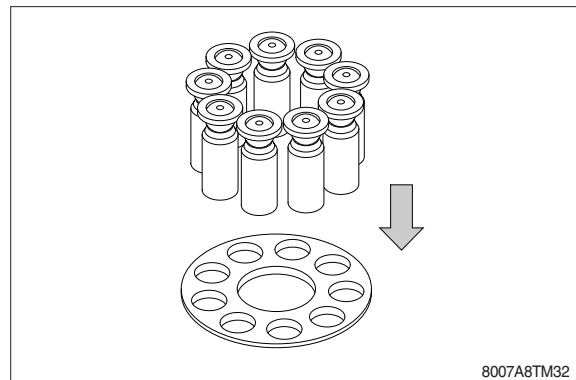

- ⑩ Install piston assy (6) and retainer plate (7) in cylinder block (4).  
※ Apply hydraulic oil in 9 holes of cylinder block.  
Apply hydraulic oil on the surface of retainer holder (8) and retainer plate (7).

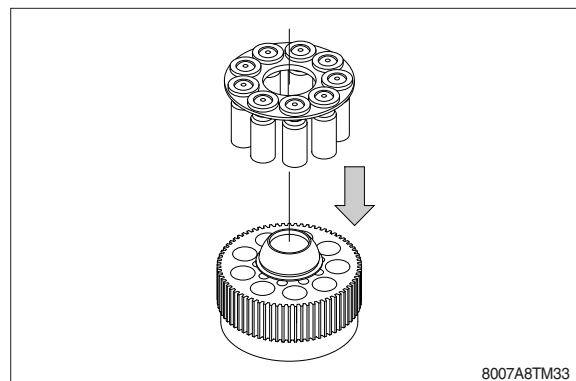

- ⑪ Install cylinder block assy.  
 ※ Apply hydraulic oil on the surface of piston assemblies (6) and swash plate (9).

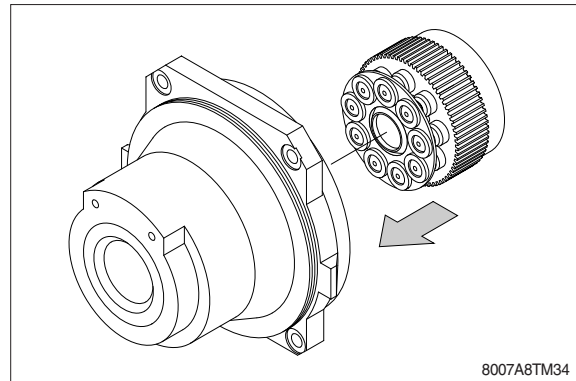

- ⑫ Install friction plates (18) and disk plates (19).  
 a: Apply enough hydraulic oil to disk plate.  
 b: The circular arc part of the friction plate is set to the cutting lack part of the case.  
 c: There is a part where teeth are lacked in the spline of disk plate.  
 When assembling the disk plates, match the position of these each parts.

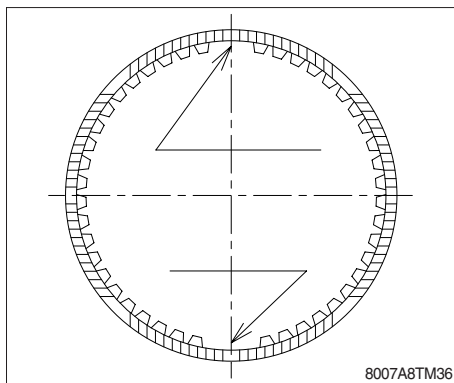
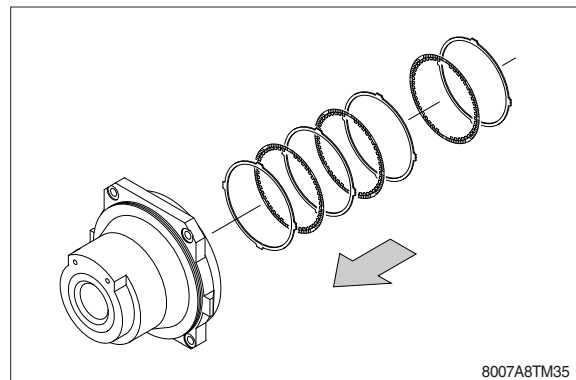

- d: Refer to the sectional drawing for the combination of assembling friction plate and disk plate.

⑬ Apply grease to O-rings (22)(24), backup ring (23)(25), and install them to brake piston (21).

And install brake piston (21) to case (1) to align pins (27) installed on base plate in No.\*\* with holes on brake piston (21).

When install it, beat on evenly outside of brake piston by using of plastic hammer.

a: Each backup rings should be set out side position.

b: Be careful of installing direction of brake piston.

c: Apply grease to outside of brake piston and inside of case (1).

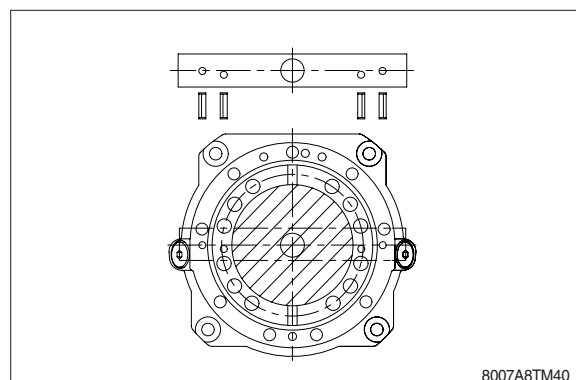
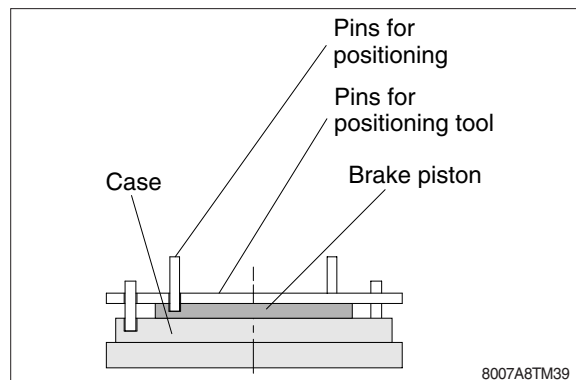
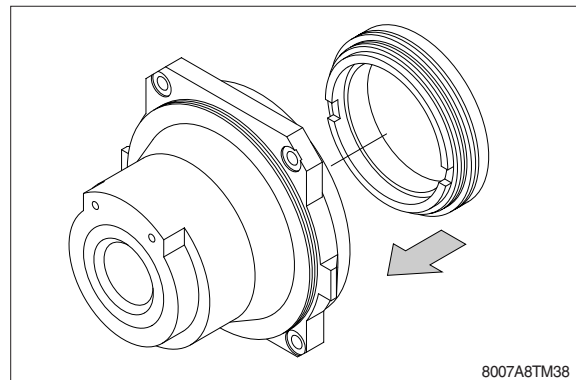
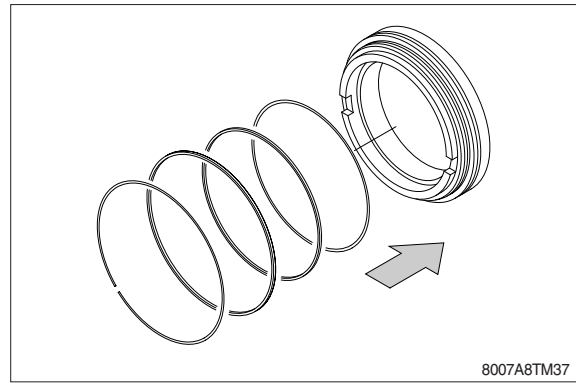

- ⑭ Install springs (26) in the holes of brake piston (21).

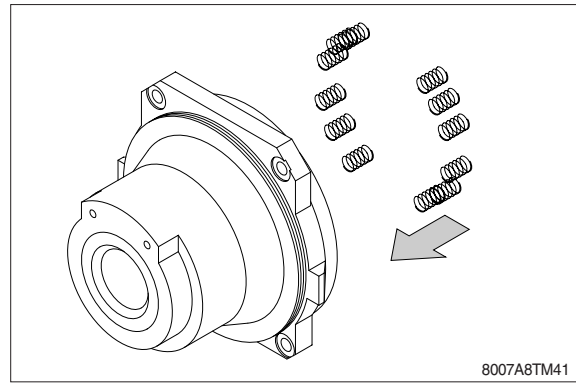

- ⑮ Press fit roller bearing (14) on base plate (2-1).  
Install pins (16) and color (15) on base plate (2-1).  
※ Apply grease to the surface of valve plate (25) and base plate (2-1).

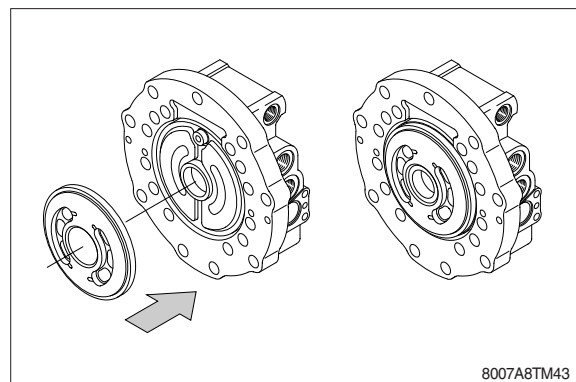
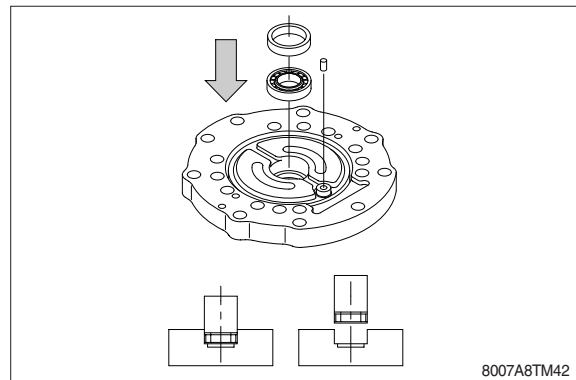

- ⑩ Install O-rings (29)(30) on case (1).  
 Install pins (27) on base plate (2-1).  
 Install base plate (2-1) and socket head bolt (9).
- a: Apply grease to O-ring (25).
  - b: Do not apply grease to O-ring (30).
  - c: Be care for direction of pin (27).
  - d: Apply hydraulic oil to the surface between cylinder block (4) and valve Plate (5).
  - e: Be care for pilot line of base plate and case (1).
  - f: Tighten the bolts evenly, as base plate is pushed by spring.

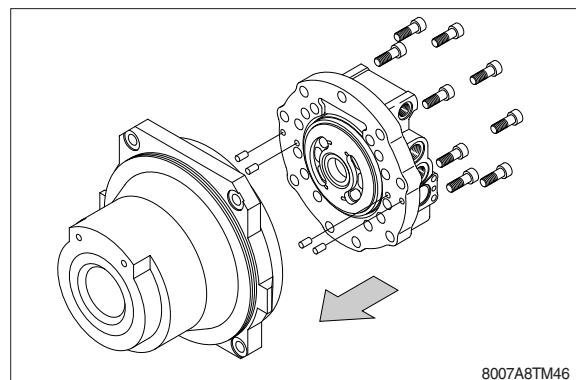
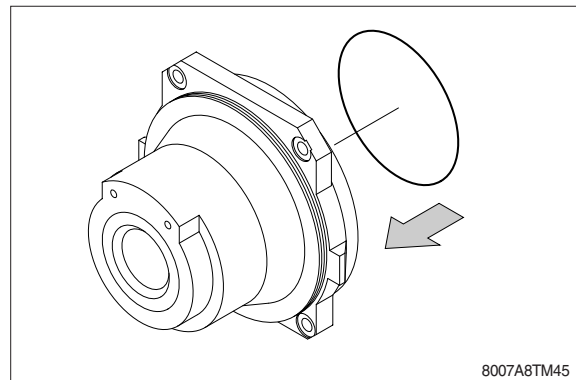
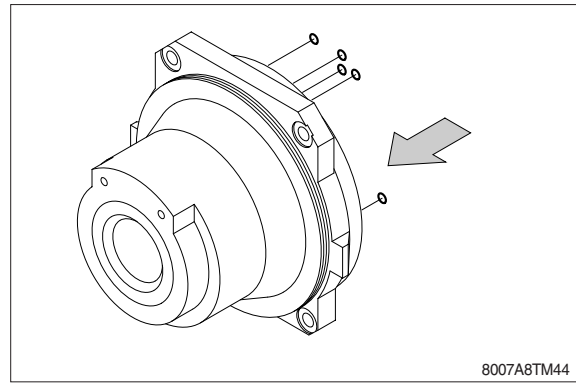

- ⑪ Place spring (2-13) on valve assy (2-9), and then install valve assy on base plate (2-1).  
 Tighten plug (2-14) with O-ring (2-15).  
 Place spring guide (2-16) and washer (2-18), and then tighten plug (2-17) with O-ring (2-15).
- ※ Apply hydraulic oil to valve assy before installation.  
 Apply slight grease to O-rings (2-15).

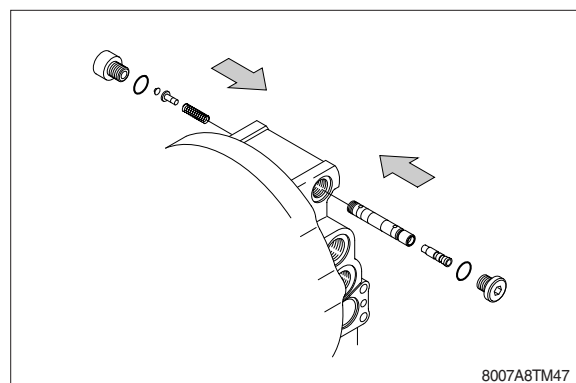



- ⑱ Tighten relief valve assemblies (2-7).  
※ Apply slight grease to O-rings (2-7-12)  
and backup rings (2-7-16).

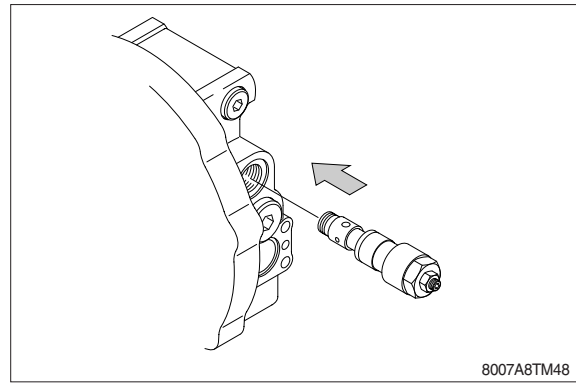

- ⑲ Place check valve (2-19) and springs (2-20).  
Tighten plug (2-21) with O-ring (2-22).  
※ Apply slight grease to the O-rings.

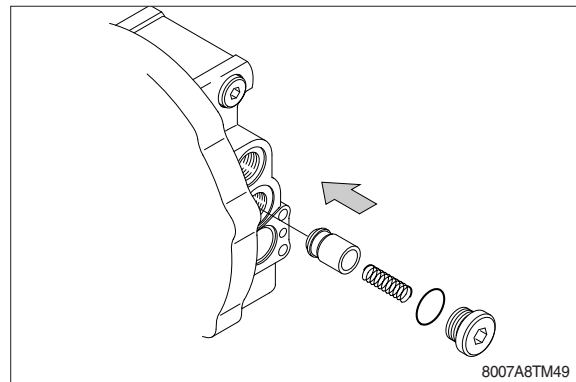

- ⑳ Install spool assy (2-2) on base plate (2-1).  
Install it while turning to prevent it from sticking.  
※ Apply hydraulic oil to spool assy before installation.

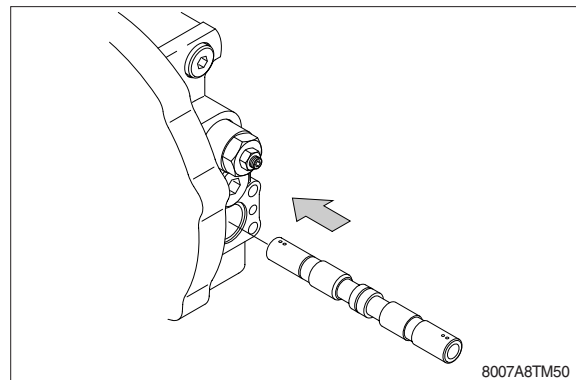

- ② Place spring seats (2-3) and springs (2-4).  
Install O-rings (2-10) on base plate (2-1).  
Install O-rings (2-6-5) on cap assy (2-6).  
Place spring seats (2-5) on cap assy (2-6), and then install them on base plate (2-1).  
※ Tighten socket head bolts (2-6-6).  
Apply grease to O-rings (2-6-5).

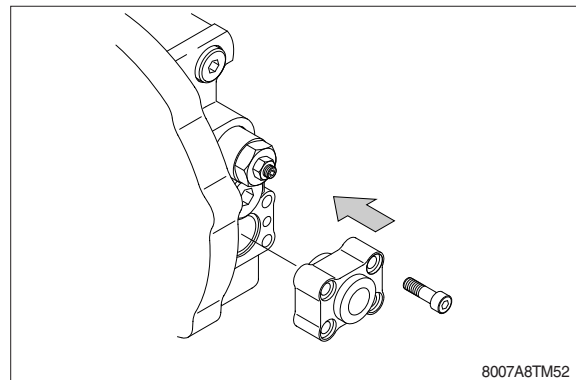
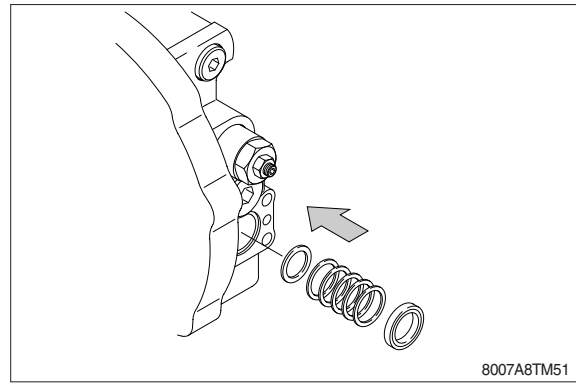



## 2) DISASSEMBLING

Initial inspection of the gears and the travel motor, can be made without disassembling the track and the gearmotor from the machine.

Prior to disassembling make sure that the oil is discharged, unscrew and remove the 4 screws (31), and remove the travel motor and the O-ring seal.

- (1) Unscrew the 12 socket head screws (30) and remove the motor flange from the adapter flange (29).

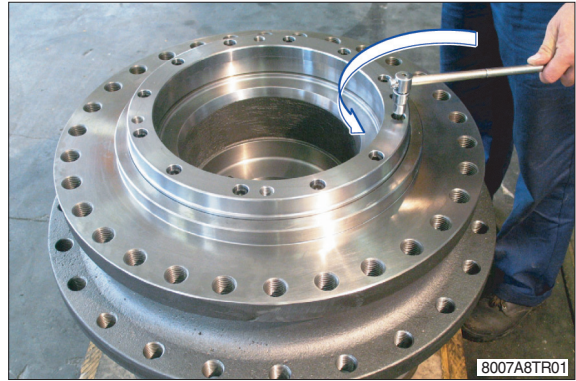

- (2) By using a tackle remove the motor adapter flange (29).

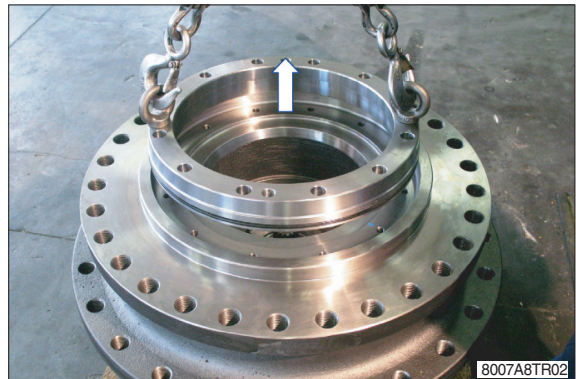

- (3) Remove the O-ring (28) from its seat in the motor adapter flange (29).



- (4) Assemble the equipment on the gearbox housing (22).

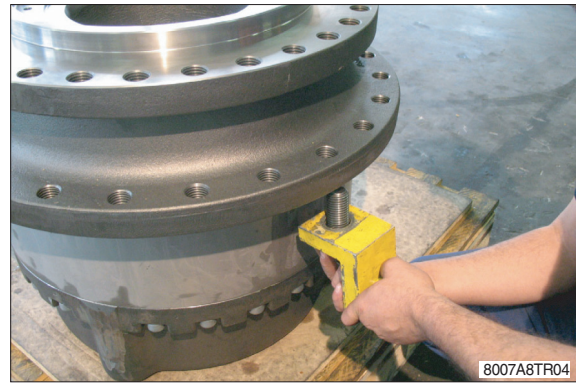

- (5) By using a tackle and the equipment turn the gearbox upside down.



- (6) Unscrew the 2 plugs (2) and the 2 washers (3) from the end cover (4).



- (7) Unscrew the 21 socket head screws (1) from the end cover (4).

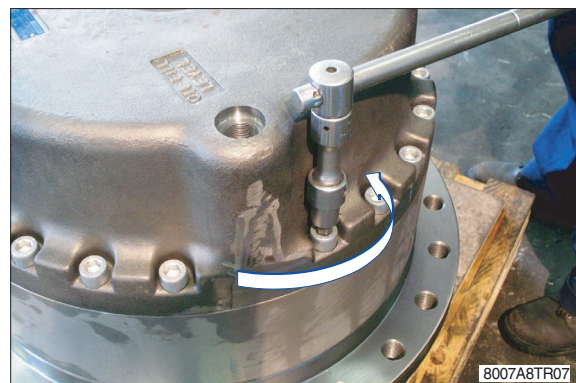



(8) By using a tackle and the equipment remove the end cover (4).

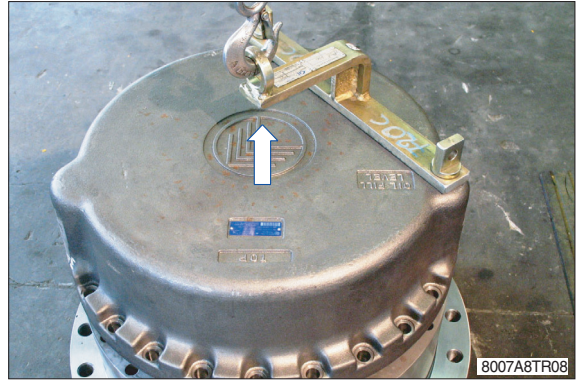

(9) Remove the O-ring (6) from its seat in the end cover (4).

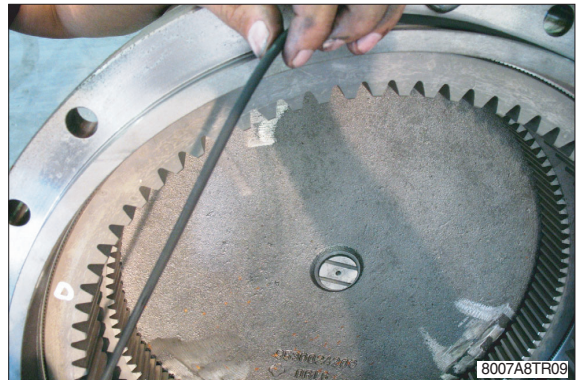

(10) Screw a socket head screw in the threaded hole of the pad (7) in order to remove it from the end cover (4).



(11) Remove the 1st stage sun gear (7).

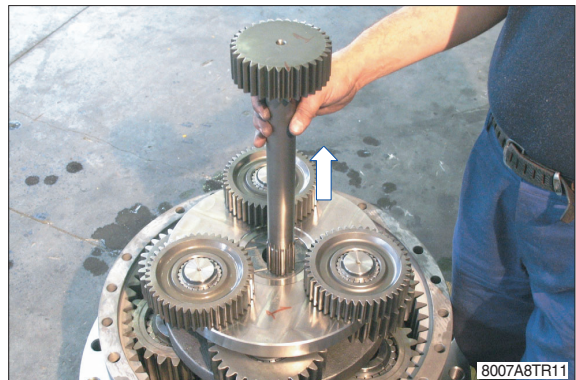

(12) Remove the centering ring.

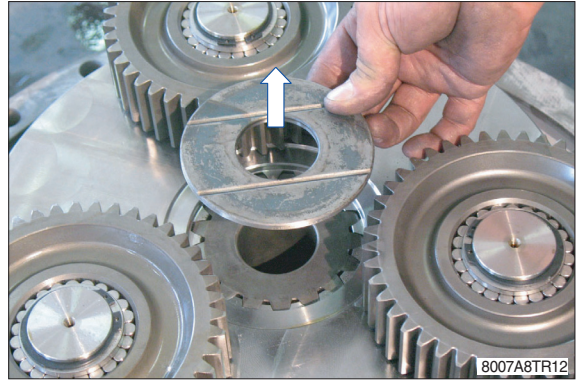

(13) By using a tackle and the equipment remove the 1st reduction assembly (8).

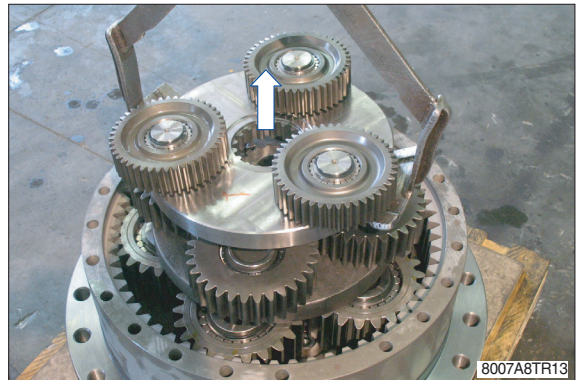

(14) Remove the 2nd stage sun gear (9).

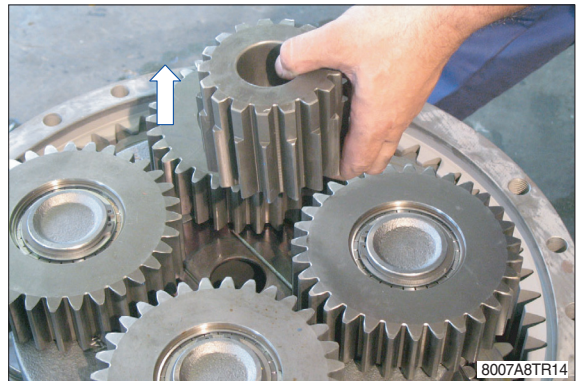

(15) By using a tackle and the equipment remove the 2nd reduction assembly (10).

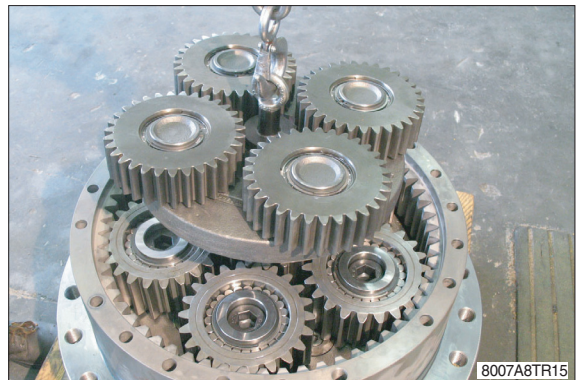



(16) Remove the 3rd stage sun gear (12).

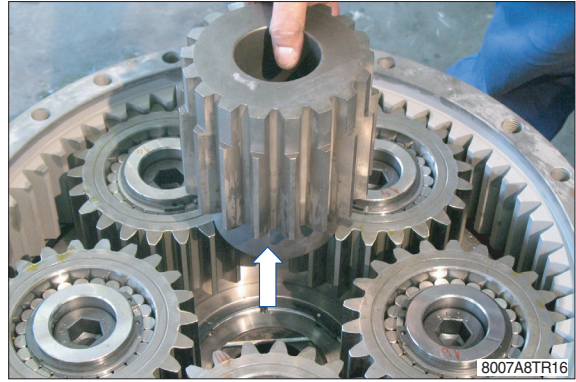

(17) By using a crowbar lift the toothed ring (19) from the gearbox housing (22).

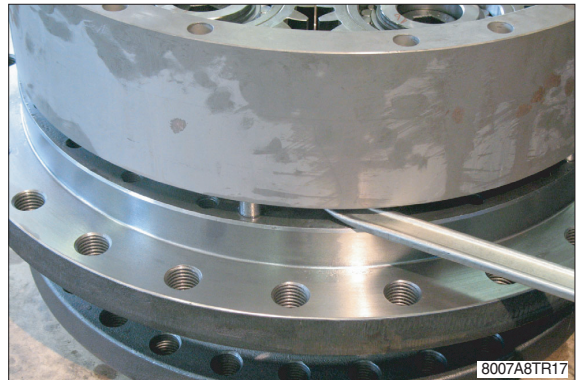

(18) Tighten 2 eyebolts on the toothed ring (19) and by using a tackle remove it from the gearbox housing (22).

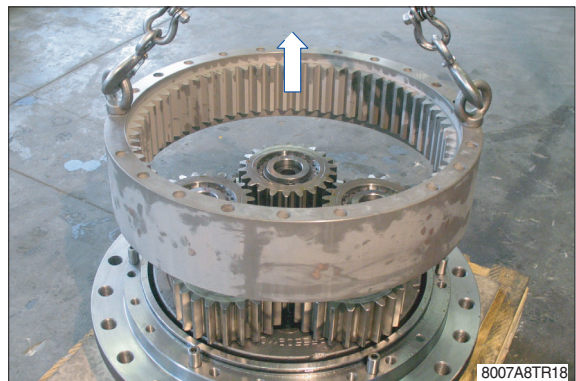

(19) By using the puller remove the 6 pins (20) from the gearbox housing (22).

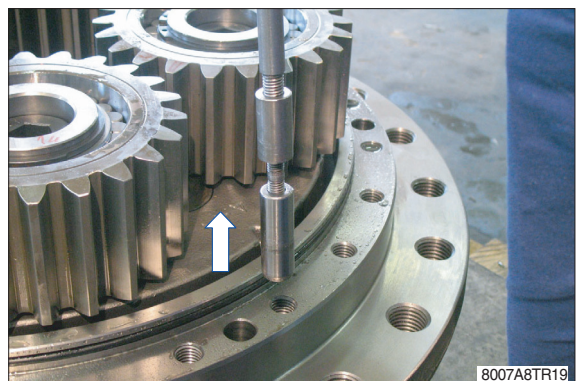



(20) Remove the O-ring (6) from its seat in the gearbox housing (22).

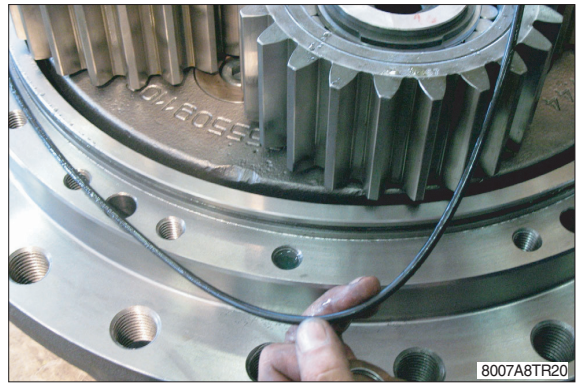

(21) By using pliers remove the circlips (13) from their seats placed in the planetary carrier's pins (16).

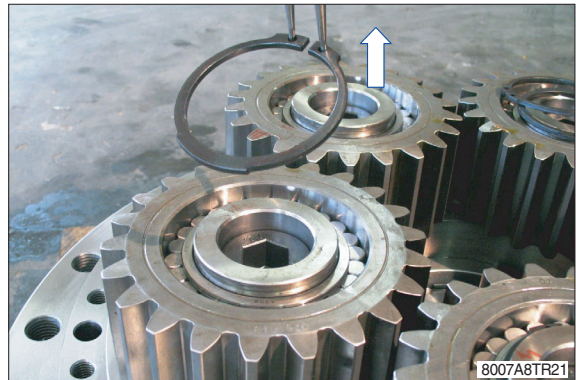

(22) By using a puller remove the planet assemblies of the 3rd reduction (14).

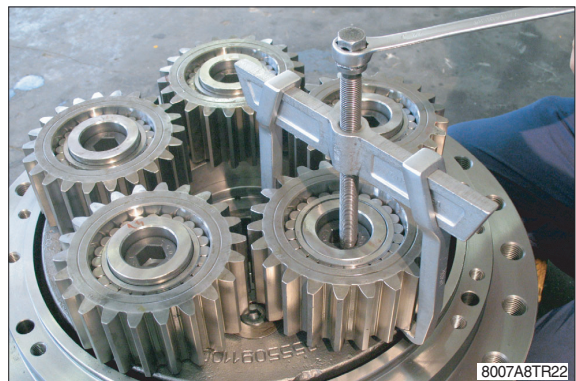

(23) Remove the planet assemblies of the 3rd reduction (14).

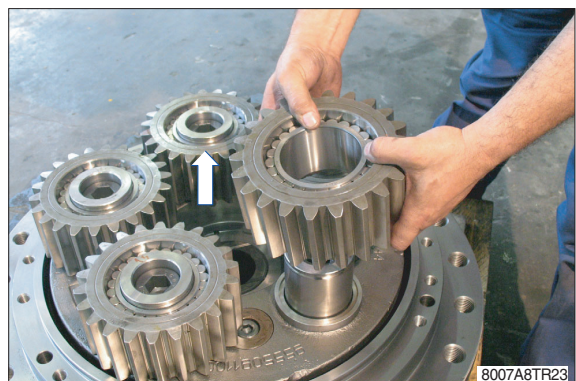

(24) Remove the spacer (15) from their seats placed in the planetary carrier's pins (16).

※ In order to proceed with the gearbox disassembly, it is now necessary to remove it from the machine and bring it to a properly equipped workshop.

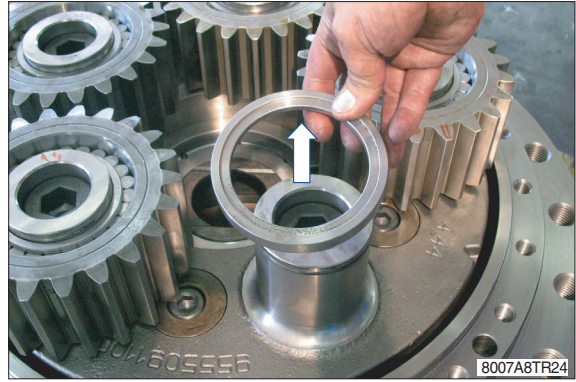

(25) By using a tackle palce the screwer on the planetary carrier's pins (16).

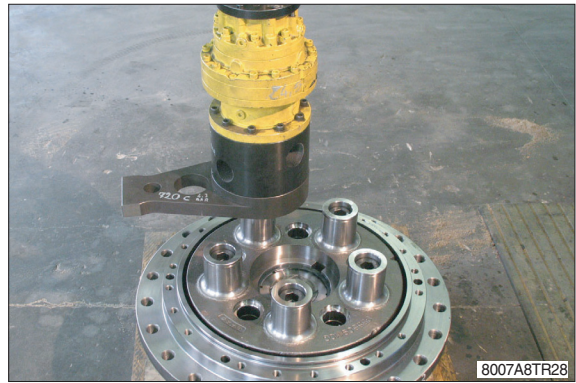

(26) By using the screwer tighten the 5 socket head screws (11) from the planetary carrier (16).



(27) Take out the nos. 5 socket head screws (11).

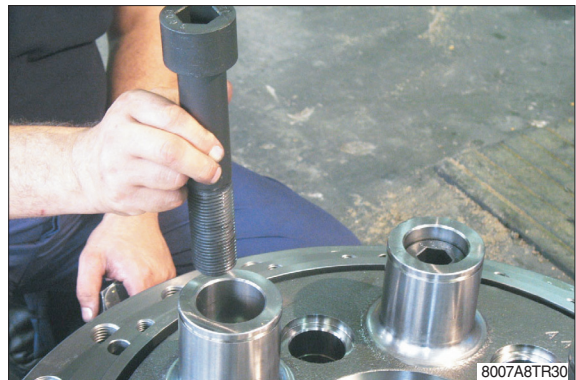



(28) By using a tackle remove the planetary carrier (16) from the gearbox housing (22).



(29) By using a screwdriver, remove the spacer (18) from the planetary carrier (16).

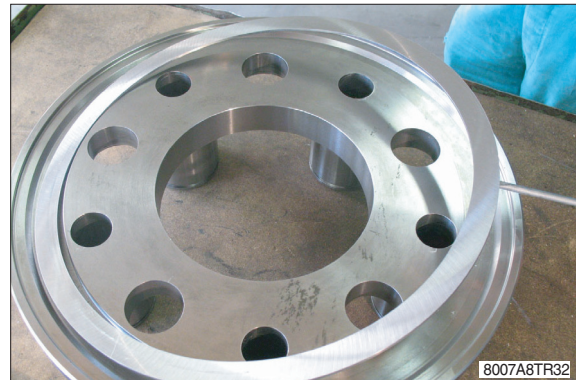

(30) By using a puller and a metal stopper remove the flanged hub (27) from the gearbox housing (22).

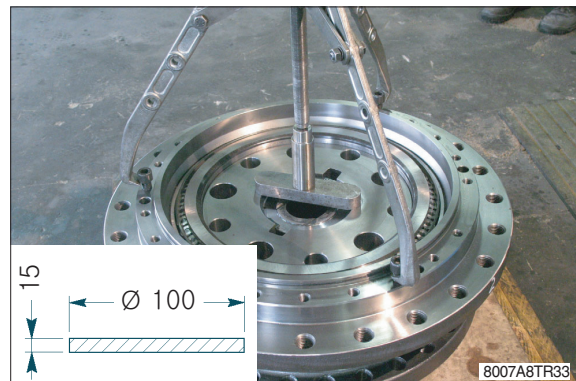

(31) Remove the bearing inner ring (21) from its seat in the gearbox housing (22).

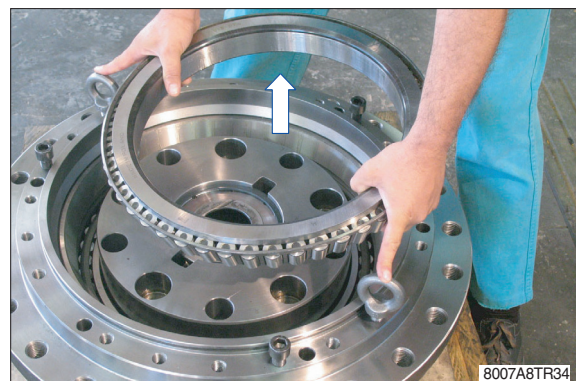

(32) Tighten 2 eyebolts on the gearbox housing (22) and by using a tackle remove it from the flanged hub (27).

※ In case of oil leakages, it might be necessary to check and eventually replace the lifetime seal (23), which means both the steel rings and the O-ring seals.

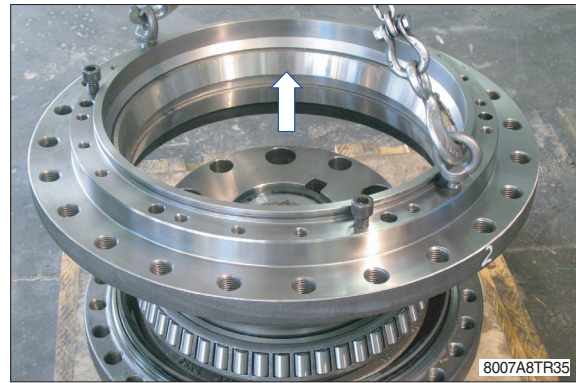

(33) Remove the half-seal (23) from the flanged hub (27).



(34) Remove the half-seal (23) from the gearbox housing (22).



(35) By using a puller remove the bearing inner ring (21), from the flanged hub (27).

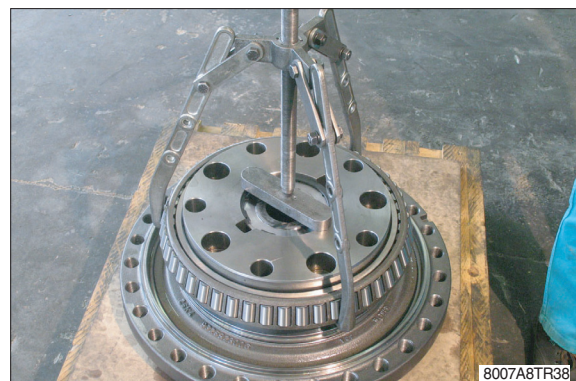



(36) Remove the spacer (24) from its seat in the flanged hub (27).



(37) By using pliers remove the circlip (25) from its seat in the flanged hub (27).

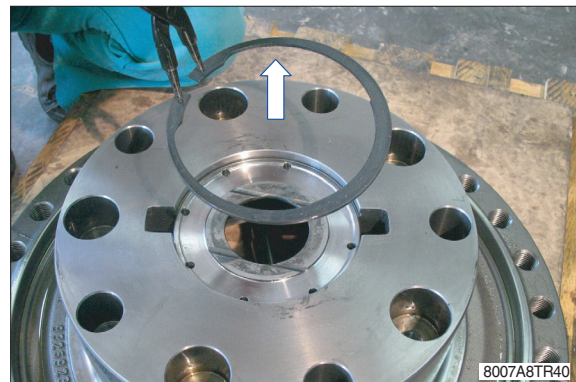

(38) By using a punch remove the discs retainer (26) from the flanged hub (27).



(39) By using a rubber hammer and a punch remove the bearing outer rings (21) from the gearbox housing (22).

※ The gearbox disassembly ends with the above operation. All the parts are now available for the necessary inspections.



## 1) REASSEMBLY

- ※ The pieces that are subject to general wear and tear are the following :
  - Gears
  - Bearings
  - All the seals
- ※ Replace the used or irregular parts respecting the following steps:
  - Accurately remove dirt, and in particular properly clean the seals, bearings and locking rings seating.
  - Lubricate the parts before connecting them.
  - In the case of damaged gears, for example a planetary, do not proceed to replace the individual gear but the entire reduction assembly.
  - When reconnecting a part always replace all the seals involved. Add some grease on the seats and on the new seals to make easier the reassembly.

- (1) Assemble the bearing inner ring (21) in the gearbox housing (22).

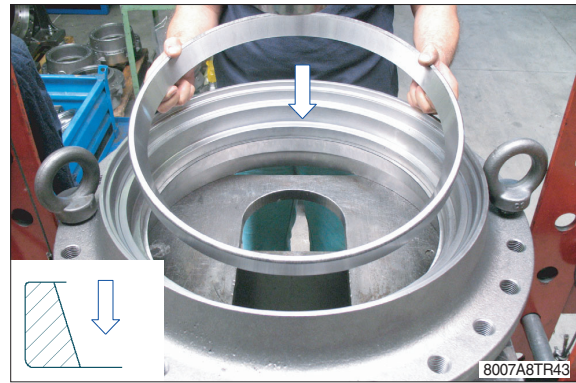

- (2) Place the equipment on the bearing outer ring (21).

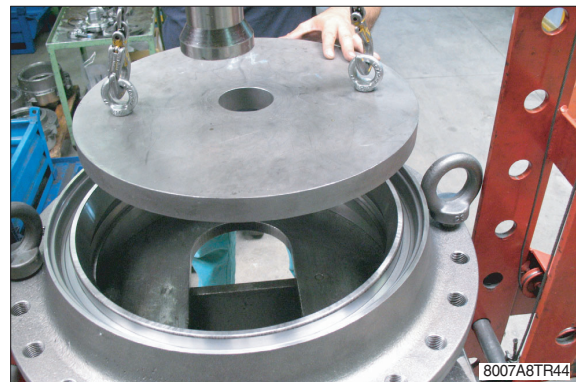

- (3) By using a press and the stopper push the bearing outer ring (21) against the gearbox housing shoulder (22).

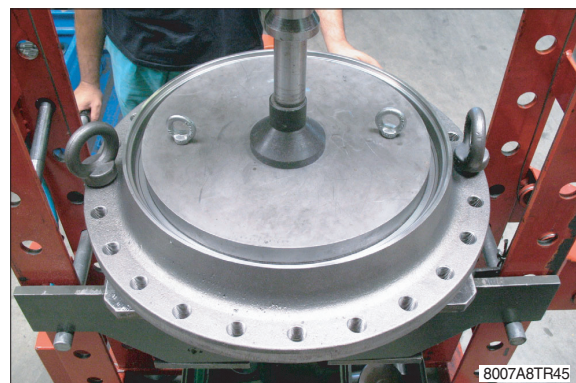

- (4) Insert the spacer (24) on the flanged hub (27).





※ **Make ready of the lifetime seal :**

- ① Carefully clean the **seats (A and B)** using, if necessary, metallic brushes or solvent (surfaces in contact with or (c) must be perfectly clean and dry).
- ② Make sure that **sealing surfaces (D)** of **metal rings (E)** are free from scratches, dinges or foreign substances; metallic ring surfaces must be perfectly clean and dry. We suggest to dip the metallic rings in volatile solvent or industrial degreasing alcohol.
- ③ Carefully clean the **lapped surface (D)** of **metal rings (E)** and remove dust or fingerprints. Then lubricate them with a thin oil film, taking care not to oil the other components.

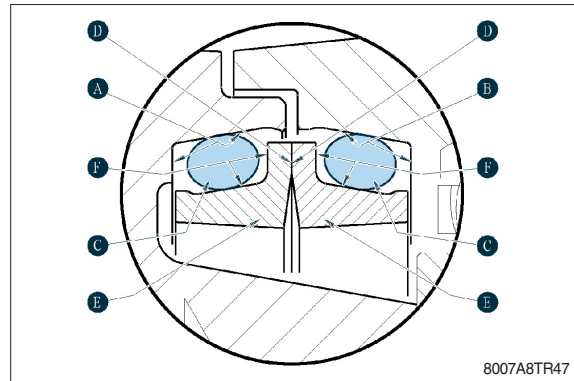

- (5) Assemble the half seal (23) on the tool.



- (6) Assemble the 1st half seal (23) in the flanged hub (27).





(7) Assemble the bearing inner ring (21) in the flanged hub (27).

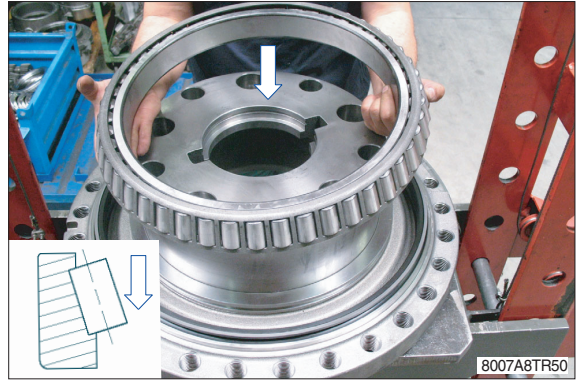

(8) Place the equipment on the bearing inner ring (21).

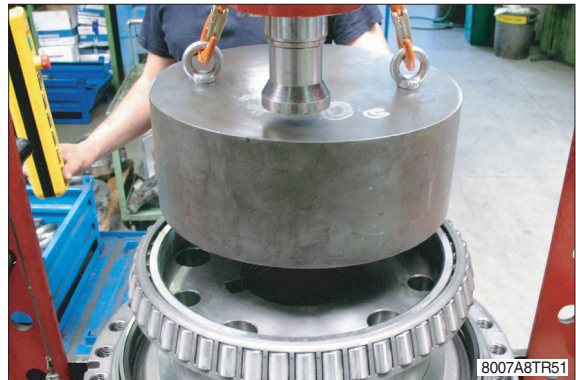

(9) By using a press and the stopper push the bearing inner ring (21) against the flanged hub shoulder (27).

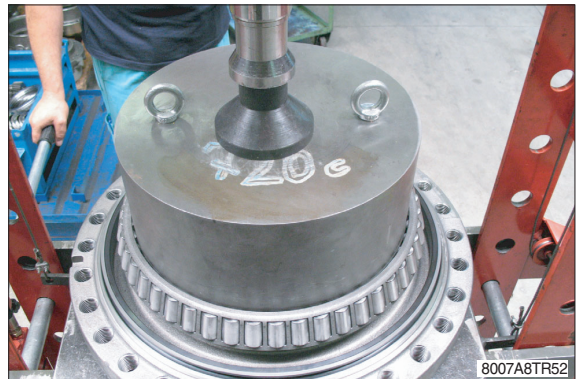

(10) Insert the 1st reduction assembly(8).



※ Correct lifetime seal assembly check (23).

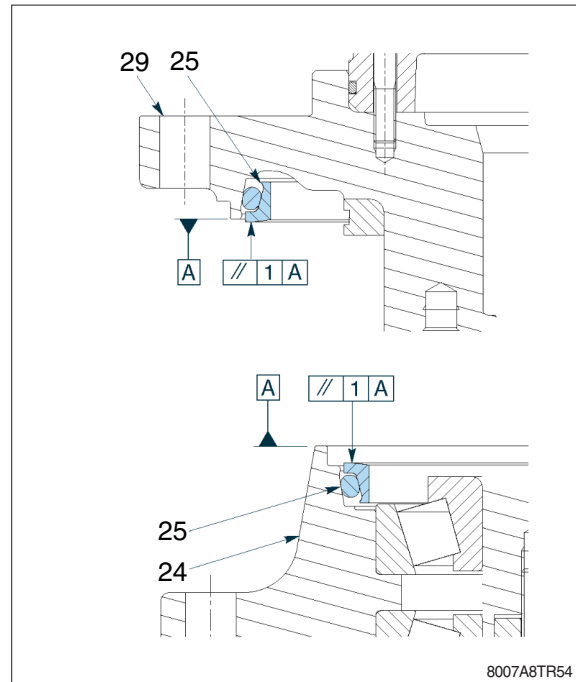

(11) Clean carefully the seal faces (23).

※ Apply a thin oil film on the entire metallic face of one or both seals. Oil must not contact surfaces other than the sealing faces.



(12) By using a tackle place the gearbox housing (22) on the flanged hub (27).

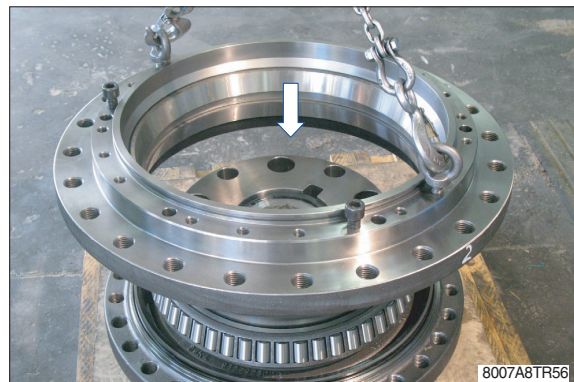

(13) Assemble the bearing inner ring (21) on the flanged hub (27).

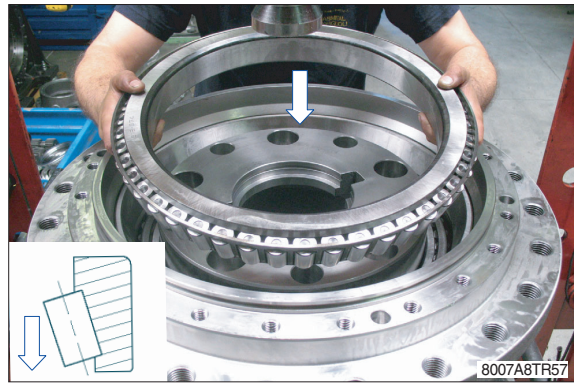

(14) Place the equipment on the bearing inner ring (21).

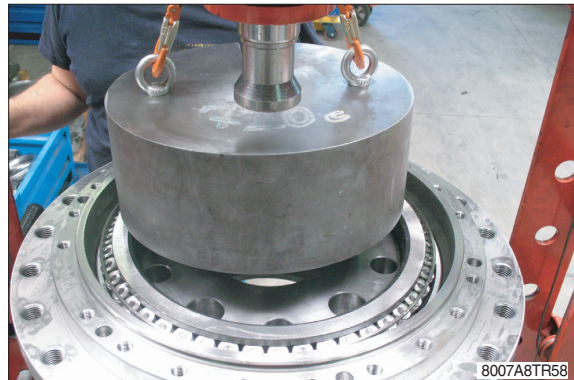

(15) By using a press and the stopper push the bearing inner ring (21) against the shoulder of the flanged hub (27) until assembling of the unit is complete.

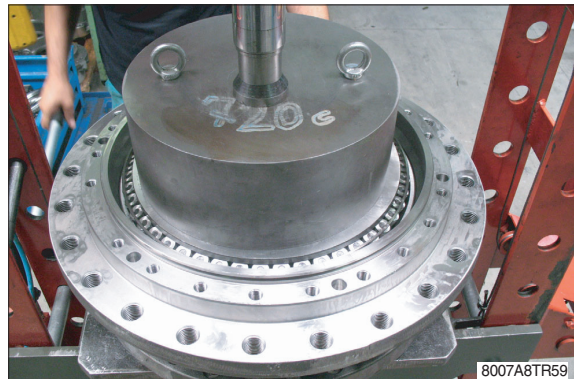

(16) By using a tackle remove the gearbox by the press.





(17) Place the discs retainer (26).

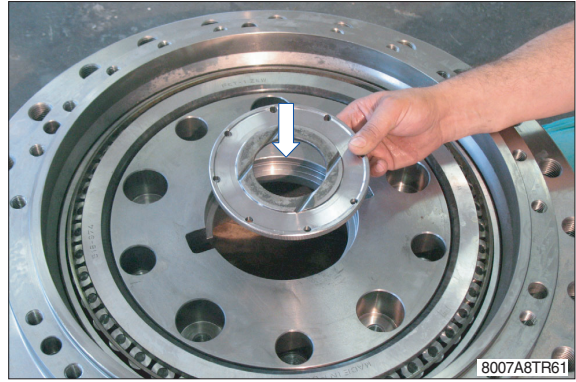

(18) By using a rubber hammer push the discs retainer (26) against the shoulder until assembly is complete.



(19) By using pliers assemble the circlip (13) into its seat on the flanged hub (27).

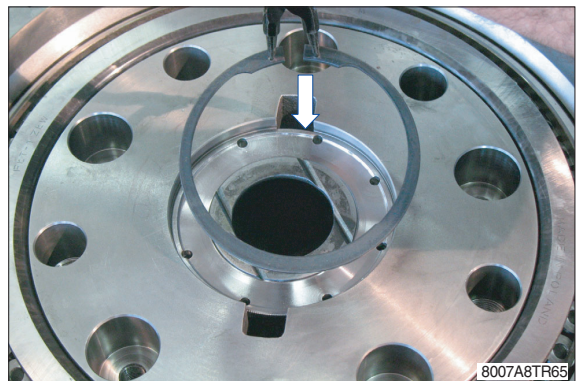

※ In case of bearings (21), gearbox housing (22) or flanged hub (27) replacing, follow the steps here below before proceeding with reassembling.

- ① Position the stopper on bearing (21).
- ② By using a press apply a load of 6120 kg (13500 lb) on the stopper.
- ③ Measure the control value "H"
- ④ Reduce the thickness "S" of the spacer (18) flattening the bearing areas at the following value;  

$$S = 10 - H - 0.1$$
- ⑤ Assemble the planet carrier (16) to the flanged hub (27) and by a dynamometric wrench find the necessary torque for the gearbox housing rotation (22).  

$$8.2 \sim 12.2 \text{ kgf} \cdot \text{m} (59.3 \sim 88.2 \text{ lbf} \cdot \text{ft})$$

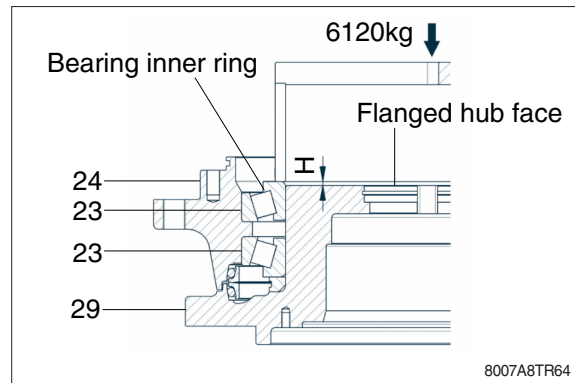

(20) Assemble the spacer (18) on the planetary carrier (16).



(21) By using a rubber hammer push the spacer (18) against the shoulder until assembly is complete.



(22) By using a tackle place the planetary carrier (16) on the flanged hub (27).

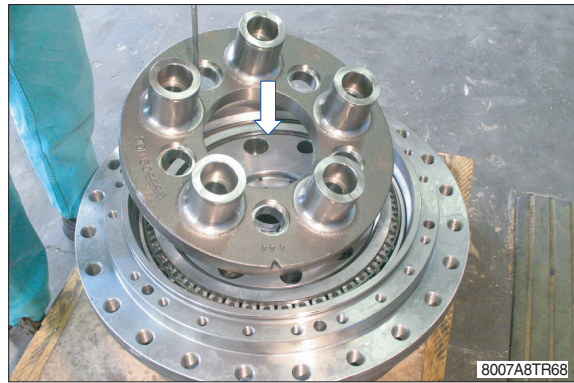

(23) Apply LOCTITE type 243 on the 5 socket head screws (11).

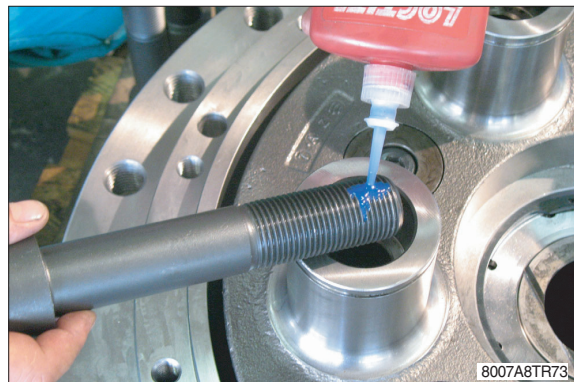

(24) By using a tackle place the screw on the planetary carrier's pins (16).



(25) By using the screw tighten the socket head screws (11), by a torque wrench with an input multiplier torque of  $6.7 \text{ kgf} \cdot \text{m}$  ( $48.5 \text{ lbf} \cdot \text{ft}$ ) corresponding to an output multiplier torque of  $342 \text{ kgf} \cdot \text{m}$  ( $2474 \text{ lbf} \cdot \text{ft}$ )





(26) Assemble the O-ring (6) into its seat in the gearbox housing (22).



(27) By using a rubber hammer push the 6 pins (20) against the shoulder until assembly is complete.

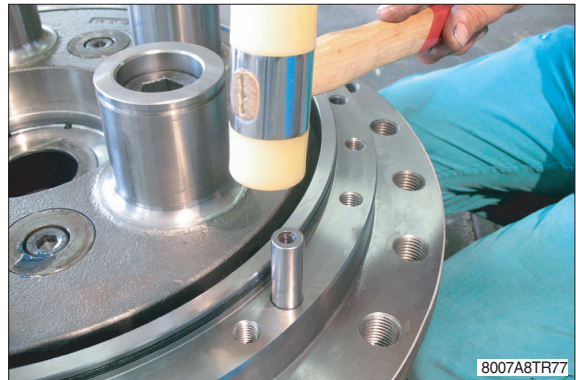

(28) By using a tackle assemble the toothed ring and, by using a rubber hammer, push it against the shoulder until assembly is complete.

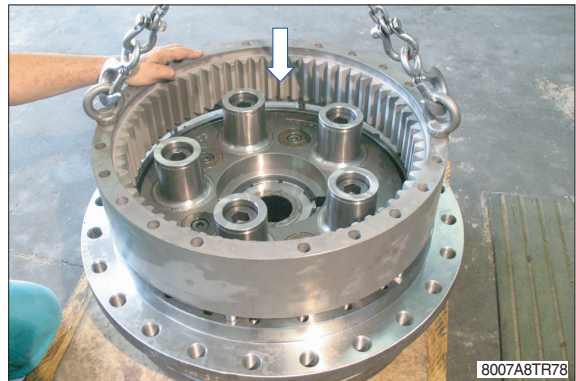

(29) Assemble correctly the spacers (15) on the pins of the planetary carrier (16).

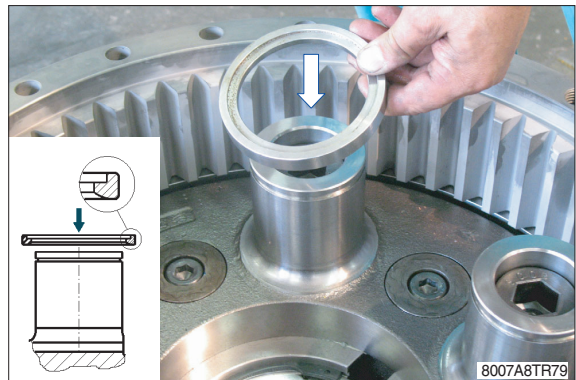

(30) Place the reduction planet assemblies of the 3rd reduction (14) on the pins of the planetary carrier (16).

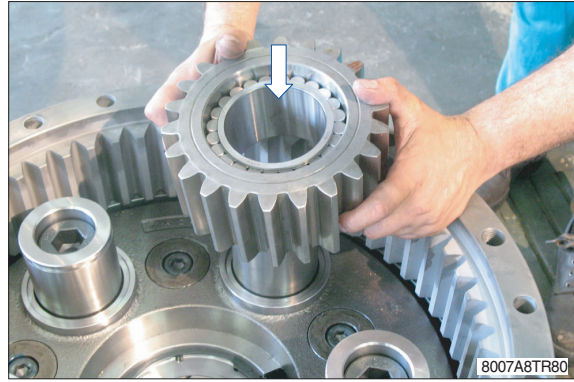

※ Place correctly the reduction planet assemblies checking that the groove is towards the end cover.

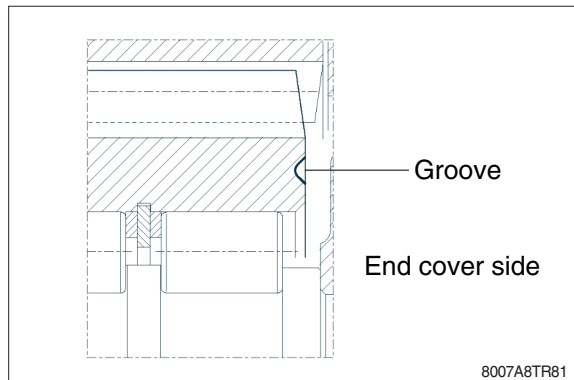

(31) By using a stopper and a rubber hammer push the planet assemblies of the 3rd reduction (14) against the shoulder until assembly is complete.

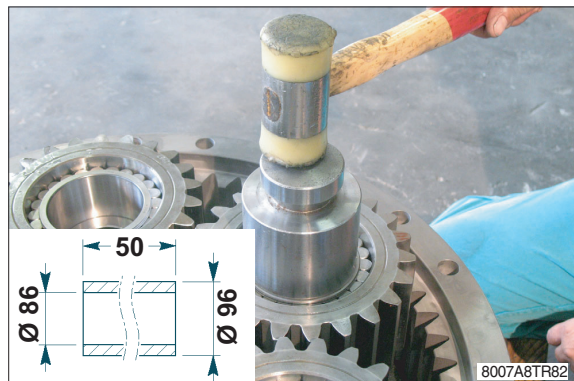

(32) By using pliers, assemble the circlips (13) in the planetary carrier pin seats (16).





(33) Insert the 3rd stage sun gear (12).

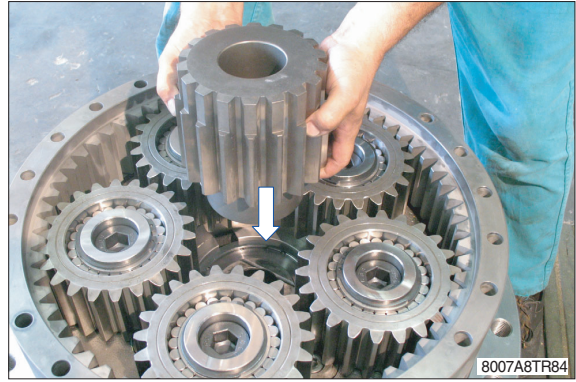

(34) By using a tackle and the equipment assemble the 2nd reduction assembly (10).

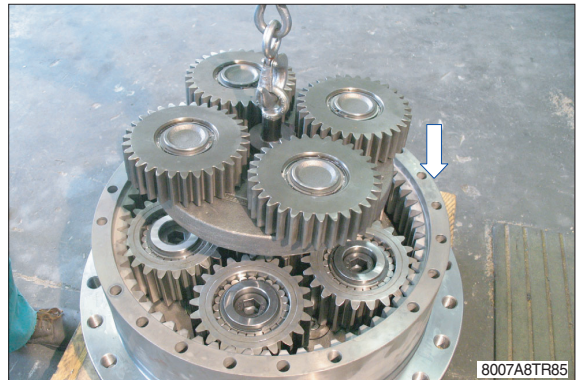

(35) Insert the 2nd stage sun gear (9).



(36) By using a tackle and the equipment assemble the 1st reduction assembly (8).

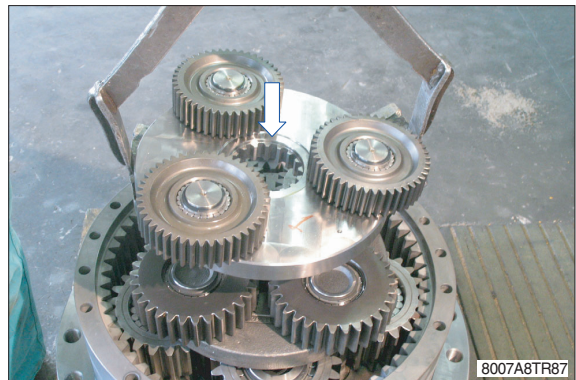

(37) Assemble the centering ring.

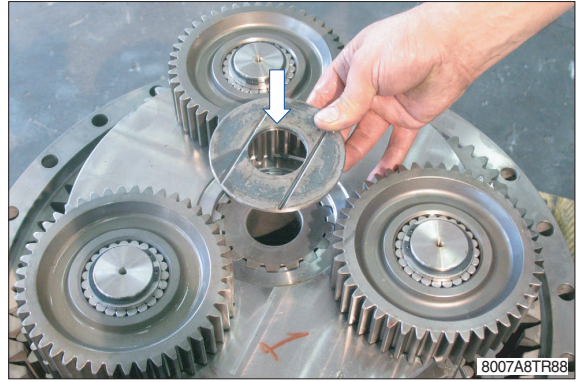

(38) Insert the 1st stage sun gear (7).

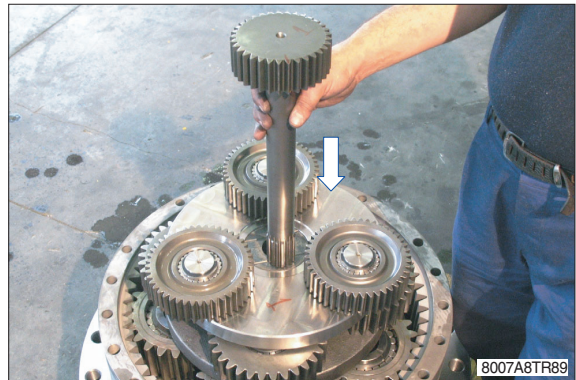

(39) By using a punch and a rubber hammer press the pad (5) against the shoulder of the end cover (4).



(40) Assemble the O-ring (6) into its seat in the end cover (4).

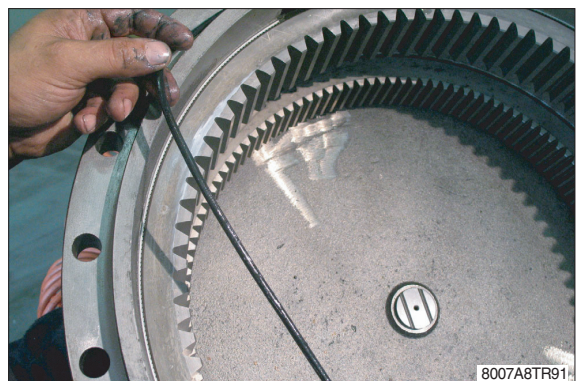



(41) By using a tackle and the equipment place the end cover (4) on the toothed ring (19).

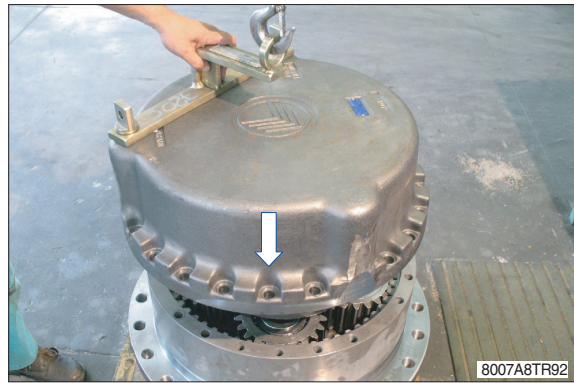

(42) Tighten the 21 socket head screws (1) by a torque wrench at  $48.9 \text{ kgf} \cdot \text{m}$  ( $354 \text{ lbf} \cdot \text{ft}$ ) torque.

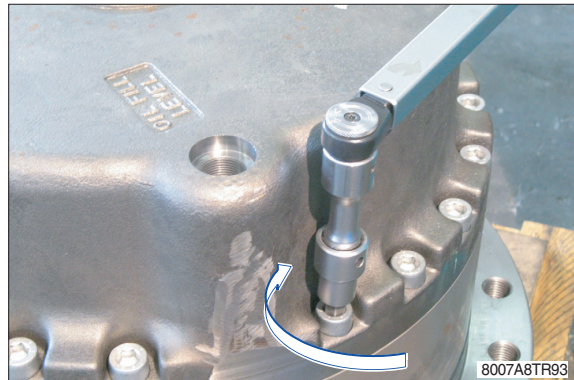

(43) Insert the washers (3) and the plugs (2) into the oil draining-filling holes of the end cover (4). Tighten the plugs by a torque wrench at  $7.1 \pm 1.0 \text{ kgf} \cdot \text{m}$  ( $51.4 \pm 7.2 \text{ lbf} \cdot \text{ft}$ ) torque.



(44) By using a tackle and the equipment turn the gearbox upside down.



(45) Assemble the O-ring (28) into its seat in the motor adapter flange (29).

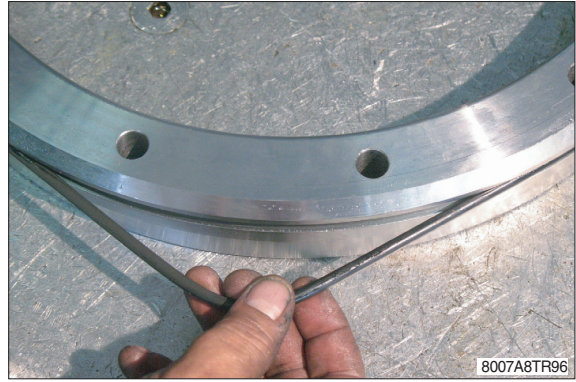

(46) Position the motor adapter flange (29) on the gearbox.

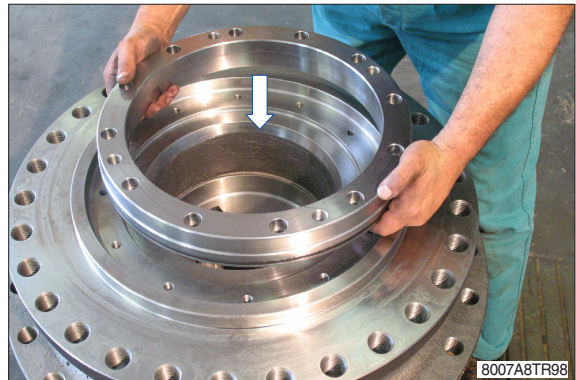

(47) Tighten the 12 socket head screws (30) by a torque wrench torque.

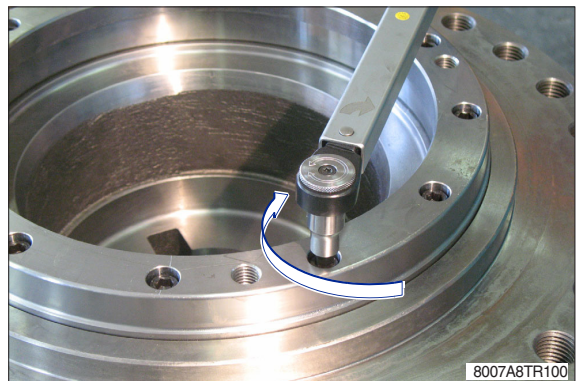

※ Before assembling the hydraulic motor, verify by a depth slide gauge the correct assembly of the unit checking the axial distance as shown in the scheme.

