

GROUP 4 HYDRAULIC SYSTEM

HYDRAULIC COMPONENTS MOUNTING 1

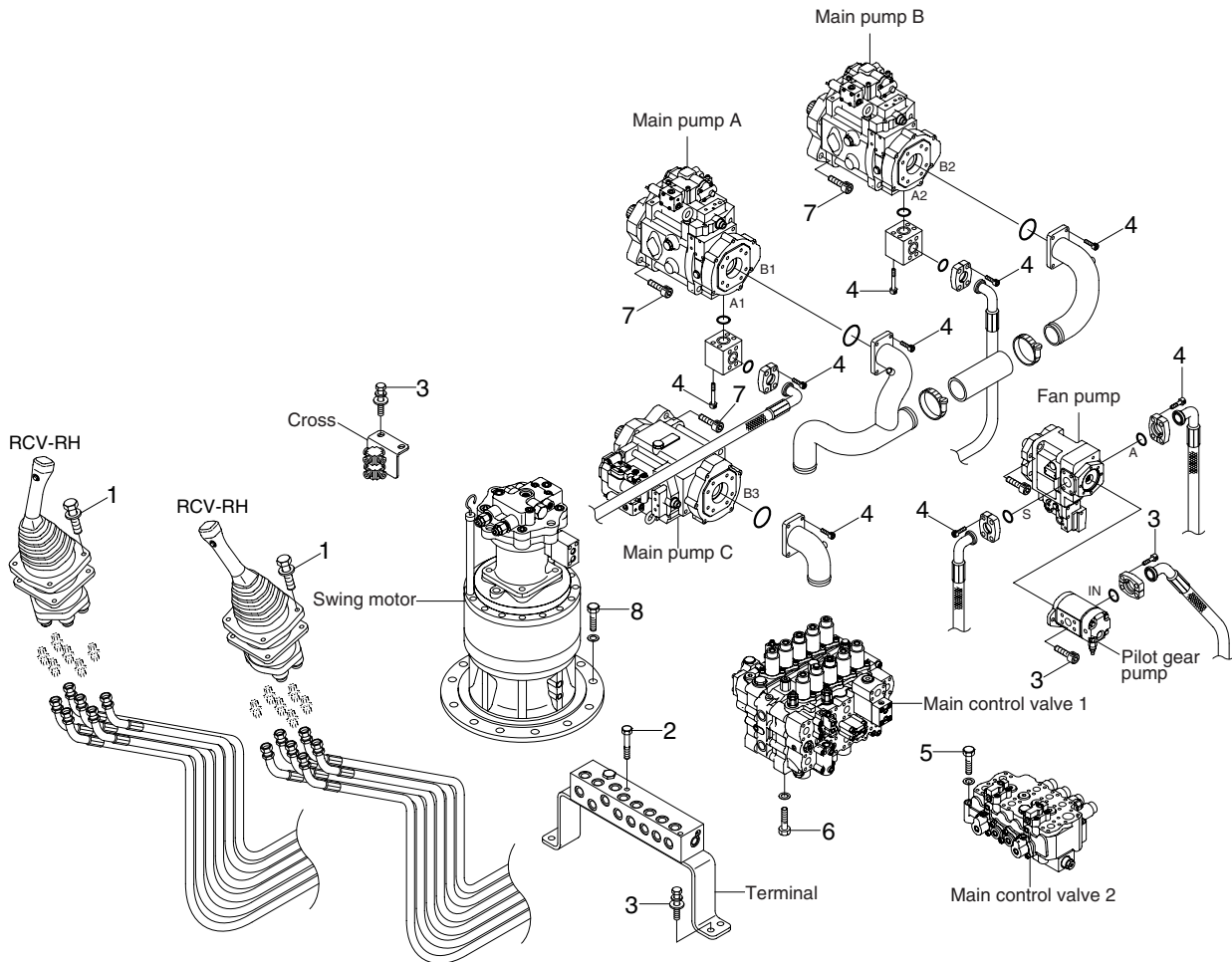

120099CM06

· Tightening torque

Item	Size	kgf · m	lbf · ft
1	M 6 × 1.0	1.05 ± 0.2	7.6 ± 1.45
2	M 8 × 1.25	2.5 ± 0.5	18.1 ± 3.6
3	M10 × 1.5	6.9 ± 1.4	49.9 ± 10.1
4	M12 × 1.75	12.3 ± 1.3	88.2 ± 9.4

Item	Size	kgf · m	lbf · ft
5	M16 × 2.0	29.7 ± 4.4	215 ± 31.8
6	M20 × 2.5	42.6 ± 4.2	308 ± 30.3
7	M20 × 2.5	57.9 ± 8.7	419 ± 62.9
8	M24 × 3.0	100 ± 15	723 ± 108

HYDRAULIC COMPONENTS MOUNTING 2

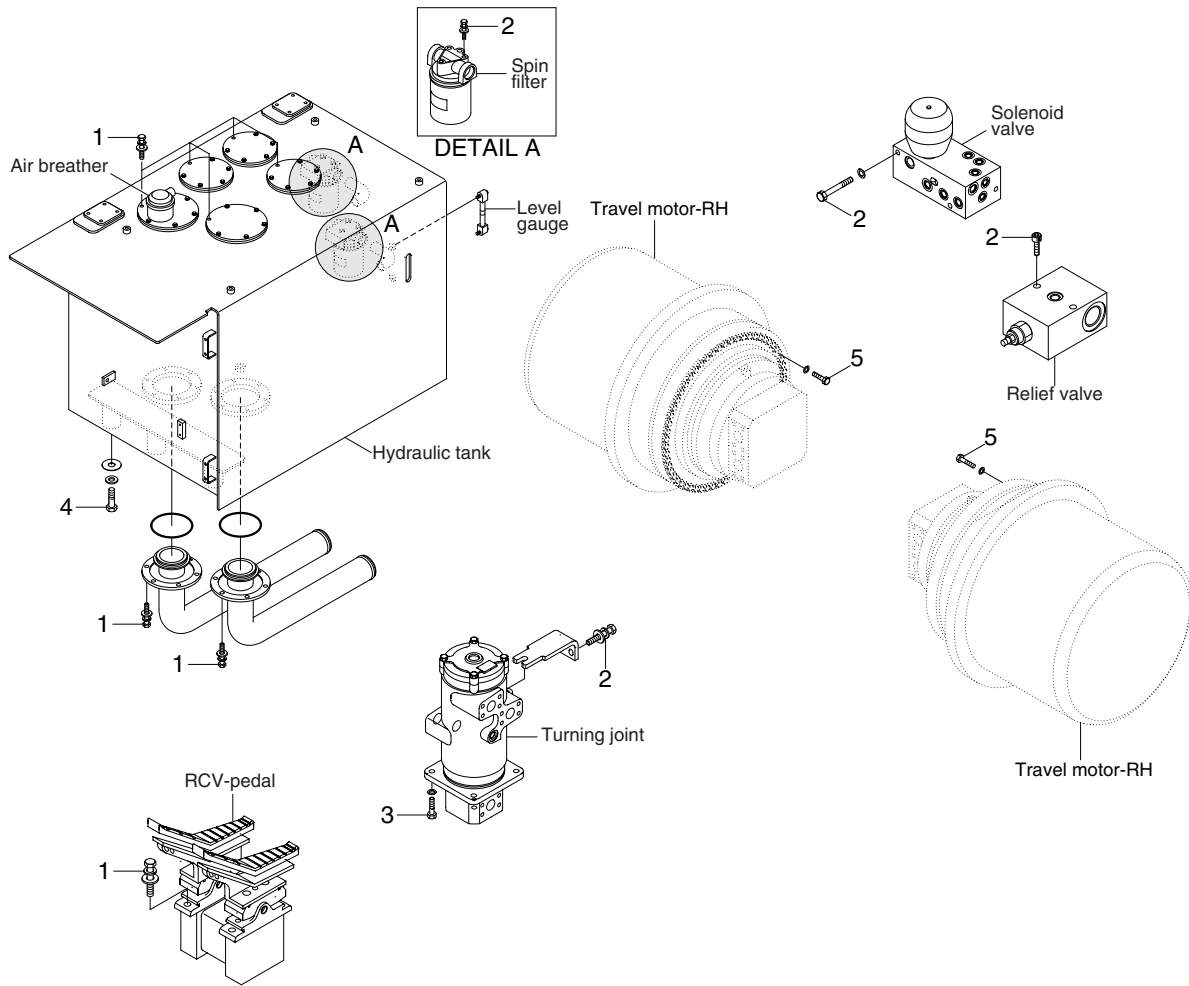

120099CM17

· Tightening torque

Item	Size	kgf · m	lbf · ft
1	M10×1.5	6.9±1.4	49.9±10.1
2	M12×1.75	12.8±3.0	92.6±21.7
3	M16×2.0	29.7±4.5	215±32.5

Item	Size	kgf · m	lbf · ft
4	M20×2.5	57.9±8.7	419±62.9
5	M30×3.5	150±10	1085±72.3

HYDRAULIC COMPONENTS MOUNTING 3

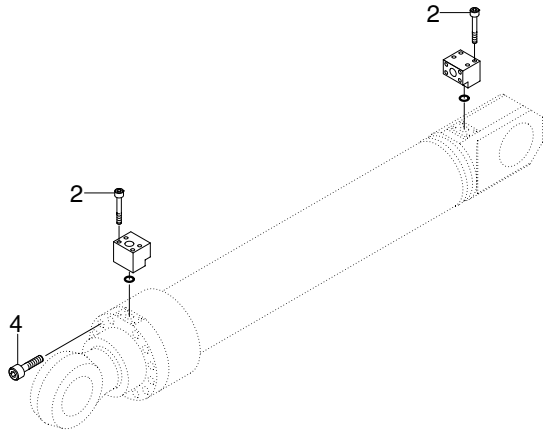

BOOM CYLINDER

Solenoid valve

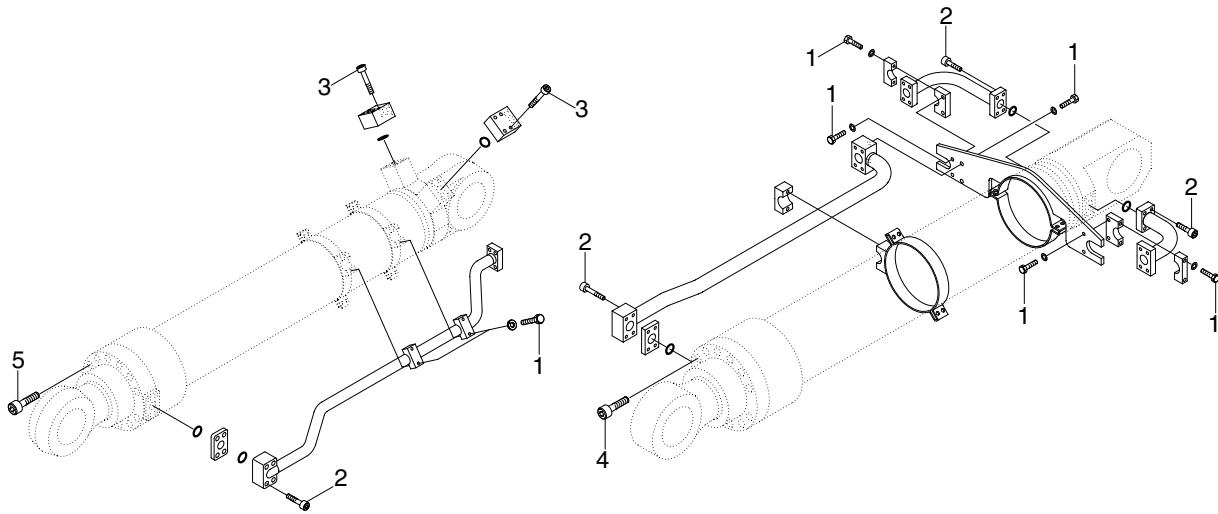
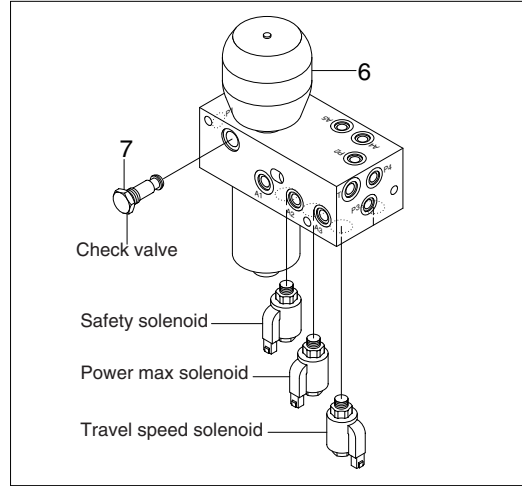

ARM CYLINDER

BUCKET CYLINDER

120099CM07

· Tightening torque

Item	Size	kgf · m	lbf · ft
1	M12×1.75	9.4±1.0	68.0±7.2
2	M14×2.0	15±1.5	109±10.8
3	M16×2.0	23±2.3	166±16.6
4	M30×3.5	157±16	1136±116

Item	Size	kgf · m	lbf · ft
5	M33×3.5	215±21.5	1555±156
6	M22×2.5	4.1	29.6
7	M27×3.0	5.1	36.9