

## SECTION 3 HYDRAULIC SYSTEM

Group 1 Hydraulic Circuit .....	3-1
Group 2 Main Circuit .....	3-2
Group 3 Pilot Circuit .....	3-5
Group 4 Single Operation .....	3-11
Group 5 Combined Operation .....	3-21

SECTION 3 HYDRAULIC SYSTEM

GROUP 1 HYDRAULIC CIRCUIT

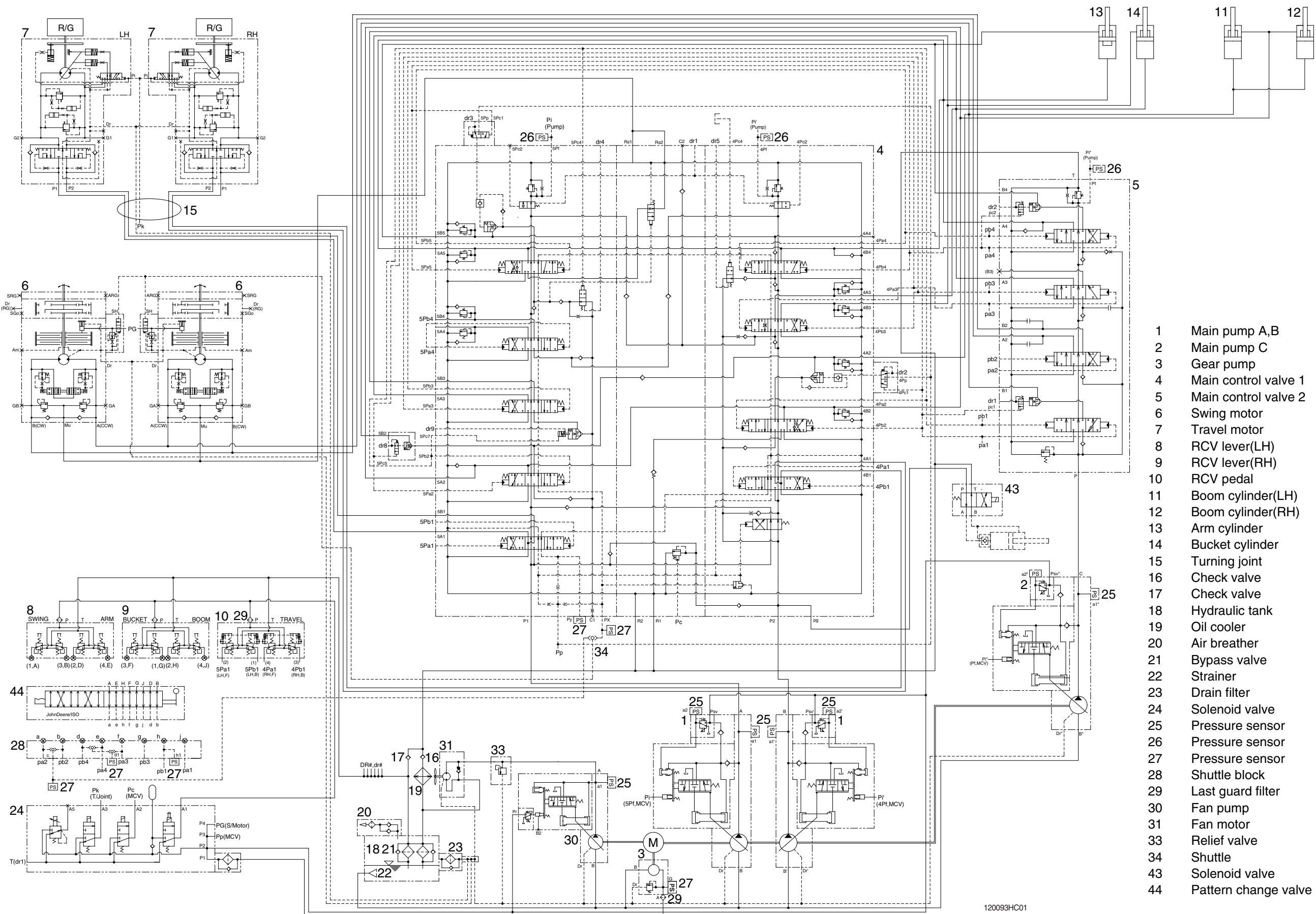

- 1 Main pump A,B
- 2 Main pump C
- 3 Gear pump
- 4 Main control valve 1
- 5 Main control valve 2
- 6 Swing motor
- 7 Travel motor
- 8 RCV lever(LH)
- 9 RCV lever(RH)
- 10 RCV pedal
- 11 Boom cylinder(LH)
- 12 Boom cylinder(RH)
- 13 Arm cylinder
- 14 Bucket cylinder
- 15 Turning joint
- 16 Check valve
- 17 Check valve
- 18 Hydraulic tank
- 19 Oil cooler
- 20 Air breather
- 21 Bypass valve
- 22 Strainer
- 23 Drain filter
- 24 Solenoid valve
- 25 Pressure sensor
- 26 Pressure sensor
- 27 Pressure sensor
- 28 Shuttle block
- 29 Last guard filter
- 30 Fan pump
- 31 Fan motor
- 33 Relief valve
- 34 Shuttle
- 43 Solenoid valve
- 44 Pattern change valve

120093HC01